

Dealer's Manual

ROAD	MTB	Trekking
City Touring/ Comfort Bike	URBAN SPORT	E-BIKE

SHIMANO STEPS

SHIMANO STEPS Special Battery and Parts

BT-E6000
BT-E6001
BT-E6010
BT-E8010
BT-E8014
BT-E8016
BT-E8020
BT-E8035
BT-E8035-L
BT-E8036
EC-E6000
EC-E6002
EC-E8004
BM-E6000
BM-E6010
BM-E8010
BM-E8016
BM-E8020
BM-E8030-A
BM-E8030-B
BM-E8031-A
BM-E8031-B

EW-SW100
EW-SW300
EW-CP100

Contents

Contents	2
IMPORTANT NOTICE	3
TO ENSURE SAFETY	4
List of tools to be used.....	13
Installation/removal	15
Wiring example.....	15
Electric wires.....	16
• Supported products.....	16
• Conversion adapter	17
• Connecting / disconnecting the electric wire	17
Installing the battery mount.....	22
• Rear carrier mount type.....	22
• External mount type	25
• Integrated mount type	35
Installing the satellite charging port	48
• EW-CP100.....	48
Installing the satellite system ON/OFF switch	49
• EW-SW100 / EW-SW300.....	49
Maintenance.....	51
Replacing the double latch plate	51
Replacing the spring unit	51
Replacing the charging port cap.....	52
Charging of the satellite system ON/OFF switch.....	52
Troubleshooting	56



IMPORTANT NOTICE

- **This dealer's manual is intended primarily for use by professional bicycle mechanics.** Users who are not professionally trained for bicycle assembly should not attempt to install the components themselves using the dealer's manuals. If any part of the information on the manual is unclear to you, do not proceed with the installation. Instead, contact your place of purchase or a distributor for assistance.
- Make sure to read all manuals included with the product.
- Do not disassemble or modify the product other than as stated in the information contained in this dealer's manual.
- All manuals and technical documents are accessible online at <https://si.shimano.com>.
- For consumers who do not have easy access to the internet, please contact a SHIMANO distributor or any of the SHIMANO offices to obtain a hardcopy of the User's Manual.
- Please observe the appropriate rules and regulations of the country, state or region in which you conduct your business as a dealer.

For safety, be sure to read this dealer's manual thoroughly before use, and follow it for correct use.

The following instructions must be observed at all times in order to prevent personal injury and physical damage to equipment and surroundings.

The instructions are classified according to the degree of danger or damage which may occur if the product is used incorrectly.

 DANGER	Failure to follow the instructions will result in death or serious injury.
 WARNING	Failure to follow the instructions could result in death or serious injury.
 CAUTION	Failure to follow the instructions could cause personal injury or physical damage to equipment and surroundings.

TO ENSURE SAFETY

DANGER

Be sure to also inform users of the following:

■ Handling the battery:

- Use the specified battery charger for charging and observe the specified charging conditions. Doing otherwise may cause overheating, bursting, or ignition.
- Do not leave the battery near sources of heat such as heaters. Doing so may cause bursting or ignition.
- Do not heat the battery or throw it into a fire. Doing so may cause bursting or ignition.
- Do not deform, modify, disassemble, or apply solder directly to the battery. Doing so may cause leakage, overheating, bursting, or ignition.
- Do not connect the terminals with metallic objects. Doing so may cause them to short circuit or overheat, and result in burns or injury.
- Do not carry or store the battery together with metallic objects such as necklaces or hairpins. Doing so may cause them to short circuit or overheat, and result in burns or injury.
- Do not place the battery into fresh water or sea water, and do not allow the battery terminals to get wet. Doing otherwise may cause it to overheat, burst, or ignite.
- Do not throw or subject the battery to strong shock. Doing so may cause overheating, bursting, or ignition.

■ Handling the battery charger:

- Do not allow the battery charger to get wet. If it is wet or water is allowed inside, it could cause a fire, ignition, overheating, or electric shock.
- Do not use it while it is wet, and do not touch or hold it with wet hands. An electric shock may occur.
- Do not use the battery charger when it is covered with a cloth or other material. Doing otherwise may cause the heat to build up and the case may become deformed, or fire, ignition, or overheating may occur.
- Do not disassemble or modify the battery charger. If this is not observed, electric shocks or injury may occur.
- Use the battery charger at the specified power supply voltage only. If a power supply voltage other than that specified is used, fire, destruction, smoke, overheating, electric shocks or burns may occur.

- Use the specified battery and battery charger combination for charging and observe the specified charging conditions. Doing otherwise may cause overheating, bursting, or ignition.

WARNING

- **Be sure to follow the instructions provided in the manuals when installing the product.** Only use SHIMANO genuine parts. If a component or replacement part is incorrectly assembled or adjusted, it can lead to component failure and cause the rider to lose control and crash.
-  Wear approved eye protection while performing maintenance tasks such as replacing components.
- For information on products not explained in this manual, refer to the manuals provided with each product.

Be sure to also inform users of the following:

- Do not insert or remove the plug while it is wet. Doing so may result in electric shock. If the inside of the plug is wet, dry it thoroughly before inserting it.
- Do not recharge the battery in wet or very humid places, or outdoors. A fire, ignition, overheating, or electric shock may occur.
- If the battery does not become fully charged even two hours after the designated charging time, immediately unplug the battery from the electrical outlet and contact the place of purchase. Doing otherwise may cause overheating, bursting, or ignition. Refer to the user's manual of the battery charger or the "SHIMANO STEPS special battery and parts user's manual (<https://si.shimano.com/um/7GP0A/>)" for information on the designated charging time of the battery.

■ Handling the battery:

- If any liquid leaking from the battery gets into your eyes, immediately wash the affected area thoroughly with clean water such as tap water without rubbing your eyes, and seek medical attention immediately. If this is not done, the battery liquid may damage your eyes.
- Do not use it outside of the operating temperature range of the battery. If the battery is used or stored in temperatures which are outside these ranges, fire, injury or problems with operation may occur.
 1. During discharge: -10°C - 50°C
 2. During charging: 0°C - 40°C
- Do not use the battery if it has any noticeable scratches or other external damage. If this is not observed, bursting, overheating or problems with operation may occur.

- Do not use the battery if leakages, discoloration, deformation, or any other abnormalities occur. If this is not observed, bursting, overheating or problems with operation may occur.

■ Handling the battery charger:

- Be sure to hold the power plug when connecting or disconnecting from the electrical outlet. Failure to do so may cause a fire or electric shock. If the following symptoms are observed, stop using the device and contact the place of purchase. A fire or electric shock may be caused.
 - * If heat or acrid-smelling smoke is coming out from the power plug.
 - * There may be a bad connection inside the power plug.
- Do not touch the metallic parts of the device or the power plug on the AC adapter or other parts if there is a lightning storm. If lightning strikes, electric shocks may occur.
- Do not overload the electrical outlet with appliances beyond its rated capacity, and use only a 100 - 240 V AC electrical outlet. If the electrical outlet is overloaded by connecting too many appliances using adapters, overheating resulting in fire may occur.
- Do not damage the power cord or power plug. (Do not damage, process, forcibly bend, twist or pull them, bring them near hot objects, place heavy objects on them or bundle them tightly together.)
If they are used while damaged, fire, electric shocks or short-circuits may occur.
- Do not use the battery charger with commercially-available electrical transformers designed for overseas use (travel converters). They may damage the battery charger.
- Always be sure to insert the power plug as far as it will go. If this is not observed, fire may occur.
- When charging the battery while it is installed on the bicycle, do not move the bicycle. The battery charger's power plug may come loose and not be fully inserted into the electrical outlet, resulting in a risk of fire.

■ For installation to the bicycle, and maintenance:

- Be sure to remove the battery and charging cable before wiring or attaching parts to the bicycle. Otherwise, an electric shock may result.

CAUTION

Be sure to also inform users of the following:

■ Handling the battery:

- Do not leave the battery in a place exposed to direct sunlight, inside a vehicle on a hot day, or other hot places. This may result in battery leakage.

- If any leaked fluid gets on your skin or clothes, wash it off immediately with clean water. The leaked fluid may damage your skin.
- Keep away from children.
- Handle components with both hands. Failure to do so may cause the components to fall and break or cause injury.
- If an error occurs during the battery discharge or charge operation, immediately stop using it and check the user's manual. If you are not sure, consult the place of purchase or a distributor.
- Avoid touching the battery for an extended period of time when it is at a high temperature. Doing so may cause a low-temperature burn. Riding with a high level of assistance on hot days or charging the battery in direct sunlight may cause the surface temperature of the battery to exceed 60°C (BT-E8036).

■ Handling the battery charger:

- When performing cleaning, disconnect the power plug from the electrical outlet and the charging plug from the battery. If this is not observed an electric shock may occur.
- Do not let the battery touch the same area of skin for an extended period of time while it is charging. The temperature of components may reach 40 to 70°C, which can cause low-temperature burns.
- Periodically check the battery charger and adapter, particularly the cord, plug, and case, for any damage. If the battery charger or adapter is broken, do not use it until it has been repaired by the place of purchase or a distributor.
- Use the product according to the directions for use or those of a safety supervisor. Do not allow anyone (including children) with reduced physical, sensual, or mental capacity, or those without experience or knowledge, to use the product. Do not allow children to play near the product.

NOTICE

Be sure to also inform users of the following:

- Be sure to attach dummy plugs to any unused ports.
- For installation and adjustment of the product, consult the place of purchase.
- The components are designed to be fully waterproofed to withstand wet weather riding conditions; however, do not deliberately place them into water.
- Handle the components carefully, and avoid subjecting them to strong shock.
- Before connecting the battery, make sure that there is no water collecting in the area where the battery will be connected (connector), and that it is not dirty.

- It is recommended to use a SHIMANO genuine battery. If using a battery from another company, be sure to read the owner's manual thoroughly prior to use.
- Some of the important information in this dealer's manual can also be found on the device labels.

Charging can be carried out at any time, regardless of the remaining battery, but please fully charge the battery in the following cases:

- The battery cannot be used at the time of purchase. Before riding, be sure to fully charge the battery.
- If the battery has become completely empty, charge it as soon as possible. If you leave the battery without charging it, the battery will deteriorate and may become unable to be used.

■ Handling the battery:

- If the screen of the cycle computer is not displayed, fully charge the battery. The battery level may affect the display.
- Press the battery power button and if the LED display does not light up, the protective circuit is operating. Connect the battery charger and charge the battery to deactivate this.
- If the battery is charged in a low-temperature environment of 5°C or lower, the traveling distance of a full charge will be shorter. Also, if the battery is used in a low-temperature environment of 5°C or lower, the battery consumption will become quicker. This is due to the characteristics of the battery, and the battery will return to normal when at a normal temperature.
- Riding with a high level of assistance in a low-temperature environment when the battery level is low may cause the battery level to drop to 0%, due to the characteristics of the battery. Charge it before use.

■ Handling the battery charger:

- The battery can be charged at temperatures between 0°C - 40°C. The battery charger will not operate at temperatures outside the range. It will display an error. (The battery charger LED lamp flashes.)
- Do not use in environments with high humidity. (EC-E8004)
- Do not use outdoors or in environments with high humidity. (Battery charger other than the EC-E8004)
- Charge the battery in a location not exposed to rain or wind. (EC-E8004)

- Charge the battery indoors to avoid exposure to rain or wind. (Battery charger other than the EC-E8004)
- Do not place the battery charger on dusty floors when using it.
- Place the battery charger on a stable surface such as a table when using it.
- Do not place any objects on top of the battery charger or its cable. Also, do not cover them with the cover.
- Do not bundle the cables.
- Do not hold the battery charger by the cables when carrying it.
- Do not apply excessive tension to the cable and charging plug.
- In order to prevent the cable from being damaged, avoid wrapping it around the main body during storage.
- Do not wash the battery charger or wipe it using detergents.
- Do not allow children to play near the product.
- When charging with the battery installed to a bicycle, take care that your legs, etc. do not get caught in the battery charger cord. Doing so may cause injury or cause the bicycle to fall over and break the components.
- When charging the battery while it is mounted on the bicycle, be careful of the following:
 - Before charging, check that there is no water on the charging port of the charging plug.
 - Check that the battery mount is locked before charging.
 - Do not remove the battery from the battery mount while charging.
 - Do not ride with the battery charger mounted.
 - Close the cap on the charging port when not charging.
 - Fix the bicycle in place when charging, so that it does not tip over.
- Make sure to close the charging port cap after charging is complete. If foreign material such as dirt or dust is adhering to the charging port, it may not be possible to insert the charging plug.
- Using the battery outside the operating temperature range may cause problems with operation or performance degradation.
- The charging time is longer when the battery temperature is high.

■ Care and maintenance:

- The number written on the key of the battery mount is necessary when purchasing a spare key. Store it carefully.
- Do not use thinner or other solvents to clean any of the components. Such substances may damage the surface.
- When there is dirt on the terminals of the battery mount and battery charger, remove the battery, remove the power plug from the electrical outlet, then clean them with a clean rag or cotton bud dampened with ethanol, etc. If you repeatedly install and remove the battery while they are still dirty, it may cause wear on the terminals and make them unable to be used.

Terminal example

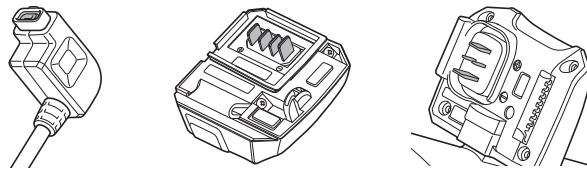

- Keep the surface where the battery contacts the battery mount clean. If the battery is connected with foreign material such as dirt or dust attached, the battery may become unable to be removed.



- Use a damp, well wrung out cloth, when cleaning the battery and plastic cover.
- For any questions regarding methods of installation and maintenance, please contact your place of purchase.
- Contact the place of purchase for updates of the component software. The most up-to-date information is available on the SHIMANO website.
- Products are not guaranteed against natural wear and deterioration from normal use and aging.
- For maximum performance we highly recommend SHIMANO lubricants and maintenance products.

The actual product may differ from the illustration because this manual is intended mainly to explain the procedures for using the product.

Booklet structure

■ User's manual

SHIMANO STEPS series user's manuals are split among several booklets, as described below.

The latest manuals are available on our website (<https://si.shimano.com>).

Name	Details
SHIMANO STEPS User's Manual	This is the basic manual for the SHIMANO STEPS series. It contains the following content: <ul style="list-style-type: none"> • SHIMANO STEPS quick guide • Basic operations when riding • How to operate assist bicycles that use flat handlebars, such as city, trekking, or MTB type bicycles • General troubleshooting
SHIMANO STEPS User's Manual for Drop Handlebar Bicycles (separate booklet)	This booklet describes how to operate assist bicycles that use a drop handlebar and are controlled using dual control levers. This should be read along with the SHIMANO STEPS User's Manual.
SHIMANO STEPS Special Battery and Parts User's Manual (separate booklet)	It contains the following content: <ul style="list-style-type: none"> • How to charge and handle the SHIMANO STEPS special battery • How to attach and remove the SHIMANO STEPS special battery to the bicycle • How to use the satellite system ON/OFF switch and satellite charging port • How to read the battery LEDs when charging or during an error, and how to handle errors
SHIMANO STEPS Cycle Computer User's Manual	It contains the following content: <ul style="list-style-type: none"> • Method for configuring settings via the main body buttons and switch unit • Wireless communication method • Problems and errors/warnings and remedies
Switch Unit User's Manual	This is the assist switch and shifting switch user's manual. It describes switch unit handling and operations only.

■ Dealer's manual















SHIMANO STEPS series dealer's manuals are split among several booklets, as described below.













The latest manuals are available on our website (<https://si.shimano.com>).

Name	Details
SHIMANO STEPS Dealer's Manual	<p>This is the basic manual for the SHIMANO STEPS series.</p> <ul style="list-style-type: none"> • Overall wiring diagram • Overall flow of operations for installing the SHIMANO STEPS components to an assist bicycle • Installation/removal and maintenance of the drive unit area • Installation/removal of the speed sensor
SHIMANO STEPS Dealer's Manual for Drop Handlebar Bicycles (separate booklet)	<p>It specializes in the following information regarding assist bicycles that use a drop handlebar and are controlled using dual control levers. This should be read along with the SHIMANO STEPS Dealer's Manual.</p> <ul style="list-style-type: none"> • Overall wiring diagram • Cautions to follow when installing the drive unit
SHIMANO STEPS Special Battery and Parts Dealer's Manual (this document)	<p>It contains the following content:</p> <ul style="list-style-type: none"> • How to install the battery mount • How to install the satellite system ON/OFF switch and satellite charging port
SHIMANO STEPS Cycle Computer and Switch Unit Parts Dealer's Manual	<p>It contains the following content:</p> <ul style="list-style-type: none"> • Installation and maintenance of the SHIMANO STEPS special cycle computer, special junction [A] and switch unit • How to connect to the PC version of E-TUBE PROJECT
SHIMANO STEPS Chain Device Dealer's Manual	<p>This manual describes the installation and maintenance of the SHIMANO STEPS special chain device.</p>

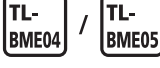
List of tools to be used

The following tools are needed for installation/removal, adjustment, and maintenance purposes.

Component	Location used/screw type	Tool	
Electric wire (EW-SD50)	Plug		TL-EW02
Electric wire (EW-SD300)	Plug		TL-EW300
Battery mount (BM-E6000)	Key unit		Cross head screwdriver [#2]
			Slotted screwdriver (6.5 mm)
	Lower case		Cross head screwdriver [#2]
	Upper case		Hexalobular [#10]
Battery mount (BM-E6010)	Lower case Key unit		3 mm hexagon wrench
	Key unit (adjust installation location)		TL-BME01
	Key unit cover Upper case		Cross head screwdriver [#1]
Battery mount (BM-E8010 / BM-E8016)	Lower case		3 mm hexagon wrench
			8 mm spanner
	Key unit		3 mm hexagon wrench
	Key unit (adjust installation location)		TL-BME02
	Key unit cover Upper case		2.5 mm hexagon wrench

Component	Location used/screw type	Tool	
Battery mount (BM-E8020)	Lower case Key unit		5 mm hexagon wrench
	Key unit (adjust installation location)		TL-BME03
	Upper case / key unit cover		Cross head screwdriver [#2]
	Key cylinder		2 mm hexagon wrench
Battery mount (BM-E8030 / BM-E8031)	Upper bracket		4 mm hexagon wrench
	Spring unit		1.5 mm hexagon wrench
	Latch base / key cylinder / lower bracket / connector unit		3 mm hexagon wrench
			TL-BME04 / TL-BME05
	Unlock pin unit		2.5 mm hexagon wrench
Satellite charging port (EW-CP100)	Mounting screw		2 mm hexagon wrench
Satellite system ON/OFF switch (EW-SW100 / EW-SW300)	Mounting screw		2 mm hexagon wrench
Maintenance (BM-E8030 / BM-E8031)	Double latch plate		2 mm hexagon wrench
	Spring unit		1.5 mm hexagon wrench
Maintenance (charging of the satellite system ON/OFF switch)	Drive unit cover		Cross head screwdriver [#2]

Installation/removal

Wiring example

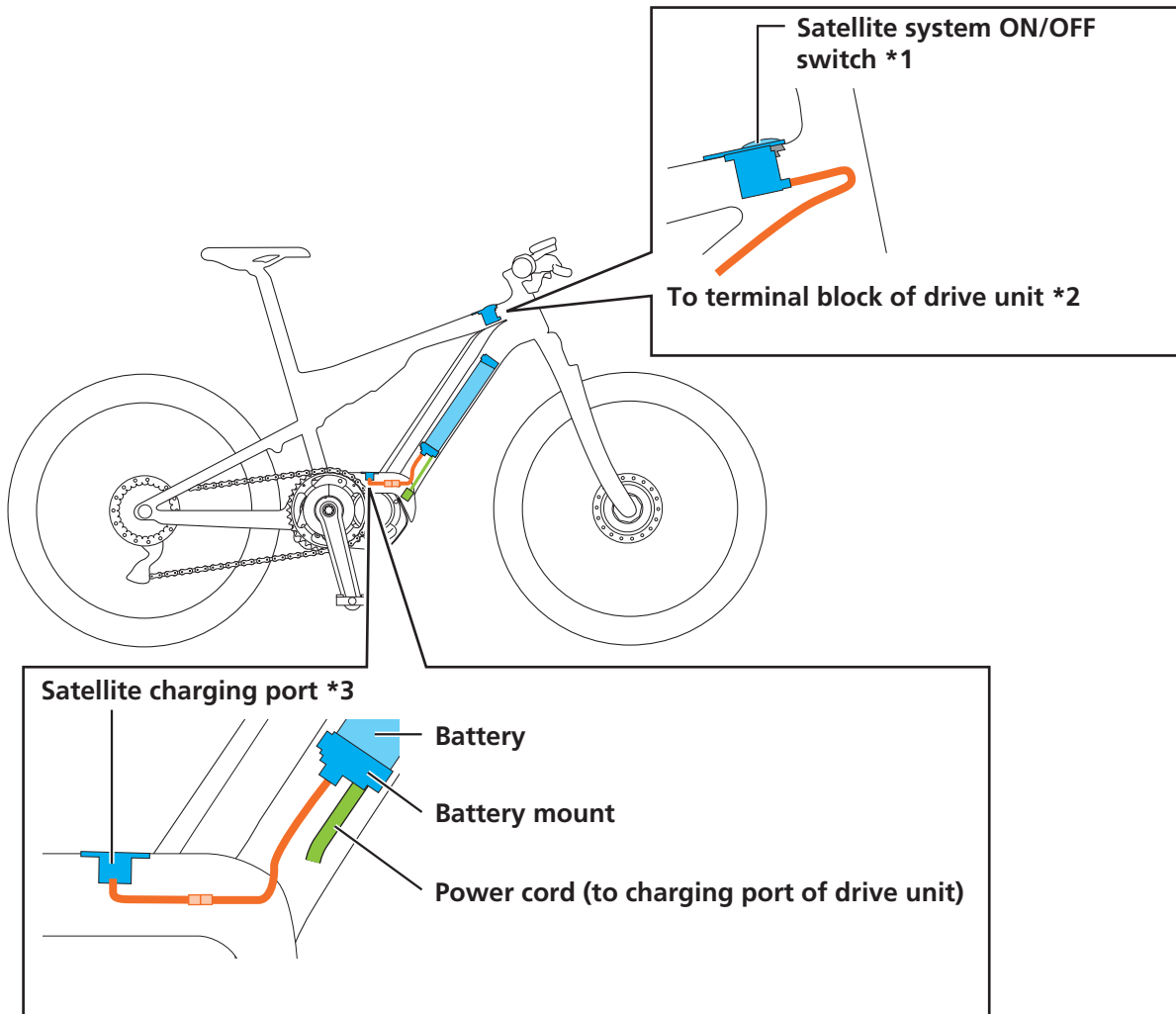

*1 There are two types of satellite system ON/OFF switches, one using EW-SD50 type electric wire and the other using EW-SD300 type electric wire. (Refer to “Electric wires.”)

*2 Connect the electric wire of the satellite system ON/OFF switch to the terminal block of the drive unit or to the drive unit via junction [B].

*3 Take care to ensure that the satellite charging port is compatible with the battery mount. For details, refer to the compatibility information at <https://productinfo.shimano.com>.

NOTICE

- The maximum electric wire length between components is 1,600 mm. Ensure that the total length is 1,600 mm or less when connecting via a junction [B] or conversion adapter.

Electric wires

There are two types of electric wire: the EW-SD300 and the EW-SD50. The supported electric wire differs according to the model. Check the component specifications on the SHIMANO product website in advance (<https://productinfo.shimano.com/>).

Supported products

The following products support each type of electric wire.

Product name	Intended purpose	EW-SD300 type	EW-SD50 type
SHIMANO original tool	Connecting / disconnecting the electric wire	TL-EW300	TL-EW02
Dummy plug	Blocking empty ports	Y7HE30000	Y6VE15000
Cord clip	Binding the wiring and the brake outer casing / brake hose together	EW-CL300-S (for shift outer casing) EW-CL300-M (for brake outer casing and brake hose)	Y70H98040
Cord cover	Supporting / protecting the electric wire (external wiring)	EW-CC300	SM-EWC2
Grommets	Installing to the wire insertion hole of a frame that supports internal wiring	EW-GM300-S EW-GM300-M	SM-GM01 SM-GM02
Cord band	Supporting the electric wire (flat handlebar external wiring)	EW-CB300-S EW-CB300-M EW-CB300-L	SM-EWE1
Junction [A] (for DI2)	Gathering the wiring around the cockpit. Also has functions for changing the shift mode, etc.	-	EW-RS910 SM-EW90-A SM-EW90-B
Junction [B]	Branching / gathering the wiring inside and outside the frame	EW-JC304 EW-JC302	SM-JC41 SM-JC40 EW-JC200 EW-JC130
Conversion adapter	Refer to "Conversion adapter."	EW-AD305	EW-AD305

NOTICE

- The SHIMANO original tool used for installation/removal and the accessories used for wiring differ for the EW-SD300 and EW-SD50. Be sure to use a compatible product.
- EW-CL300-S is marked with a groove in order to differentiate it from EW-CL300-M.

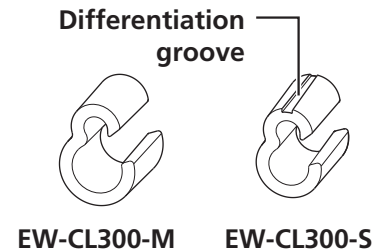
**Conversion adapter**

A conversion adapter (EW-AD305) is required to connect the EW-SD50 to a component with an E-TUBE port for the EW-SD300.

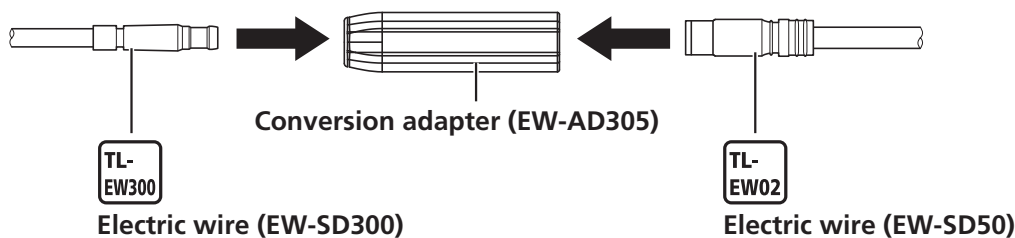
**Connecting / disconnecting the electric wire**

Be sure to use the SHIMANO original tool to remove and insert electric wires.

NOTICE

- When connecting and disconnecting electric wires, do not forcibly bend the plug part. It may result in a poor connection.

▶ Connecting the electric wire (EW-SD300)

Connect the electric wire to the E-TUBE port.

1. Set the plug of the electric wire to the TL-EW300.

If there is an alignment tab on the plug of the electric wire, check the shape of the E-TUBE port you are trying to connect to, and set it aligned with the alignment tab.

Without alignment tab on plug

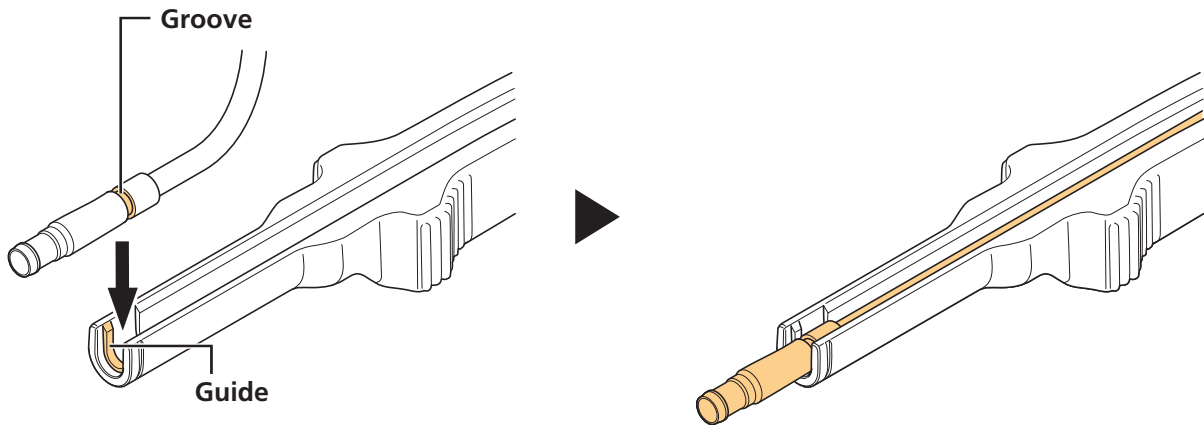

With alignment tab on plug

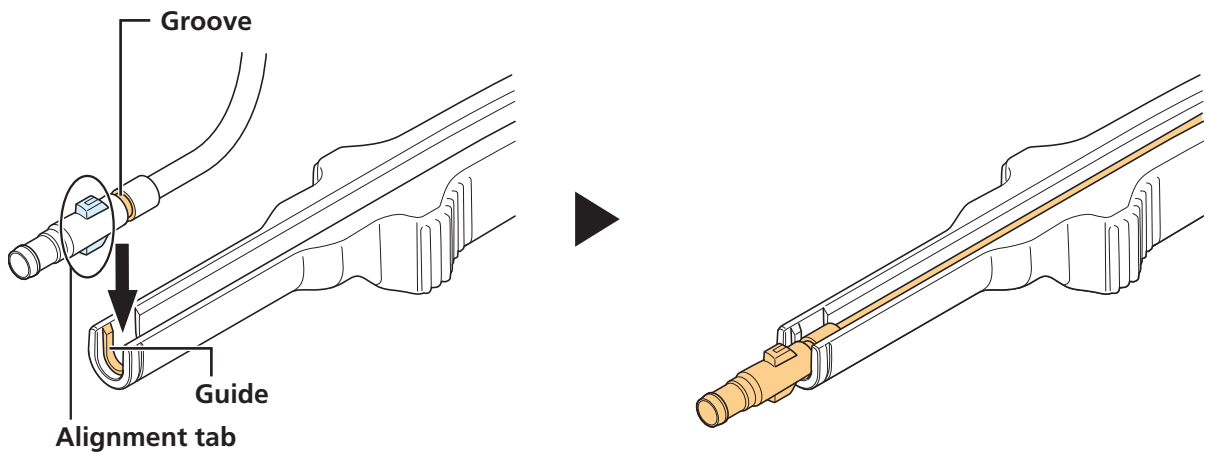

2. Insert the plug on the electric wire into the E-TUBE port.

Push it straight in until you feel it click into place.

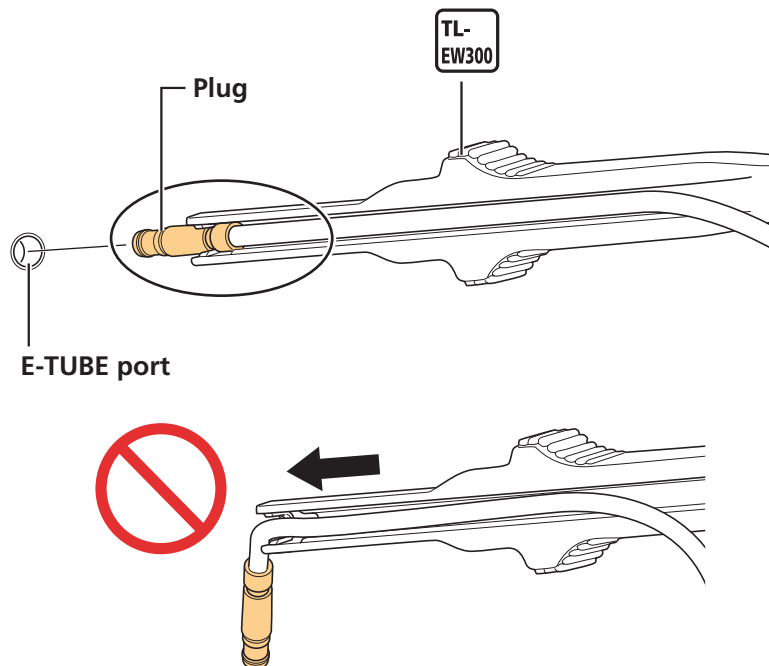

▶ Removing the electric wire (EW-SD300)

1. Remove the electric wire.

(1) Insert the TL-EW300 into the groove on the plug part of the electric wire.

(2) Disconnect the electric wire from the E-TUBE port.

* As shown in the figure, use part (A) of the TL-EW300 as a fulcrum, move the tool like a lever, then disconnect the plug part.

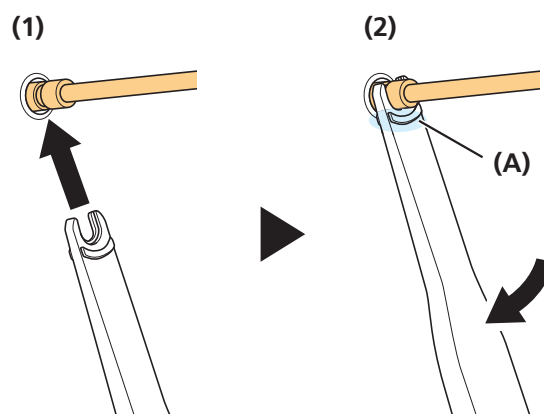

TECH TIPS

- If there is limited space to insert the tool, you can use the TL-EW300 as indicated in the figure to disconnect the electric wire.

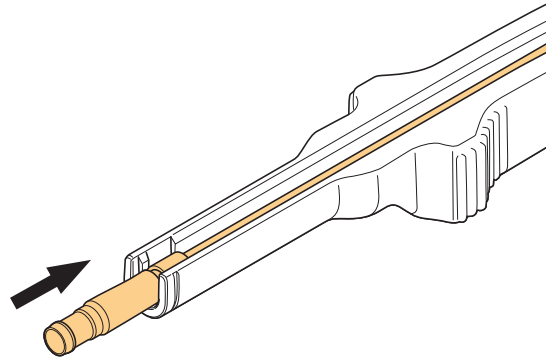
**▶ Connecting the electric wire (EW-SD50)**

Connect the electric wire to the E-TUBE port.

1. Set the plug of the electric wire to the TL-EW02.

If there is an alignment tab on the plug of the electric wire, set it aligned with the groove on the SHIMANO original tool.

Without alignment tab on plug

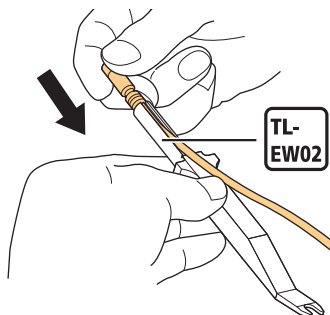

With alignment tab on plug

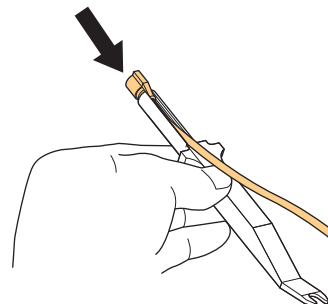

2. Insert the plug on the electric wire into the E-TUBE port.

Push it straight in until you feel it click into place.

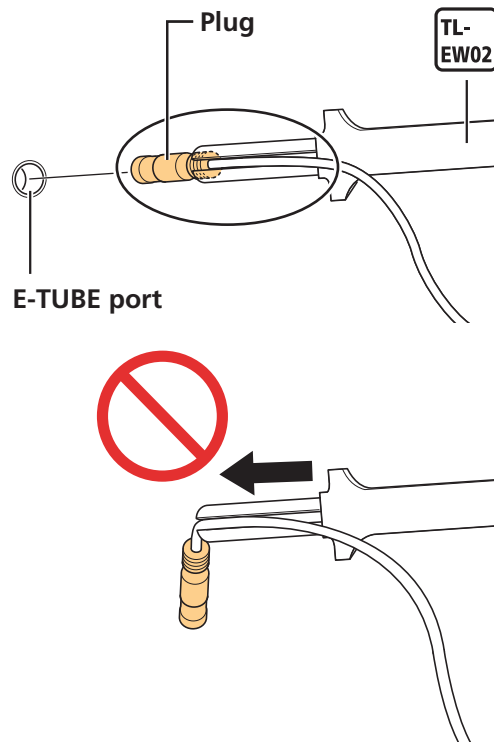

▶ Removing the electric wire (EW-SD50)

1. Remove the electric wire.

(1) Insert the TL-EW02 into the groove on the plug of the electric wire.

(2) Disconnect the electric wire from the E-TUBE port.

* As shown in the figure, use part (A) of the TL-EW02 as a fulcrum, move the tool like a lever, then disconnect the plug part. If there is limited space to insert the tool, lift the TL-EW02 straight up and disconnect the electric wire.

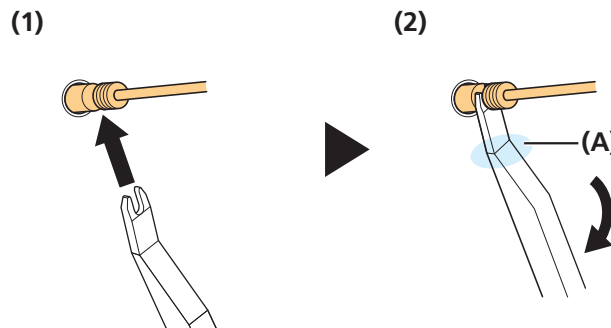

Installing the battery mount

Rear carrier mount type

▶ BM-E6000

1. Install the key unit to the lower case.

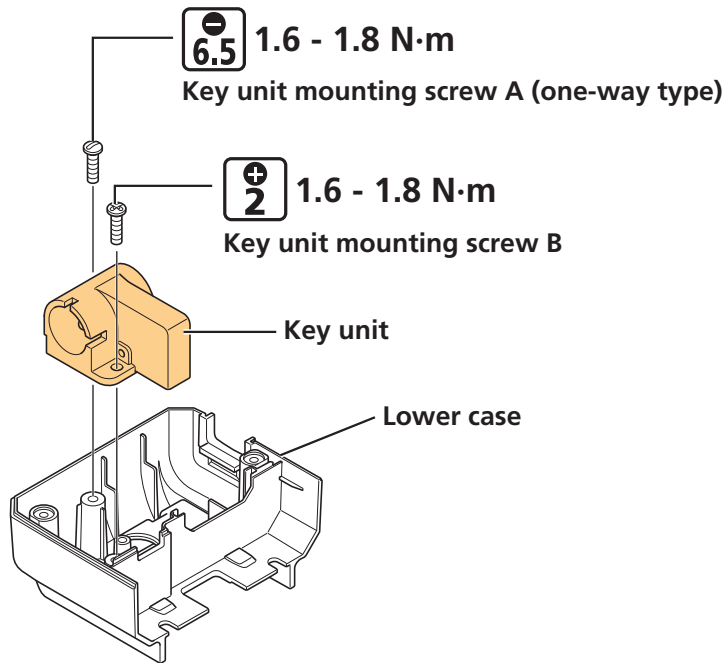

2. Set the plug unit to the lower case, and install it to the battery rail.

- (1) Set the plug unit to the lower case.
- (2) Set the battery rail to the lower case. Be careful not to pinch the power cord between the lower case and battery rail.

(3) Secure the battery rail.

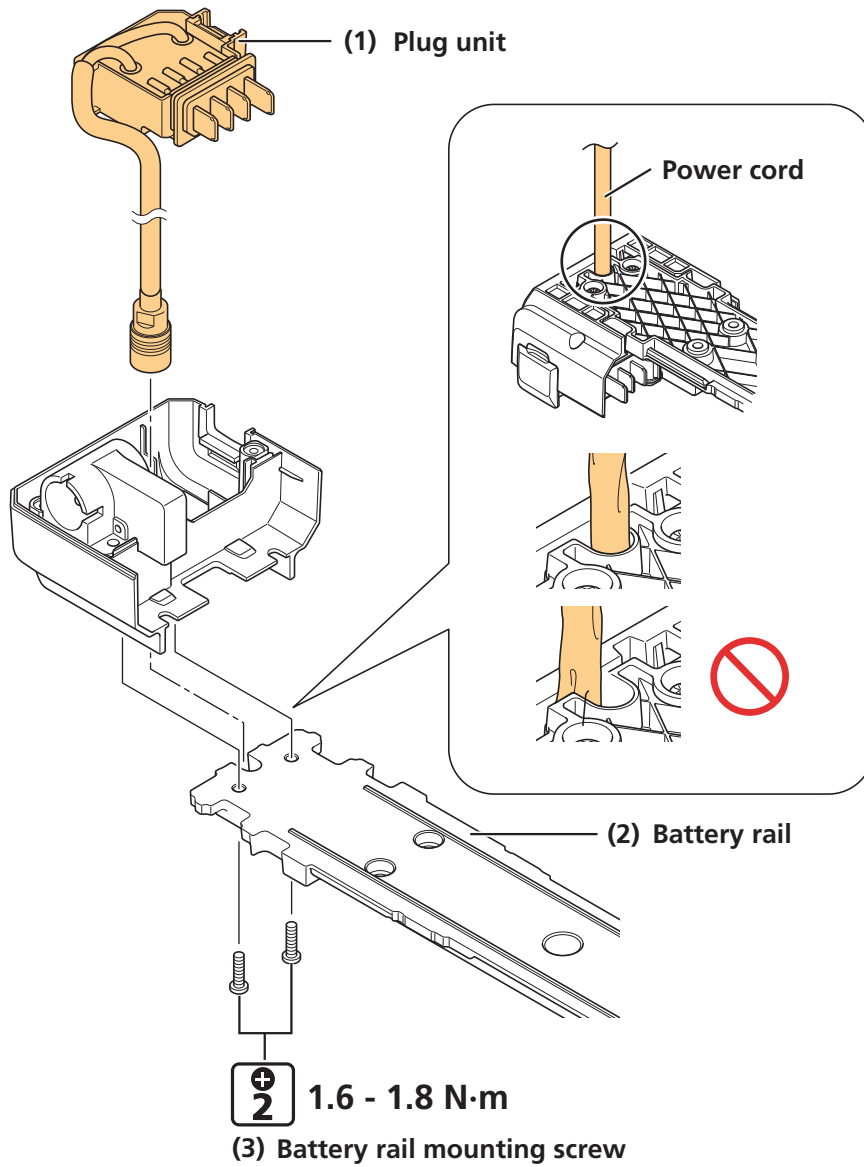

3. Install the upper case.

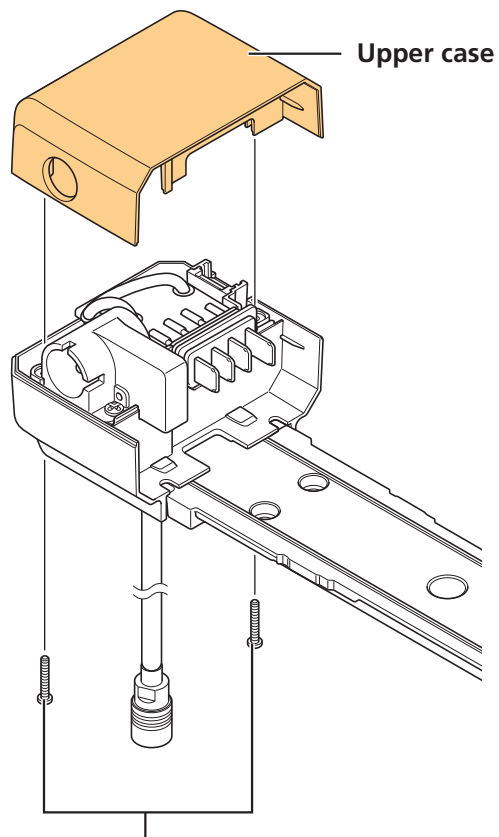

10 1.1 - 1.3 N·m
Upper case mounting screw

4. Install the battery mount to the rear carrier.

- (1) Set the battery mount aligned with the mounting hole on the rear carrier.
- (2) Secure the battery mount. Use the bicycle manufacturer's standard tightening torque.
- (3) After installing the battery mount, perform the following:

- Firmly close the charging port cap.
- Pass the power cord through the frame and leave it hanging over the drive unit installation area.

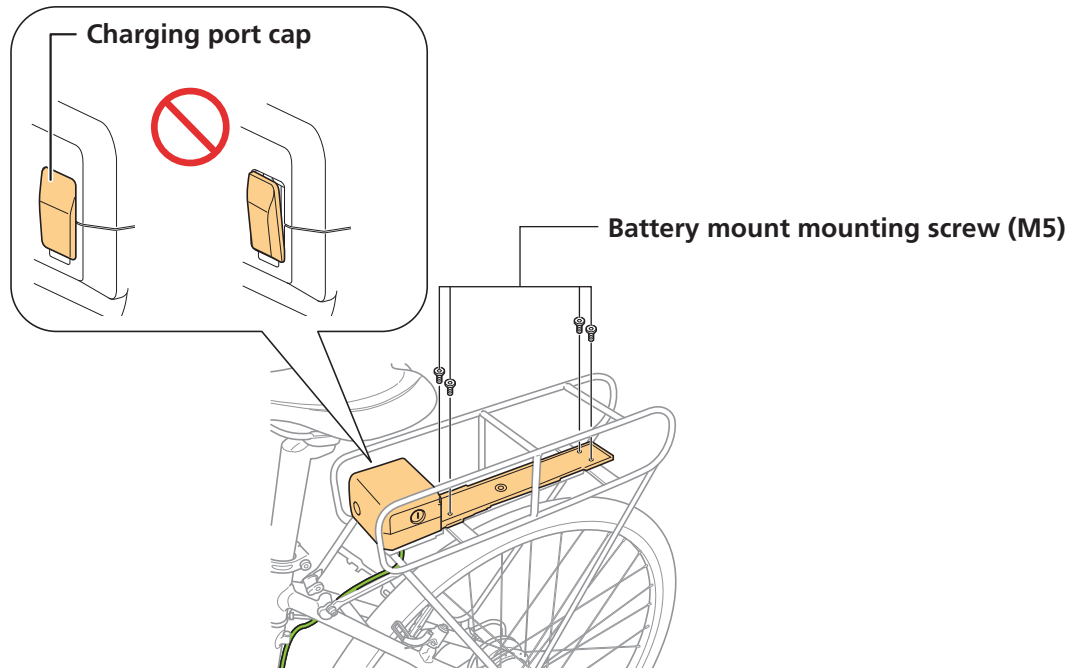

NOTICE

- Mounting screws (M5) for the battery mount are not included with SHIMANO products. Use the screws supplied by the bicycle manufacturer. Contact the bicycle manufacturer for the tightening torque.

External mount type

Depending on the frame, it may be installed at a location different from the position specified in this section.

▶ **BM-E6010**

The SHIMANO original tool TL-BME01 can be used to easily determine the installation location for the key unit.

1. Install the lower case.

Secure the lower case on the lower side of the down tube.

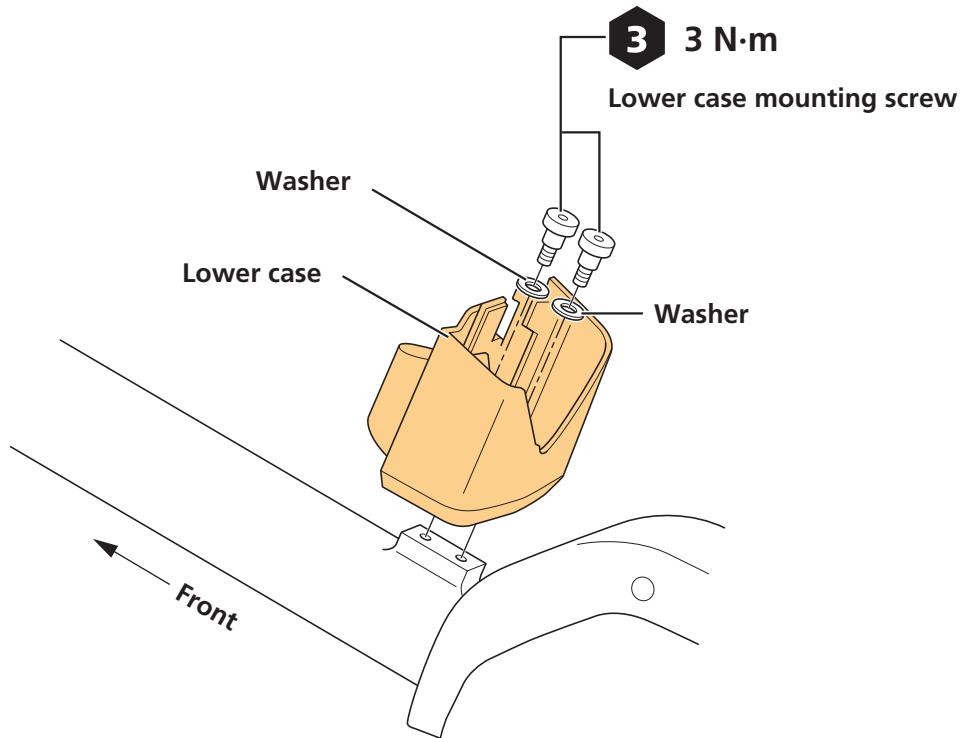

2. Temporarily install the key unit.

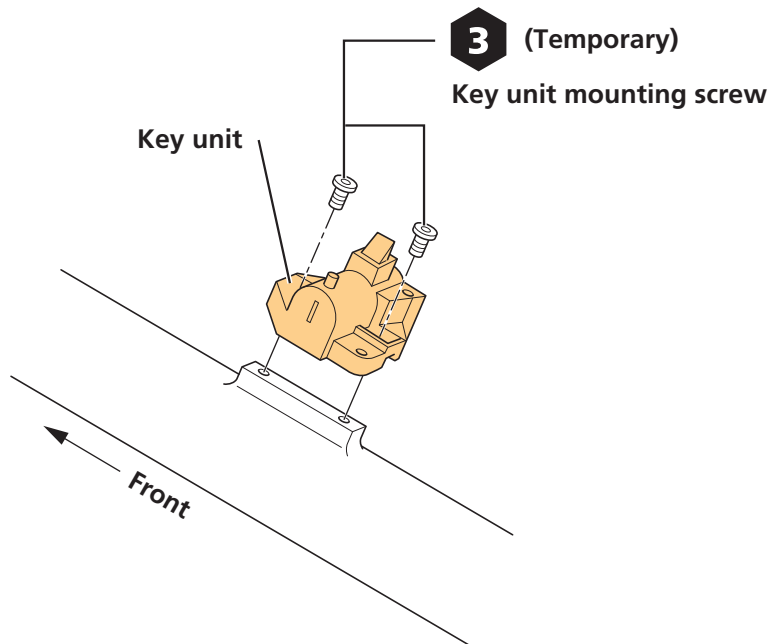

3. Use TL-BME01 to determine the location for the key unit.

(1) Align the two protrusions on the key unit with the holes in TL-BME01.

- (2) Adjust the location of the key unit so that the contact surface of TL-BME01 will be pushed against the lower case as shown in the figure.
- (3) Remove TL-BME01.

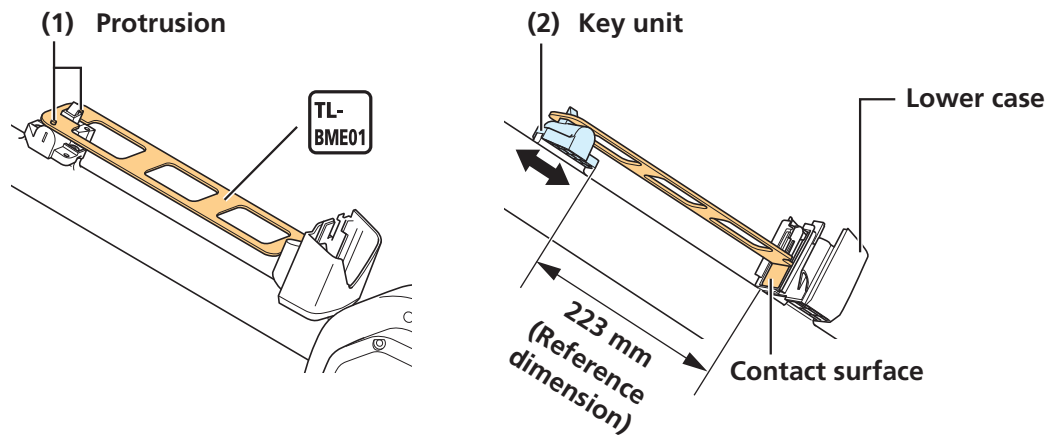

4. Secure the key unit.

- (1) Temporarily install the key unit cover, then check the following:
 - The battery can be smoothly attached and removed
 - There is no rattling in the key unit cover or battery that could result in abnormal noise when riding

(2) Remove the key unit cover, then secure the key unit.

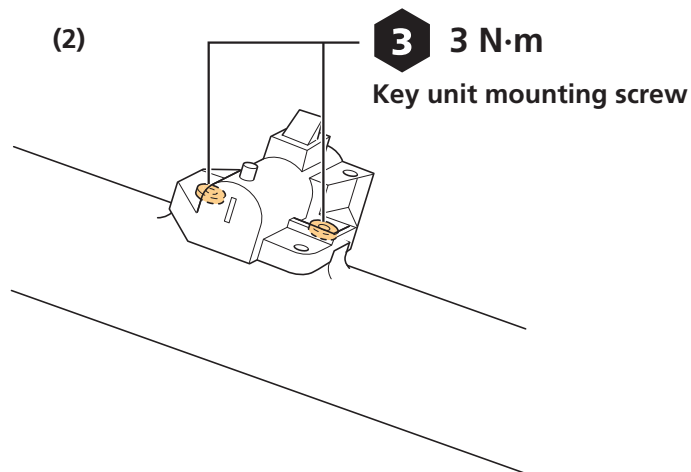
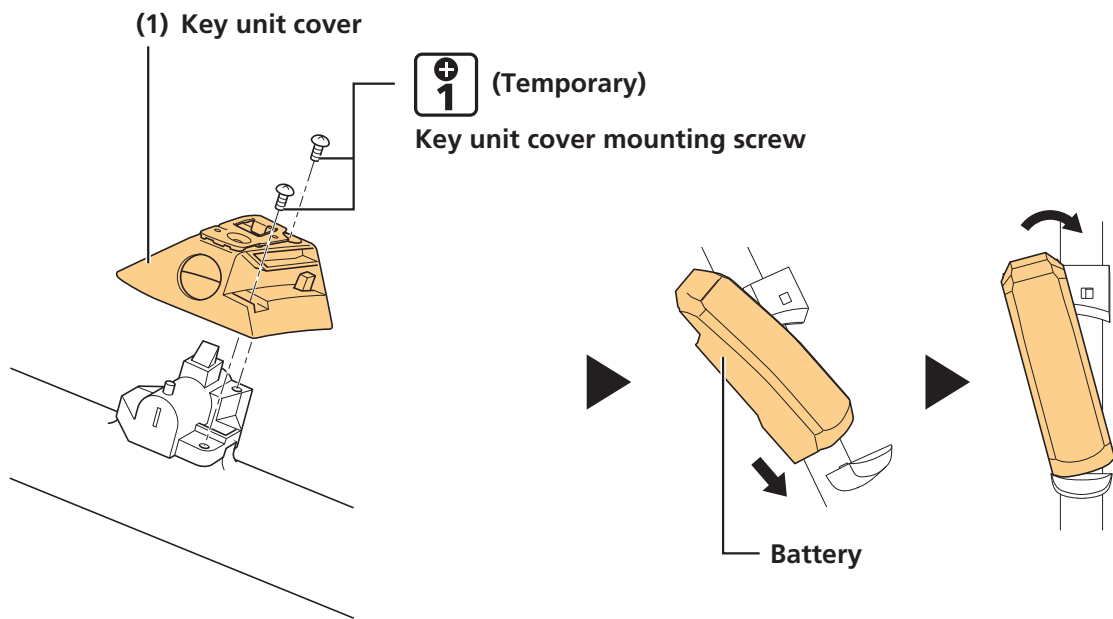

5. Install the key unit cover.

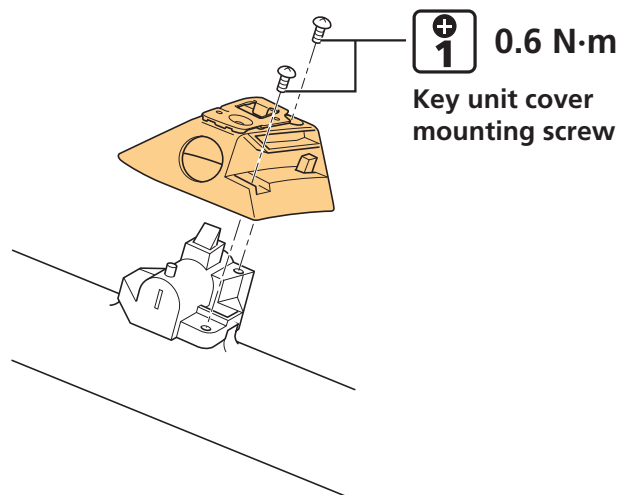

6. Install the upper case.

- (1) Open the charging port cap and pull it out fully.
- (2) Insert the plug unit into the lower case. Make sure that the plug part of the plug unit and the charging port are sufficiently exposed from the lower case.
- (3) Align the two screw holes on the upper case with the lower case, then tighten the upper case mounting screws.
- (4) After installing, perform the following:
 - Firmly close the charging port cap.
 - Pass the power cord through the frame and leave it hanging over the drive unit installation area.

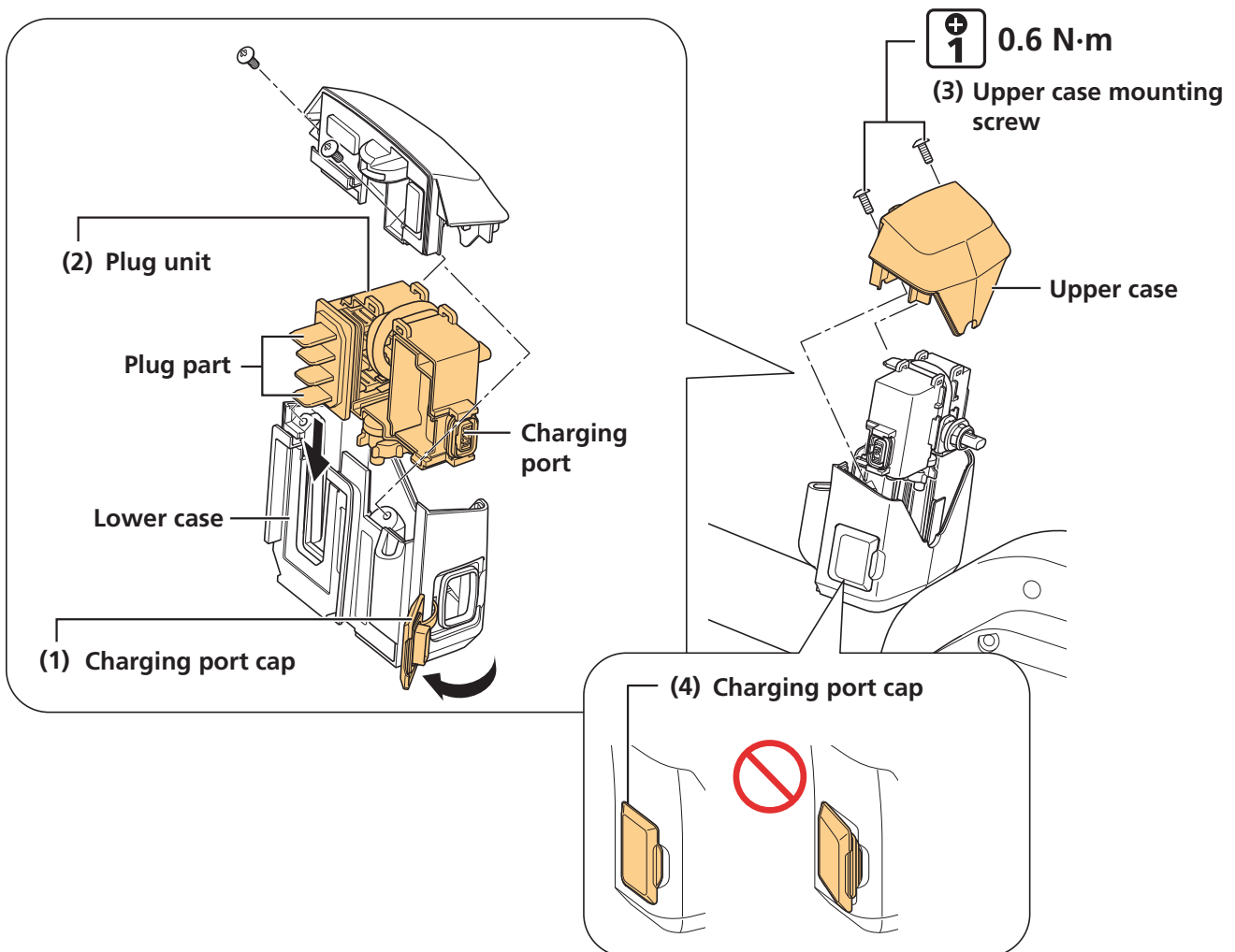

NOTICE

- Check that the power cord is not twisted between the upper case and lower case, or otherwise routed in a forced manner.

▶ BM-E8010 / BM-E8016

The SHIMANO original tool TL-BME02 can be used to easily determine the installation location for the key unit.

NOTICE

- The lower case of the BM-E8016 is composed of two parts: a metal part secured to the frame with a screw, and a plastic cover. The metal part and plastic cover may separate before the procedure in step 5. Make sure to confirm that the plastic cover has not become detached before step 5. If the plastic cover has become detached, install the upper case with the plastic cover and metal part combined in step 5. If it is difficult to install the plastic cover to the metal part secured to the frame, return to step 1 and install to the frame with the metal part and plastic cover combined.

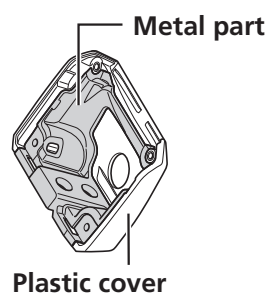

1. Install the lower case.

- (1) Set the lower case on the lower side of the down tube, then temporarily install the mounting screws.

* Temporarily install the two types of screws as shown in the figure.

- (2) Tighten lower case mounting screw A.

(3) Tighten lower case mounting screw B.

BM-E8010

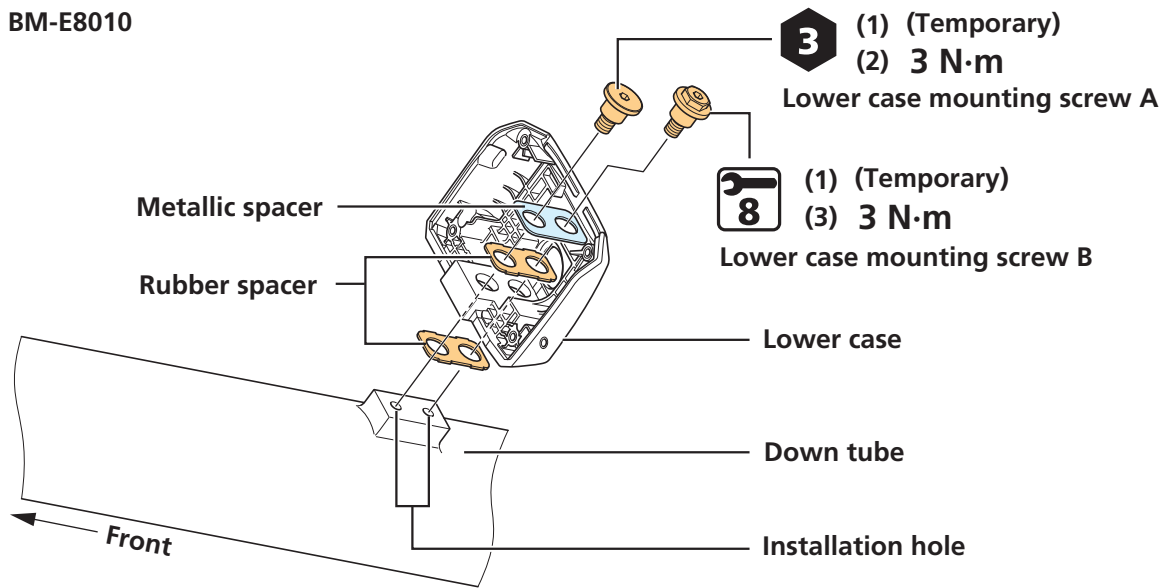

BM-E8016

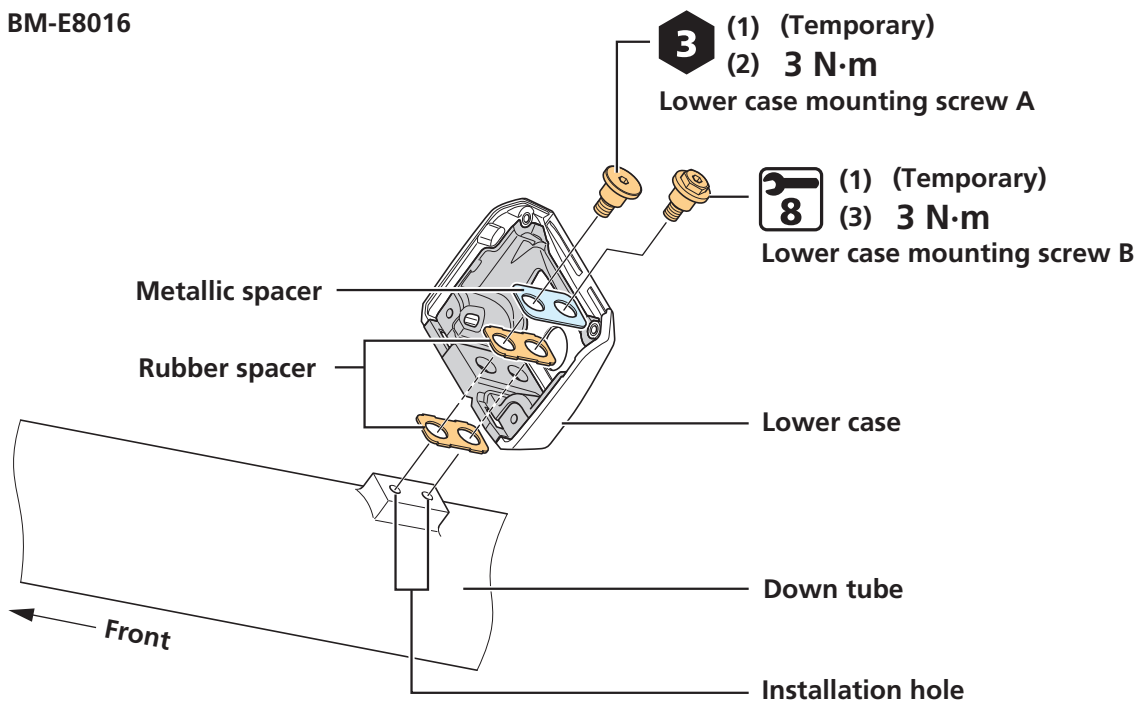

NOTICE

- The rubber spacer may be attached to the lower case.

2. Temporarily install the key unit.

Key units are not included with SHIMANO products.

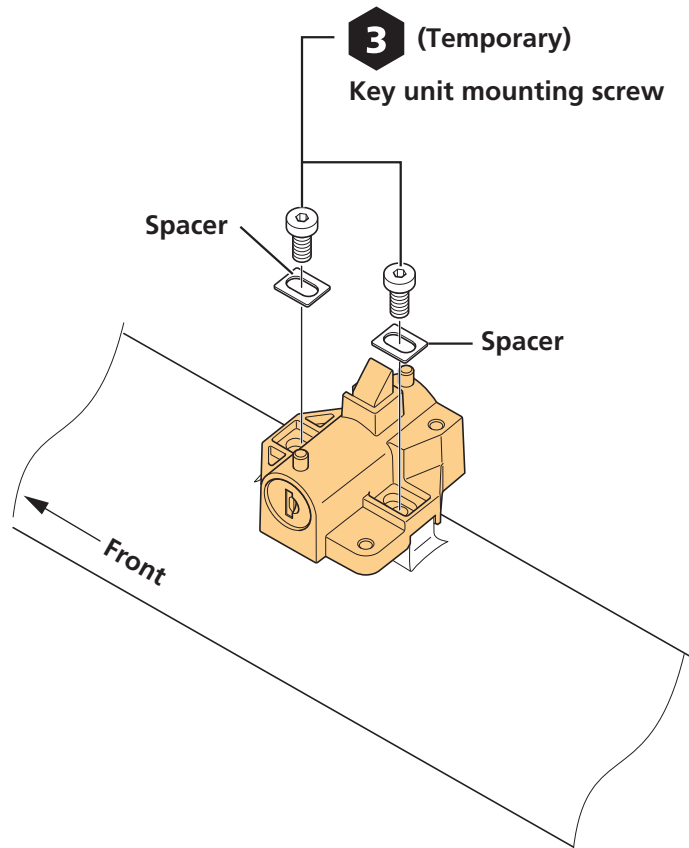

3. Use TL-BME02 to determine the location for the key unit.

- (1) Align the two protrusions on the key unit with the holes in TL-BME02.
- (2) Adjust the location of the key unit so that the contact surface of TL-BME02 will be pushed against the lower case as shown in the figure.
- (3) Tighten the key unit mounting screws.

(4) Remove TL-BME02.

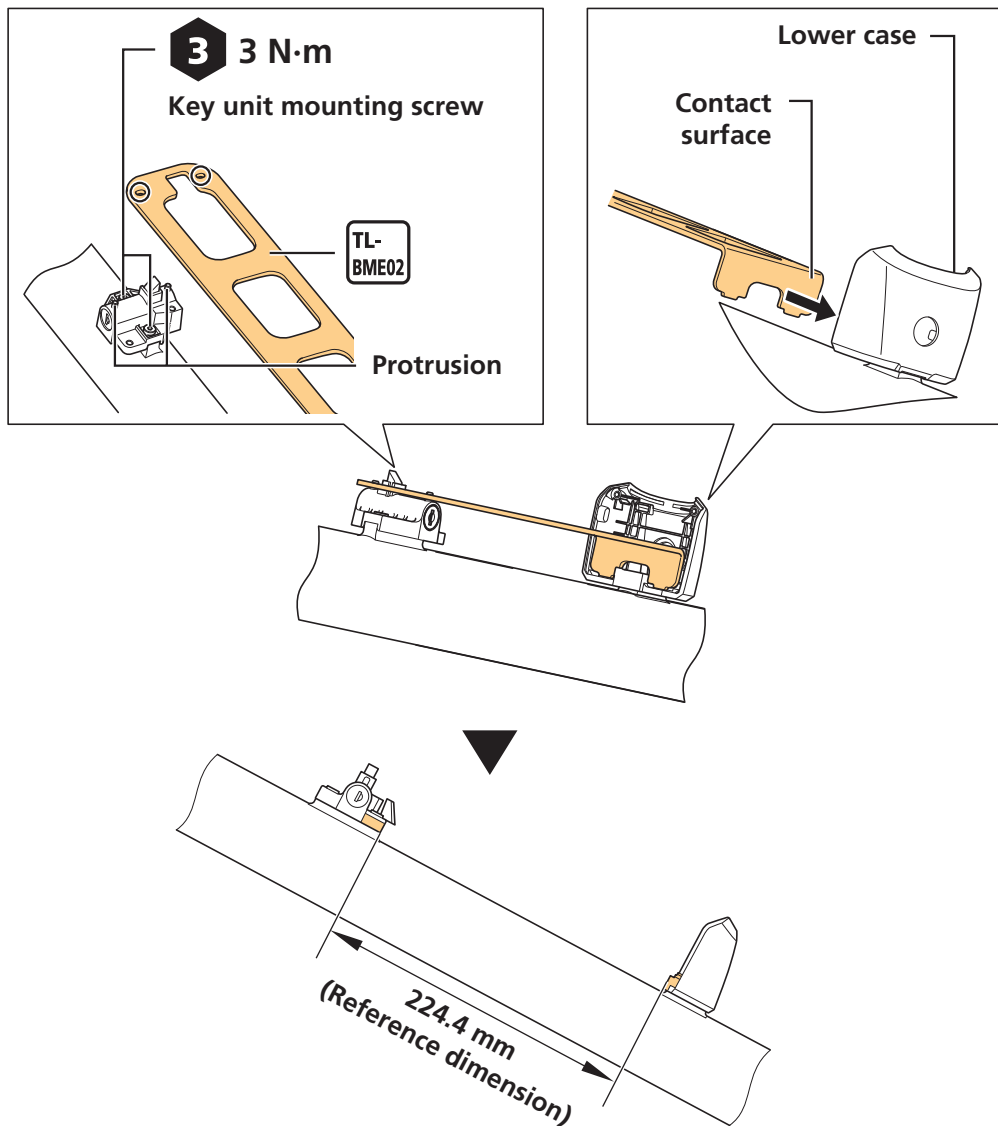

4. Install the key unit cover.

- (1) Temporarily install the key unit cover.
- (2) Try attaching and removing the battery, and check the following:
 - The battery can be smoothly attached and removed
 - There is no rattling in the key unit cover or battery that could result in abnormal noise when riding

(3) Secure the key unit cover.

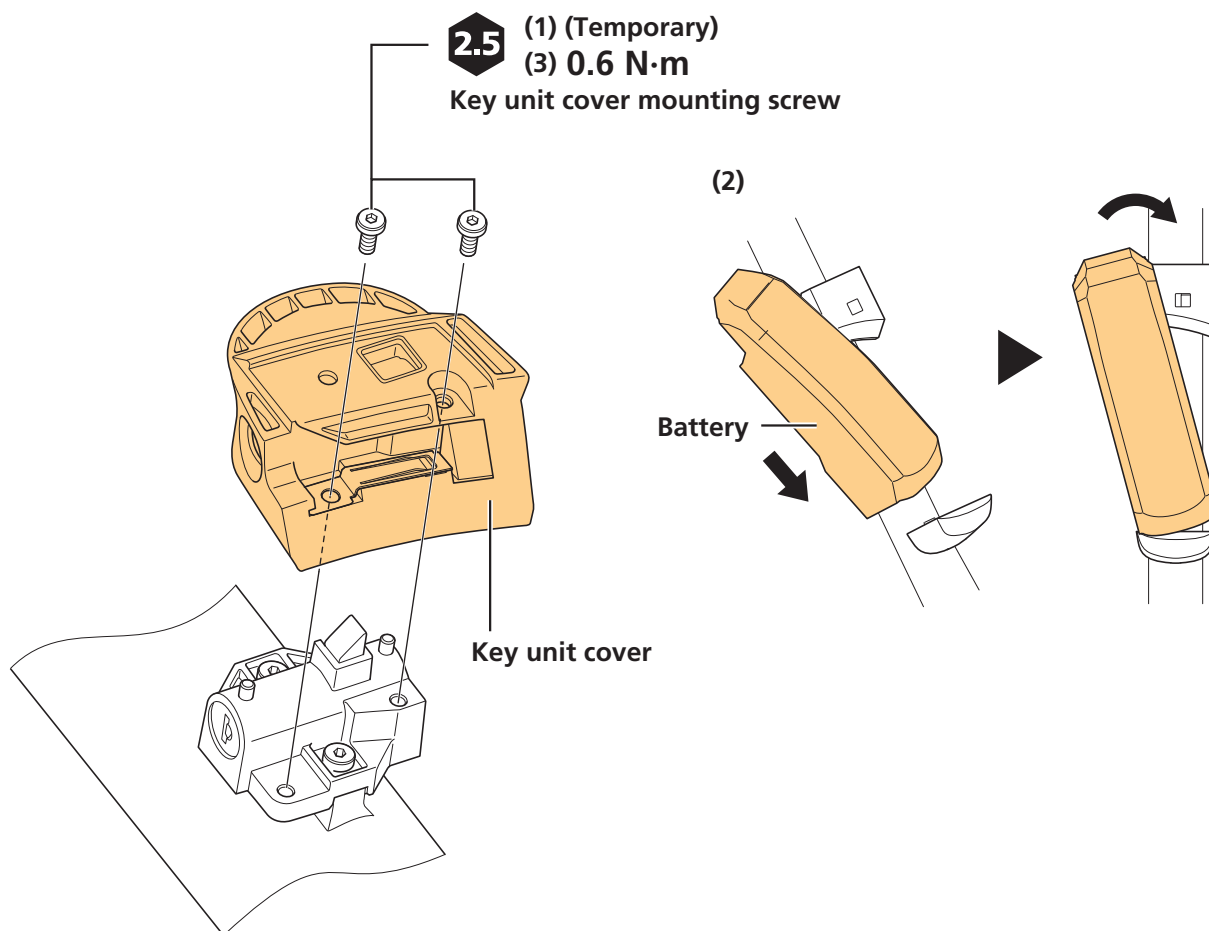

5. Install the upper case.

- (1) Pass the power cord from the upper case through the hole in the lower case.
- (2) Set the upper case to the lower case.

* Make sure that the bellows on the base of the power cord is exposed from below the lower case.

- (3) Secure the upper case.

- (4) Pass the power cord through the frame and leave it hanging over the drive unit installation area.

BM-E8010

- (3) Upper case mounting screw

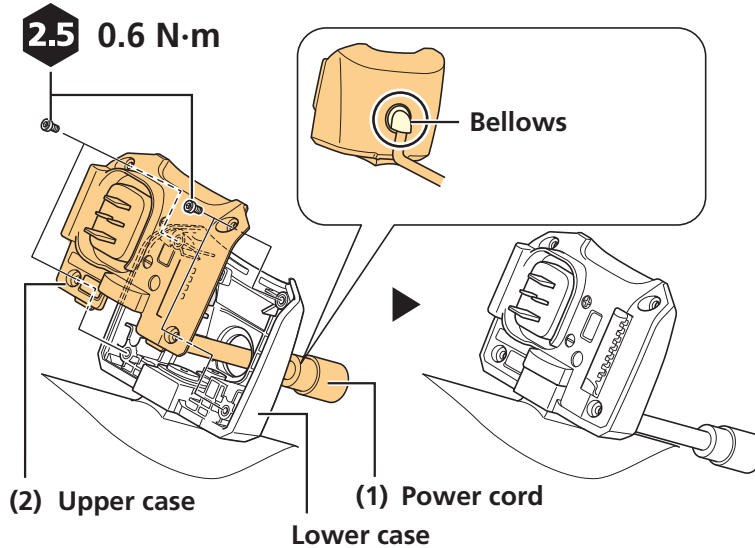

BM-E8016

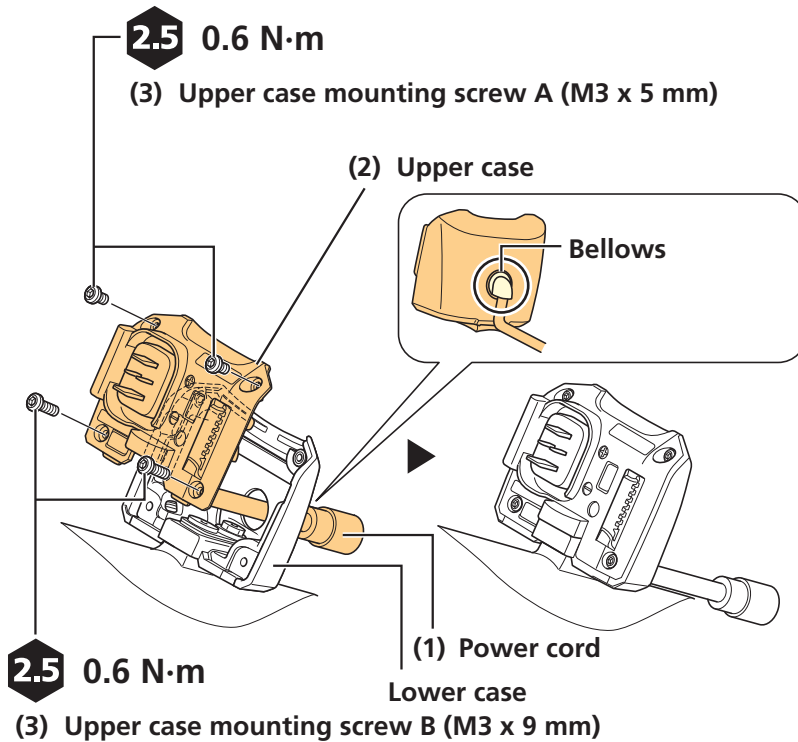

Integrated mount type

Depending on the frame, it may be installed at a location different from the position specified in this section.

▶ BM-E8020

If the following cables will be internally routed through the frame, route them through the frame before installing BM-E8020:

- Electric wire
- Brake hose, brake cable, and shift cable

When installing BM-E8020 inside the frame, be careful that the cables listed above are not pinched.

The SHIMANO original tool TL-BME03 can be used to easily determine the installation location for the key unit.

1. Install the lower case to the frame.

- (1) Ensure any cables run internally through the down tube pass through the mount installation area.
- (2) Install the lower case on the lower side of the down tube.

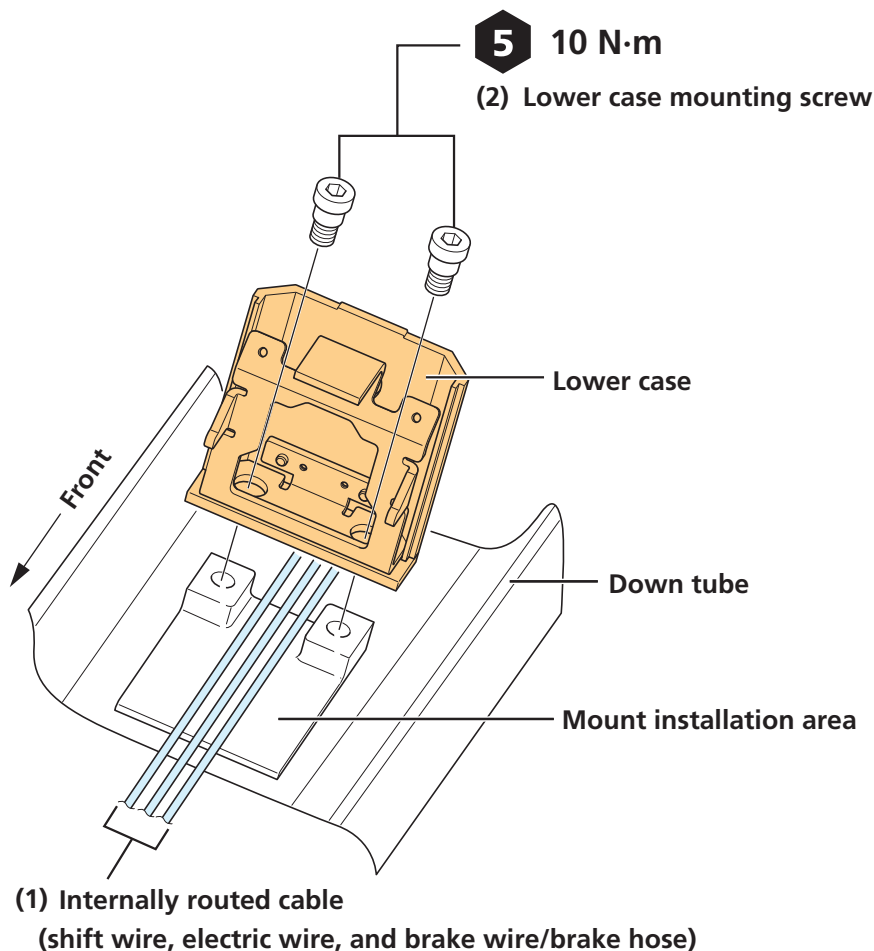

2. Install the upper case.

- (1) Pass the power cord from the upper case through the hole in the lower case.
- (2) Install the upper case to the lower case.

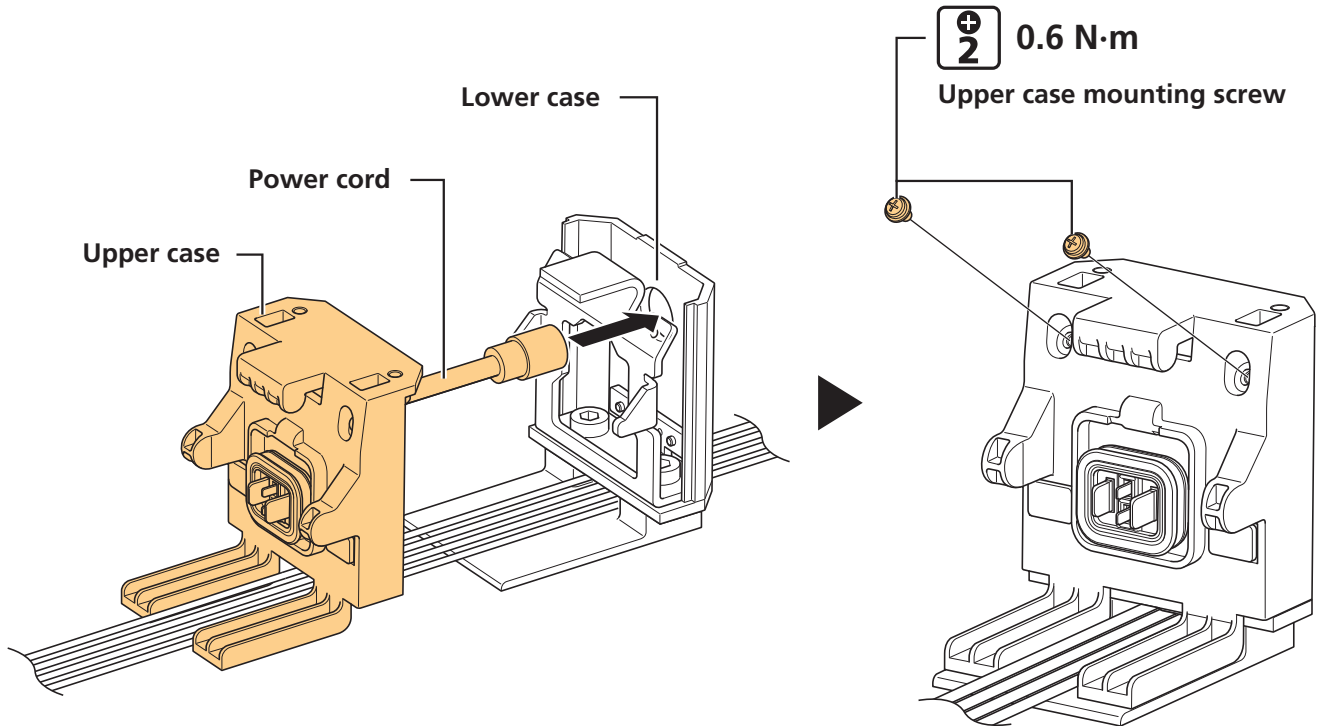

3. Install the cylinder to the key unit.

Key cylinders are not included with SHIMANO products.

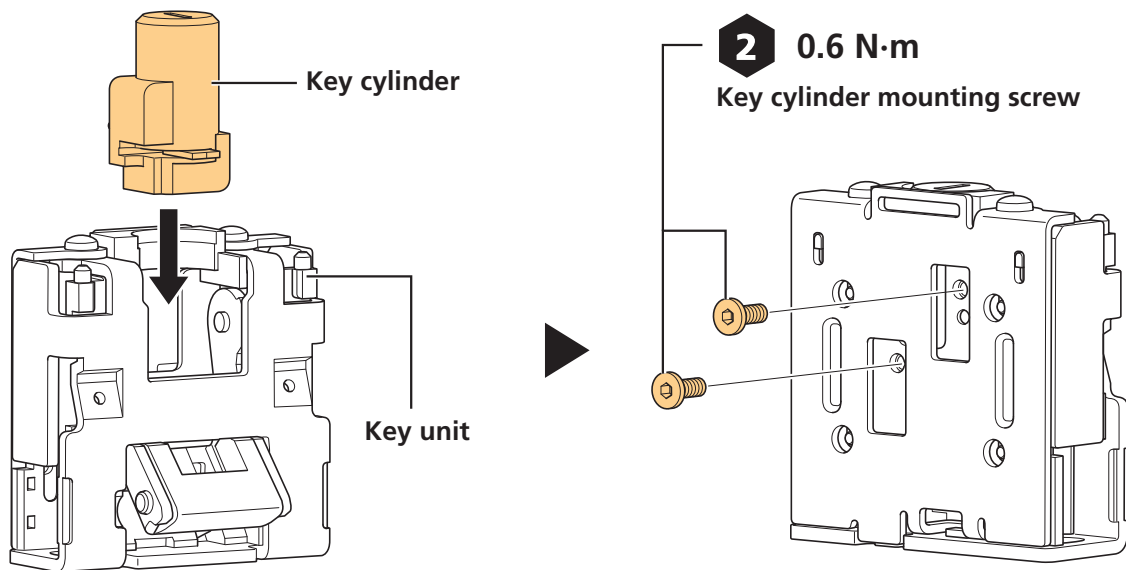

4. Temporarily install the key unit.

- (1) Ensure any cables run internally through the down tube pass through the mount installation area.
- (2) Temporarily install the key unit on the upper side of the down tube.

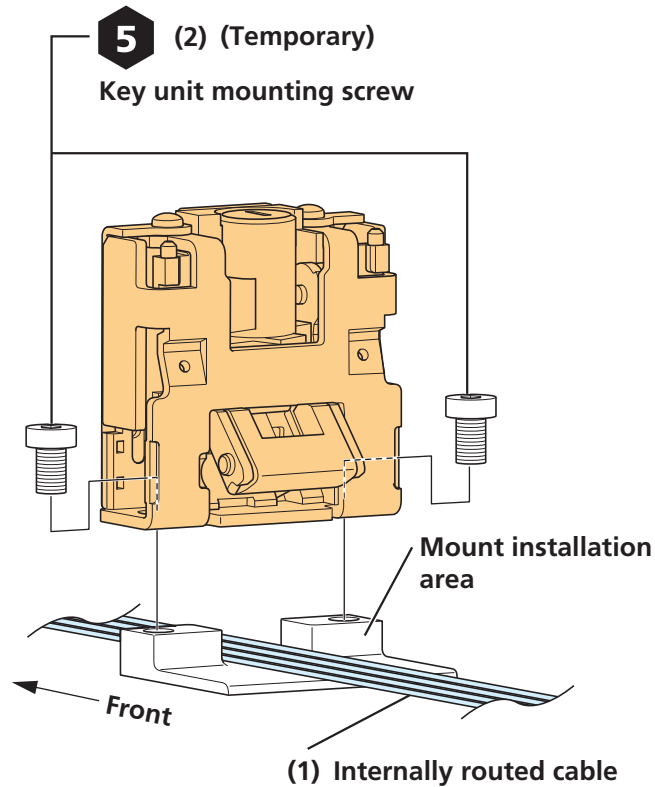

5. Use TL-BME03 to determine the location for the key unit.

- (1) Align the two protrusions on the key unit with the holes in TL-BME03.

- (2) Adjust the location of the key unit so that the contact surface of TL-BME03 will be pushed against the lower case as shown in the figure.

* Be careful not to apply excessive force.

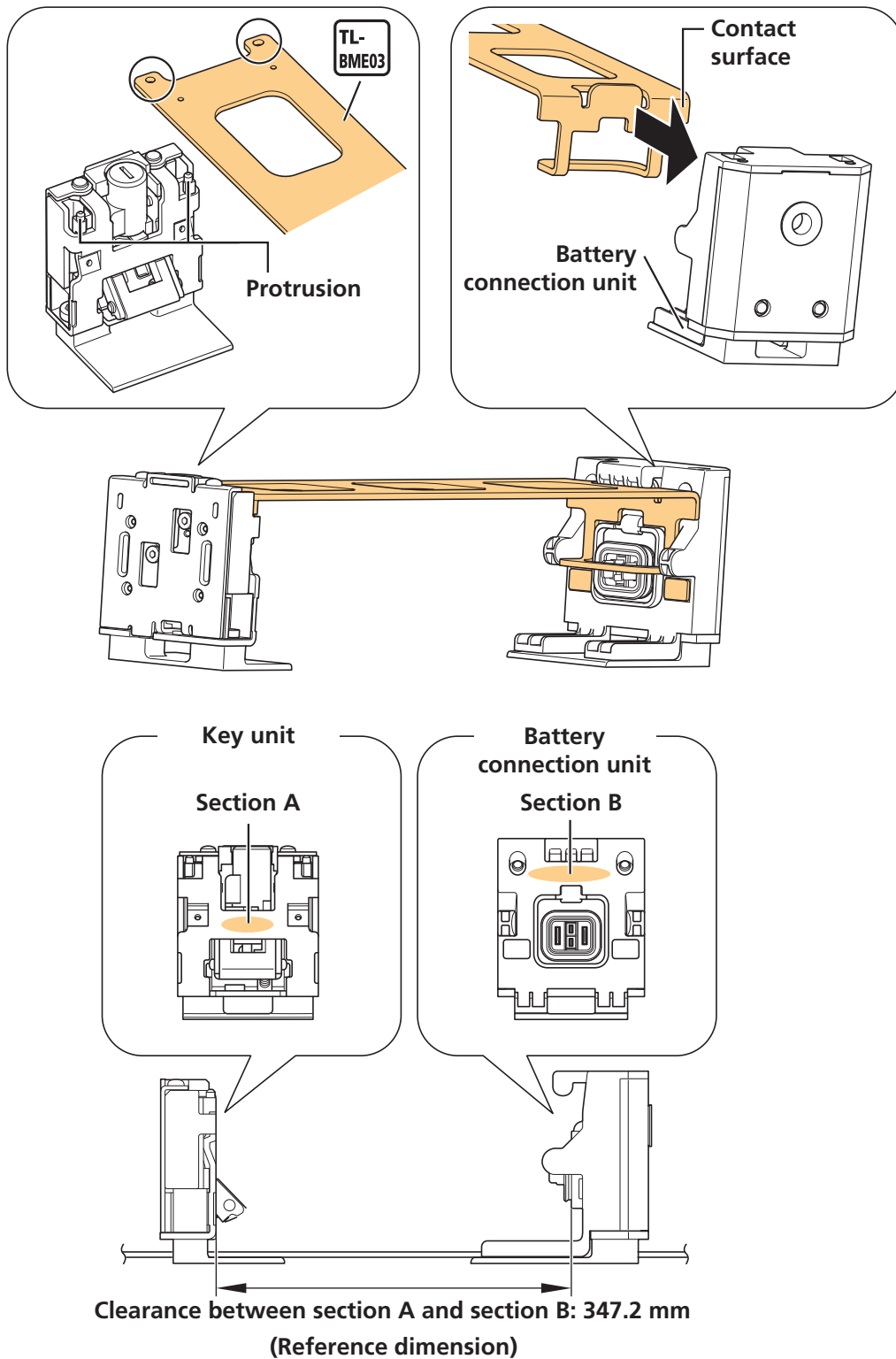

6. Tighten the key unit mounting screws.

- (1) Tighten the key unit mounting screws.

- (2) Remove TL-BME03.
- (3) Install the retention rubber.

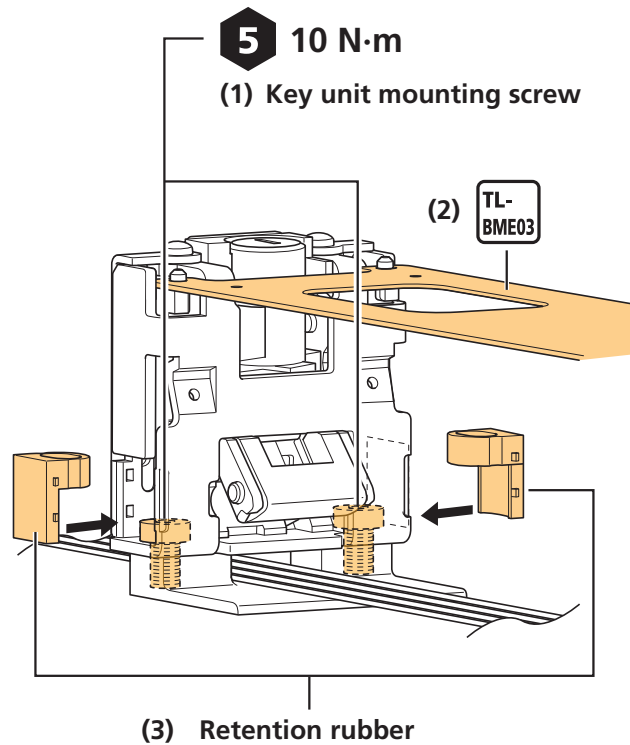

7. Install the key unit cover.

- (1) Temporarily install the key unit cover.
- (2) Try attaching and removing the battery, and check the following:
 - The battery can be smoothly attached and removed
 - There is no rattling in the key unit cover or battery that could result in abnormal noise when riding
- (3) Secure the key unit cover.

- (4) Pass the power cord through the frame and leave it hanging over the drive unit installation area.

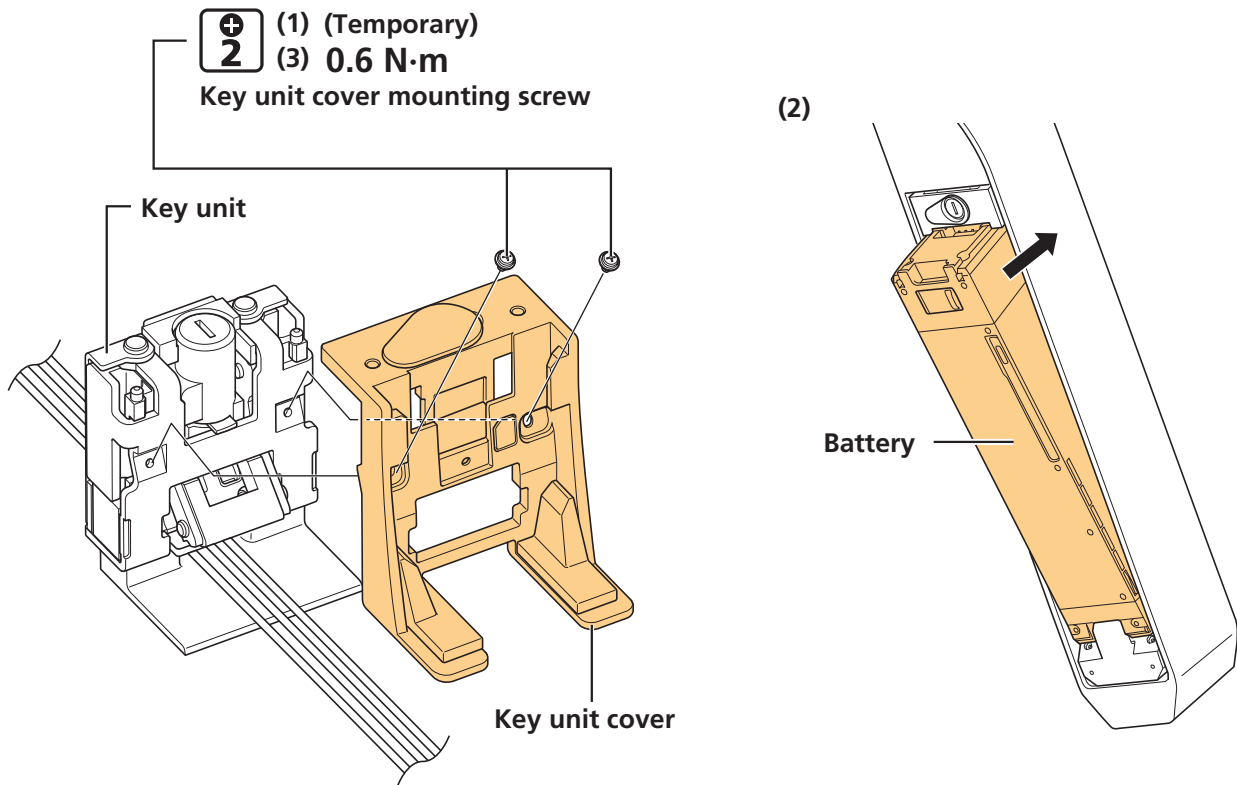

▶ BM-E8030 / BM-E8031

The SHIMANO original tool can be used to easily determine the installation location for the key unit.

Use the appropriate SHIMANO original tool according to the battery that is used.

- When the battery is the BT-E8035: TL-BME04
- When the battery is the BT-E8035-L / BT-E8036: TL-BME05

TECH TIPS

- TL-BME04 is composed of TL-BME04-L and TL-BME04-S.
- TL-BME05 is composed of TL-BME05-L and TL-BME04-S.
- The BM-E8031 has an unlock pin unit installed, which enables the battery to be unlocked with a hexagon wrench instead of a key. For information on the method for externally accessing the unlock pin unit, refer to the manual for the frame in advance.

1. Temporarily install the lower bracket.

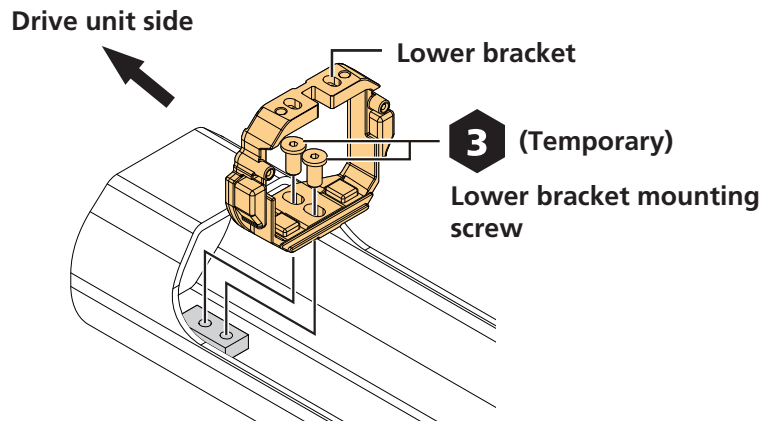

2. Temporarily install the upper bracket with the installation position determined.

BM-E8030

Install the TL-BME04-S to the upper bracket, and temporarily install the upper bracket so that the dummy key cylinder can be seen in the center position from the frame key hole. Proceed to the next procedure with the TL-BME04-S installed.

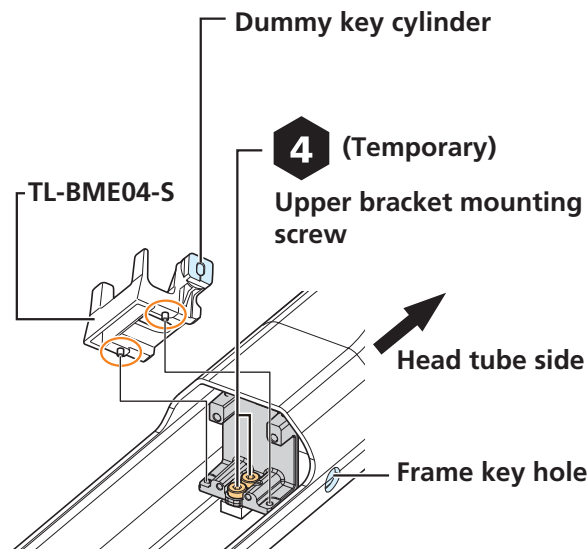

BM-E8031

Combine the latch base and the upper bracket, and temporarily install the upper bracket in a position where the unlock pin unit can be externally accessed without a problem.

When temporary installation of the upper bracket is complete, remove the latch base.

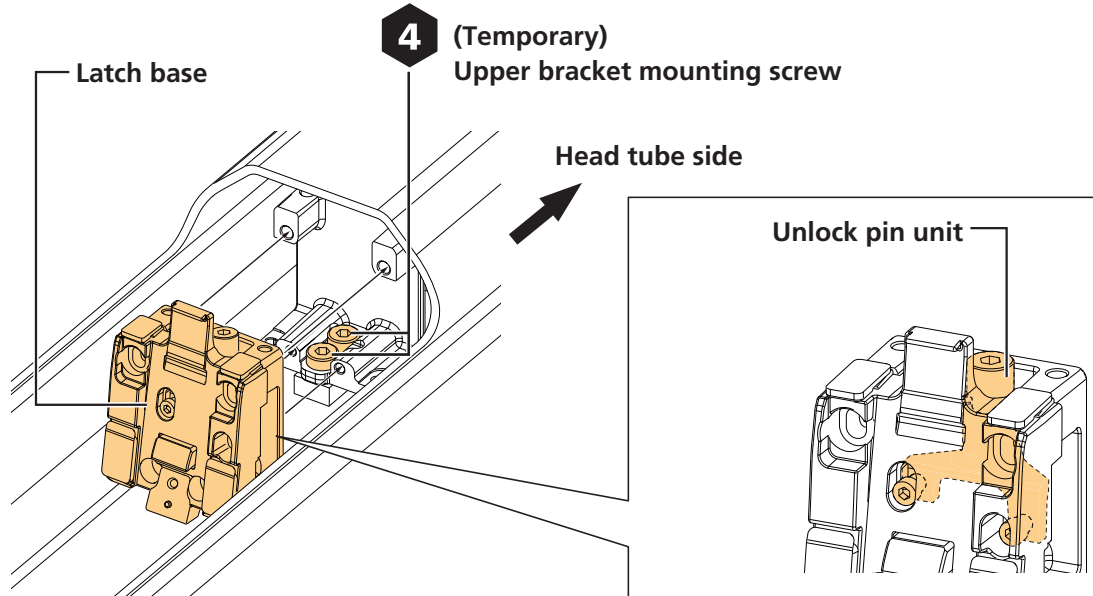

3. Secure the upper bracket while using the SHIMANO original tool to make the upper bracket and lower bracket parallel.

(1) Install the SHIMANO original tools as shown in the figure.

- (2) Check that the SHIMANO original tool is making firm and even contact with the contact surface of the upper bracket and lower bracket, then secure the upper bracket.

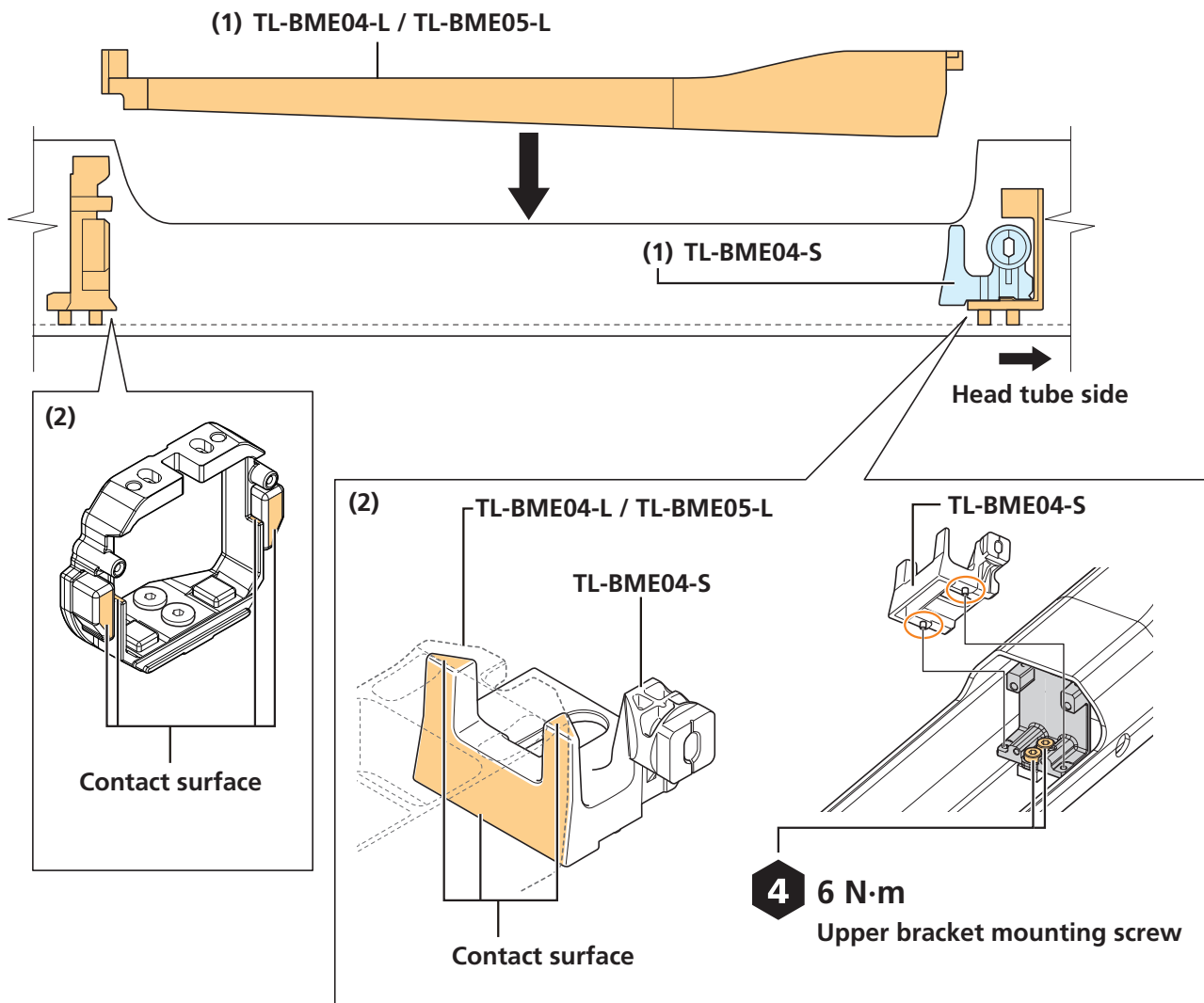

NOTICE

- The battery cannot be retained properly unless the upper bracket and lower bracket are parallel. Adjust the SHIMANO original tool so that it is making firm and even contact with both sides of the left and right contact surface of the lower bracket.

4. Install the latch base to the upper bracket.

BM-E8030

First install the key cylinder to the latch base. Key cylinders are not included with SHIMANO products.

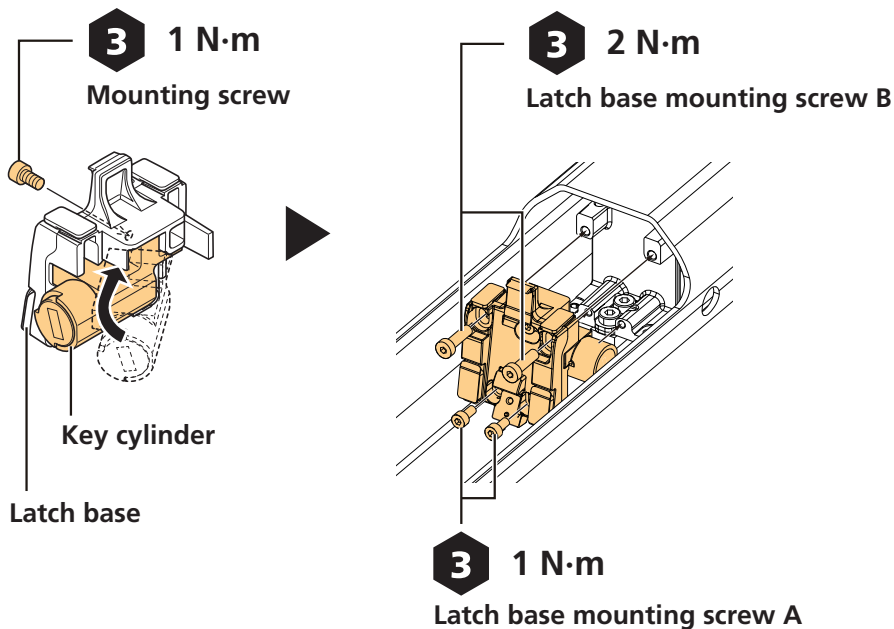

BM-E8031

After installing the latch base, adjust the installation height of the unlock pin unit if necessary.

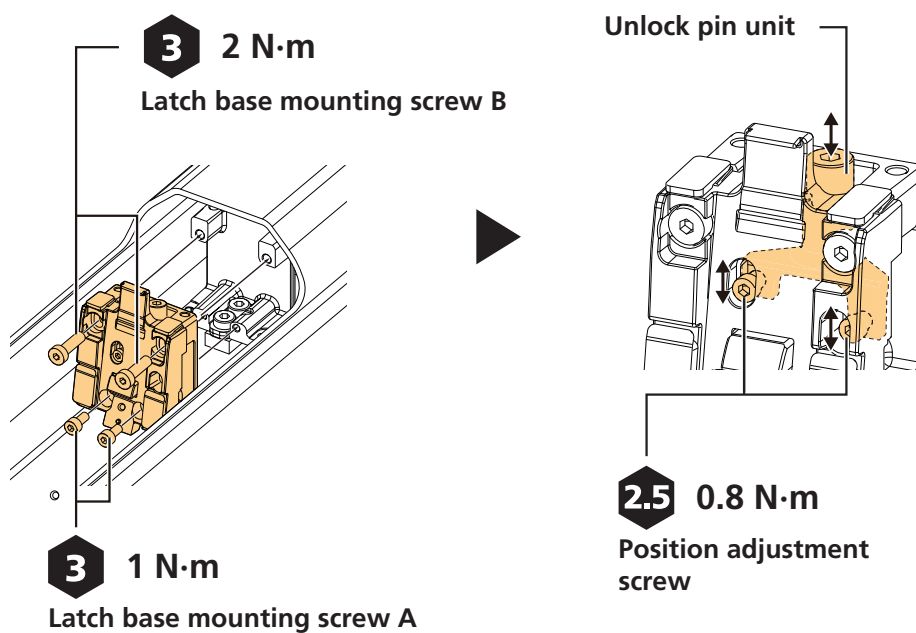

5. Install the spring unit if necessary.

For a frame where the battery is removed downwards

Hold the spring unit stable when installing it so that it does not turn when tightening the mounting screw.

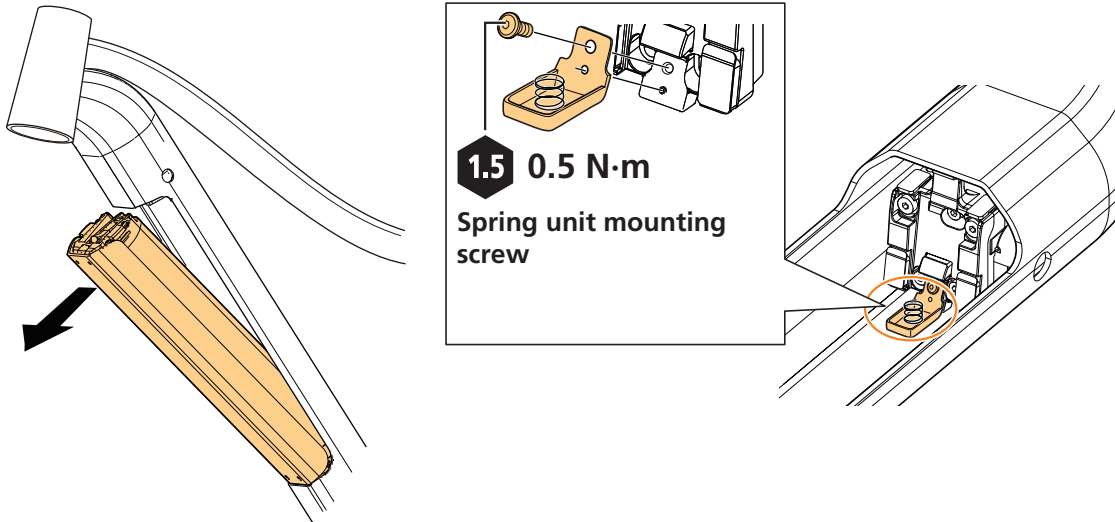

For a frame where the battery is removed upwards

Do not install the spring unit.

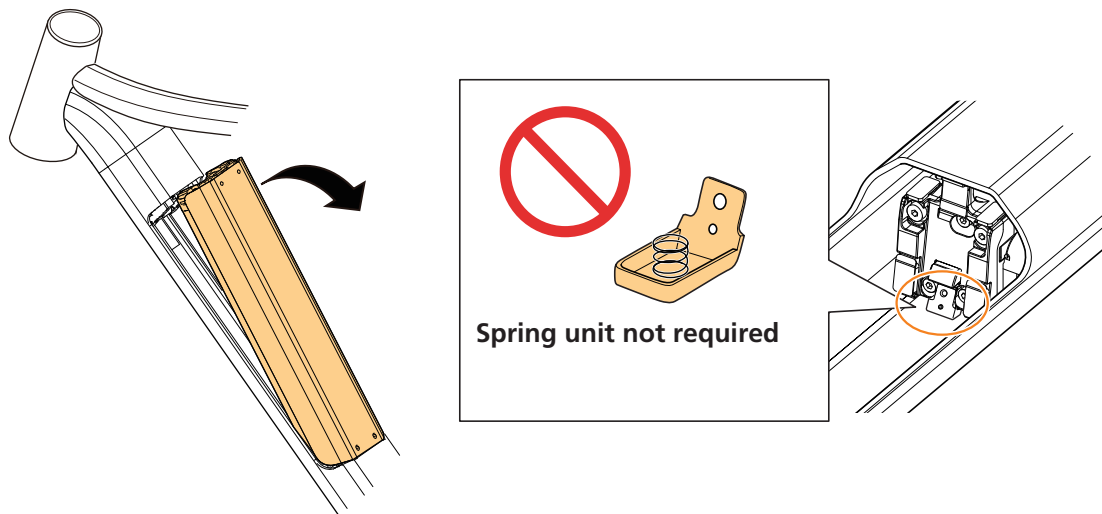

6. Secure the lower bracket.

(1) Set the SHIMANO original tools as shown in the figure.

- (2) Check that the SHIMANO original tool is making firm and even contact with the contact surface, then secure the lower bracket.

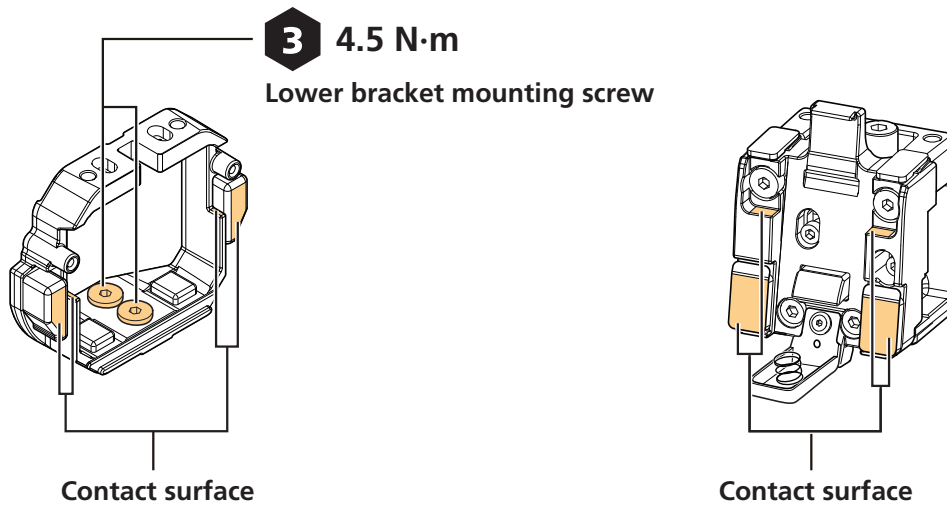
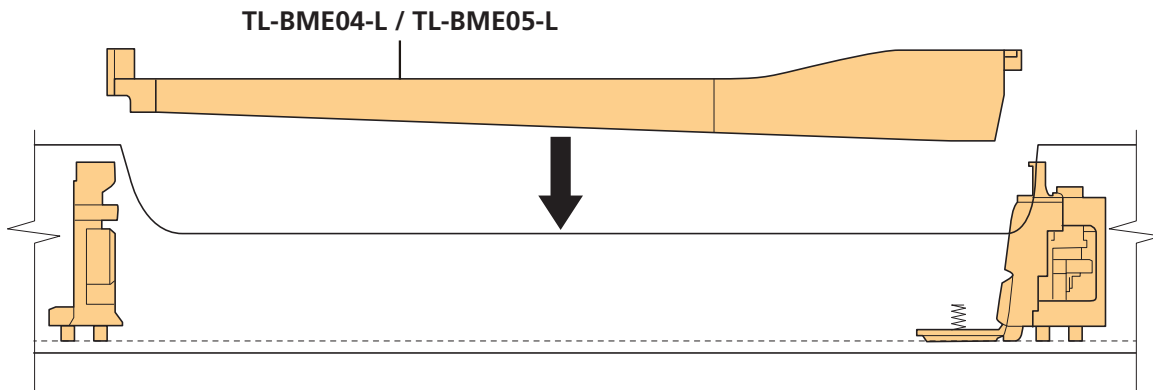

7. Install the connector unit.

The cables may need to be connected prior to installing the connector unit, depending on the frame design.

- (1) Push the connector unit into the lower bracket.
- (2) Use the limit screw to secure the connector unit.

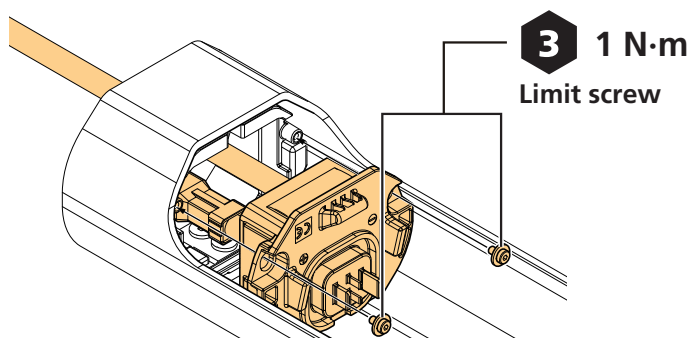

Installing the satellite charging port

EW-CP100

NOTICE

- The work procedure and tightening torque may vary depending on the design of the frame. Contact a distributor for details.

1. Install the connection cable.

The connection cable may need to be connected after installing the satellite charging port, depending on the design of the frame.

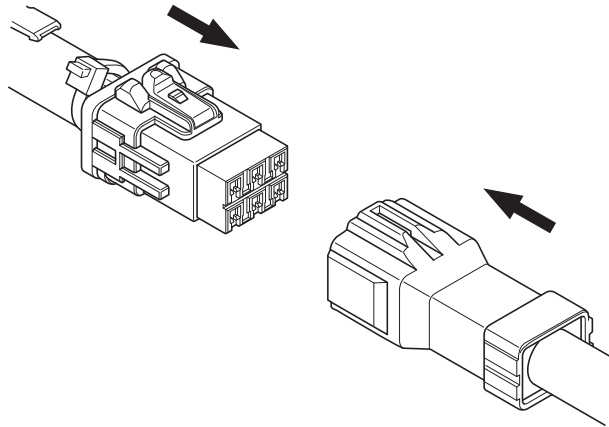

2. Install the satellite charging port.

- (1) Open the charging port cap, and insert the satellite charging port into the frame after ensuring that section A is not exposed.

(2) Close the charging port cap, and secure the satellite charging port.

(1)

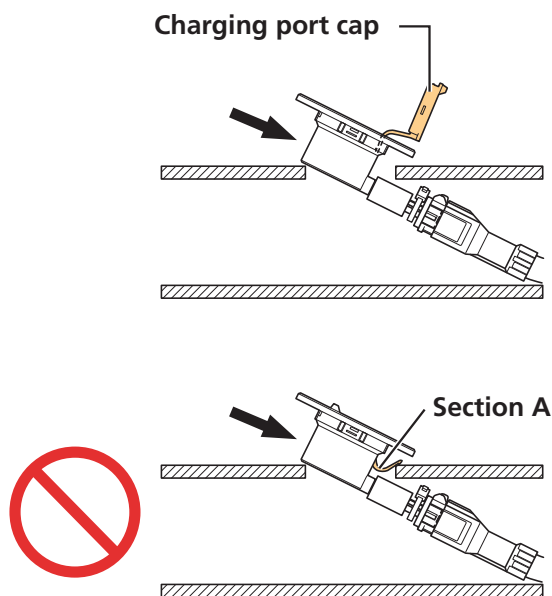

(2)

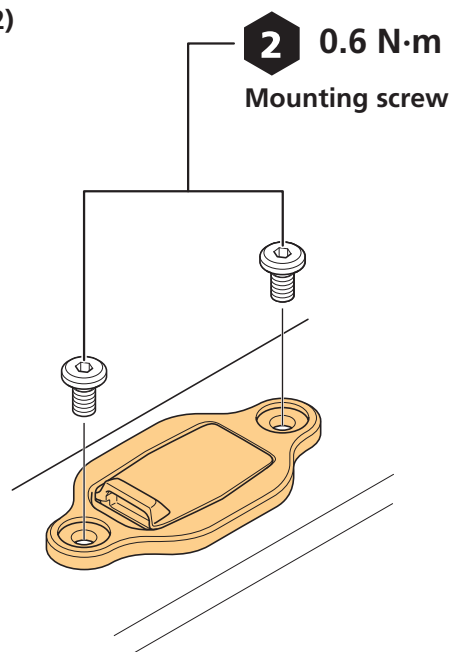

NOTICE

- Section A in the figure is part of the charging port cap. When installing the satellite charging port, be careful that section A is not pinched by the frame.

Installing the satellite system ON/OFF switch

EW-SW100 / EW-SW300

NOTICE

- The work procedure and tightening torque may vary depending on the design of the frame. Contact a distributor for details.

1. Connect the electric wire of the satellite system ON/OFF switch.

- The electric wire may need to be connected after installing the satellite system ON/OFF switch, depending on the design of the frame.

- The electric wire of the satellite system ON/OFF switch is connected to junction [B] in the figure, but it can be connected directly if there is a free E-TUBE port on the drive unit.

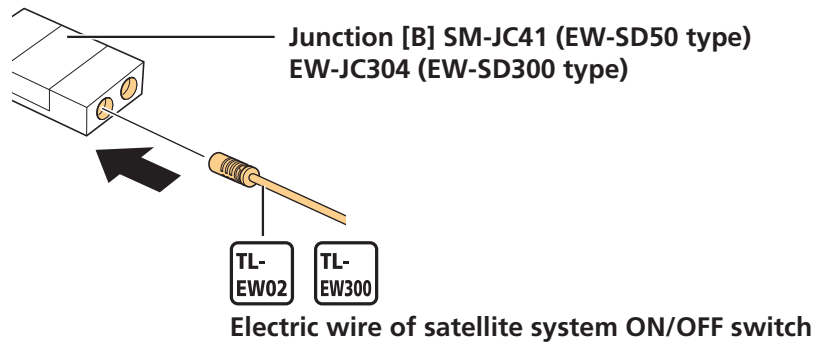

2. Install the satellite system ON/OFF switch.

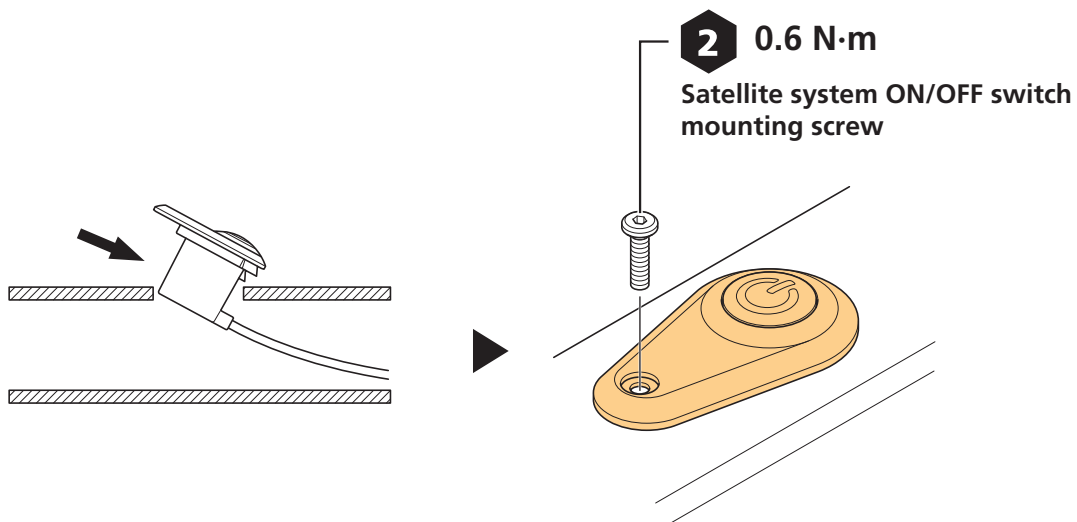

NOTICE

- This may vary depending on the design of the frame. For example, there may or may not be an adapter, or the hook may differ. Contact a distributor for details.

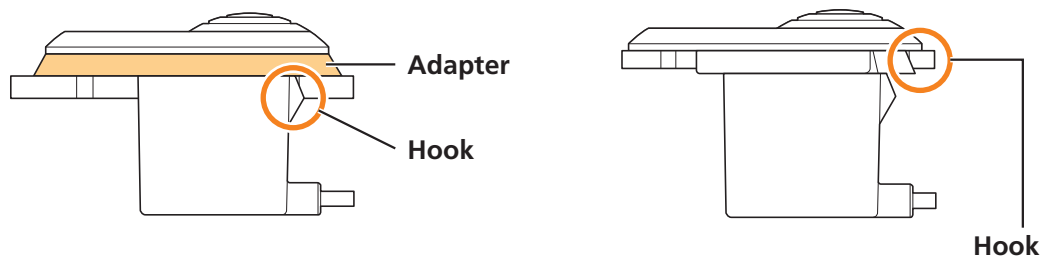

Maintenance

Replacing the double latch plate

For models: BM-E8030 / BM-E8031

1. Remove the double latch plate.
2. Install a new double latch plate.

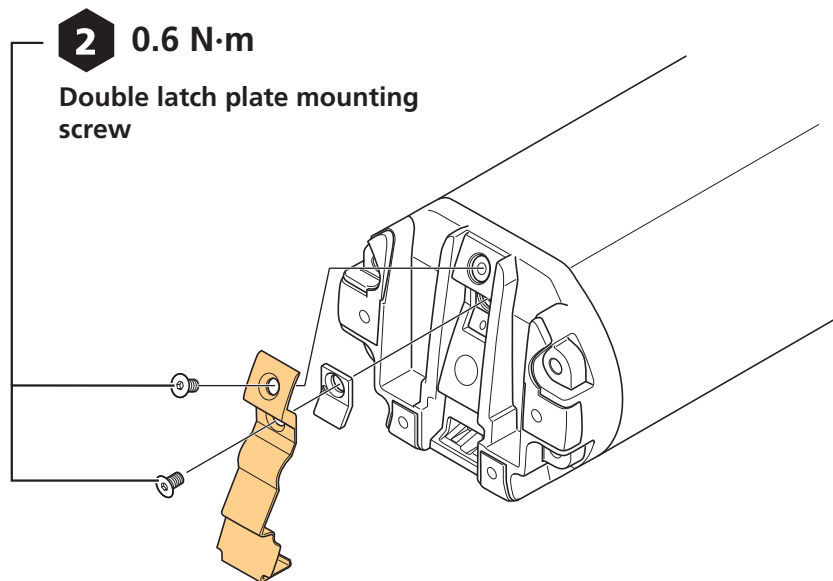

Replacing the spring unit

For models: BM-E8030 / BM-E8031

Refer to "Installing the battery mount" for detailed instructions.

1. Remove the spring unit and replace it with a new spring unit.

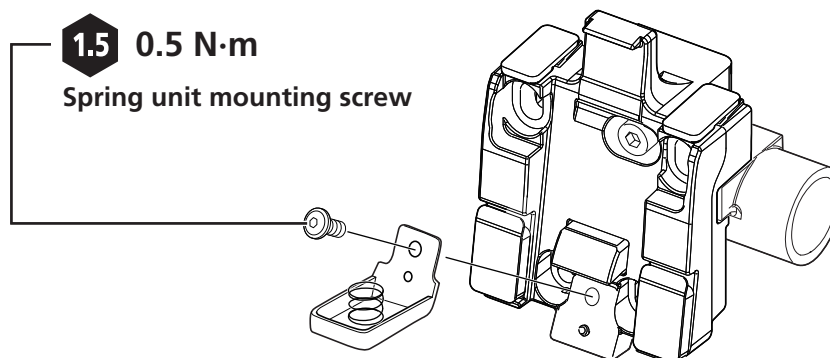

Replacing the charging port cap

For models: EW-CP100

1. Remove the charging port cap.

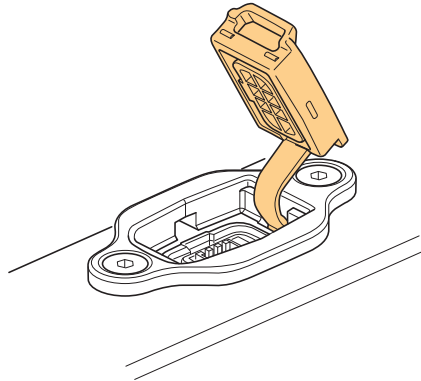

2. Replace with a new charging port cap.

As shown in the figure, push it in with your fingers.

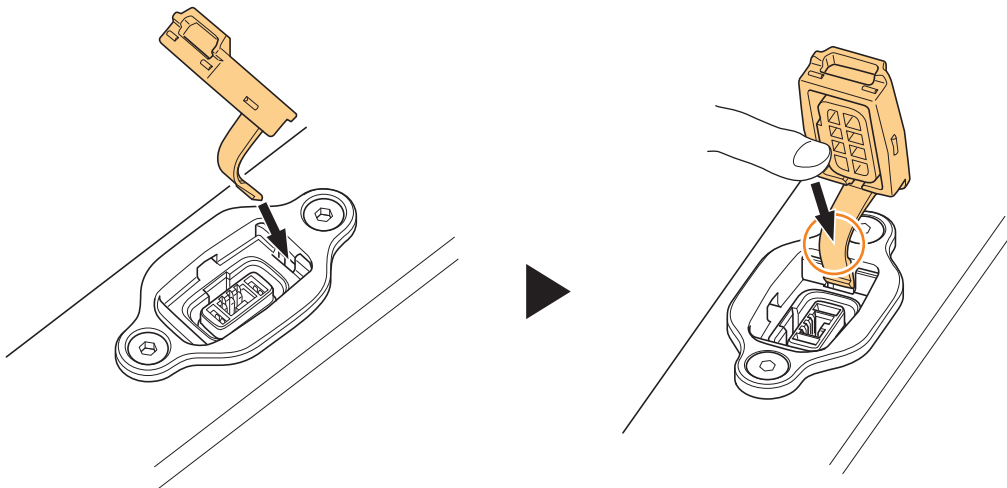

Charging of the satellite system ON/OFF switch

For models: EW-SW100, EW-SW300

The power does not turn ON if the built-in battery of the satellite system ON/OFF switch is not adequately charged. Follow one of the methods below to charge it. It takes a maximum of two hours to charge the built-in battery.

- Charge the built-in battery while the (main) battery is mounted on the bicycle. (BM-E6000 / BM-E6010 / EW-CP100 only)
- When the (main) battery is fully charged, charging of the built-in battery of the satellite system ON/OFF switch also stops automatically.

- The power can be turned ON using the power button of the (main) battery.
- The power automatically turns OFF if the bicycle is stopped for 10 minutes. When charging for more than 10 minutes, operate any switch on the bicycle or turn the crank to prevent the power from turning OFF.
- Connect the satellite system ON/OFF switch to a PC to charge from E-TUBE PROJECT.

This section describes how to charge the satellite system ON/OFF switch from the PC version of E-TUBE PROJECT.

NOTICE

- To charge the satellite system ON/OFF switch from E-TUBE PROJECT, the version of E-TUBE PROJECT must be 3.4.3 or later.

TECH TIPS

- For details, refer to the user's manual for E-TUBE PROJECT for Windows.

1. Remove the drive unit cover on the terminal block side.

The drive unit cover on the terminal block side differs according to the drive unit. Check the dealer's manual of the drive unit for details.

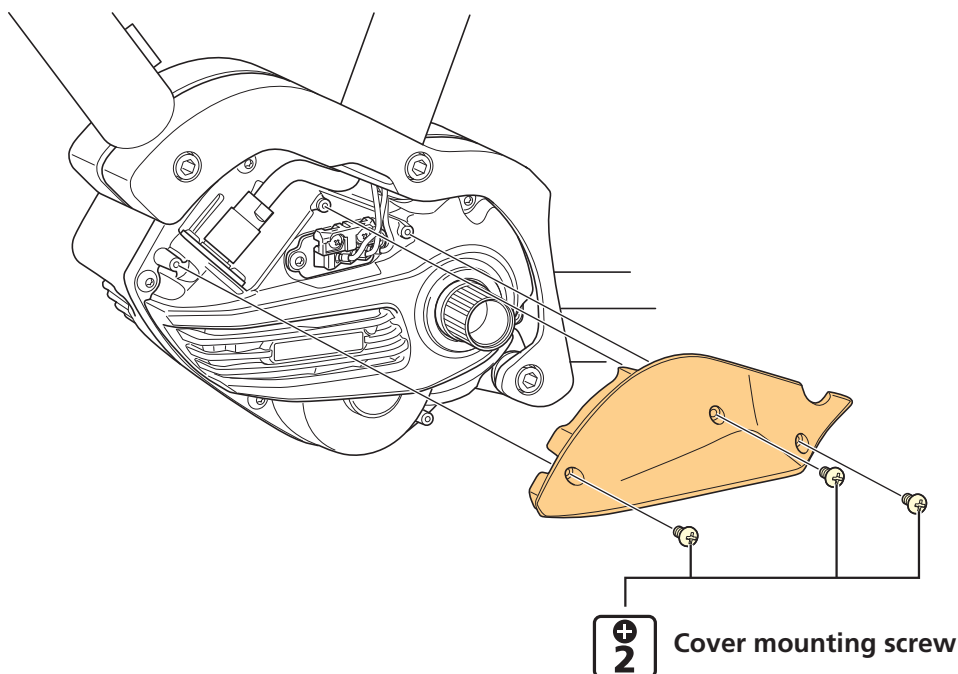

2. Connect the satellite system ON/OFF switch and the PC.

- (1) Connect the electric wire of the satellite system ON/OFF switch to the PC linkage device as shown in the figure.

(2) Connect the PC linkage device and the PC.

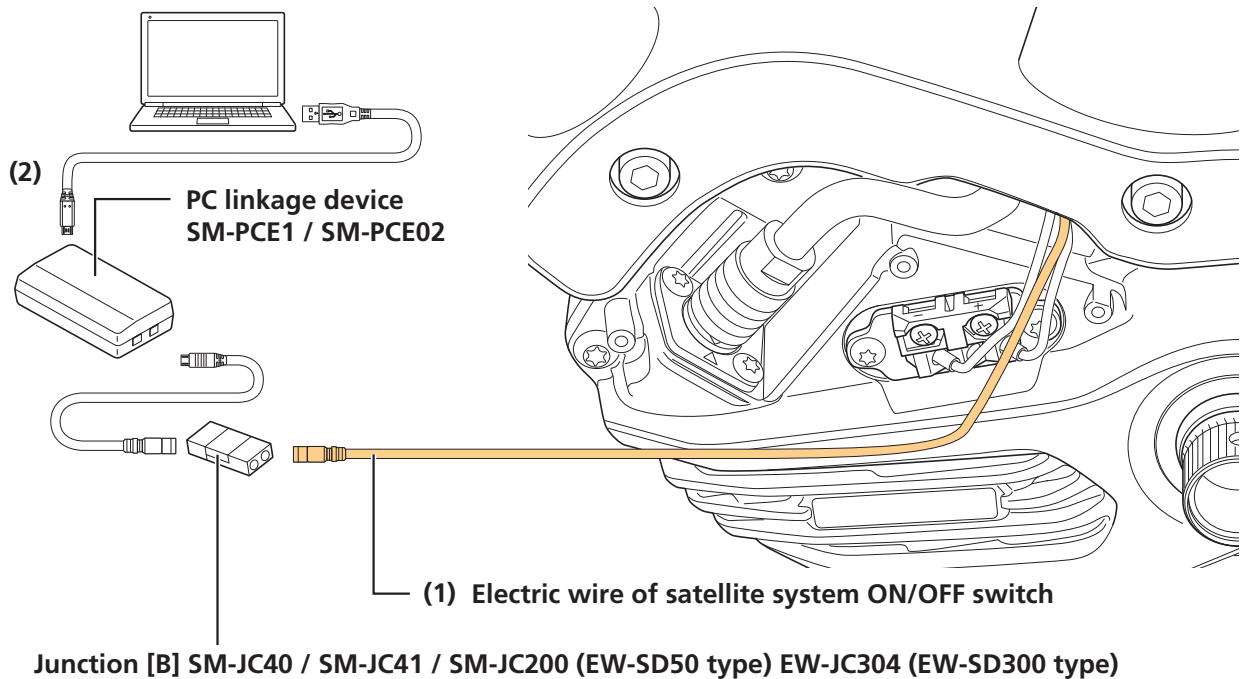

NOTICE

- It is necessary to connect the satellite system ON/OFF switch and PC linkage device via junction [B] as shown in the figure.
- When connecting a device compatible with the EW-SD300 to the PC linkage device, use a conversion adapter (EW-AD305) to connect the wire to the EW-SD50.
- The drive unit and satellite system ON/OFF switch may be connected via junction [B], depending on the bicycle. When connecting to junction [B], remove the electric wire connected to the drive unit from junction [B].

3. Start E-TUBE PROJECT.

If E-TUBE PROJECT for Windows is version 3.4.3

Execute [Connection check].

- Charging of the built-in battery starts when the satellite system ON/OFF switch is detected.
- The LED lamp on the satellite system ON/OFF switch flashes while charging. When charging is complete, the LED turns off.

If E-TUBE PROJECT for Windows is version 4.0.2 or later

Click [Error check] on the [MAINTENANCE] tab. Next, check the state of the satellite system ON/OFF switch on the screen and click [Charge].

- The estimated time until charging is complete is displayed on the screen.
- The LED lamp on the satellite system ON/OFF switch flashes while charging. When charging is complete, the LED turns off.

NOTICE

- If charging the satellite system ON/OFF switch is difficult using any of the methods shown in this section due to the specifications of the bicycle, etc., consult a distributor.

Troubleshooting

The battery indicates errors using LED lighting patterns. Refer to the user's manual (<https://si.shimano.com/um/7GP0A>). If the error persists, contact a distributor. Other troubleshooting is included in the user's manual.

SHIMANO

SHIMANO NORTH AMERICA BICYCLE, INC.

One Holland, Irvine, California 92618, U.S.A. Phone: +1-949-951-5003

SHIMANO EUROPE B.V.

High Tech Campus 92, 5656 AG Eindhoven, The Netherlands Phone: +31-402-612222

SHIMANO INC.

3-77 Oimatsu-cho, Sakai-ku, Sakai City, Osaka 590-8577, Japan

Please note: specifications are subject to change for improvement without notice. (English)

© Nov. 2020 by SHIMANO INC. ITP