

WURLITZER[®] ELECTRONIC PIANO

Service Manual

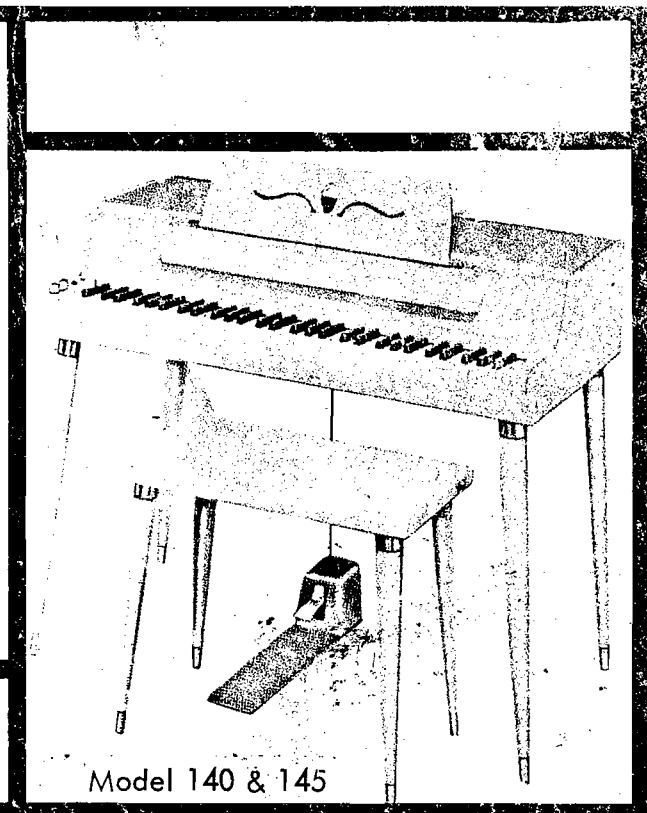
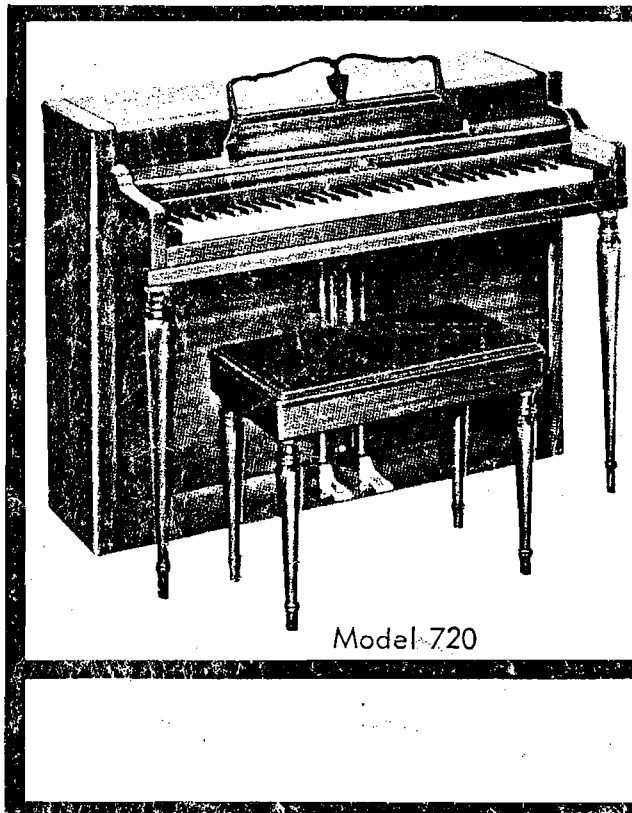

The WURLITZER Company DE KALB, ILLINOIS

WURLITZER ELECTRONIC PIANOS
 MODELS 140, 140B, 145, 700 & 720B

SPECIFICATIONS & DESCRIPTION

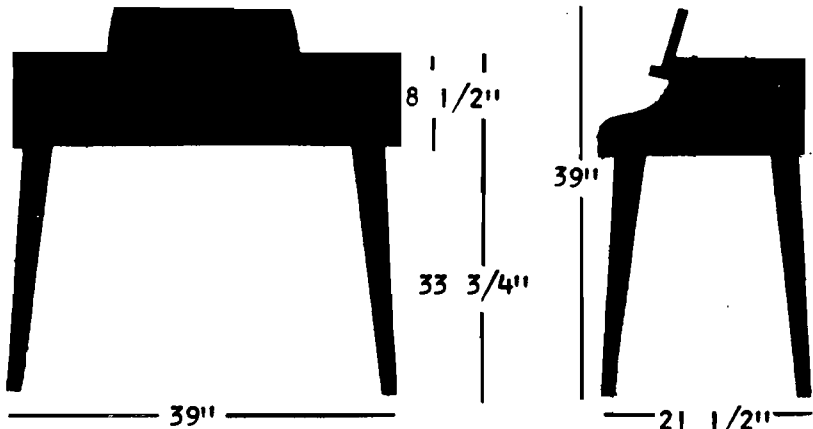

PIANO -
 Height 33 3/4" Standing
 Height 8 1/2" Packed
 Width 39 "
 Depth 21 1/2"

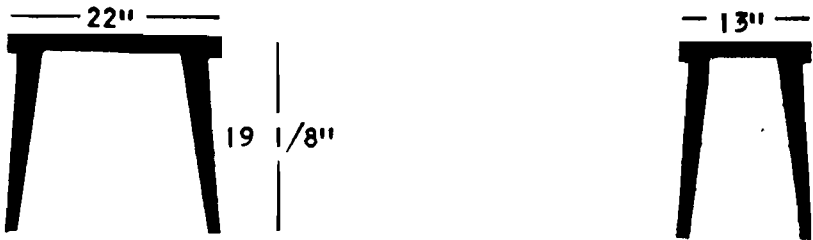

BENCH -
 Height 19 1/8" Standing
 Width 22 "
 Depth 13 "

WEIGHT - 81 Pounds
 FINISH - Sandstone Beige

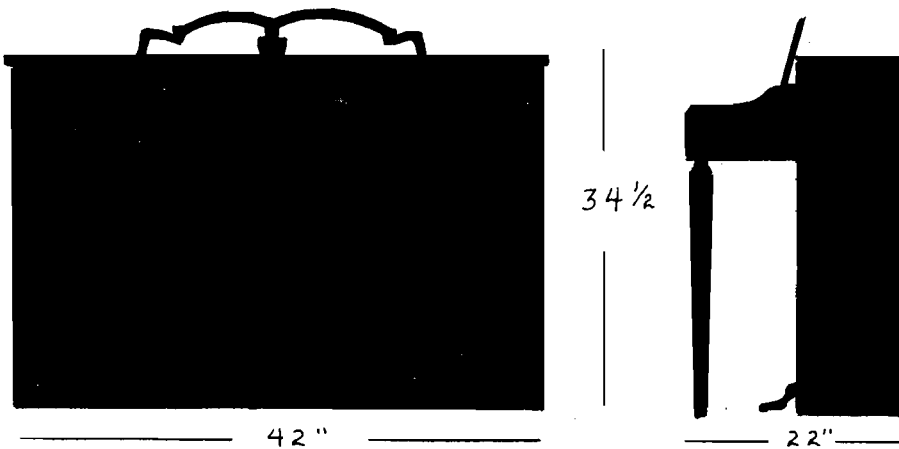

PIANO -
 Height 34 1/2"
 Width 42 "
 Depth 22 "
 BENCH -
 Height 18 1/2" Standing
 Width 22 1/2"
 Depth 13 1/2"

WEIGHT - 110 Pounds
 FINISH - Brown Mahogany

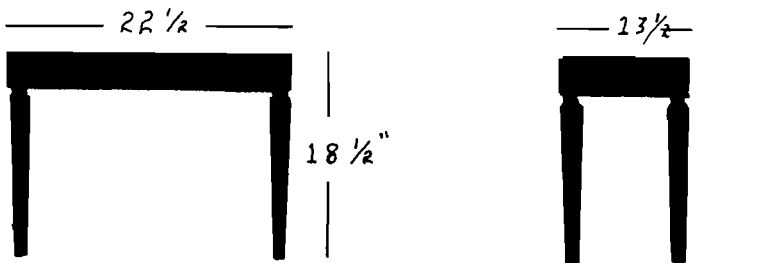

MUSICAL RANGE : 64 notes, A-13 (55,000 C.P.S.) to C-76
(2093.005 C.P.S.)

KEYBOARD : naturals, white Implex over basswood. Sharps,
black molded plastic.

ACTION : Wurlitzer-developed and built special 64-note
action.

HAMMERS : 3-ply moldings of 1/16" maple, with maple
crossbanding. White mothproofed felt, with
underfelt in bass section. Felt attached to
moldings with water-resistant glue.

TONE GENERATORS : Sandvik Swedish steel reeds, electrolytically
coated. Reeds vibrate in an electrically
polarized field when struck by the hammers.

AMPLIFIER

MODEL 145 and 720 : Tube Compliment.

MODEL 140 : Germanium transistor compliment.

MODEL 140B and 720B: Silicone and germanium transistor compliment.

SPEAKER

MODEL 145 and 140 : 6" X 9" oval P.M. 4 ohm voice coil.

MODEL 720 : 12" round P.M. 4 ohm voice coil.

MODEL 140B and 720B: 6" X 9" oval P.M. 8 ohm voice coil.

POWER REQUIREMENTS

MODEL 145 and 720 : 85 watts; operates from 117 volt, 60 Hertz AC.

MODEL 140 : 40 watts; operates from 117 volt, 60 Hertz AC.

MODEL 140B and 720B: 30 watts; operates from 117 volt, 60 Hertz AC.

AMPLIFIER DESCRIPTION MODEL 140

(Transistorized Amplifier)

Each of the 64 reeds in the reed bar is tuned for the specific resonant frequency at which it will vibrate when set in motion by striking a key. The pickup plates of the reed bar are mounted near the free end of the reeds, and a D.C. polarizing voltage is applied to the pickup plate through R-1 (refer to Schematic No. 650447). As the reed vibrates back and forth through the slot in the polarized pickup plate, a capacity change takes place at a rate corresponding to the reed's tuned frequency or pitch. The reed bar output signal voltage is applied to the base of TR-1, an impedance matching stage, through DC blacking capacitor C-1. The signal is taken from the emitter circuit of this stage and applied to the base of TR-2 through coupling capacitor C-4. A phono input is also connected to this coupling capacitor C-4. The amplified signal taken from TR-2's collector circuit is coupled to the arm of the volume control by coupling capacitor C-6 and isolation resistor R-10. The base of TR-4 is signal coupled to the high side of the volume control through coupling capacitor C-7. The output of TR-4 is coupled to the vibrato amplitude modulator, through coupling capacitor C-9 and isolation resistor R-33. The signal is then coupled through R-34 and C-13 to the base of TR-7 the driver stage for the push-pull output stage. The driver transformer, T-1, furnishes two signals of equal amplitude, but 180 out of phase, to the push-pull output stage consisting of TR-8 and TR-9. The outputs of TR-8 and TR-9 are direct-coupled to the 4 ohm console speaker. Note the closed circuit earphone jack which interrupts the audio signal to the speaker, when a set of earphones is inserted in the jack for "silent" practice.

A low frequency phase shift oscillator consisting of TR-3 is used in the vibrato circuit. The output of this oscillator is shunted across the vibrato control located on the cover assembly. The movable arm of the control is coupled through R-28 and C-10 to the base of TR-5. The amplified signal from C-9 is modulated with the vibrato signal from TR-3 at the junction of the varistors V-1 and V-2, by varying V-1 and V-2's resistance to signal ground. The depth of the vibrato is determined by the setting of the vibrato control, which is adjusted from the front panel by the musician.

Positive voltage for the reed bar is supplied by a conventional transformer-silicon rectifier type of power supply, consisting of T-2, R-44, R-45, R-46, C-22, C-23 and the silicon rectifier, SR. Positive and negative operating voltages for the amplifier are supplied through a standard bridge rectifier, BR.

AMPLIFIER DESCRIPTION MODEL 140B AND 720B

Each of the 64 reeds in the reed bar is tuned for the specific resonant frequency at which it will vibrate when set in motion by striking a hammer. The pickup plates of the reed bar are mounted near the free end of the reeds, and a D.C. polarizing voltage is applied to the pickup plate through R-1 (refer to Schematic #11-0547-S-4-E-1 and #652227-S-2-E-1). As the reed vibrates back and forth through the slot in the polarized pickup plates. A capacity change takes place at a rate corresponding to the reed's tuned frequency or pitch. The reed bar output signal voltage is applied to the base of TR-1, an impedance matching stage, through D.C. blocking capacitor C-2. The signal is taken from the emitter circuit of this stage and applied to the base of TR-2 through isolation resistor #9 and coupling capacitor #10. A phono input is also connected to this coupling capacitor C-10. The amplified signal taken from TR-2's collector circuit is coupled to the arm of the volume control by coupling capacitor #17. The base of TR-4 is signal coupled to the high side of the volume control through coupling capacitor #64. The driver transformer, T-70, furnishes two signals of equal amplitude, but 180 degrees out of phase, to the push-pull output stage consisting of TR-5 and TR-6. The outputs of TR-5 and TR-6 are direct-coupled to the 8 ohm console speaker. Note the closed circuit earphone jack which interrupts the audio signal to the speaker, when a set of earphones is inserted in the jack for "silent" practice.

A low frequency phase shift oscillator consisting of TR-3 is used in the vibrato circuit. The output of this oscillator is variably isolated by the vibrato control. The movable arm of the control is coupled through capacitor C-18 and resistor #19 to an incandescent lamp #20. This lamp, located along with a light dependant resistor #21 in a metal light shielding enclosure, varies in intensity at the vibrato oscillator frequency. The LDR varies in resistance as the light intensity varies. Capacitor #22 and the LDR are in series across the TR-2's emitter resistor and are functioning as a variable emitter bypass circuit, varying with the vibrato oscillator frequency. The gain of the TR-2 is varied because of the varying degenerative feedback.

Positive voltage for the reed bar is supplied by a conventional transformer-silicon rectifier type of power supply, consisting of T-50, R-41, R-43, R-45, R-44, R-42, and the silicon rectifier, CR-1. Positive and negative operating voltages for the amplifier are supplied through a standard bridge rectifier, CR-2, CR-3, CR-4, and CR-5.

AMPLIFIER DESCRIPTION MODEL 145 AND 720

(Vacuum Tube Amplifier)

Each of the 64 reeds in the reed bar is tuned for the specific resonant frequency at which it will vibrate when set in motion by striking a key. The pick-up plates of the reed bar are mounted near the free end of the reed, and a d.c. polarizing voltage is fed to the pick up plate through R-1. (Refer to Schematic No. 650565). As the reed vibrates back and forth through the slot in the polarized pick-up plate, a capacity change takes place at a rate corresponding to the reed's tuned frequency. This produces an alternating voltage of the same frequency or pitch.

This alternating voltage, or signal, is applied to the grid of V-1 (6K11), through the d.c. isolating capacitor C-1. The amplitude of this signal is determined by the setting of the volume control which is in shunt with the grid of V-1 (Pin 11) to ground.

The signal is then amplified in V-1 and fed through coupling capacitor C-2 to the second section of V-1, which acts as a phase splitter. Part of the output signal of this section of V-1 appears in the plate circuit and part in the cathode circuit.

These signals are of equal amplitude, however, the phase of the plate circuit differs by 180 degrees from the phase of the cathode signal. This satisfies the driving conditions for the two push-pull 7868 output tubes, V-2 and V-3.

A low frequency phase shift oscillator consisting of the third section of V-1 is used as part of the vibrato circuit. Oscillations are started by any circuit change such as plate supply ripple, or thermal agitation in the tube itself. When a disturbance occurs, the slight change is amplified and inverted 180 degrees at the plate. Since the tube normally introduces a phase shift of 180 degrees, the feedback network consisting of C-9, R-20, C-8, R-19, C-7, and R-18, provides another shift of approximately 180 degrees. Because the reactance of a capacitor varies with frequency, the combination of the three R-C sections gives a 180 degree phase shift at only one frequency. This enables the circuit to operate at only one frequency.

The output voltage of this oscillator is fed through C-6, R-17, to the vibrato control. The setting of this control determines the intensity (depth) of the vibrato oscillator signal applied to the junction of R-12 and R-13. When the vibrato control is in the extreme counter-clockwise position, the entire output of the vibrato oscillator is shunted to ground.

Amplifier Description Model 145
(Vacuum Tube Amplifier) - Cont'd.

As the control is advanced clockwise, the desired amount of vibrato (depth) is introduced as desired by the musician.

The output of the 7868 tubes, V-2 and V-3, is coupled to the speaker through the output transformer, T-2. Note the external speaker jack provided, which is in parallel with the console speaker (4 ohms.)

The fused power supply is of conventional design, using a 6CA4 rectifier tube. Filtering is accomplished by C-12 and C-15, with the various operating voltages for the entire amplifier being derived from the junctions of R-24, R-25, R-26, and R-27.

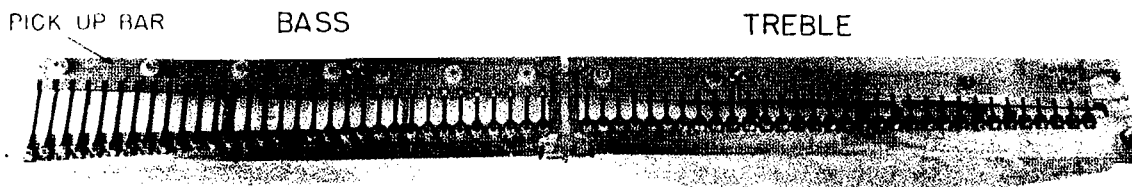

REED BARS AND REED ASSEMBLIES

The Models 720, 140, and 145 Wurlitzer Electronic Pianos utilize as a tone generator a free reed actuated by a piano hammer and damped by a damper with an action similar to a conventional piano. The musical range of the instrument is 64 notes beginning at "A", 55.000 C.P.S. and continuing through "C", 2093.005 C.P.S. On a conventional piano this would be equivalent to notes No. 13 through No. 76.

The tone pick-ups are insulated from the main bars and are mounted so the reeds vibrate through the opening when struck by the hammers. These tone pick-ups are the fixed plates of a condenser in the capacity change system. The reeds should be adjusted so the free-swinging reed clears the pick-ups but must NEVER touch them.

The pick-ups have a polarizing voltage in excess of 165 volts through a 10. megohm resistor and therefore are not a shock hazard. As the reeds swing a capacity change takes place in accordance with the tuned pitch of the reed. The change produces a varying voltage across a load resistor. The voltage is then amplified through the console amplifier, which is a completely transistorized amplifier in the Model 140, 140B, and 720B, and is a vacuum tube amplifier in the Model 145 and 720.

Please note in the photograph on the preceding page that there are two reed bars. One bar, (the one with the largest reeds) is the bar mounted on the bass end of the piano. The other bar, (the one with the smaller reeds) is mounted in the treble end of the piano. When these two reed bars are in place, the input cable to the amplifier comes off the bass end of the bass bar. The treble bar is connected to the bass bar by a piece of wire between the top end of the bass bar and the bottom end of the treble bar.

The reeds have been electrolytically coated to protect the Sandvik Swedish steel from rust or any other type of contamination or corrosion. When ordering replacement reeds always specify the model number of the piano and the note name and number. All replacement reeds are tuned slightly flat. After the reed is installed in the piano, it may be necessary to remove some of the lead from the end of the reed by scraping, to bring the reed up to proper pitch. NEVER file the steel reed -- ALWAYS add or remove lead from the tip of the reed to change the tuning.

KEY & ACTION REGULATION

Key and action regulation of the Wurlitzer Electronic Piano, like that of a conventional piano, is very important to proper functioning of the instrument. This regulation should only be performed by a competent piano tuner-technician or a trained serviceman.

A WORD ABOUT THE ACTION

The action of the Wurlitzer Electronic Piano functions in the same manner as the action of a conventional piano, and by studying the schematic drawing of the action (No. 650552) this will be immediately apparent.

As the key is depressed, its motion is transmitted through the whip and fly to the butt knuckle and moves the hammer toward the reed. When the hammer has reached a point 1/8" from the reed, the heel of the fly contacts the head of the regulating screw and the fly escapes, allowing the hammer to free-travel to the reed, strike the reed, and set it in vibration. The hammer then rebounds down from the reed, and its motion is checked by the interaction of the wedge surface near the tip of the fly and the mating surface of the butt.

When the hammer has begun moving toward the reed, the damper is lifted from the reed.

When the key is released, the action returns to the normal, or rest, position.

PREPARATION OF THE PIANO FOR SERVICING

The top assembly of the piano must be removed for complete access to the keys and action. Begin by removing all screws which fasten the top assembly to the case, and lift the top straight up until the drop rail clears the sides of the case. The top assembly is still attached to the piano by the electric cable from the controls on the front panel.

Next, raise the treble end of the top assembly until it is approximately vertical, turn it around, and lower the treble end of the top assembly to the floor.

NOTE: In later production instruments, the controls were moved from the top to the key block on the bass end of the piano. This will allow complete removal of the top.

REGULATING PROCEDURE

In the keys and action of the Wurlitzer Electronic Piano, there are approximately 3,200 parts made mostly of wood, metal and felt. These materials are specially selected and manufactured for use in piano keys and actions, but the normal wear from playing the piano, packing of the felts, and changing atmospheric conditions will probably necessitate some re-regulation of the instrument.

The following pages outline the procedure for complete regulation of the Wurlitzer Electronic Piano. Before proceeding with a complete regulation, however, the instrument should be analyzed to determine the extent that regulation is required.

1. KEYBOARD INSPECTION

First, check the felt punchings on both the balance and front pin lines and the felt on the keybed at the back of the keys, replacing these felts if they are moth-eaten or packed excessively.

Next, inspect the entire keyboard for free movement of each key at both the balance and front pin lines. When the fronts of the keys are raised approximately 1/4", they should fall without hesitation.

2. EASE KEYS

When a piano keyboard is found to be sticking or sluggish, the cause is often due to the felt swelling either at the balance key bushing or at the front key bushing, or both. Even if just one or two keys are sticking, it is advisable to check the entire keyboard. The easing is done by using a pair of easing pliers which can be obtained from any reputable tuners' supply house.

Easing is executed by inserting one lip of the pliers into the opening in the key and positioning the other lip of the pliers on

the outside of the key, and squeezing firmly but carefully. Wood and felt are thereby compressed to obtain a proper clearance at the pin.

When easing keys, caution should be exercised so keys are not overeased. Overeased balance pin bushings will cause the keys to tip, and overeased front pin bushings will cause excessive side play, and in extreme cases, adjacent keys touching at the fronts. Overeased keys will not stay properly spaced.

If severe wear or packing of the key bushing felts has occurred, it may be necessary to rebush the keys.

Sometimes sticking keys may be due to the hole at the bottom of the key (at balance point) swelling and tightening around the pin. A reamer may be used at this point to enlarge the hole and insure proper clearance. However, the clearance should not be excessive. The key should drop freely over the pin, but not have excessive play.

3. INSPECT ACTION FOR FREE CENTERS

First check the butt centers by raising the butts from the hammer-regulating rail and allowing them to fall abruptly, observing the movement of the butts. If the butt centers are free, the butts will fall back to the rail without any hesitation.

Whip centers are checked by depressing the full sustaining pedal to remove all damper spring tension from the whip assembly. Fully depress each key and release it slowly. If the key does not completely return, or if it returns very slowly, the whip centers probably are sluggish. Keys must, of course, be properly eased before this inspection is performed.

If the action centers are sluggish they must be shrunk according to the procedure which follows.

4. SHRINKING ACTION CENTERS

If the action centers become sluggish due to excessive moisture, they must be shrunk to restore the proper amount of freedom. If shrinking is necessary, all butt and whip flange centers should be treated.

The shrinking solution consists of eight (8) parts of V. M. & P. Naptha and one (1) part of light mineral oil. V. M. & P. Naptha can be purchased at most paint stores.

Apply a few drops at each center so it will soak into the bushing cloth. The response to the shrink solution should be immediately apparent. Caution should be used when applying. Key caps can be damaged.

NOTE: Shrinking solution should be applied before regulation for best results.

5. INSPECT ACTION

- A. Tighten all screws of the action.
- B. Check the damper levers for squeaks, and apply graphite to the spring punching to eliminate any squeak which may occur. Punching located under damper lever clip.
- C. Check the action completely for any broken parts, loose flanges, moth-eaten or loose felts, etc., and repair or replace as necessary.
- D. Reface the hammers if necessary.

6. SET KEY HEIGHT

The proper key height is 2" measured from the keybed to the underside of the projecting lip on the front of the natural keys. The key height is adjusted by adding or removing hard paper shims between the balance rail of the keyframe and the keybed.

7. SQUARE AND LEVEL

When the keys have been set to the proper height, the keys are squared to a straightedge by lightly tapping the tops of the balance rail pins toward the bass or treble as required.

The keys are leveled to the proper height above the keybed. The sharp keys are then leveled to the natural keys so the plastic surface on the back of the sharp cap is even with, or very slightly below, the corresponding surface of the natural key.

8. SPACE KEYS

Keys are spaced by bending the front rail pin toward the bass or treble as necessary with a forked key spacing tool.

The natural keys are adjusted so the spaces between the keys are uniform. The sharp keys are then spaced so they are centered between the adjacent natural keys.

As the keys are spaced, "brush" forward on the keys with the palm of the hand so the keys fall in their natural position. A WORD OF CAUTION: After keys are spaced, check the backs of the keys to make certain adjacent keys are not touching each other. It may be necessary to sand some keys slightly to insure the proper clearance between keys.

9. REMOVING ACTION PARTS

It is not necessary to remove the action from the piano to replace parts of the action. The individual assemblies can be replaced as

described below:

A. Butt Assembly

Disconnect the damper regulating screw from the damper lever by pulling the grommet out of the wire clip. Remove the butt flange screw, rotate the butt approximately one-quarter turn, and pull the butt assembly out between the top of the main rail and the damper rail.

B. Damper Lever Assembly

Disconnect the damper regulating screw from the damper lever by pulling the grommet out of the wire clip. Remove the damper flange screw and lift the damper lever up and out of the action.

C. Whip Assembly

The Wurlitzer Electronic Piano has a Whip Stop, shown in Figure "1", which prevents the fly dropping out of the butt knuckle when the keys are removed. The Whip Stop is secured by three screws, one at each end and one in the center. Remove the keys, loosen these three screws, and remove the Whip Stop. Disconnect the damper regulating screw from the damper lever by pulling the grommet out of the wire clip. Remove the whip flange screw and slide the whip out toward the front of the case. After replacing the whips the Whip Stop must be correctly adjusted. The Whip

FIGURE 1 - PROPER ADJUSTMENT OF WHIP STOP

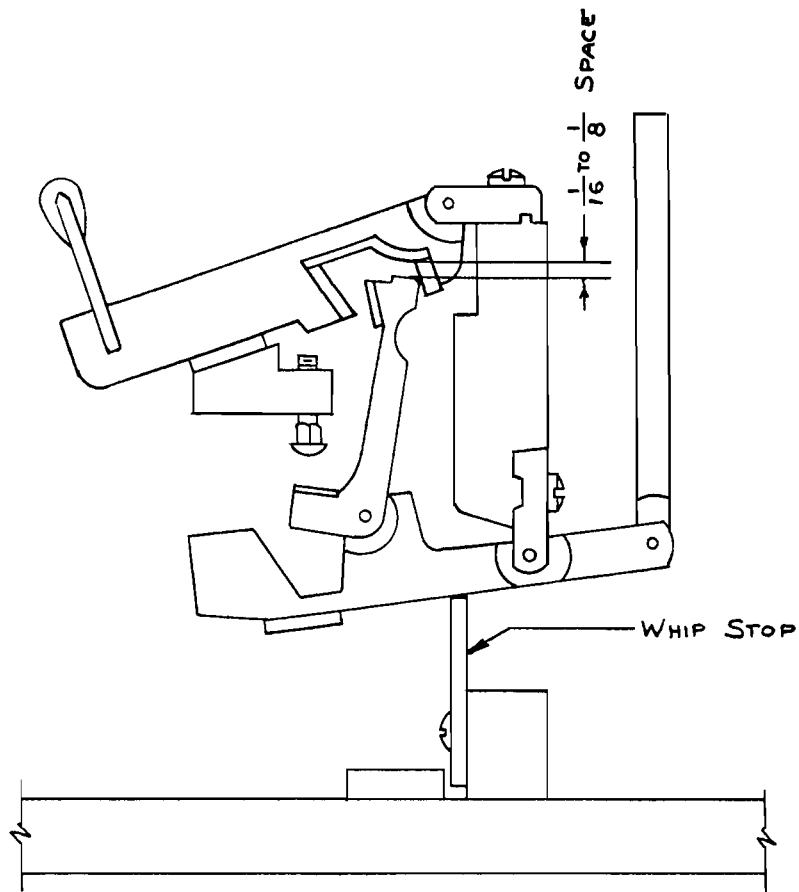

Stop is set so there is a gap of 1/16" to 1/8" between the tip of the fly and the butt knuckle with the whips resting on the Whip Stop, as shown in Figure "1". Only after the Whip Stop is adjusted are the keys replaced.

10. STRIKING POINT

The striking point of the hammers to the reed bar is very important, just as it is in a conventional piano. The striking point is properly set at the factory and should require little or no adjustment in the field.

In the event the striking point does need adjustment, it is most likely to occur in the extreme treble. Loosen the two screws which attach the reed bar to the treble end of the case and the stop screw at the treble end of the reed bar, and turn the instrument "on". While striking the treble keys, move the treble end of the reed bar slightly forward and backward until the maximum volume and desired tone is reached.

Tighten the stop screw at the front side of the treble end of the reed bar, and the two screws which fasten the reed bar to the case.

The striking point of each of the reeds is 1 11/16" measured from the front edge of the reed bar to the point where the hammer contacts the reed.

If there are only one or two treble notes that do not sound right because of improper striking point, the hammers can be burned either forward or back by applying heat with a soldering iron to the shank or moulding of the hammer and at the same time forcing the hammer in the desired direction.

11. HAMMER BLOW DISTANCE

The hammer blow distance is factory-set and normally will not require adjustment.

The correct blow distance is approximately 1 1/8" measured from the tip of the hammer to the under surface of the reed.

12. ADJUST LOST MOTION

Lost motion is adjusted by turning the capstan screw up or down in the back of the keys. When lost motion is correctly adjusted the hammers will move immediately as the keys are depressed, and will rest on the hammer rail without any downward movement when pushing down hard on the backs of the keys.

13. ADJUST LET-OFF

The hammer let-off (fly escapement) is adjusted by turning the capstan-type regulating screw up or down in the hammer-regulating rail. The hammer should let off when it is 1/8" from the reed.

FIGURE 2 - HAMMER CHECK-BACK

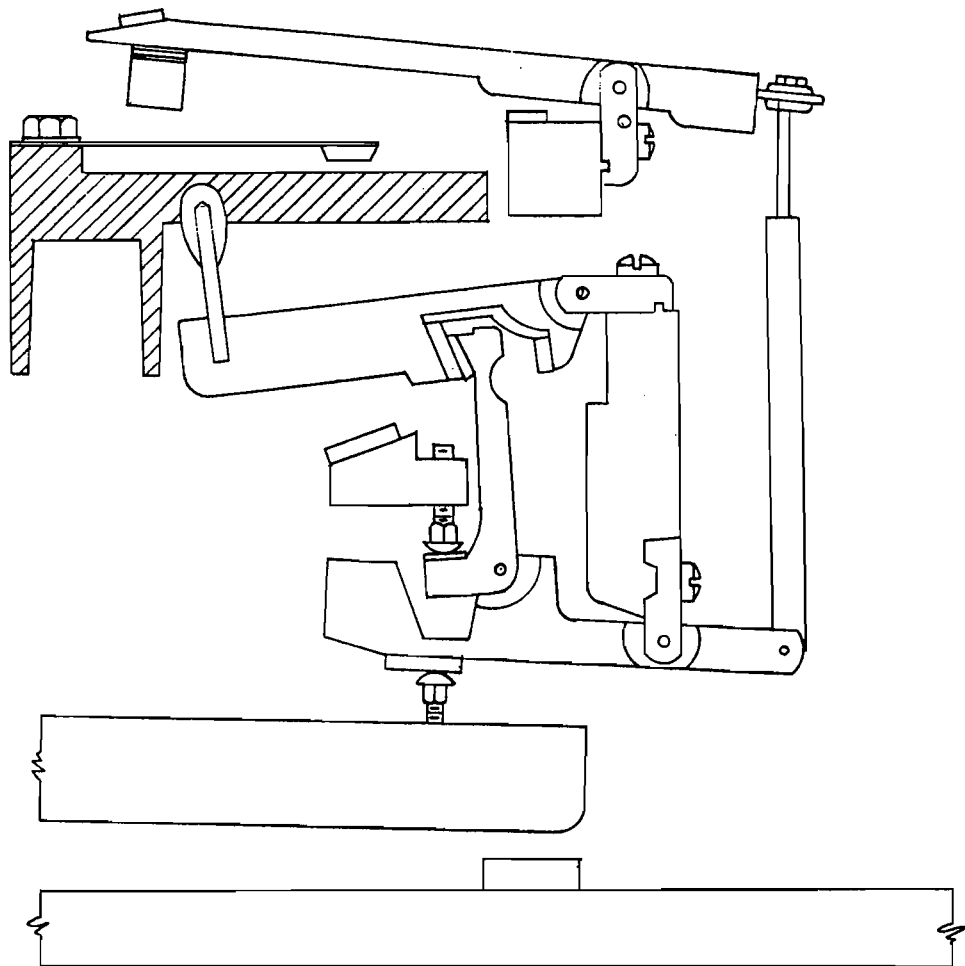

14. HAMMER CHECK-BACK

The hammer check-back is accomplished by the wedge-shaped surface near the tip of the fly and the mating surface of the butt.

The hammer check-back will be correctly adjusted when the "Touch Laying" operation is performed.

15. TOUCH LAYING

The touch lay operation consists of establishing the proper key dip, or movement of the front of the keys, for the instrument.

The key dip, measured at the front of the natural keys, should be approximately 3/8". This measurement will vary slightly depending upon the accuracy of the preceding regulation which has been performed.

Touch is layed by adding or removing paper punchings beneath the felt punchings on the front rail pins.

It is very important that the proper amount of after touch is maintained during regulation of the action. If too little after touch is obtained, the hammer will tend to "bobble" and may double strike the reed. If there is too much after touch, this additional movement of the key will cause the hammer to raise up toward the reed after checking and may cause it to block on the reed.

The correct amount of after touch can be checked by striking the key with a light, medium, and hard blow, and observing the check-back of the hammer. When properly regulated, the hammer will check back essentially the same distance from the reed regardless of the type of blow struck.

In regulating the after touch, begin by regulating keys Nos. 3, 30, 35, and 63, as described in the preceding paragraph. These keys become the "setters" for regulating the piano. Starting at the bass end of the keyboard, strike three (3) adjacent keys with a medium blow and observe the check-back of the hammers. The three (3) hammers should check back an equal distance from the reeds. If necessary, add paper punchings beneath the felt front rail punching to obtain equal hammer check back. Repeat this procedure for the entire keyboard.

Proper touch laying provides about 1/32" after touch, or downward movement of the key after fly escapement occurs. This after touch is necessary to "lock" the butt in the check-back position as shown in Figure "2".

16. DAMPER SUSTAIN ADJUSTMENT

The nut on the bottom of the Damper Connecting Rod, shown on the Piano Action Schematic, Drawing No. 650552, is a stop to limit the

upward movement of the damper connecting rod. This nut should be adjusted so that a space of approximately 1/32" exists between the bottom of the damper levers and the felt on the damper rail. This will insure proper damping of the reeds.

The following conditions are characteristic of an improperly adjusted damper connecting rod nut:

A. Nut Too Low

If the nut is set too low, a greater space remains between the damper rail and damper lever, and as the sustaining pedal is depressed to rotate the damper rail, all of the dampers may not lift off the reeds. This results in a "dull" tone of extremely short duration.

B. Nut Too High

When the nut is adjusted too high, there will be insufficient space between the damper rail and the damper levers, and some of the dampers may be held off the reeds. This results in failure to dampen some reeds.

The adjustment of the damper connecting rod nut must be performed before proceeding with the regulation of the individual dampers.

17. DAMPER LEVELING

When the damper connecting rod nut has been properly adjusted, the

FIGURE 3 - PEDAL BRACKET ASSEMBLY

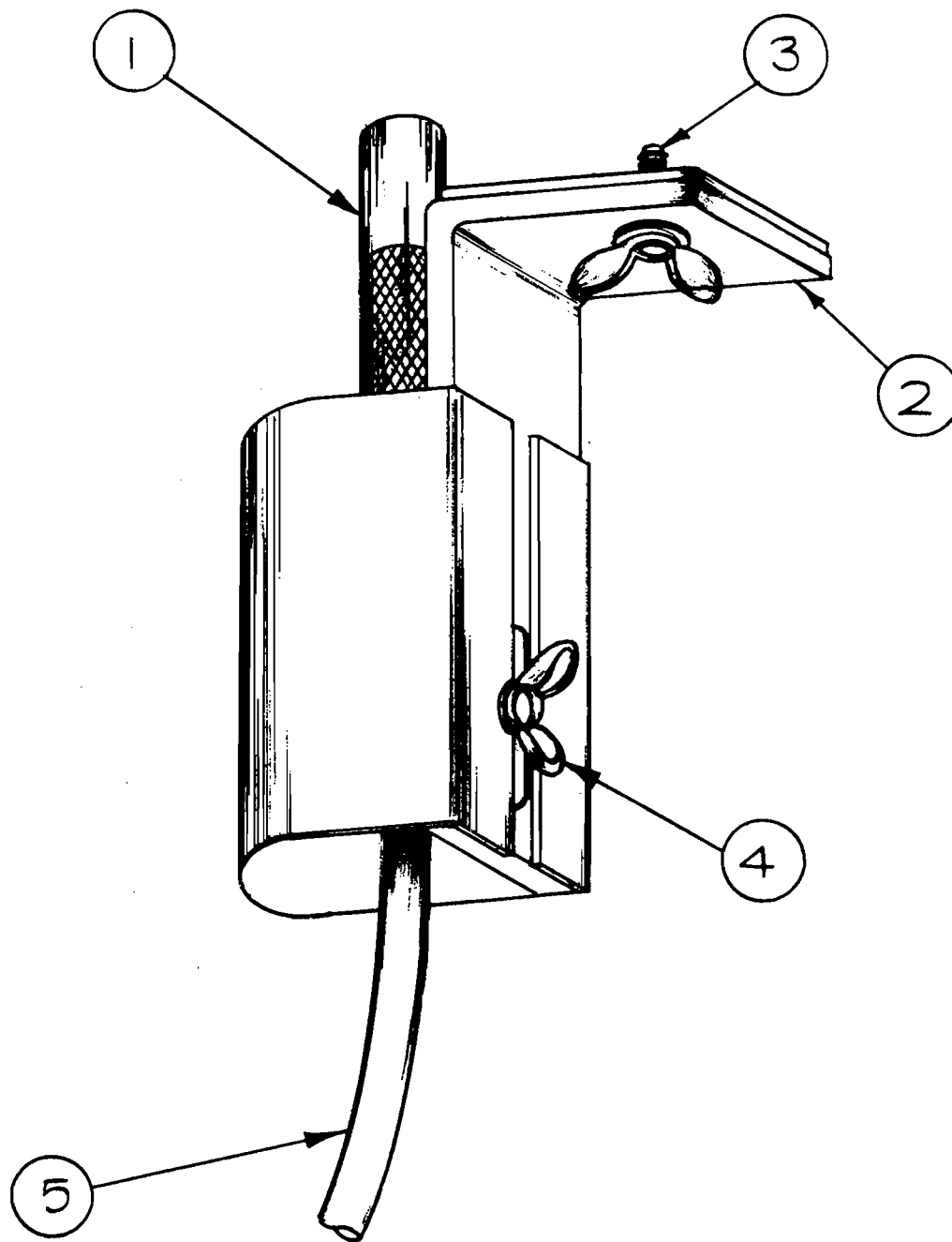

dampers themselves should be inspected for uniform lift.

Depress the full sustaining pedal and observe the lift of the dampers. If some of the dampers are "slow", that is, they lift off the reeds somewhat later than the majority of the dampers, they must be adjusted by gluing a thin paper shim on the bottom surface of the damper lever where it contacts the felt on the top of the damper rail.

The shim compensates for uneven wear or packing of the damper rail felt and provides a uniform damper lift.

18. DAMPER REGULATION

The dampers are adjusted by turning the damper regulating screws which pass through the neoprene grommets at the back of the damper levers. The dampers are properly regulated when a gap of approximately .035" exists between the top of the grommet and the bottom of the screw head.

When regulating the dampers, use a .035" gauge between the grommet and screw. The damper regulating screw has a slotted hexagonal head, and either a screwdriver or a socket tool (nut runner) may be used to adjust this screw.

SCHEMATIC - AMPLIFIER - MODEL 145 E.P.

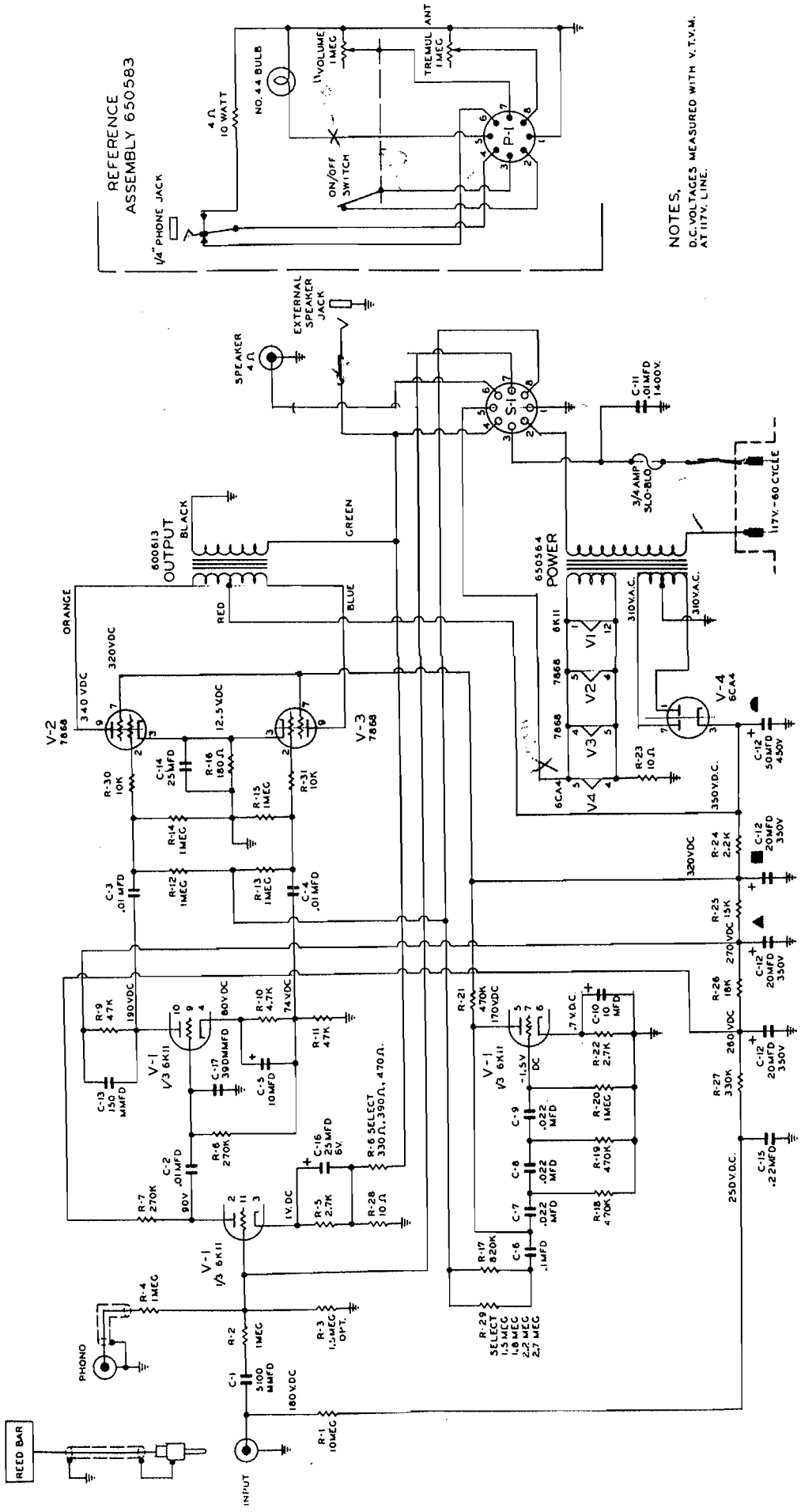

REFERENCE
ASSEMBLY 650583

NOTES,
D.C. VOLTAGES MEASURED WITH V.T.V.M.
AT 117V. LINE.

THE WURLITZER COMPANY - DEKALB DIVISION - DEKALB, ILLINOIS
MODEL - 145 ELECTRONIC PIANO
TITLE - AMPLIFIER
PART NO. 650565-S-3-E-17
ISSUE 3-DATE-APRIL 13, 1965
STARTING SERIAL NO. 30177

RESOLDER TO

REPLACE 650565 WITH TRANSFORMER AT PT

REMOVE NEON BULB - COMPLETELY REMOVE BULB AS FOLLOWS

NEON BULB - REMOVE

SCHEMATIC - ELECTRONIC PIANO - MODEL 140B / 720B

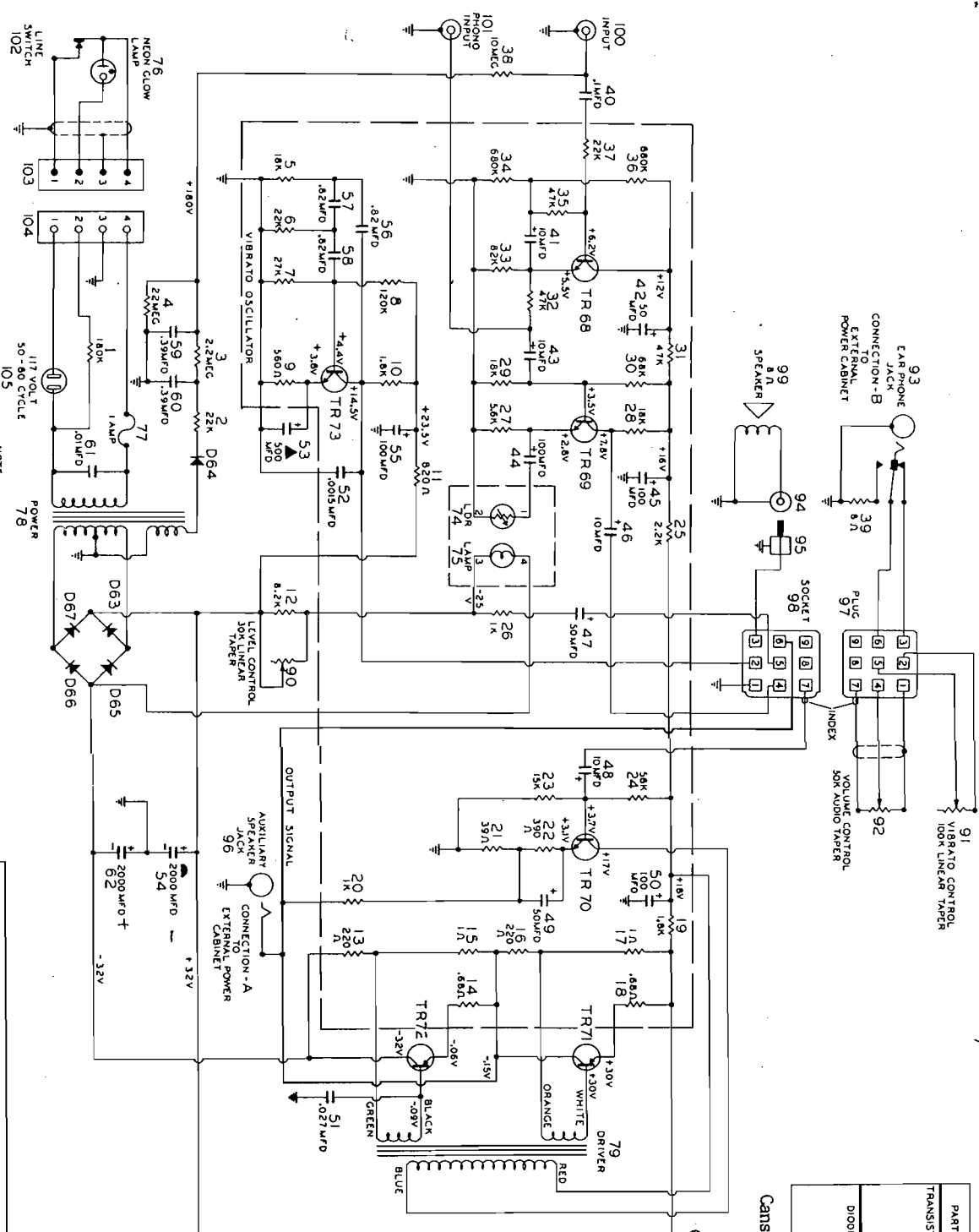

NOTE:
COMPONENTS SHOWN WITHIN
BROKEN LINE BORDERS ARE
MOUNTED ON PRINTED CIRCUIT
BOARD.

PART NUMBER	WURLITZER PART NUMBER
TR68	11-0422
TR69	11-0422
TR70	11-0422
TR71	11-0398
TR72	11-0398
TR73	11-0423
D63	11-0428
D64	11-0430
D65	11-0429
D66	11-0429
D67	11-0429

Cans. C 54 11-0397 sub: 74995 neg. can
2000/35V.
500/6V.

Can. C-62 11-0396 sub: 74801 2000/35

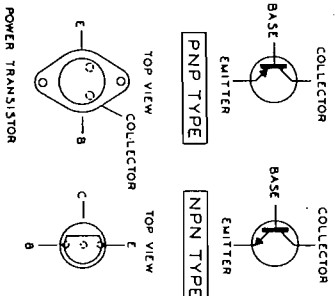

NOTE:
ALL DC VOLTAGES MEASURED WITH A
VACUUM TUBE VOLTMETER TO CHASSIS GROUND
TOLERANCE ±10% EXCEPT AS NOTED.
LINE VOLTAGE 117 VOLTS.

ALL ELECTRONIC COMPONENTS SUCH AS
RESISTORS, CAPACITORS ETC ARE IDENTIFIED
WITH A NUMBER.
THE 41 IS THE
IDENTIFICATION NUMBER

THE WURLITZER COMPANY - DEKALB DIVISION - DEKALB, ILLINOIS
MODEL - 140B ELECTRONIC PIANO
TITLE - SCHEMATIC - ELECTRONIC PIANO - PART NO. 11-0547-S-4-E-1
STARTING SERIAL NO. 29091
DATE - JUNE 1, 1966

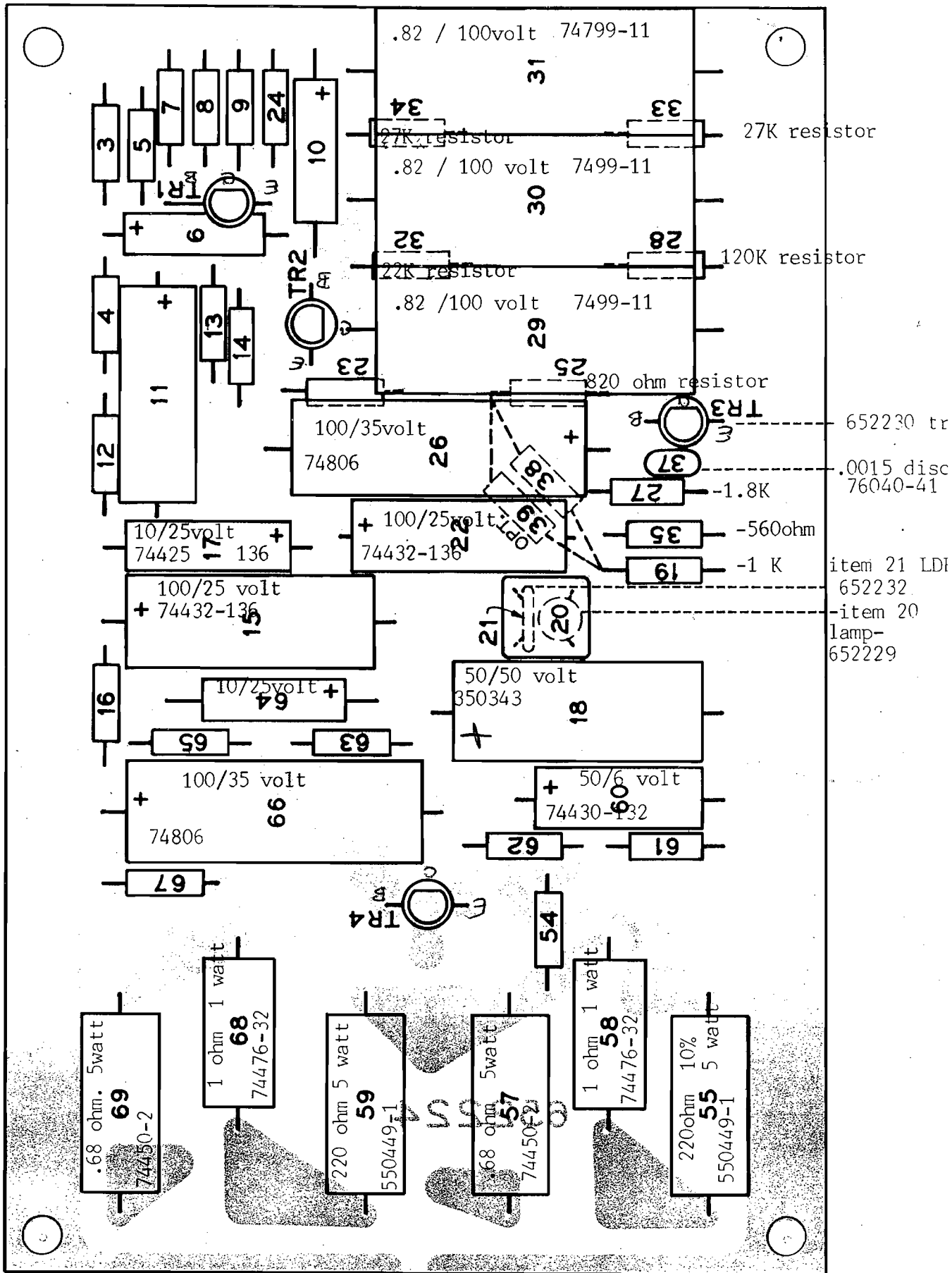

MODEL - 140-B ELECTRONIC PIANO PART NO. - 652233-S-1-E-5
 TITLE - P.C. BOARD AMPLIFIER
 STARTING SERIAL NO. - 27501 DATE - 3/1/74
 THE WURLITZER COMPANY - DEKALB DIVISION - DEKALB, ILL.

WURLITZER ELECTRONIC PIANO MODEL 140

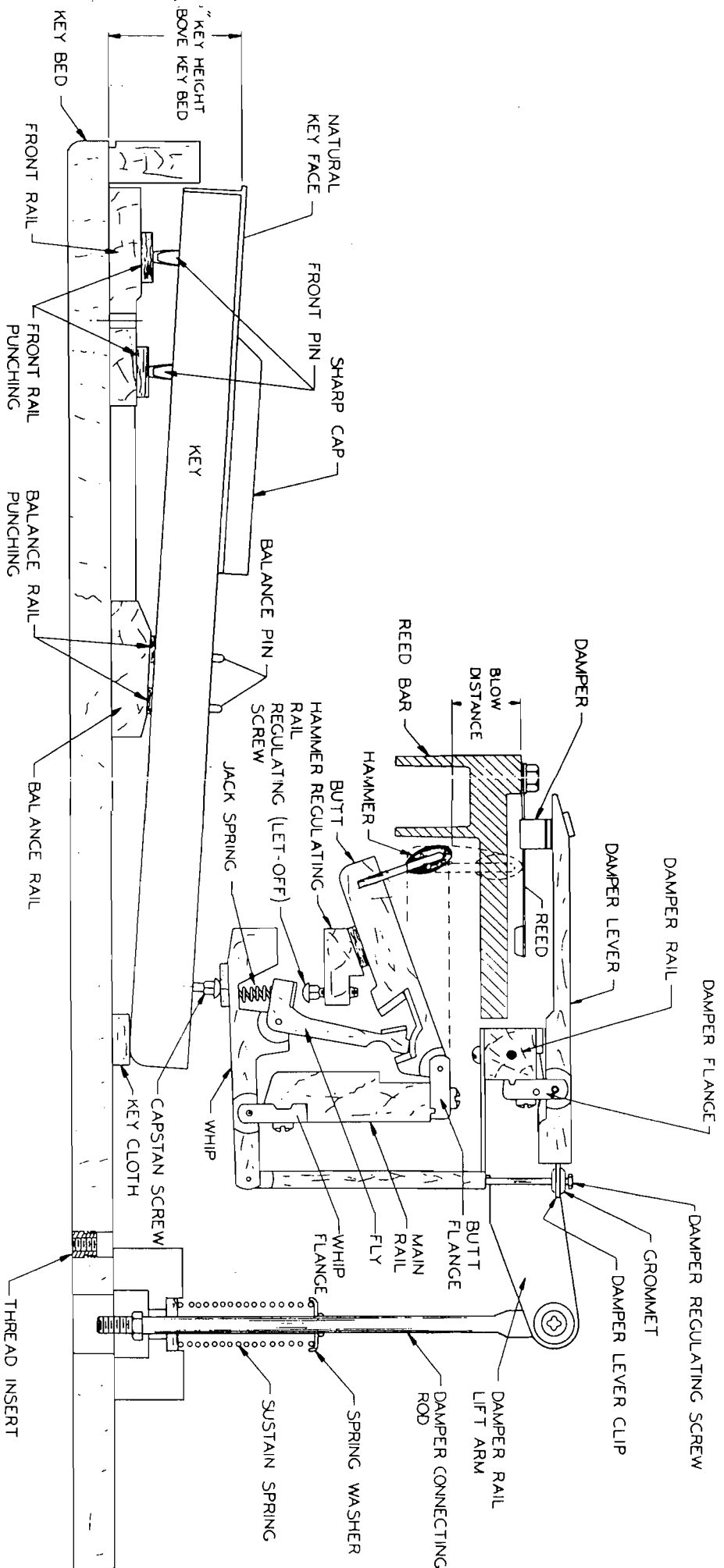

THE WURLITZER COMPANY DEKALB DIVISION - DEKALB, ILLINOIS
MODEL 140 ELECTRONIC PIANO
 TITLE PIANO ACTION SCHEMATIC PART No. 650552
 STARTING SERIAL No. 25001 ISSUE 1 DATE 4/1/62