

# **MODEL 112**

## **WURLITZER ELECTRONIC PIANO SERVICE MANUAL**

# WURLITZER ELECTRONIC PIANO SERVICE MANUAL

## Introduction

Developments in the fast-moving world of electronics, together with constant research and engineering in the Wurlitzer laboratories, have made possible a number of improvements and refinements in Wurlitzer Electronic Piano design and construction since the introduction of this sensational instrument in 1954. We are pleased to present herewith a new Wurlitzer Electronic Piano service manual incorporating the many new ideas and design refinements that have been made. The new, loose-leaf format is designed for the convenient addition of new material as it becomes available.

The Wurlitzer Electronic Piano is an entirely new concept in the field of keyboard musical instruments. In many ways, the Wurlitzer Electronic Piano is very similar to the conventional piano. And, in many ways, it is quite different.

It should be stated at this point that the Wurlitzer Electronic Piano is a piano with a "purpose." Not only has it been designed to be sold on its own merits in scores of specialized markets where conventional pianos would not be appropriate, but it can and will become an important factor in increasing the sale of standard, 88-note pianos through lesson and rental promotional programs.

As you will discover, the instrument is extremely simple. This manual, which describes and discusses the basic operating principles of the Wurlitzer Electronic Piano, is intended only to serve as a guide in the servicing of the piano. It is not intended as a piano service course in "ten easy lessons."

We invite and encourage you to direct any inquiries not answered in this manual to our Service Department. We look forward to the opportunity of being of service to you.

Service Department  
The Rudolph Wurlitzer Company  
Corinth, Mississippi

## PREPARATION OF THE WURLITZER ELECTRONIC PIANO FOR SALE

Extreme caution and precision methods have been used in the manufacturing, testing, and packing of the Wurlitzer Electronic Piano. However, damage in shipment occasionally occurs, and the instrument should be thoroughly checked before it is placed in use.

- (1) Unpack carefully; examine for in-transit damage. (For handling of damage claims, see Wurlitzer Piano Service Manual.)
- (2) Check amplification system.
- (3) Check key and action regulation.
- (4) Dust and clean instrument thoroughly; set up and test auxiliary equipment.

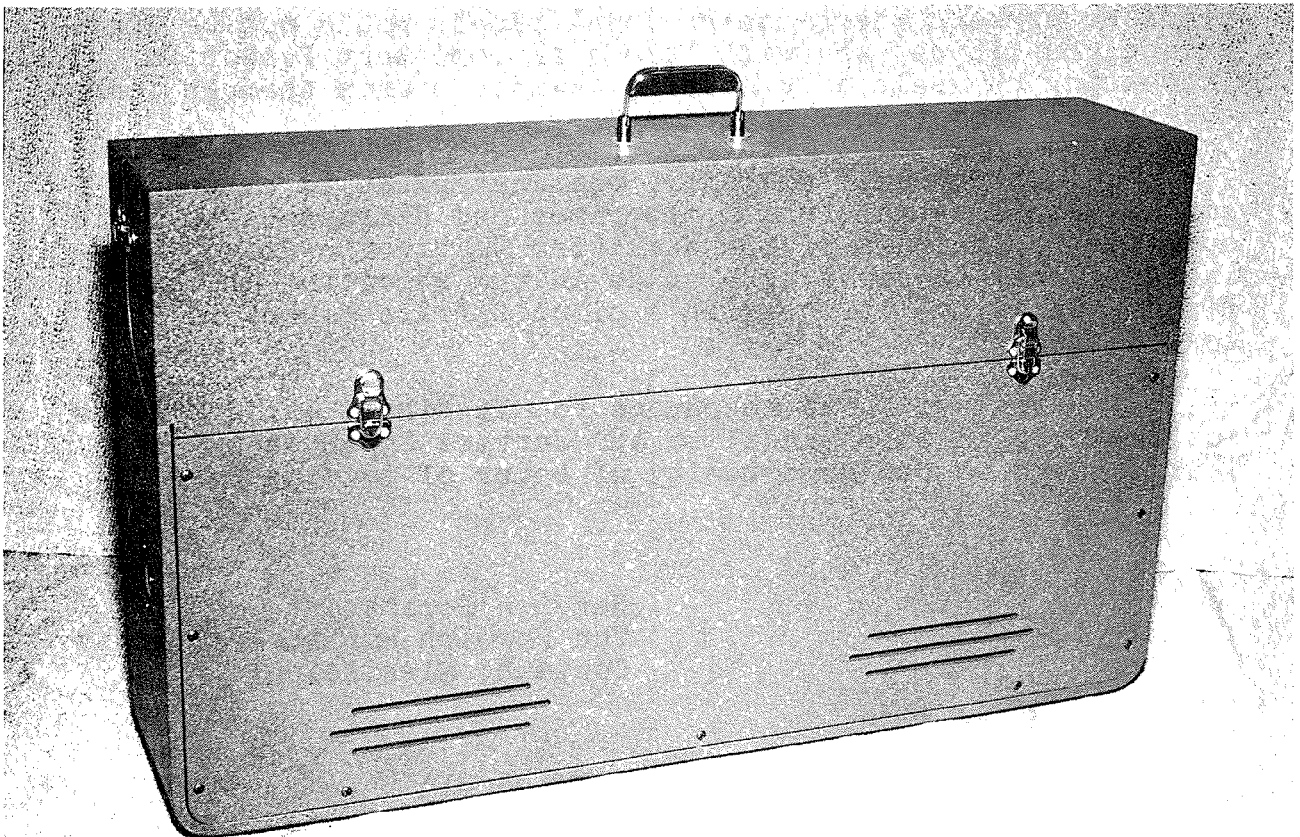



---

SPECIFICATIONS FOR WURLITZER ELECTRONIC PIANO MODEL 112

Width	-	39 <sup>00</sup>	110 Volts, AC
Depth	-	22 1/4 <sup>00</sup>	60 Cycle
Height	-	8 1/4 <sup>00</sup>	AC Wattage Consumption: 60

---

SPECIFICATIONS FOR BENCH FOR WURLITZER ELECTRONIC PIANO  
MODEL 112

---

Height	-	19 1/4 <sup>00</sup>
Width	-	13 <sup>00</sup>
Length	-	22 <sup>00</sup>

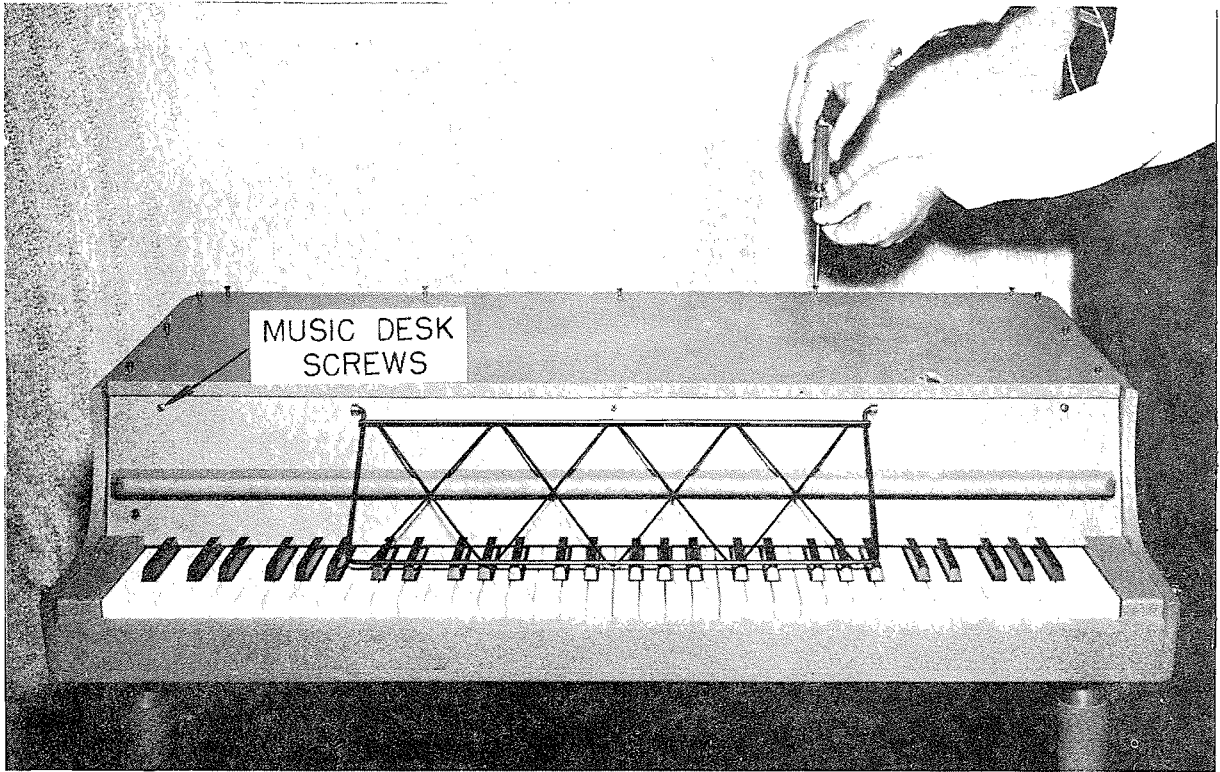

Fig. 1

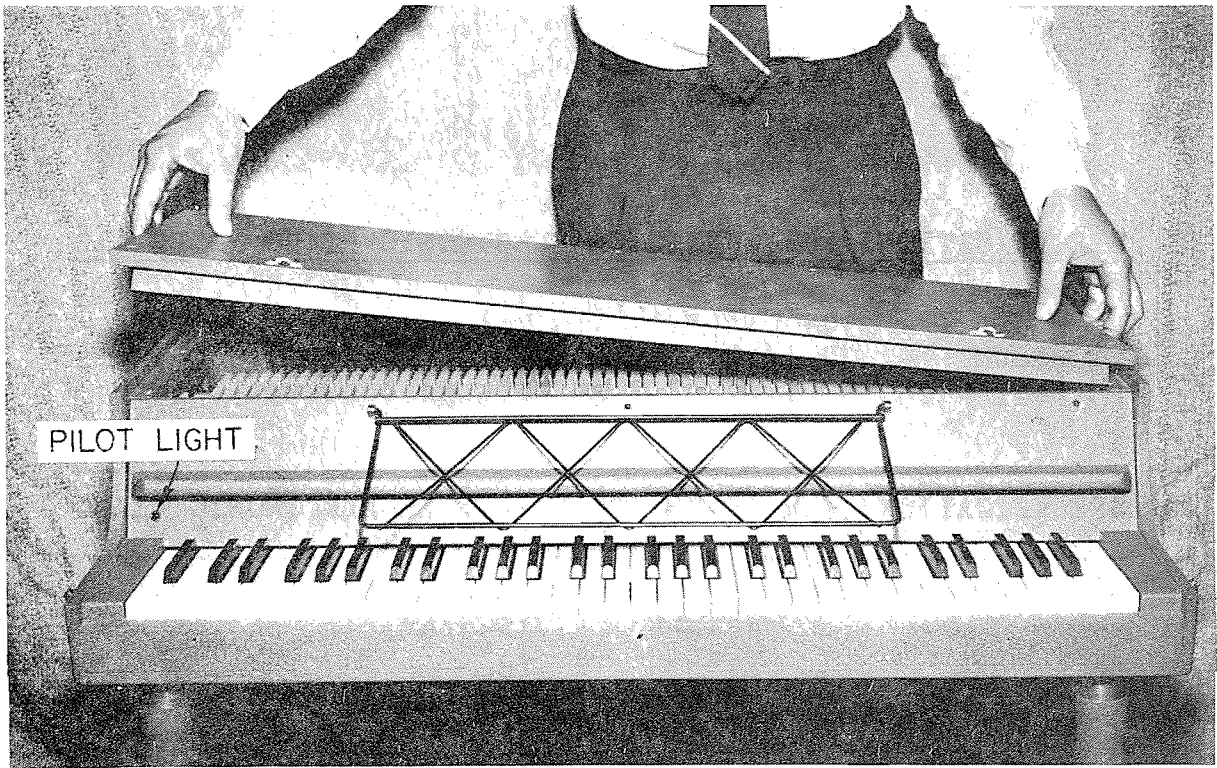

Fig. 2



## CHECKING THE AMPLIFICATION SYSTEM

1. Remove fall cover assembly (keycover) by releasing catches.
2. Remove screws from top as shown in Fig. 1.
3. Remove screws from music desk as shown in Fig. 1.
4. Lift top completely off piano as shown in Fig. 2.
5. Inspect the amplifier to see if all tubes are mounted securely in their sockets. These tubes are not special tubes and can be obtained easily in your own locality. (Location of tubes shown in Figs. 3 and 10 and on Schematic Diagram, Fig. 9.)

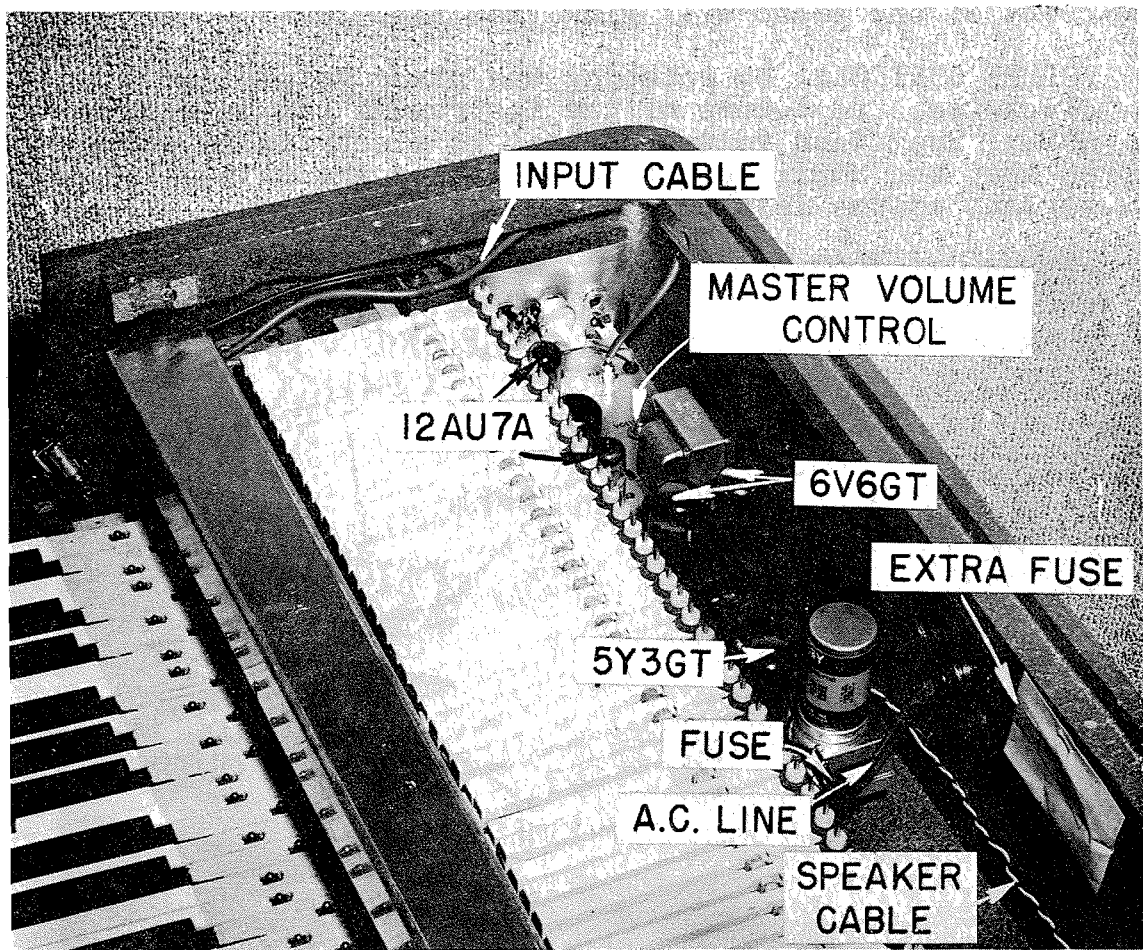

Fig. 3

6. Check to see if the following cables are plugged in tightly, as shown in Fig. 3:
  - (a) Piano input cable
  - (b) Piano speaker cable
7. FUSES: Check 1 amp fuse (Slo-Blo) as shown in Fig. 3 and Fig. 10.
8. AC CORD: This cord comes packed separately and is a one piece moulded line cord that fits the receptacle shown in Fig. 4.

WARNING - THIS INSTRUMENT OPERATES ONLY ON 110 VOLTS,  
60 CYCLE.

9. SWITCH: The line switch is on the piano volume control and its "off" position is clearly indicated on the unit and also in Fig. 4. As the piano volume control is rotated clockwise, the switch will click and the pilot light on the front of the piano will glow (See Fig. 2).
10. VOLUME CONTROL: By rotating the piano volume control clockwise, the volume of the instrument can be regulated.  
NOTE: The piano volume control is electrically designed so that the amplifier characteristics are maintained at various volume levels.

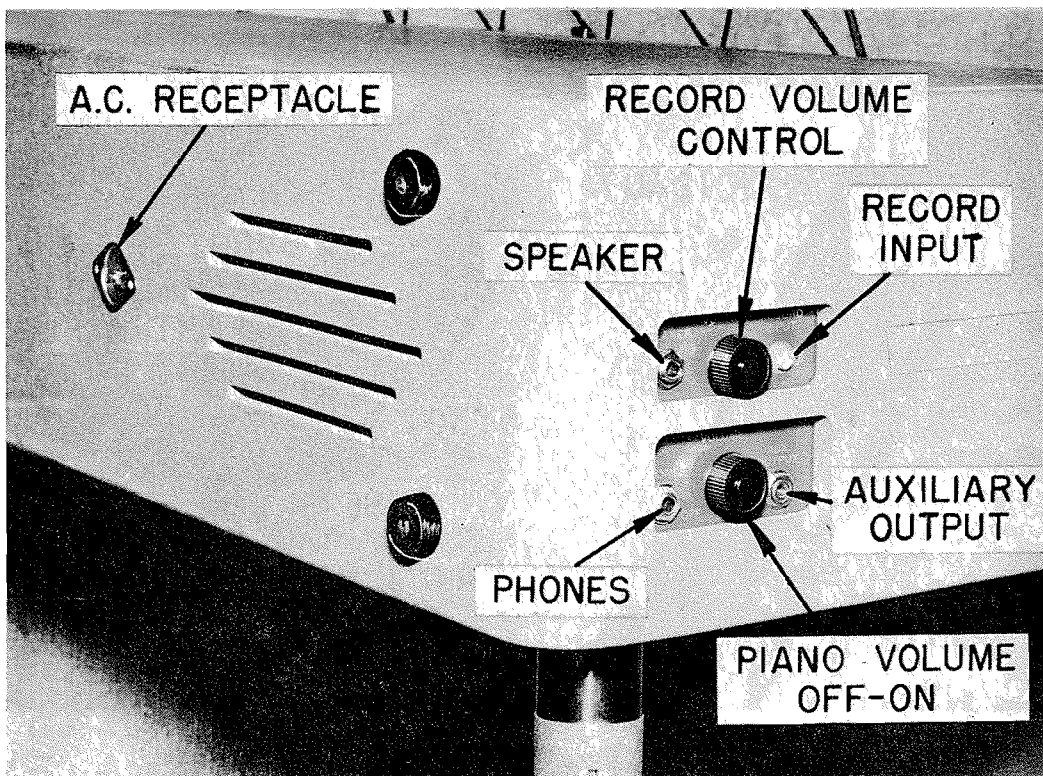

Fig. 4





NOMENCLATURE

- |                        |                     |                           |
|------------------------|---------------------|---------------------------|
| 1. Front Rail Pin      | 19. Pick-Up Washer  | 28. Damper Lever Flange   |
| 2. Key                 | 20. Pick-Up Screw   | 29. Damper Lever Spring   |
| 3. Music Desk Assembly | 21. Pick-Up Bushing | 30. Damper Washer         |
| 4. Balance Key Pin     | 22. Reed Washer     | 31. Damper Let-Off Button |
| 5. Key Cloth           | 23. Damper Rod      | 32. Main Rail Stiffener   |
| 6. Capstan Screw       | 24. Shield          | 33. Damper Lever Wire     |
| 7. Whip Flange         | 25. Pick-Up         | 34. Amplifier             |
| 8. Fly (or jack)       | 26. Damper          | 35. Speaker               |
| 9. Main Rail           | 27. Reed Screw      |                           |

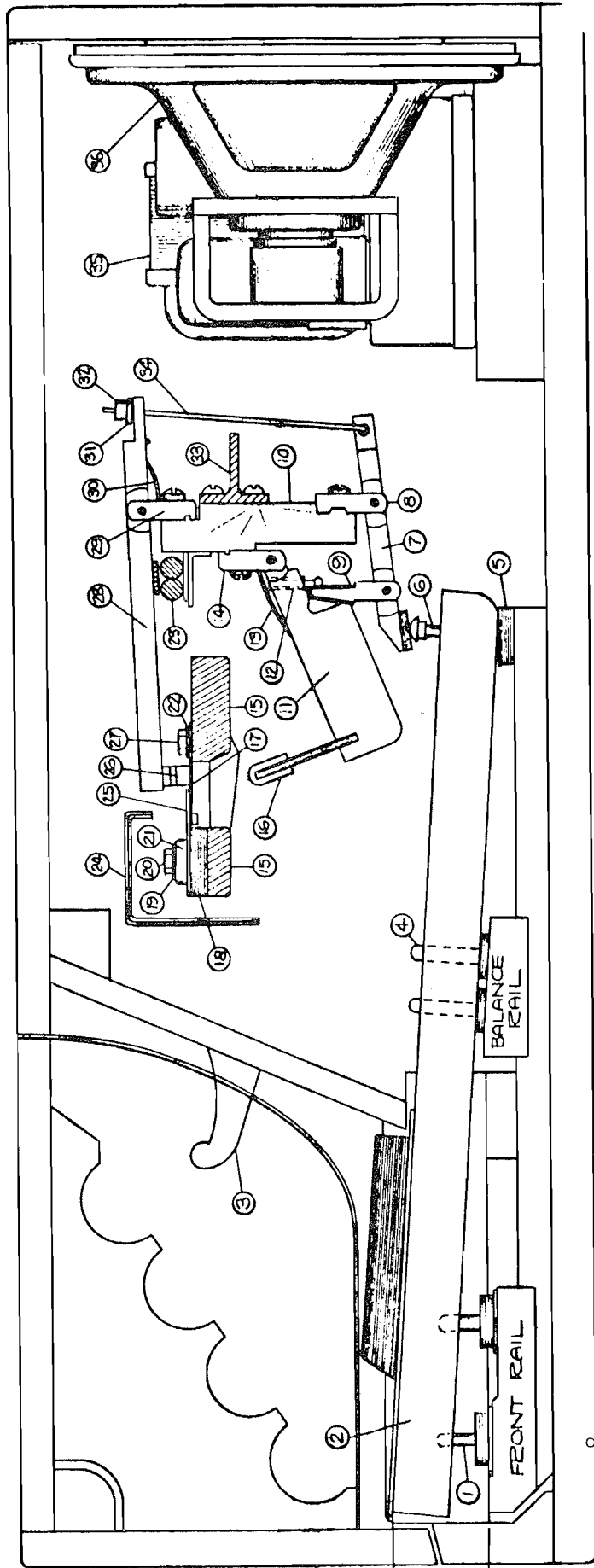

WURLITZER ELECTRONIC PIANO MODEL 112  
(U.S. AND FOREIGN PATENTS PENDING)

Fig. 6

## KEY AND ACTION REGULATION

Like the conventional piano, the regulation of the keys and action on the Wurlitzer Electronic Piano is very important. Key and action regulation on the Wurlitzer Electronic Piano requires the services of a competent piano tuner-technician. Being a simplified action, the regulation differs somewhat from a conventional piano; however, the principles are essentially the same.

When checking for the proper condition of an action, the action should be examined for tight or loose centers, and the keyboard should be checked for free movement of all the keys at both the balance and the front pin line. Should a sluggish condition prevail due to excessive moisture in the atmosphere, determine whether the sluggishness is the keys or the action and follow the instructions under the sections devoted to "Easing Keys" and "Shrinking Action Centers" found in the Wurlitzer Piano Service Manual.

### EASE KEYS

Refer to Wurlitzer Piano Service Manual, Page 4.

### CAPSTAN ADJUSTMENT

This is covered under the following section devoted to "Touch".

### TOUCH

Determine if the key depth is satisfactory to the present setting of the key height. These heights are: Natural- $3/8$ " measured at face of key. Sharps- $5/16$ " measured over pin.

If the key depth is not right, check the section under "Level Keys" first (page 11). BE SURE THE KEY HEIGHT IS CORRECT. If the key height is correct and the key depth is shallow it may be increased by removing material from the bottom of the front of the key. If the key depth is too deep paper punchings of the required thickness may be glued to the bottom surface of the front of the key.

The capstan screw (No. 6, Fig. 6) (Fig. 7) should then be adjusted so that when the back of the key is pressed down the hammer butt (No. 11, Fig. 6) will move downward approximately  $1/32$ ". Be sure the capstan screw is not turned down to a point where lost motion occurs. The key should then be pressed down and the let-off point may be determined by adjusting the regulating screw (No. 12, Fig. 6).



## TOUCH (Continued)

The hammer should let off  $1/16''$  from the reed and just before the key bottoms. This allows less than  $1/64''$  after touch or movement of the key after the let-off. If the regulating screw (No. 12, Fig. 6) is turned clockwise too far, it will cause the hammer to let off too soon and excessive after-touch will occur. If the regulating screw is turned counter-clockwise too far, the hammer will not let off and will cause blocking of the reed.

If the hammer lets off too far from the reed, check the setting of the capstan screw for lost motion. Also check the key depth. If the hammer let-off is still too far from the reed, the key depth should be increased as required. If the hammer lets off too close to the reed, it will cause blocking. For correction first check the capstan setting and key depth. If the hammer still lets off too close to the reed, the key depth should be decreased as required.

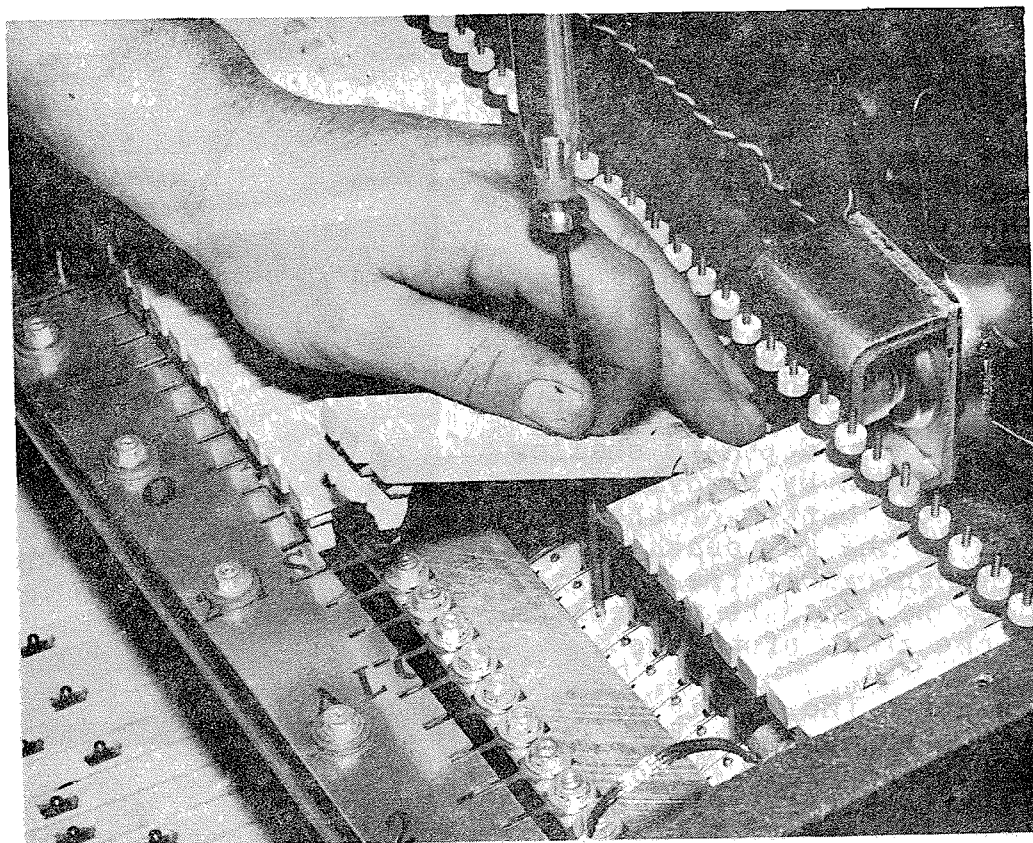

VIEW SHOWING METHOD OF ADJUSTING REGULATING SCREW.

Fig. 8

## MODEL 112-A

### LEVEL KEYS

Key leveling the Model 112-A is essentially the same as the Model 112. The key height, however, is  $1 \frac{15}{32}$ " from the top of the key frame to the underneath side of the natural key lift. Note: (Refer to Page 11 in the Wurlitzer Electronic Piano Service Manual).

### CAPSTAN ADJUSTMENT

This is covered under the following section devoted to Touch.

### TOUCH

Determine if the key depth is satisfactory to the present setting of key height. These are: Natural,  $\frac{3}{8}$ " measured at face of key. Sharps,  $\frac{5}{16}$ " measured over pin.

If the key depth is shallow, it may be increased by removing material from the bottom of the front of the key. If the key depth is too deep, paper punchings of the required thickness may be glued to the bottom surface of the front of the key.

Trials should be taken at keys No. 1, 32 and 64. The capstan screw (Item 6, Diagram A) (also Page 9, Figure 7) and butt regulating screw (Item 35, Diagram A) should be adjusted so the hammer lets off  $\frac{1}{8}$ " away from the striking point with at least  $\frac{1}{32}$ " of after touch and a hammer blow distance of  $1 \frac{1}{8}$ ". The striking point would be  $4 \frac{15}{16}$ " above the keybed.

The butt spoon (Item 9, Diagram A) has been factory-set and should not require adjustment. The spoon is bent out just far enough so the capstan screw (Item 6, Diagram A) will escape to the fly leather (Item 7, Diagram A).

THE PROPER SETTING OF THE BUTT SPOON (Item 9, Diagram A) is when the spoon clears the fly stop cloth (Item 8, Diagram A) by  $\frac{1}{32}$ " after the key is fully depressed and let-off has been obtained.

Improper setting of the butt spoon (Item 9, Diagram A) is when the spoon does not clear the fly stop cloth (Item 8, Diagram A) after the key is fully depressed. Full let-off will not result.

### DAMPER ADJUSTMENT

Adjust the damper lever lift dowel (Item 25, Diagram A) so that when the hammer (Item 13, Diagram A) has travelled one third the distance to the reed (No. 14) the damper (No. 20) will just start to lift. The bass note dampers will have to start quicker and have more lift to keep from dampening the reed.

1. Front Rail Pin
2. Key
3. Music Desk Assembly
4. Balance Rail Pin
5. Key Cloth
6. Capstan Screw
7. Fly Leather
8. Fly Stop Cloth
9. Butt Spoon
10. Butt
11. Pick-Up Insulator
12. Reed Bar
13. Hammer
14. Reed
15. Shield
16. Pick-Up Washer
17. Pick-Up Screw
18. Pick-Up Bushing
19. Pick-Up
20. Damper
21. Reed Screw
22. Reed Washer
23. Damper Lever
24. Damper Lever
25. Damper Lever
26. Damper Lever
27. Damper Rod
28. Damper Rod
29. Damper Rod
30. Damper Lever Flange Spring
31. Action Rail
32. Butt Screws
33. Butt Flange
34. Fly Regulating Leather
35. Butt Regulating Screw
36. Fly
37. Amplifier
38. Speaker
39. Threaded Damper Rod

NOMENCLATURE

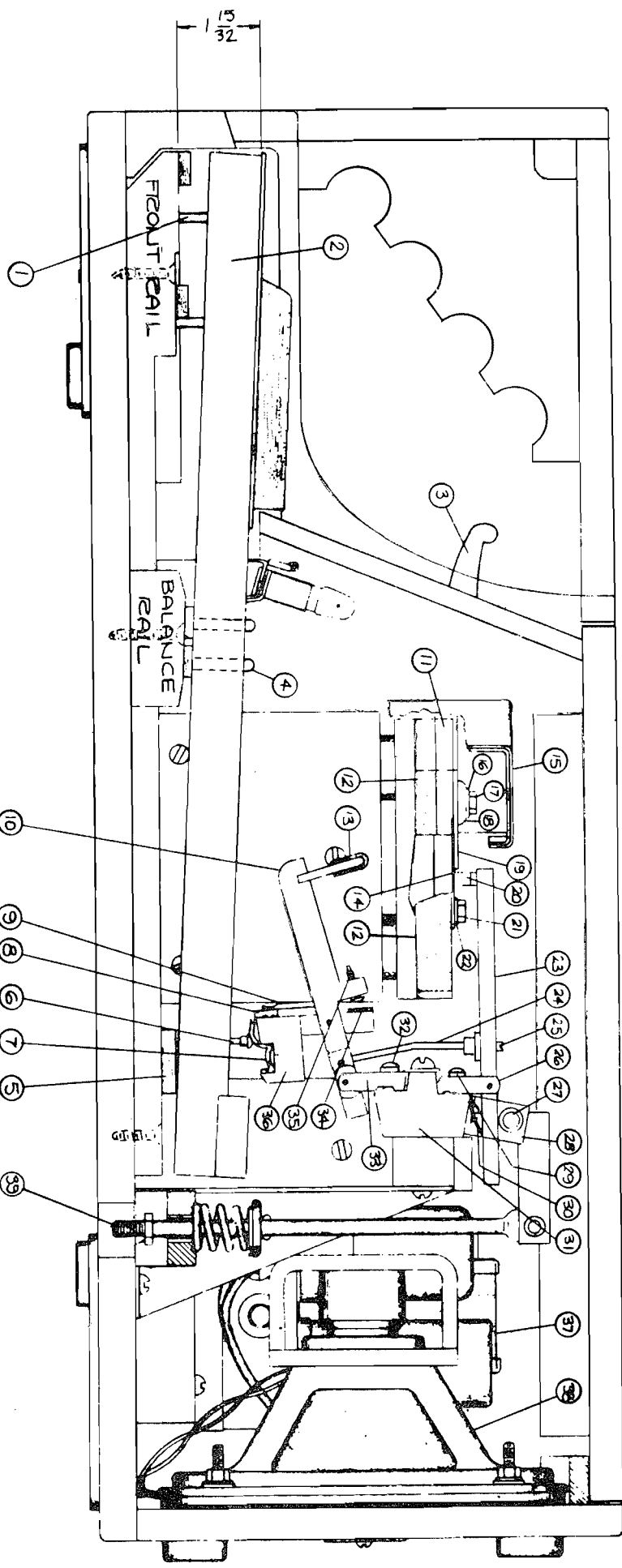

WURLITZER ELECTRONIC PIANO MODEL 112a  
(U.S. AND FOREIGN PATENTS PENDING)

Diagram A

### LEVEL KEYS

If key leveling is necessary, it can be done by removing or adding paper punchings under the felt washers on the balance rail. Set keys, #1, #32 and #64, 1-13/32" from the top of the keyframe to the underneath side of natural key lip (refer to Fig. 6). By using three check points, key leveling is simplified.

Level sharps so that the top surface of the wood key body, directly behind the plastic cap, is slightly below the plastic top of the natural key. Using sharps #2, #31, and #62 as trials, level the sharps between these trials by using a straight edge across the top surface of the sharps. (For further instructions, please refer to the Wurlitzer Piano Service Manual).

### SPACE KEYS

Please refer to page 7 of Wurlitzer Piano Service Manual.

### DAMAGED KEYS

Please refer to page 7 of Wurlitzer Piano Service Manual.

### DAMPER ADJUSTMENT

Adjust the damper button (No. 32, Fig. 6) so that when the hammer (No. 16, Fig. 6) has traveled half the distance to the reed (No. 17, Fig. 6) the damper (No. 26, Fig. 6) will start to lift off the reed.

Adjustment is made by turning the damper button down to lift off fast and up to lift off slower. Be sure the damper lifts high enough on the bass section to clear the reed while it is in full swing. Also be sure that enough lost motion is left in the adjustment of the damper button to insure damping of the reed.

### SPRING ADJUSTMENT

The damper is returned by a spring (No. 30, Fig. 6) and if the damping is too fast or slow it can be regulated by adjusting the springs.

### BLOCKING HAMMERS

Blocking hammers are caused by improper capstan screw (No. 6, Fig. 6) adjustment, improper regulating screw adjustment (No. 12, Fig. 6) or excessive key dip at point 1, Fig. 6; or it may be caused, of course, by a combination of two or three of the above. (Also see paragraph on "Touch" page 9).



### TONES NOT PRODUCED ON LIGHT BLOW

This condition is caused by hammers letting off too quickly, or too far away from the reed (see "Touch," page 9).

### SHRINKING ACTION

Please refer to page 12 of Wurlitzer Piano Service Manual. However, before shrinking action centers, turn the instrument on for several hours. The heat from the amplifier may dry out the action sufficiently to make shrinking unnecessary.

### CENTER PIN REPLACEMENT

Please refer to page 16 of Wurlitzer Piano Service Manual.

### ADJUSTING AND CHECKING REEDS

If a reed should need tuning at any time, it may be taken care of by a piano tuner. The only difference in tuning is that instead of pulling a string up to pitch, the tuner will be tuning a vibrating reed (see Fig. 5). If the reed is flat, the pitch may be raised by removing some of the lead at the end of the reed by scraping. If the reed is sharp, it may be tuned by adding lead to the end of the reed.

Adding weight to the end of the reed is the better method and should be used if possible. Filing, unless expertly done, can ruin the reed by weakening it and removing the protective coating which keeps it from rusting.

Should it be necessary to remove or repair a reed, first remove the shield (No. 24, Fig. 6) by removing two screws. The reed can then be taken out by removing reed screw (No. 27, Fig. 6). The reed can be replaced or a new one installed by carefully watching the spacing between the reed and the pickup (No. 25, Fig. 5&6) when tightening reed screw. See paragraph on Tone Producing Principle.

### CARING FOR THE FINISH

The Wurlitzer Electronic Piano Model 112 is finished in a durable, attractive pebble finish. This finish can easily be cleaned by merely wiping the case with a damp cloth, and then drying with a soft, dry cloth.

### CLEANING KEYS

Both natural and sharp keys may be cleaned by wiping them from back to front with a soft cloth moistened with warm water.

## AMPLIFIER

The amplifier is shown in Fig. 3 and on the schematic wiring diagram, Fig. 9. The Bill of Material, Fig. 9, shows the value of component parts. Voltages are measured on a Vacuum Tube Volt Meter (VTVM) and are indicated on the print. The piano volume control and line switch are one unit and its position is indicated in Fig. 4. NOTE: All tubes should be checked before working on the amplifier.

## EARPHONES

The "Phones" jack is clearly marked on the unit and is indicated in Fig. 4; the speaker is cut out when the earphones are plugged in. Any high or low impedance earphone will work satisfactorily. A second set of earphones may be plugged into the jack marked "speaker" if desired.

## EXTERNAL SPEAKER

Any external low impedance speaker (3 to 8 OHMS) may be plugged into the jack marked "speaker." Both the speaker in the unit and the external speaker will play when the external speaker is plugged into the "speaker" jack.

## EXTERNAL AMPLIFICATION

The amplifier in the Wurlitzer Electronic Piano may be used as a pre-amplifier to drive a higher powered amplifier by plugging into the jack marked "auxiliary output." This provides a high impedance output that can be fed into any standard mike, record, or musical instrument input.

## RECORD PLAYER JACK

Any high impedance phonograph pick-up (record player) may be fed into the record input jack of the Wurlitzer Electronic Piano. The volume is controlled by the record volume control knob indicated in Fig. 4.

The right balance between the phonograph and the Wurlitzer Electronic Piano may be obtained by individual adjustment of both the piano volume control and record volume control.

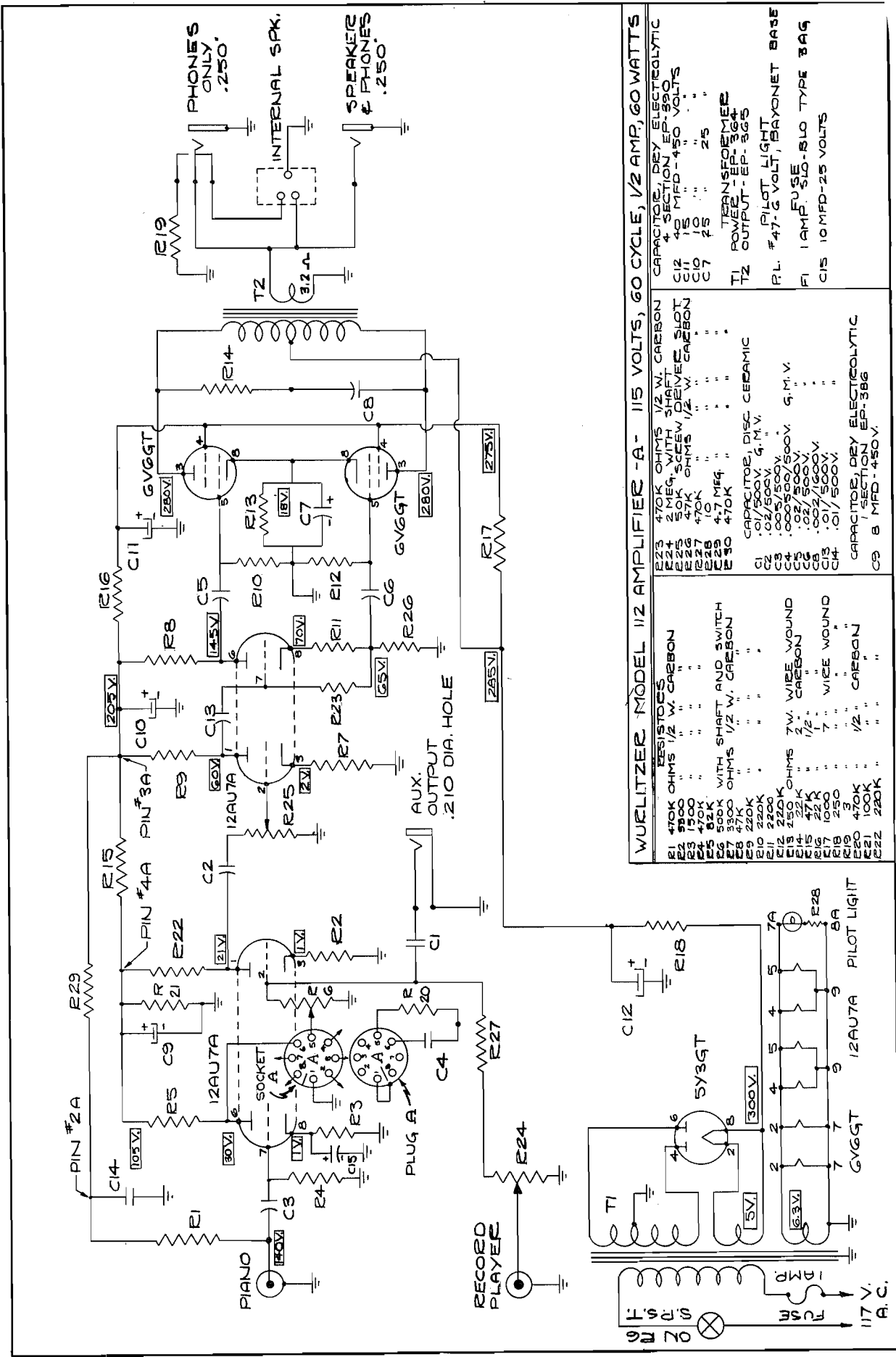

**WURLITZER MODEL 112 AMPLIFIER - A - 115 VOLTS, 60 CYCLE, 1/2 AMP, 60 WATTS**

RESISTORS		CAPACITORS, DRY ELECTROLYTIC	
R1	470K OHMS 1/2 W. CARBON	C12	4 SEC. SECTION EP-590
R2	500 "	C1	10 MFD-450 VOLTS
R3	1500 "	C7	" "
R4	470K "	C8	" "
R5	82K "	C9	" "
R6	3300 OHMS 1/2 W. CARBON	C10	" "
R7	47K "	C11	" "
R8	220K "	C12	" "
R9	220K "	C13	" "
R10	220K "	C14	" "
R11	220K "	C15	" "
R12	220K "	C16	" "
R13	220K "	C17	" "
R14	220K "	C18	" "
R15	220K "	C19	" "
R16	220K "	C20	" "
R17	275V "	C21	" "
R18	275V "	C22	" "
R19	275V "	C23	" "
R20	275V "	C24	" "
R21	275V "	C25	" "
R22	275V "	C26	" "
R23	275V "	C27	" "
R24	275V "	C28	" "
R25	275V "	C29	" "
R26	275V "	C30	" "
R27	275V "	C31	" "
R28	275V "	C32	" "
R29	275V "	C33	" "
R30	275V "	C34	" "
R31	275V "	C35	" "
R32	275V "	C36	" "
R33	275V "	C37	" "
R34	275V "	C38	" "
R35	275V "	C39	" "
R36	275V "	C40	" "
R37	275V "	C41	" "
R38	275V "	C42	" "
R39	275V "	C43	" "
R40	275V "	C44	" "
R41	275V "	C45	" "
R42	275V "	C46	" "
R43	275V "	C47	" "
R44	275V "	C48	" "
R45	275V "	C49	" "
R46	275V "	C50	" "
R47	275V "	C51	" "
R48	275V "	C52	" "
R49	275V "	C53	" "
R50	275V "	C54	" "
R51	275V "	C55	" "
R52	275V "	C56	" "
R53	275V "	C57	" "
R54	275V "	C58	" "
R55	275V "	C59	" "
R56	275V "	C60	" "
R57	275V "	C61	" "
R58	275V "	C62	" "
R59	275V "	C63	" "
R60	275V "	C64	" "
R61	275V "	C65	" "
R62	275V "	C66	" "
R63	275V "	C67	" "
R64	275V "	C68	" "
R65	275V "	C69	" "
R66	275V "	C70	" "
R67	275V "	C71	" "
R68	275V "	C72	" "
R69	275V "	C73	" "
R70	275V "	C74	" "
R71	275V "	C75	" "
R72	275V "	C76	" "
R73	275V "	C77	" "
R74	275V "	C78	" "
R75	275V "	C79	" "
R76	275V "	C80	" "
R77	275V "	C81	" "
R78	275V "	C82	" "
R79	275V "	C83	" "
R80	275V "	C84	" "
R81	275V "	C85	" "
R82	275V "	C86	" "
R83	275V "	C87	" "
R84	275V "	C88	" "
R85	275V "	C89	" "
R86	275V "	C90	" "
R87	275V "	C91	" "
R88	275V "	C92	" "
R89	275V "	C93	" "
R90	275V "	C94	" "
R91	275V "	C95	" "
R92	275V "	C96	" "
R93	275V "	C97	" "
R94	275V "	C98	" "
R95	275V "	C99	" "
R96	275V "	C100	" "

Fig. 9

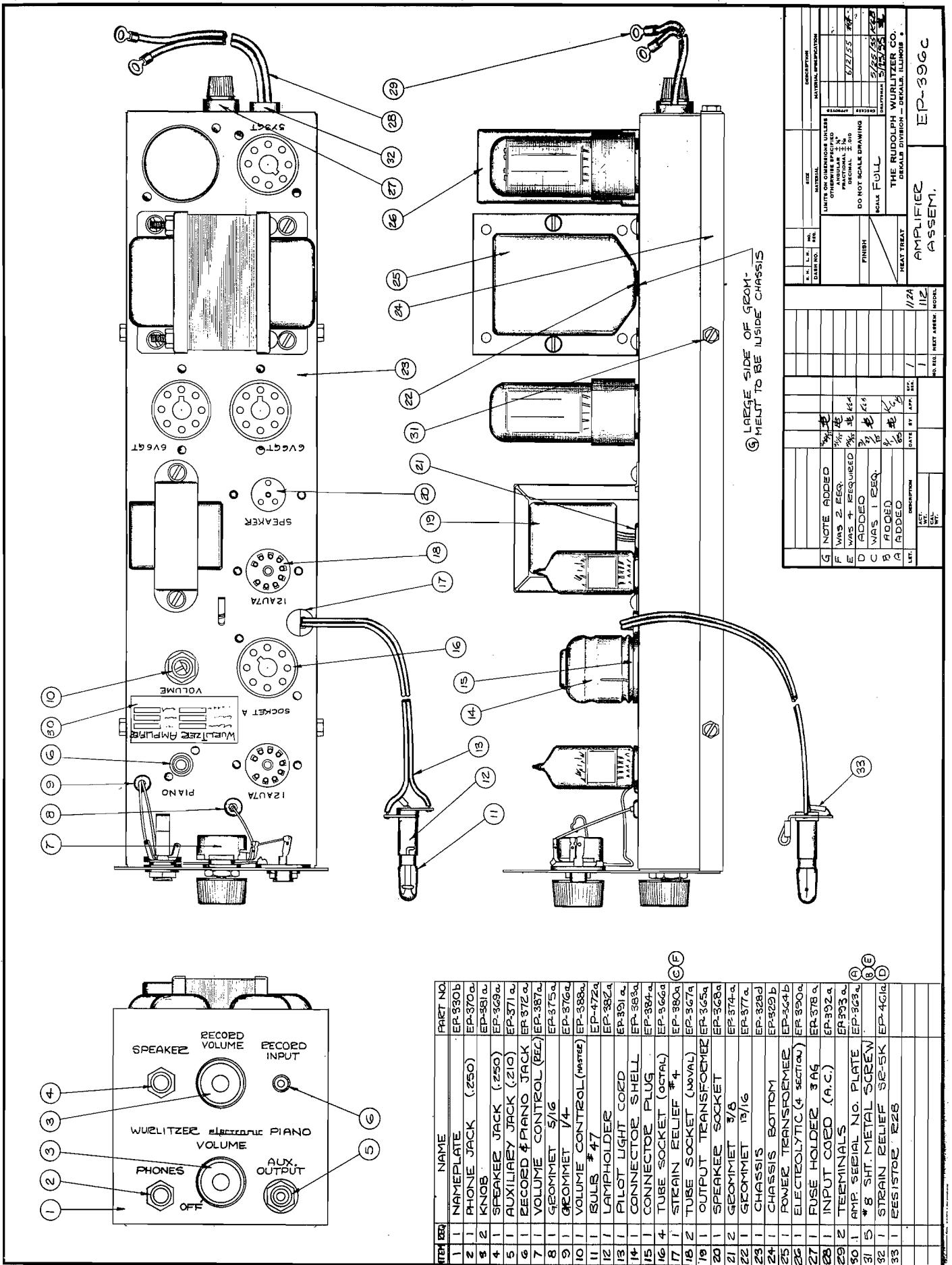

REV.	DATE	DESCRIPTION
1	6/27/55	INITIALS
2	5/15/56	REVISION
3	5/15/56	REVISION
4	5/15/56	REVISION
5	5/15/56	REVISION
6	5/15/56	REVISION
7	5/15/56	REVISION
8	5/15/56	REVISION
9	5/15/56	REVISION
10	5/15/56	REVISION
11	5/15/56	REVISION
12	5/15/56	REVISION
13	5/15/56	REVISION
14	5/15/56	REVISION
15	5/15/56	REVISION
16	5/15/56	REVISION
17	5/15/56	REVISION
18	5/15/56	REVISION
19	5/15/56	REVISION
20	5/15/56	REVISION
21	5/15/56	REVISION
22	5/15/56	REVISION
23	5/15/56	REVISION
24	5/15/56	REVISION
25	5/15/56	REVISION
26	5/15/56	REVISION
27	5/15/56	REVISION
28	5/15/56	REVISION
29	5/15/56	REVISION
30	5/15/56	REVISION
31	5/15/56	REVISION
32	5/15/56	REVISION
33	5/15/56	REVISION

ITEM	QTY	NAME	PART NO.
1	1	NAMEPLATE	EP-330b
2	1	PHONE JACK (.250)	EP-370a
3	1	KNOB	EP-381a
4	1	SPEAKER JACK (.250)	EP-369a
5	1	AUXILIARY JACK (.210)	EP-371a
6	1	RECORD & PIANO JACK	EP-372a
7	1	VOLUME CONTROL (REC.)	EP-387a
8	1	GEOMMET 5/16	EP-375a
9	1	GEOMMET 1/4	EP-376a
10	1	VOLUME CONTROL (PIANO)	EP-388a
11	1	BULBS # 47	EP-472a
12	1	LAMPHOLDER	EP-382a
13	1	PILOT LIGHT COED	EP-391a
14	1	CONNECTOR SHELL	EP-383a
15	1	CONNECTOR PLUG	EP-384a
16	4	TUBE SOCKET (OCTAL)	EP-366a
17	1	STRAIN RELIEF # 4	EP-380a
18	2	TUBE SOCKET (NOVAL)	EP-367a
19	1	OUTPUT TRANSFORMER	EP-365a
20	1	SPEAKER SOCKET	EP-368a
21	2	GEOMMET 3/8	EP-374a
22	1	GEOMMET 19/16	EP-377a
23	1	CHASSIS	EP-328d
24	1	CHASSIS BOTTOM	EP-329b
25	1	POWER TRANSFORMER	EP-364b
26	1	ELECTROLYTIC (4 SECTION)	EP-390a
27	1	FUSE HOLDER 3 AG	EP-378a
28	1	INPUT COED (A.C.)	EP-392a
29	2	TERMINALS	EP-393a
30	1	AMP SERIAL NO. PLATE	EP-363a
31	5	# 8 SMT. METAL SCREW	EP-363a
32	1	STRAIN RELIEF SE-5K	EP-461a
33	1	RESISTOR E2B	

Fig. 10

## SERVICE DEPARTMENT

Please refer to the Wurlitzer Piano Service Manual for complete instructions regarding the handling of service for the Wurlitzer Electronic Piano. All Wurlitzer Electronic Piano service inquiries should be directed to the SERVICE DEPARTMENT, THE RUDOLPH WURLITZER COMPANY, CORINTH, MISSISSIPPI.

## FILING CLAIMS WITH CARRIERS

Please refer to Page 26 of the Wurlitzer Piano Service Manual.

### IMPORTANT !!

Written authorization must be obtained from the Service Department, The Rudolph Wurlitzer Company, Corinth, Mississippi, before returning any Electronic Piano for repair. No claim for damage that has occurred can be considered by the carrier or by the Wurlitzer Service Department unless a full and complete explanation has been noted on the shipping papers.

\* \* \* \*

## CONCLUSION

The story of the development of the Wurlitzer Electronic Piano is a fascinating one. We urge you to read it in the Wurlitzer Electronic Piano Merchandising Program.

The Wurlitzer Electronic Piano and the comprehensive merchandising and promotion programs presented with it are available to authorized Wurlitzer Piano dealers only. And, in a like manner, the opportunity which this piano and this program present is available only to Wurlitzer dealers.

Once again, we encourage you to direct your comments and suggestions to our Service Department. They are anxious to be of service to you. And we cordially invite interested piano men wherever they may be to visit our piano factories at DeKalb, Illinois, and the Wurlitzer Electronic Piano plant at Corinth, Mississippi.

INDEX

<u>A</u>	<u>Page No.</u>
AC Cord.....	6
Action, Regulation of.....	9
Action, Shrinking.....	12
Amplification System.....	5
Amplifier.....	13,14,15
Amplifier, External.....	13
<u>B</u>	
Bar.....	7
Bench, Dimensions.....	3
<u>C</u>	
Cables.....	6
Capstan Adjustment.....	9
Center Pin, Replacement....	12
Claims, Filing of.....	16
Conclusion.....	16
Cross Section of Wurlitzer Electronic Piano.....	8
<u>D</u>	
Damper Adjustment.....	11
Diagram of Wurlitzer Electronic Piano.....	8
Dimensions.....	3
<u>E</u>	
Earphones.....	13
External Speaker.....	13
<u>F</u>	
Finish, Care of.....	12
Fuse.....	6
<u>H</u>	
Hammer, Let-Off (See Touch).	9
Hammers, Blocking.....	11
<u>I</u>	
Index.....	17
Introduction.....	1

<u>J</u>	<u>Page No.</u>
Jacks.....	13
<u>K</u>	
Keys, Cleaning.....	12
Keys, Damaged.....	11
Keys, Easing.....	9
Keys, Leveling.....	11
Keys, Spacing.....	11
<u>N</u>	
Notes.....	18
<u>P</u>	
Preparation of the Wurlitzer Electronic Piano For Sale.....	2
Pick-Up.....	7
Pilot Light.....	4
<u>R</u>	
Range.....	7
Record Player.....	13
Reeds.....	12
<u>S</u>	
Schematic Diagram of Amplifier.....	14
Service Department.....	16
Shield, Reed. Removal of..	12
Specifications.....	3
Spring Adjustment.....	11
Switch.....	6
<u>T</u>	
Tone Principle.....	7
Touch.....	9
Tubes.....	5,14,15
<u>V</u>	
Voltages.....	3,14
Volume Control.....	6



NOTES