



**VINTAGE VIBE
ELECTRIC PIANO CO.**

FENDER RHODES &
VV STEREO CONSOLE
SPEAKER WIRING DIAGRAM

TABLE OF CONTENTS

PETERSON SUITCASE (32 OHM SPEAKERS).....	PAGE 2
PETERSON SUITCASE (8 OHM SPEAKERS).....	PAGE 3
JANUS SUITCASE (8 OHM SPEAKERS).....	PAGE 4
VV STEREO CONSOLE (32 OHM SPEAKERS).....	PAGE 5

PETERSON SUITCASE (32 OHM SPEAKERS - STOCK)

Parallel Wiring

REAR BAFFLE

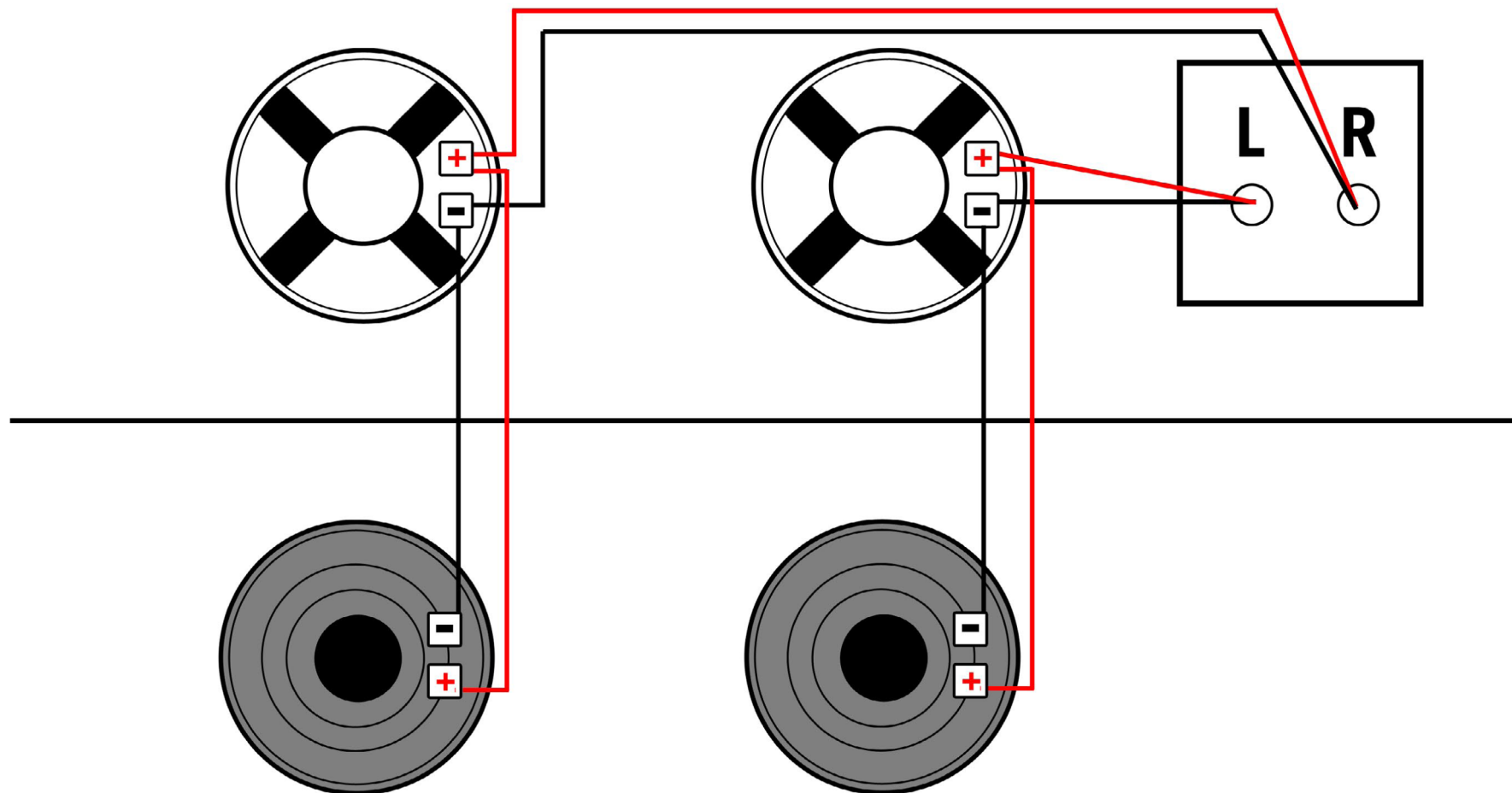

FRONT BAFFLE

PETERSON SUITCASE (8 OHM SPEAKERS)

Series Wiring

REAR BAFFLE

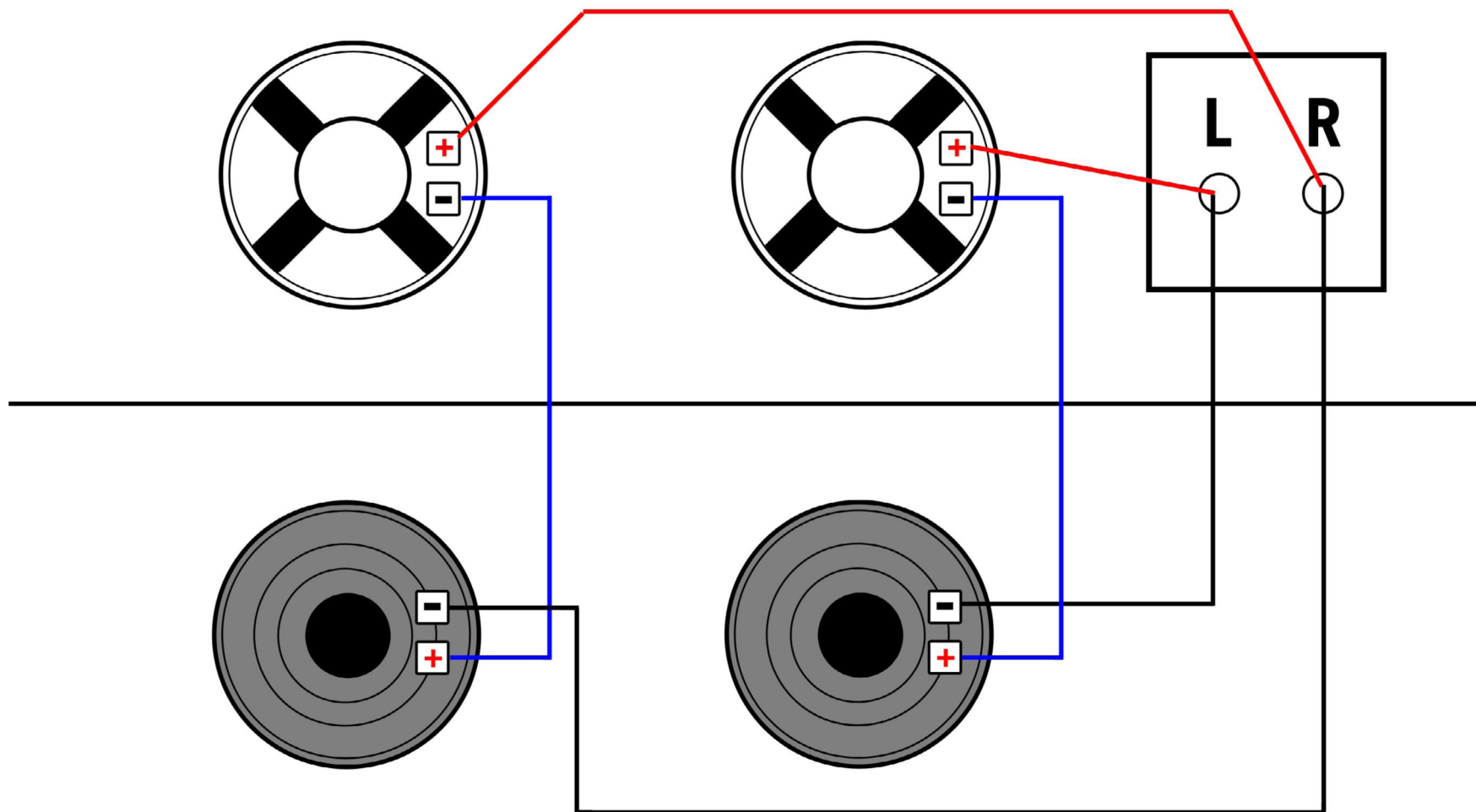

FRONT BAFFLE

JANUS SPEAKERS (8 OHM SPEAKERS)

Parallel Wiring

REAR BAFFLE

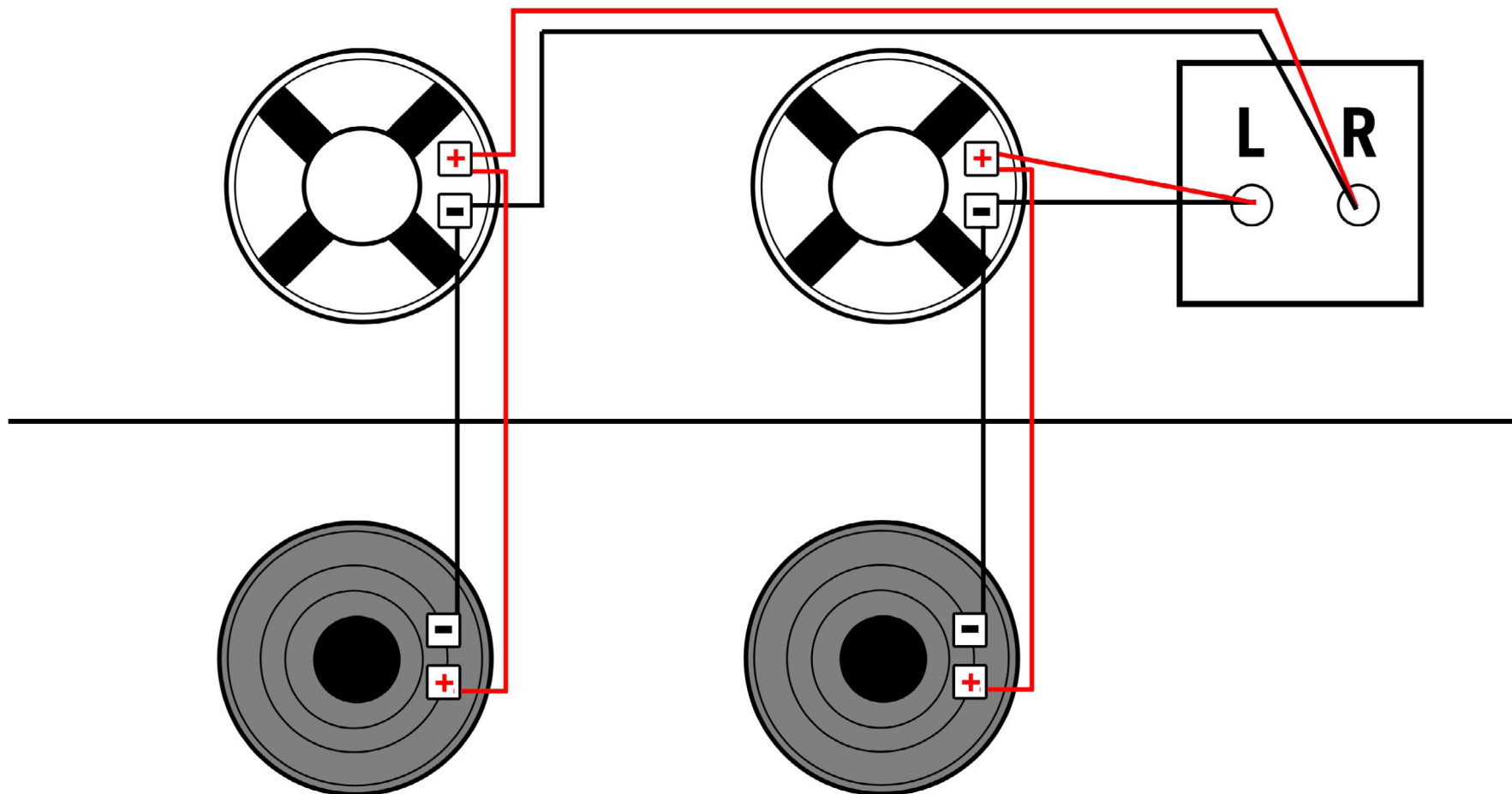

FRONT BAFFLE

VV STEREO CONSOLE (8 OHM SPEAKERS)

REAR BAFFLE (10")

Series Wiring
10" out of phase

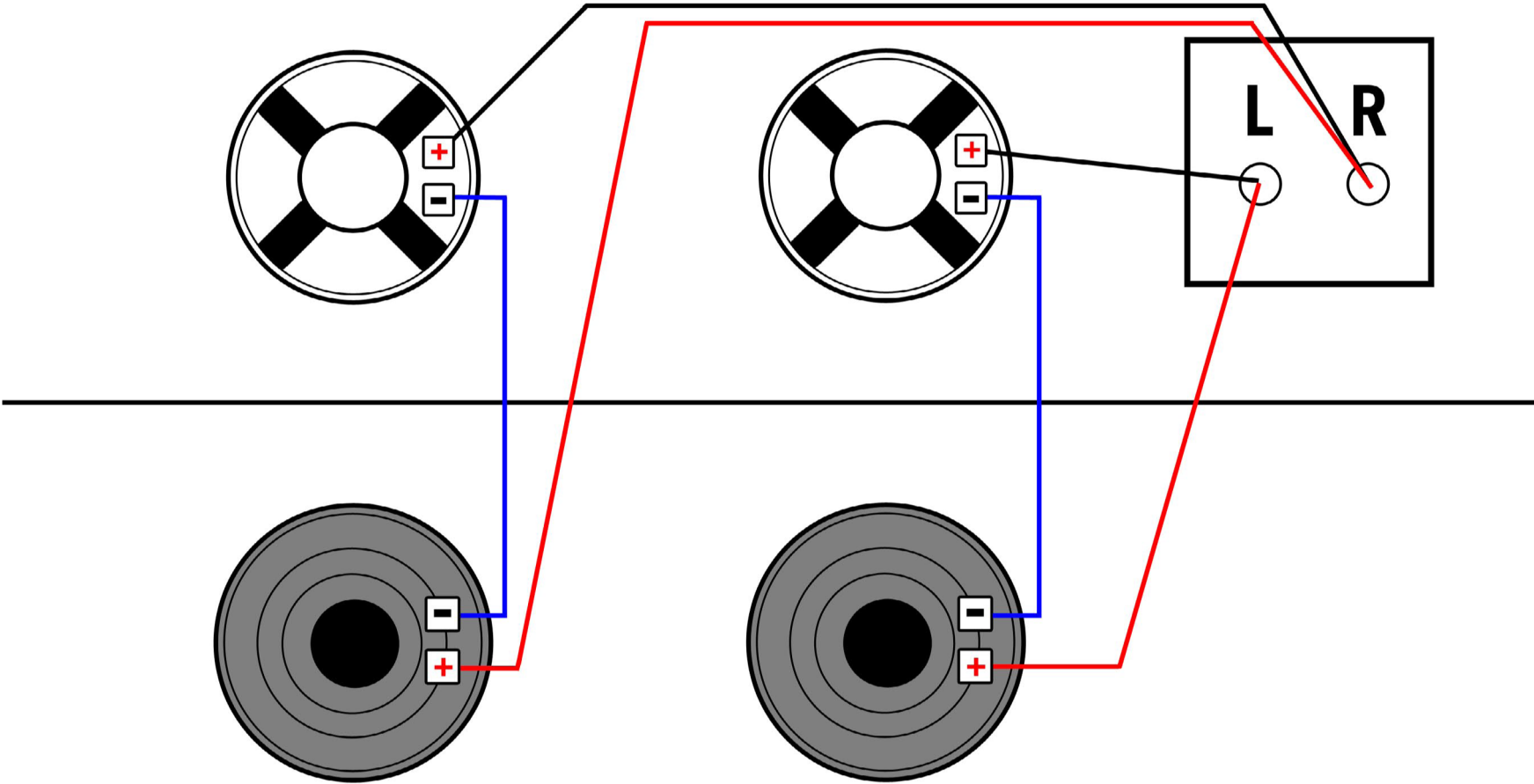

FRONT BAFFLE (12")