

SELECT
STONE

A REALLY EASY GUIDE TO YOUR NEW PAVING



Easy clean



UV resistant



Long lasting



Hard wearing



Low maintenance



R11 minimum slip rating

Contents

INTRODUCTION..... 3

BEFORE YOU GET STARTED

1. Shopping list	7	3. Planning	10
2. Storage and handling	8	3.1 Measuring and ordering.....	10
2.1 Storage.....	8	3.2 Planning your pattern.....	11
2.2 Handling.....	9		

LAYING YOUR PAVING

4. Laying your paving	19
4.1 Preparing the ground	19
4.2 Preparing the mortar mix	23
4.3 Laying the first slab.....	25
4.4 Laying subsequent slabs.....	15
4.5 Leave to set.....	35
4.4 Applying grout.....	36

CARE AND SUPPORT

5. Maintenance	38
-----------------------------	-----------

Introduction

Congratulations on taking the first step towards your brand new outdoor paving.

We love our porcelain paving slabs because they're the most low-maintenance outdoor slabs available.

Thanks to their dense composition, porcelain slabs are significantly less porous than most natural paving options. This makes porcelain paving more resistant to damp and stains.

It also makes it much harder for mould and fungus to grow. Making it much easier for you to clean and maintain your lovely new patio or path.

WHAT IS PORCELAIN PAVING?

Porcelain paving is made from very fine sand and feldspar, which are added to refined clay in a kiln. The slabs are baked at very high temperatures and under extreme pressure to eliminate cavities and voids. The result is a material that's hard-wearing and scratch-resistant.



**UV
RESISTANT**



**HARD
WEARING**



**LONG
LASTING**



**EASY
INSTALL, LOW
MAINTENANCE**



**EASY
TO CLEAN**



**R11 MINIMUM
SLIP RATING**

OUR PORCELAIN PAVING RANGES

Mizo

600mm x 600mm

Available in:

- Beige
- Light grey
- Dark grey

Smooth in texture, with an elegant swirl that resembles Venetian plaster.

Aravalli

600mm x 900mm

Available in:

- Beige
- Light grey
- Dark grey

A stony stone with a strong natural vein.

Zaskar

600mm x 900mm

Available in:

- Beige
- Light grey
- Dark grey

A quartz effect with natural variations in granulation and colour.

Kandla

600mm x 600mm

600mm x 900mm

Also available in project packs (600mm x 900mm, 600mm x 60mm, 600mm x 296mm, 296mm x 296mm)

Available in:

- Kandla grey

The famous sandstone effect in porcelain.

OUR ITALIAN PORCELAIN PAVING RANGES

Solaro

600mm x 900mm

Available in:

- Beige
- Light grey
- Taupe

Soft stone look with subtle detailed veining and tonal variations.

Cristallo

500 mm x 1000mm

Available in:

- White
- Beige
- Light grey

Dramatic stone look, with realistic veining and strong slate effects.

Paradiso

610mm x 1220mm

Available in:

- Beige
- Light grey
- Dark grey

Large format slab with realistic veining and a R12 slip rating to ensure safety.

**BEFORE YOU GET
STARTED**

1. Shopping list

You may need some or all of the following tools and materials to complete your project. We recommend that you read through this guide before you start to determine what additional supplies you will need. All items can be found in your local builder's merchant.

- Spade
- Wheel barrow
- String line
- Spirit level
- Trowel
- Whacker plate
- 4 inch grinder
with porcelain blade
- Wet saw
with porcelain blade
- Cement mixer
- Soft brush
- Type 1
- Geotextile membrane
- Sharp sand
- Cement
- Grout
- Tile spacers
- Paving primer
- Rubber mallet
with white head

2. Storage and handling

2.1 Storage

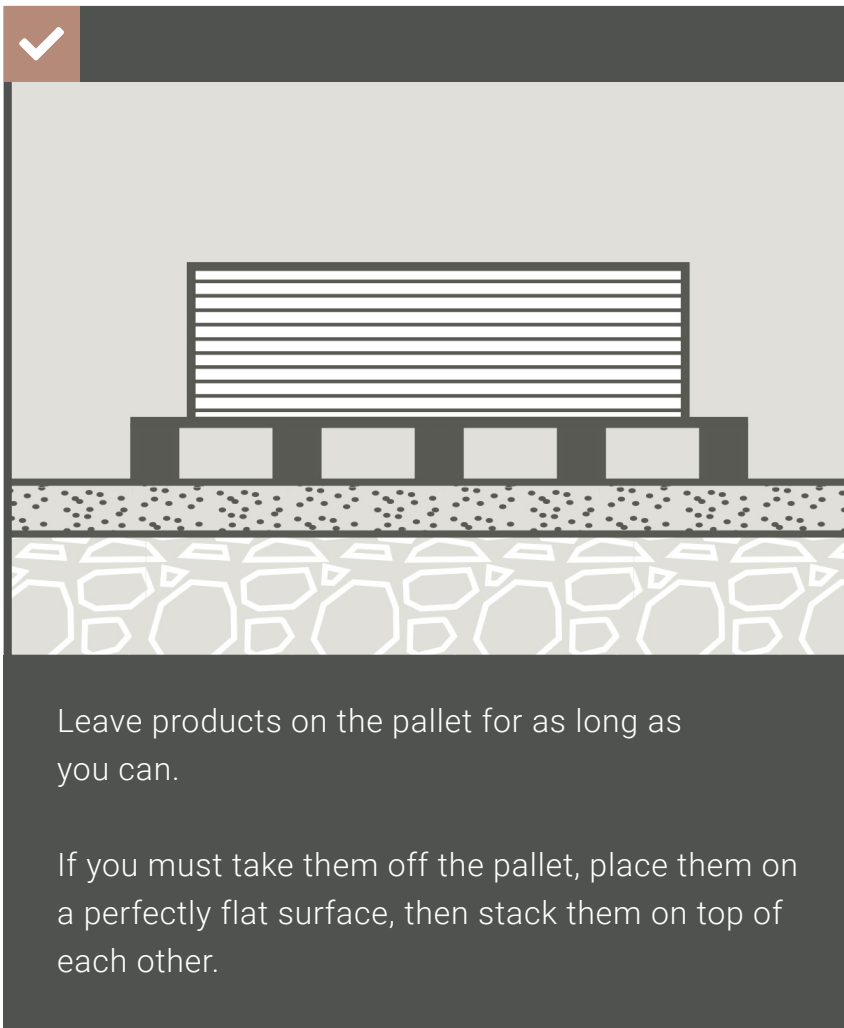

BE CAREFUL!

Once laid, porcelain paving is extremely durable, but until this point slabs are **VERY FRAGILE** and can easily chip if due care is not taken.

This is why we strongly advise leaving them on the pallet until you are ready to lay them.

2.2 Handling

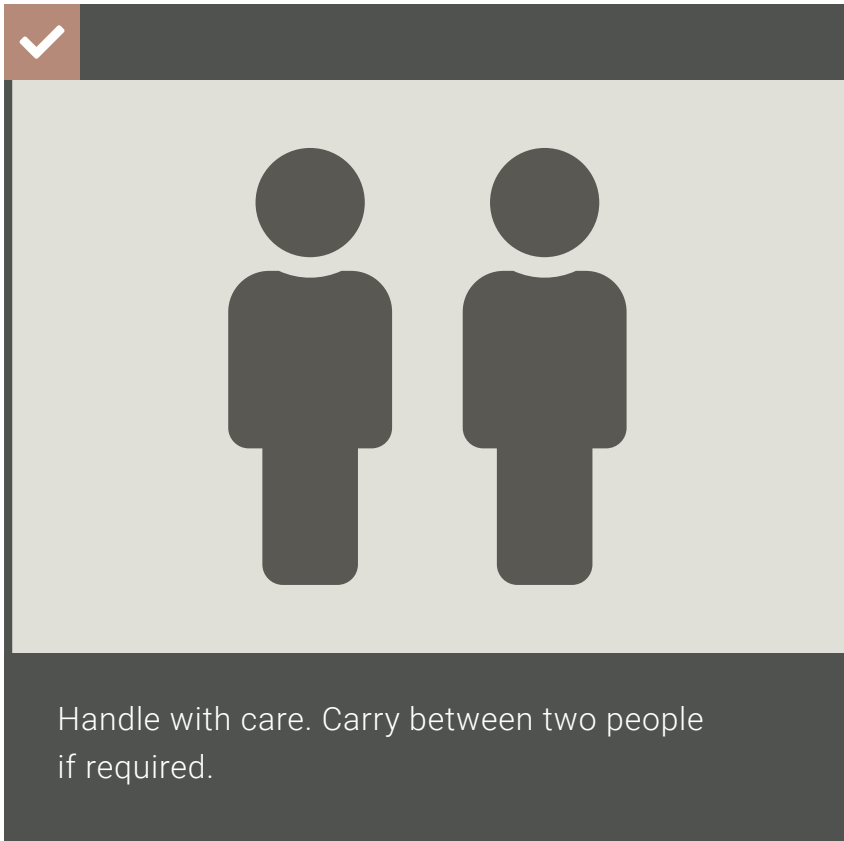

HEAVY ITEMS



Place slabs down carefully.
DO NOT dump.



DO NOT slide or drag equipment across slabs.



DO NOT slide slabs against each other when handling.

3. Planning

3.1 Measuring and ordering

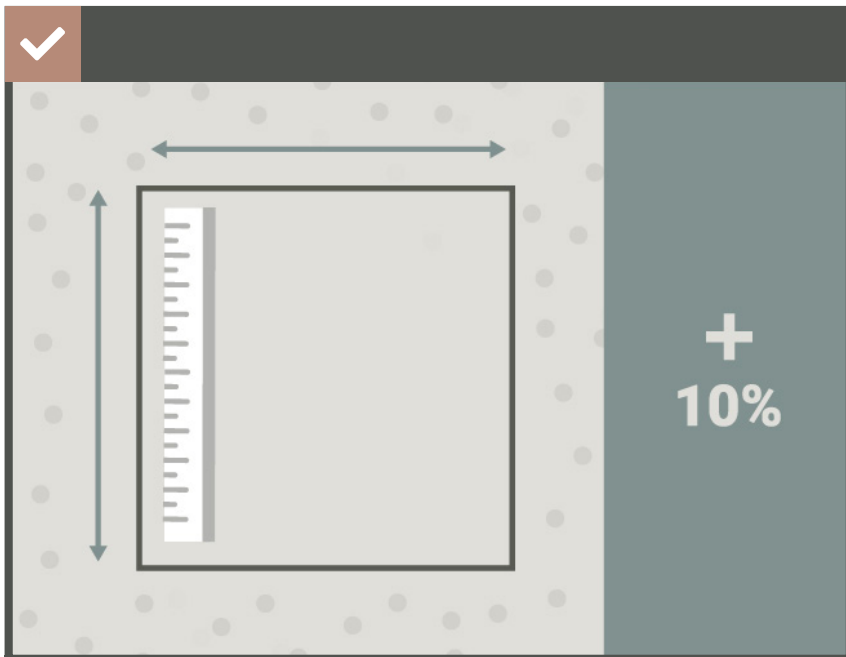

The diagram illustrates the process of measuring a rectangular area. A ruler is placed vertically on the left side of a rectangular area. A horizontal double-headed arrow above the rectangle indicates its width, and a vertical double-headed arrow to the left of the rectangle indicates its height. To the right of the rectangle, a dark grey box contains a white plus sign and the text "10%", indicating that 10% extra material should be ordered for cutting and wastage.

Measure the area you plan to pave. We recommend ordering 10% extra material for cutting and wastage.

3.2 Planning your pattern

Porcelain paving slabs can be laid in all sorts of patterns to achieve different effects.

We recommend planning your pattern out before you start to avoid mistakes.

NOTE: BOWS AND LIPS

Porcelain slabs over 750mm may have a slight bow to them. This is a natural result of the drying process. The bow can vary from none to a few mm.

If the slabs do have a slight bow, it means that when slabs are laid in a brick bond pattern (see pages 12 and 13), you might notice a slight lip where the middle of one tile sits alongside the edge of another.

Note that lips in your paving can interfere with water run-off, which is important to consider when planning your paving.

Use a spirit level to check the bow of your slabs. If they do have a slight bow, you may want to consider a pattern than doesn't use the brick bond method.



Laying porcelain paving requires accuracy. Any errors in spacing and alignment will show up, so plan your pattern carefully before beginning.

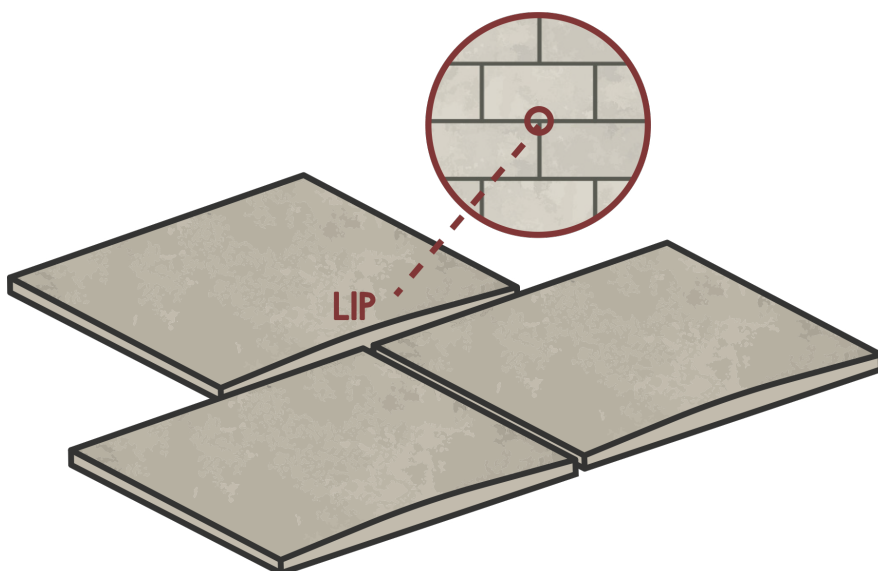

Lip exaggerated in diagram for illustrative purposes.

Check out the diagrams for some examples of the best way to lay our porcelain paving slabs.

FOR RECTANGULAR SLABS (E.G. ARAVALLI)

✓

1/2

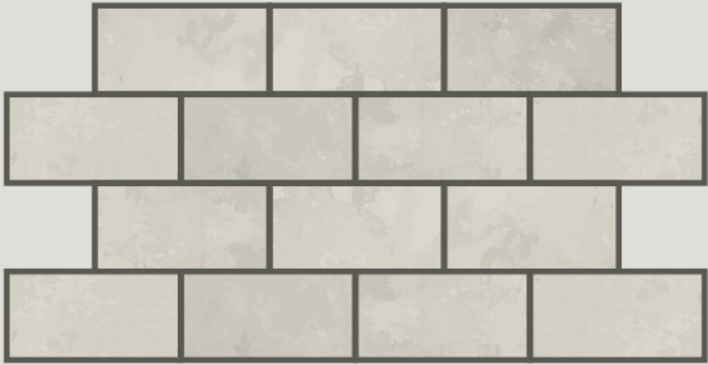

Brick bond (also known as a staggered joint) - 1/2.
For a 1/2 pattern, lay adjacent rows 50% across the previous row.



1/3

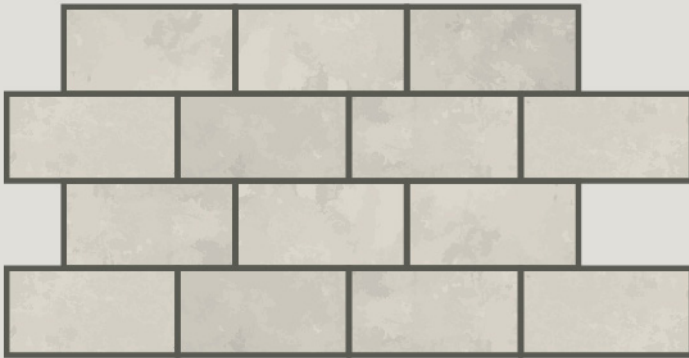

1/4



Brick bond - 1/3 & 1/4. Like the 1/2 brick bond, but with variations in the stagger.



LINEAR



Linear brick

FOR SQUARE SLABS (E.G. MIZO)

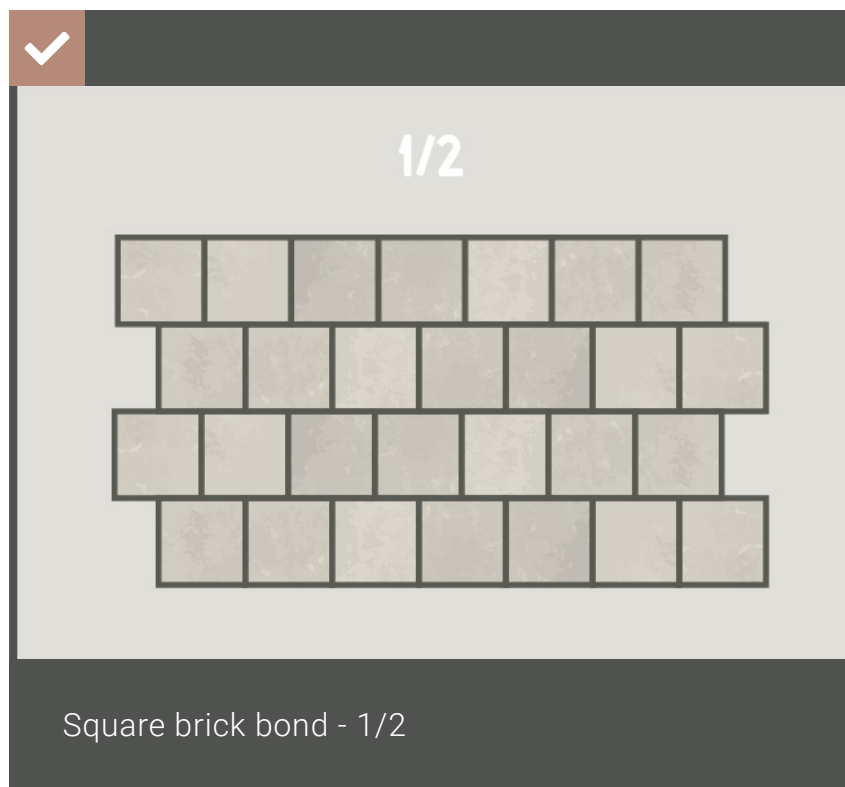
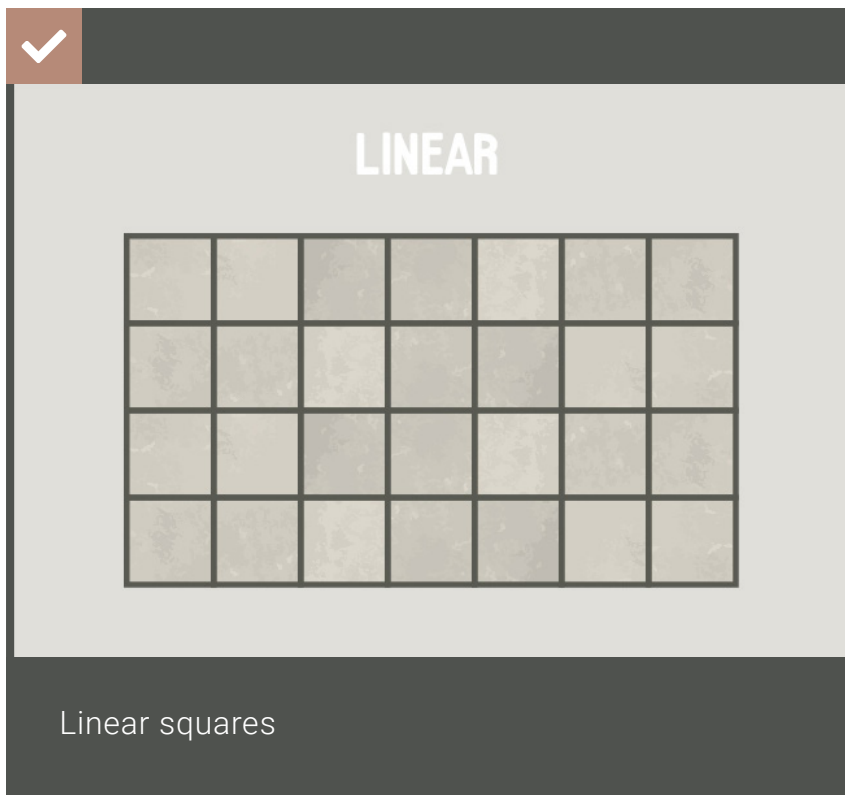



STAGGERED

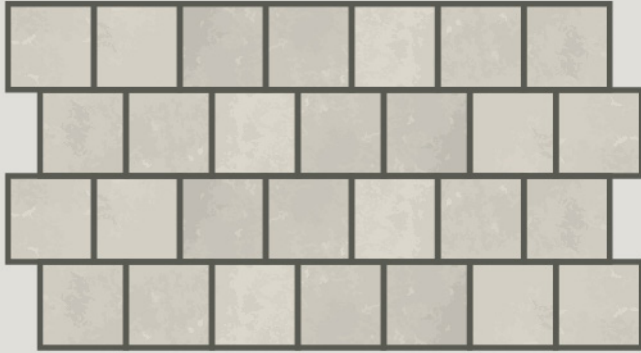

Staggered squares



As with the brick bond method, you can stagger square slabs any degree. The key is uniformity in the pattern.

FOR MIXED SLABS (E.G. THE KANDLA PROJECT PACK)

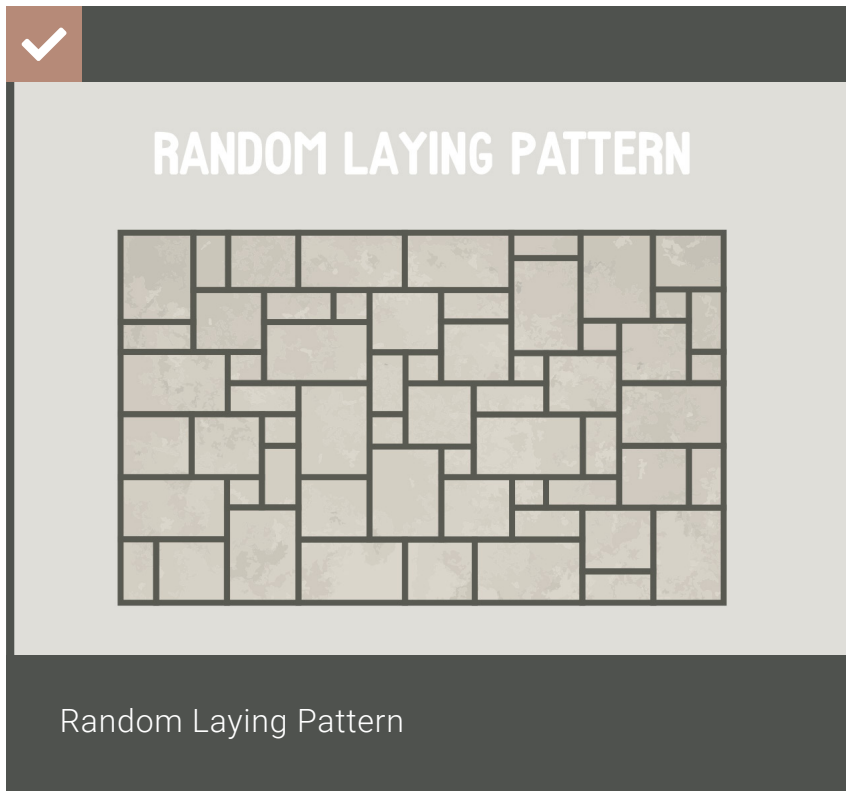

The combination of different slab sizes in our Kandla project pack allows you to replicate natural stone for a traditional appearance.



This kind of pattern requires more planning, so make sure you know where each slab is going before you start.

LAYING YOUR
PAVING

4. Laying your paving

4.1 Preparing the ground

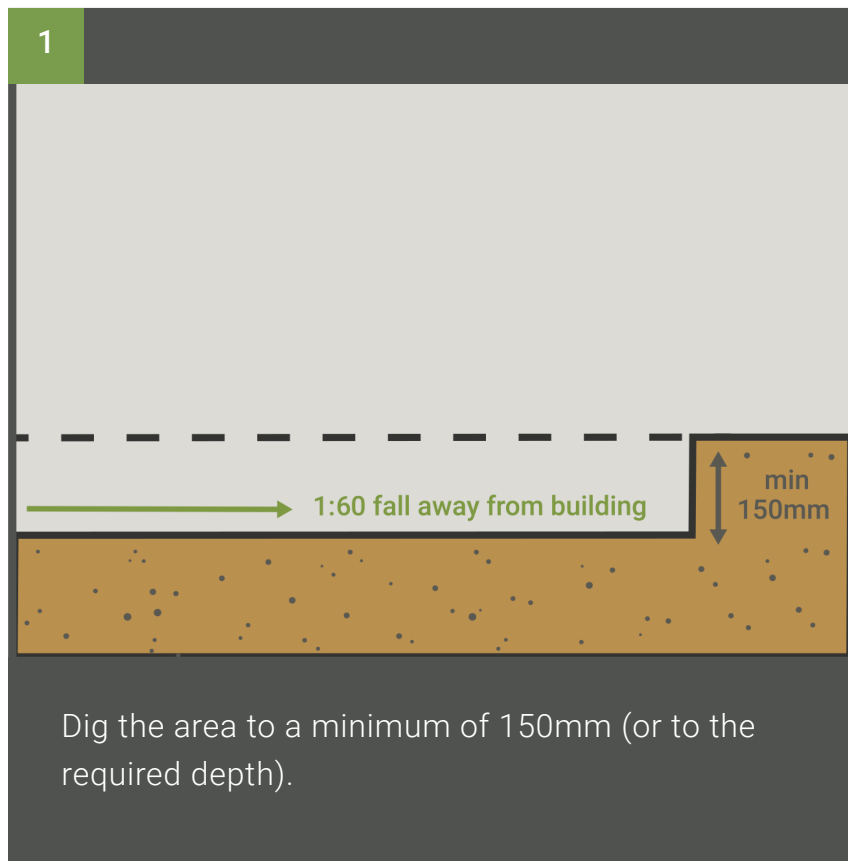

Ensure that you lay your patio on a 1:60 fall. This means for every 60 units of distance, the surface level should drop by 1 unit. This will ensure appropriate water run-off.



If you have to fall your patio towards the house, make sure the water runs off into the appropriate channel to be drained.



In some instances where the ground consists of clay soil, a dig out of 200mm or more may be required to find "good ground".

4.1 Preparing the ground (continued)

2



Lay a geotextile membrane. This will help stabilise the base by stopping particle migration of the type 1 into the ground below.

4.1 Preparing the ground (continued)

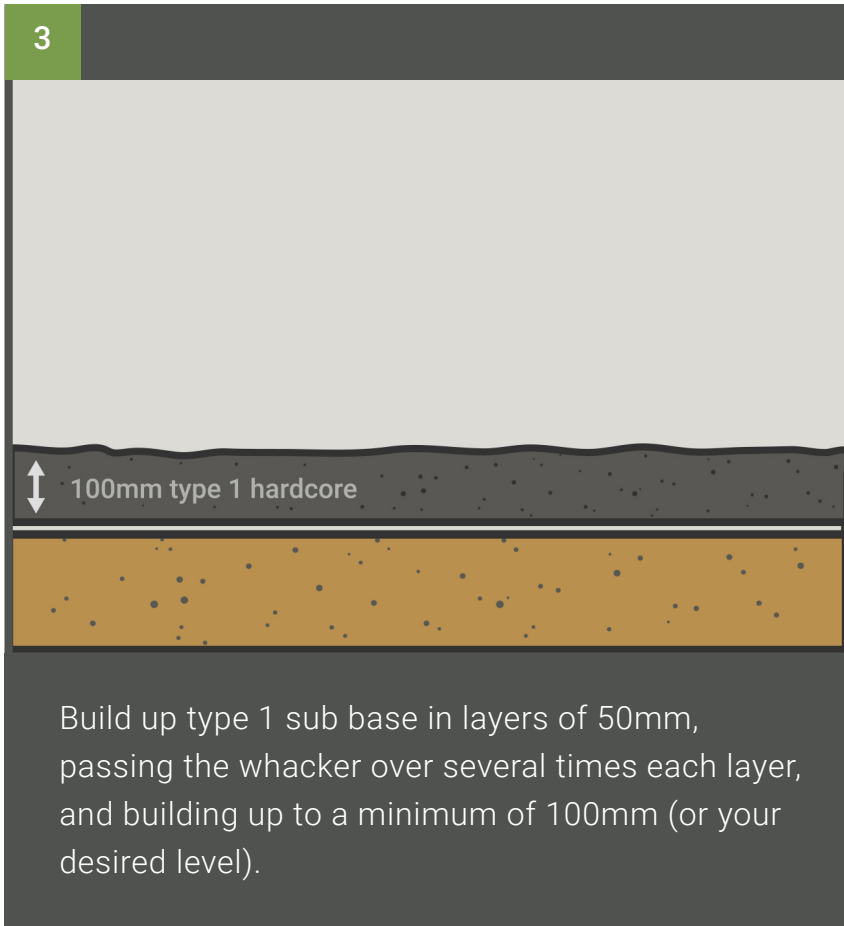

In some instances where the ground consists of clay soil, an infill of type 1 of over 200mm may be required.

4.1 Preparing the ground (continued)

4

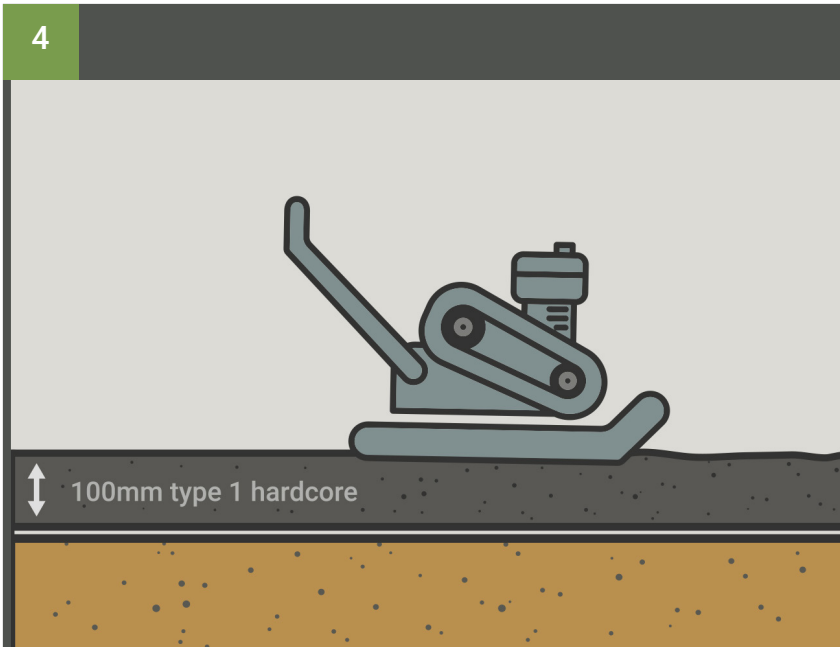

Compact the type 1 hardcore using a whacker plate / compactor plate. Give it several passes to ensure the aggregate is fully compacted.

4.2 Preparing the mortar mix

1

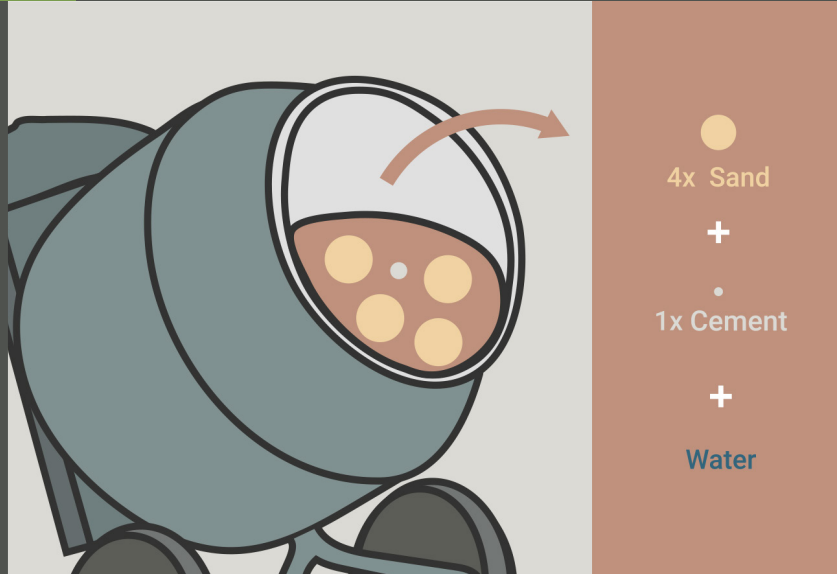

4x Sand
+
1x Cement
+
Water

Make a sharp sand and cement 4:1 mix. Try and keep it as consistent as possible. Add water to the mix. You want a consistency with which you can make a ball and it keeps its shape.



This step can only be done if the temperature is 3° and rising, otherwise you risk the paving failing in the future.



Instead of mixing the mortar, you can use our **Fuga Pave Part A**, a hybrid mortar designed to work with **Fuga Primer** for even greater cohesion between your bed and the paving.

Follow the manufacturer's instructions.



This method will create a non-permeable base, which is worth noting for when it comes to grouting your patio (pg 36).

4.2 Preparing the mortar mix (continued)

2

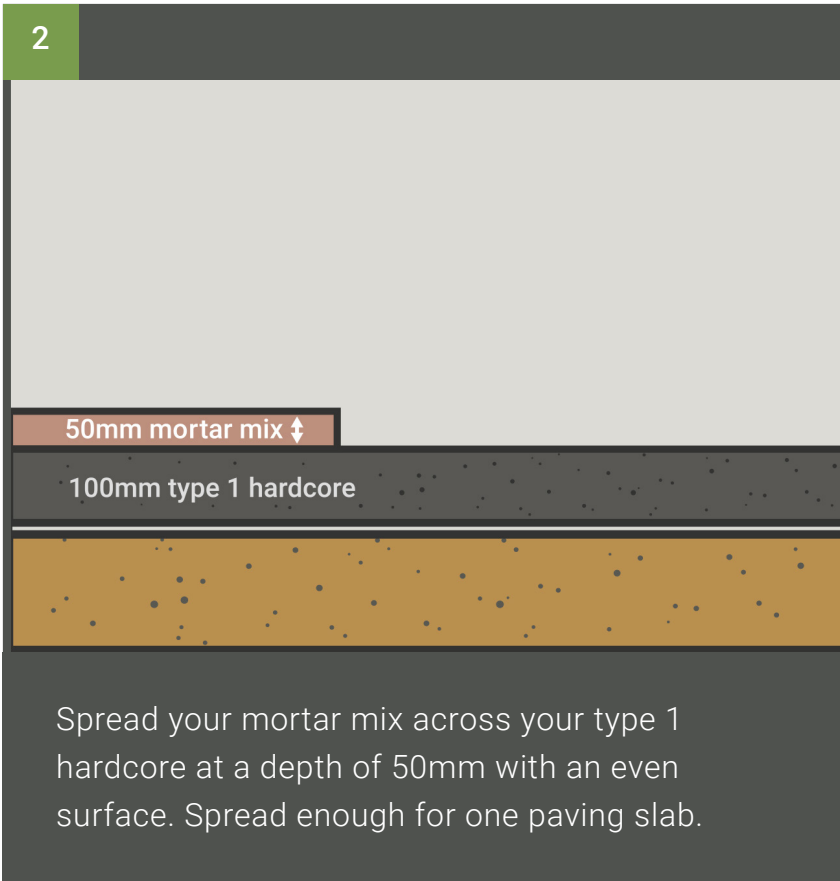

Do not "fluff" your mortar mix. This can create hollow voids which will result in less cohesion between mortar and slab.

4.3 Laying the first slab

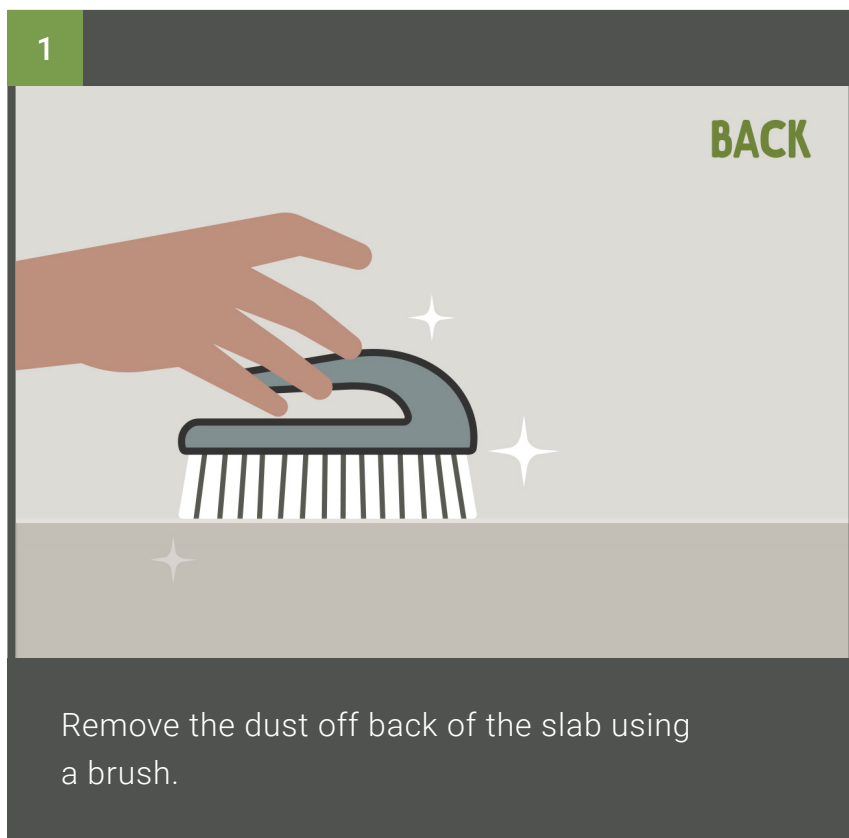

Failing to do this will mean that the primer may bond with the dust rather than the paving slab itself.

4.3 Laying the first slab (continued)

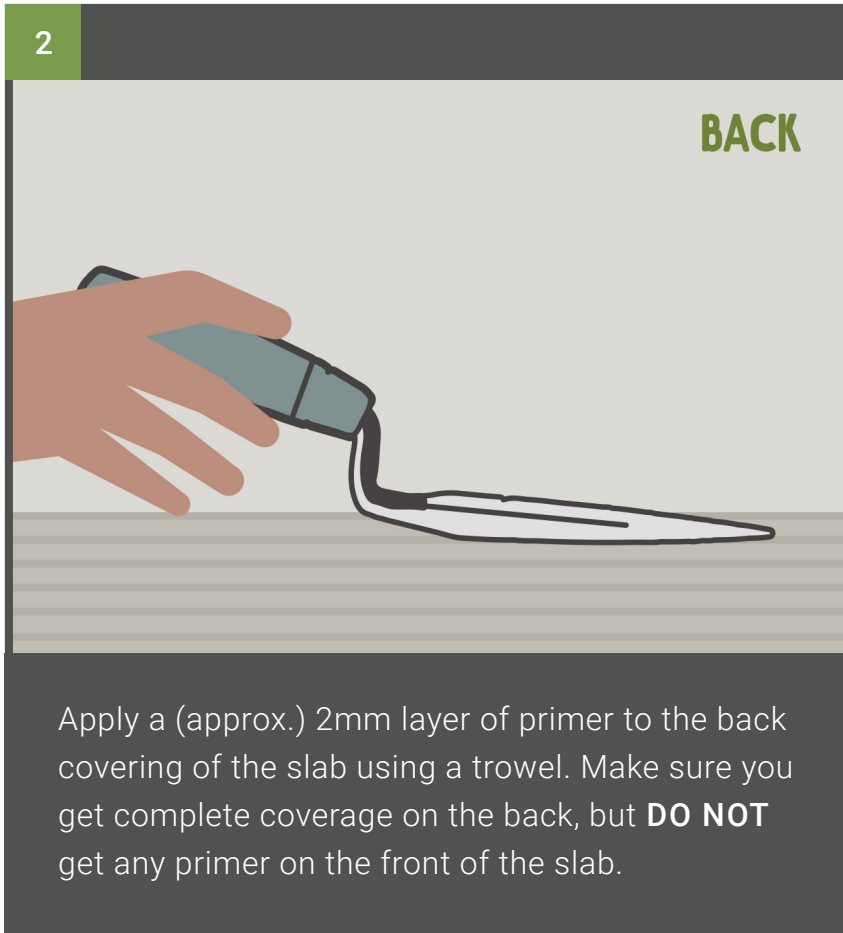

We recommend using **Fuga Pave Part B Slurry Primer**. Follow the manufacturer's instructions.

4.3 Laying the first slab (continued)

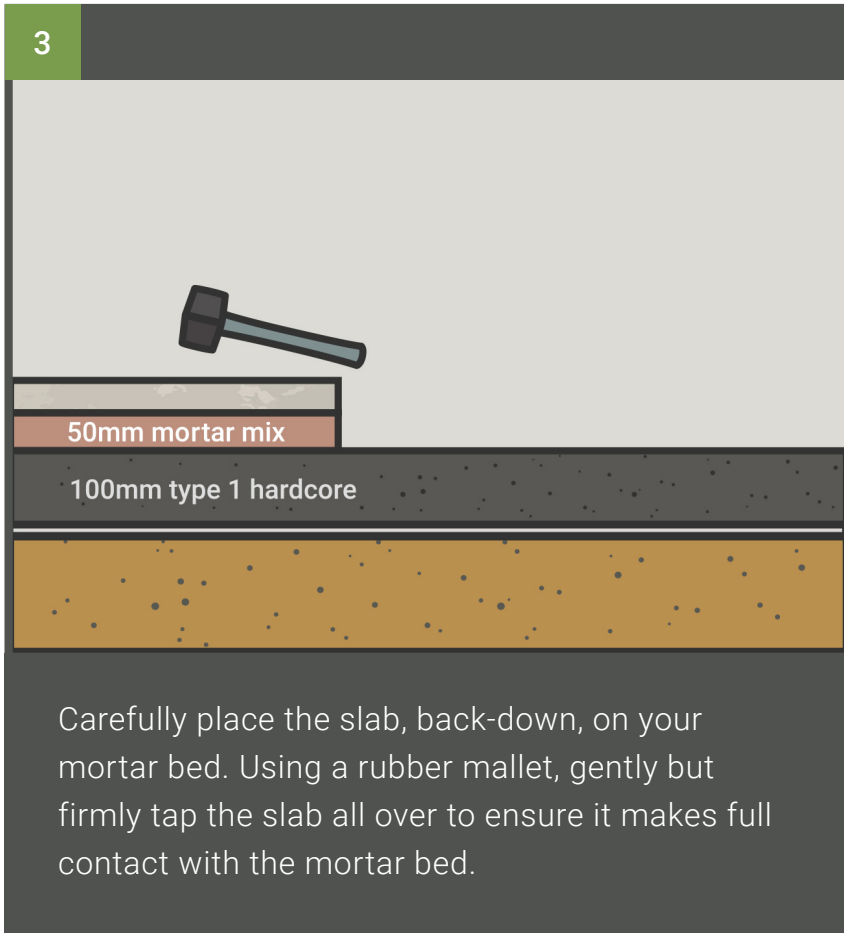

Any voids between the slab and mortar could result in a lack of cohesion later down the line.



Ensure the slab is laid on a 1:60 fall.

4.3 Laying the first slab (continued)

4

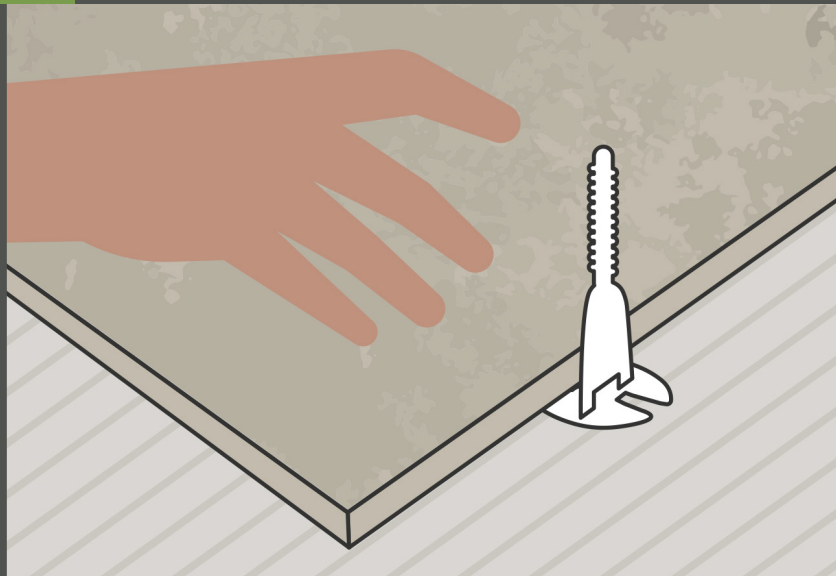

We recommend using a levelling kit to ensure your slabs are level.

Tuck 1mm threaded spacer clips along the edges of each slab. Do this along every edge that will be adjacent to another slab.



We recommend using a **Raimondi VITA Landscaper Levelling Kit**, available from our store.

4.3 Laying the first slab (continued)

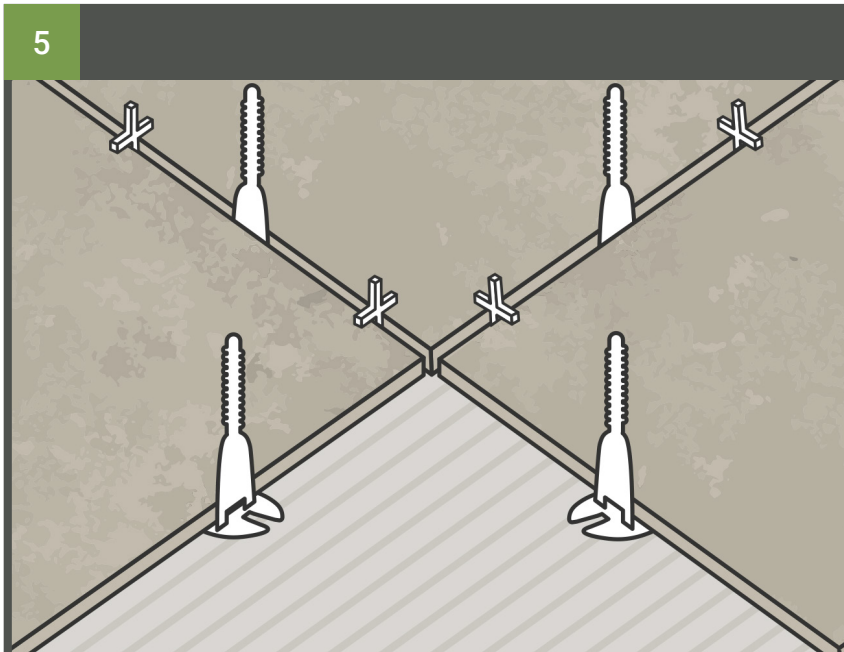

We recommend using spacers to ensure consistent spacing between slabs.

Tuck 5mm "+" or "T" spacers along the edges of the slab you just laid. Do this along every edge that will be adjacent to another slab. You may need two or three along each edge depending on the size of slab you're using.



We recommend using **Raimondi VITA 5m Spacers**, available from our store.

4.4 Laying subsequent slabs

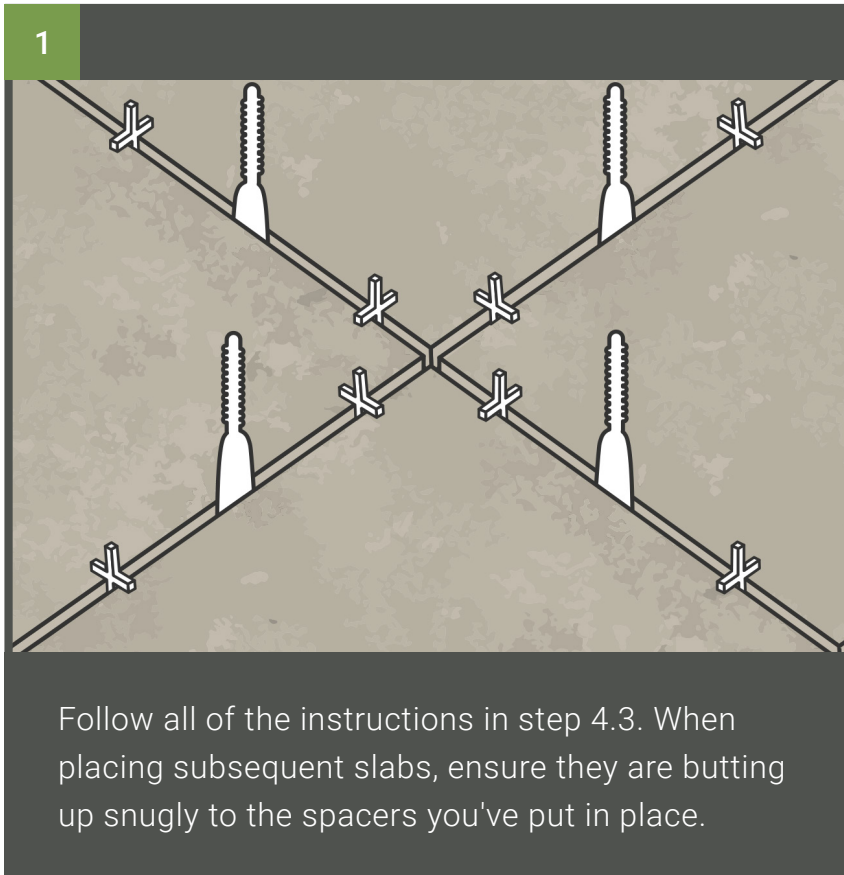

4.4 Laying subsequent slabs (continued)

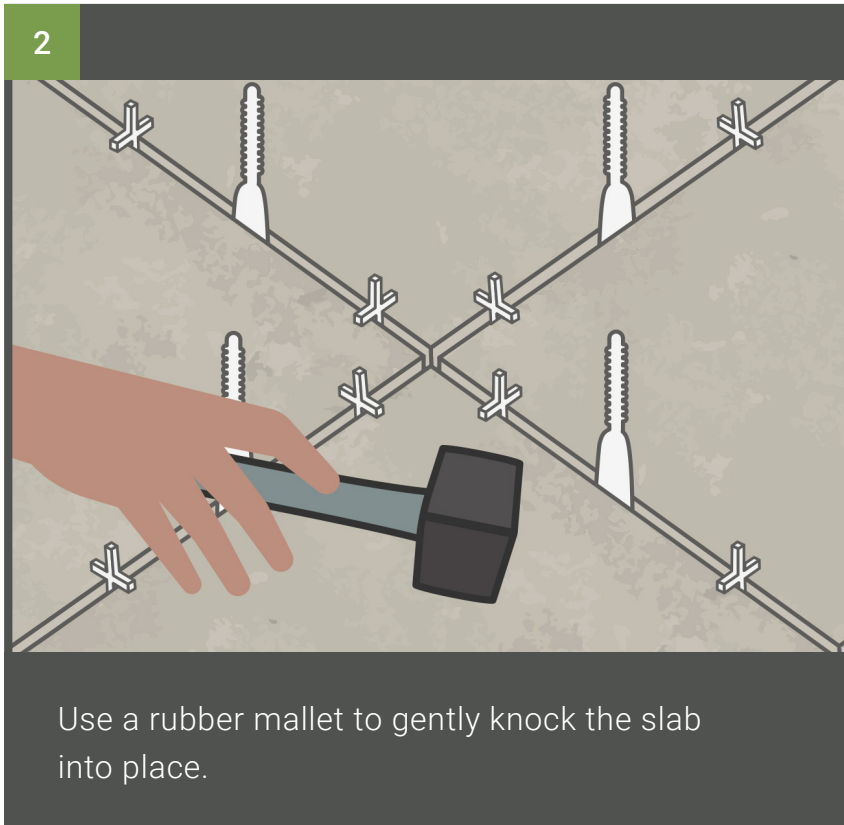

4.4 Laying subsequent slabs (continued)

3

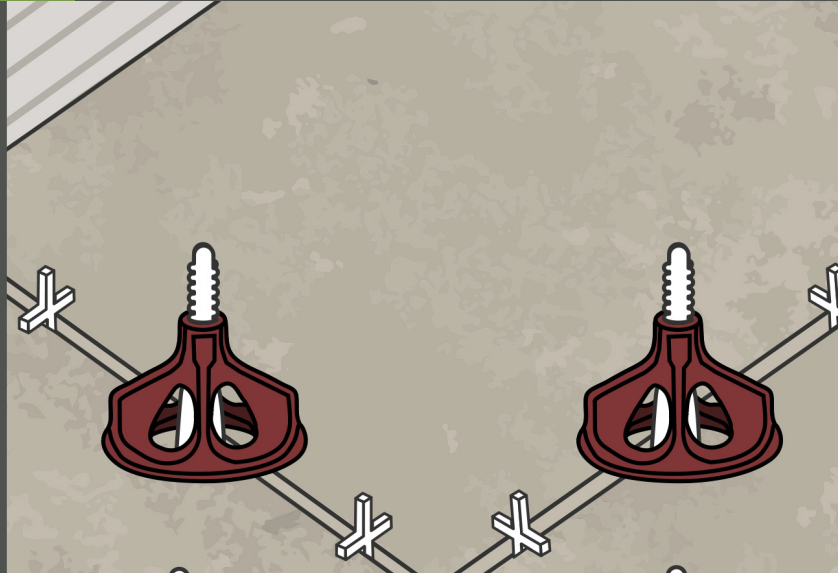

Thread a levelling cap onto each threaded spacer clip and tighten to ensure adjacent slabs are level.



We recommend using a **Raimondi VITA Landscaper Levelling Kit**, available from our store.

4.4 Laying subsequent slabs (continued)

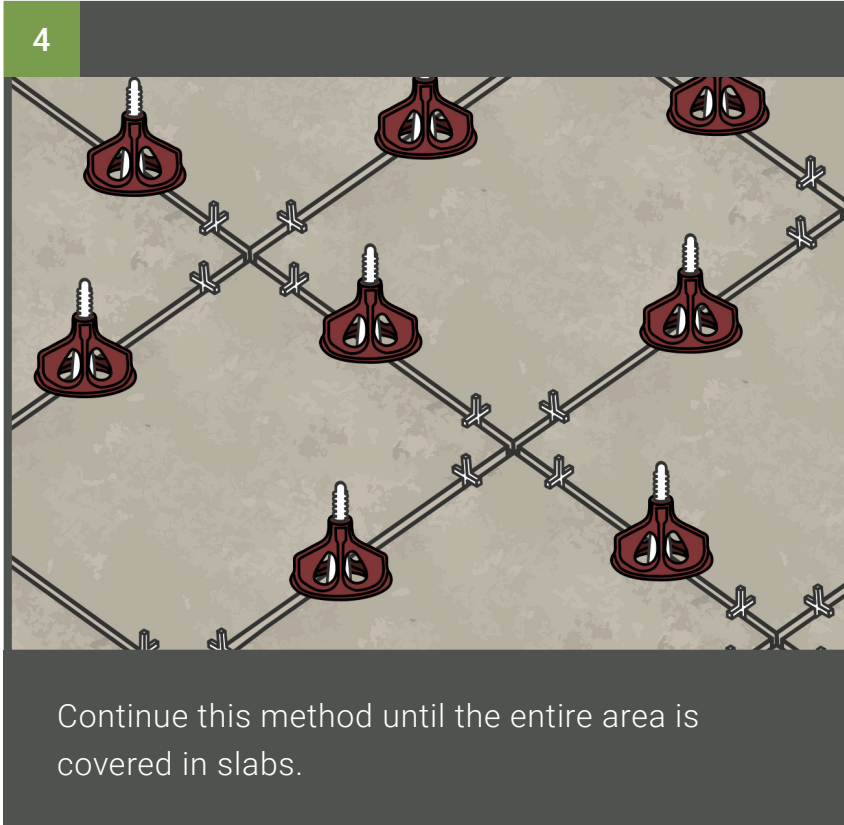

We recommend using a **Raimondi VITA Landscaper Levelling Kit**, available from our store.

4.4 Laying subsequent slabs (continued)

5

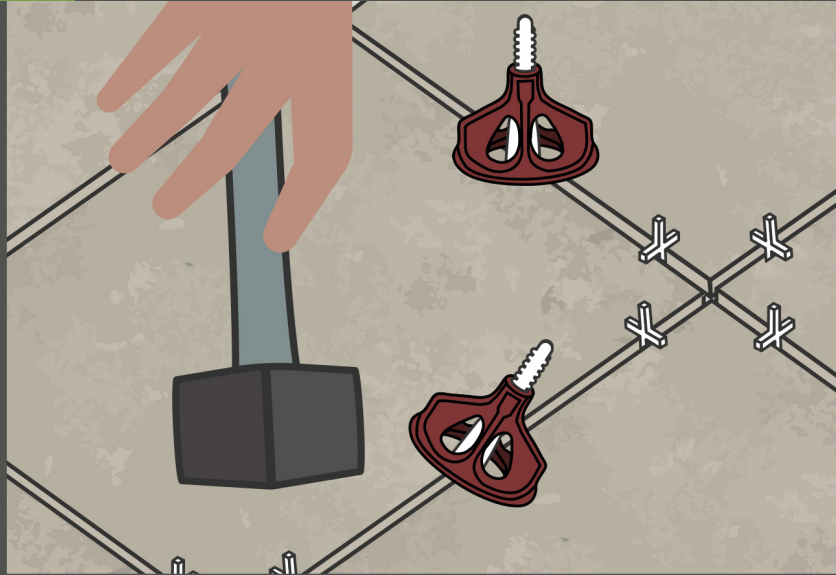

Once you are happy with the paved area, carefully snap off the levelling clips using a rubber mallet. Unscrew the caps from the levelling clips and keep for next time. Remove the "+"/"T" spacers.

4.5 Leave to set

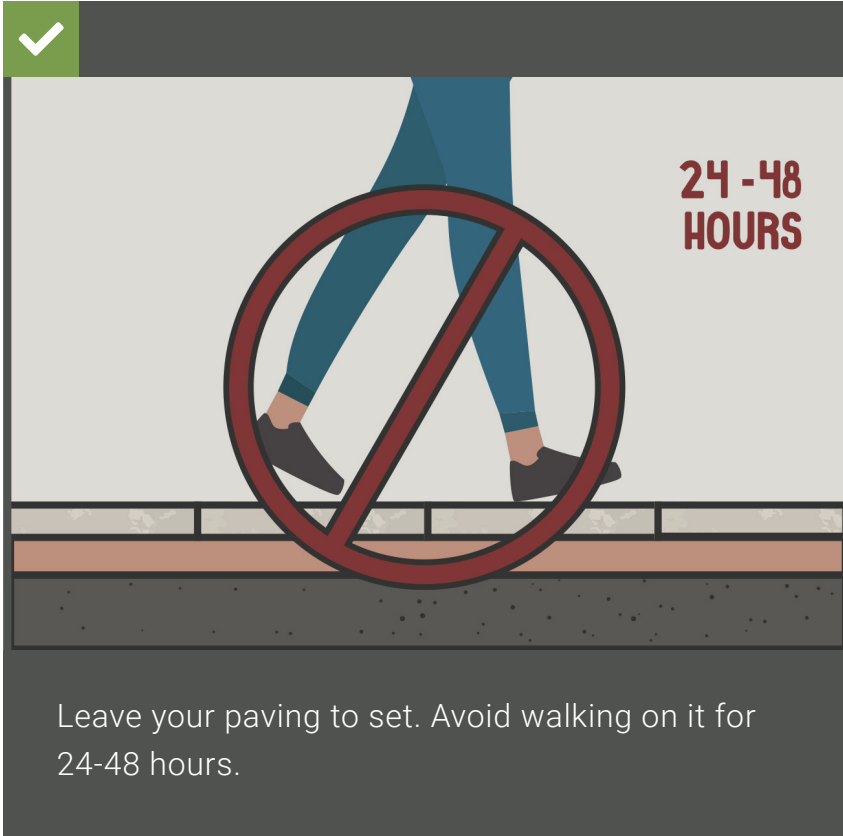

4.6 Applying grout

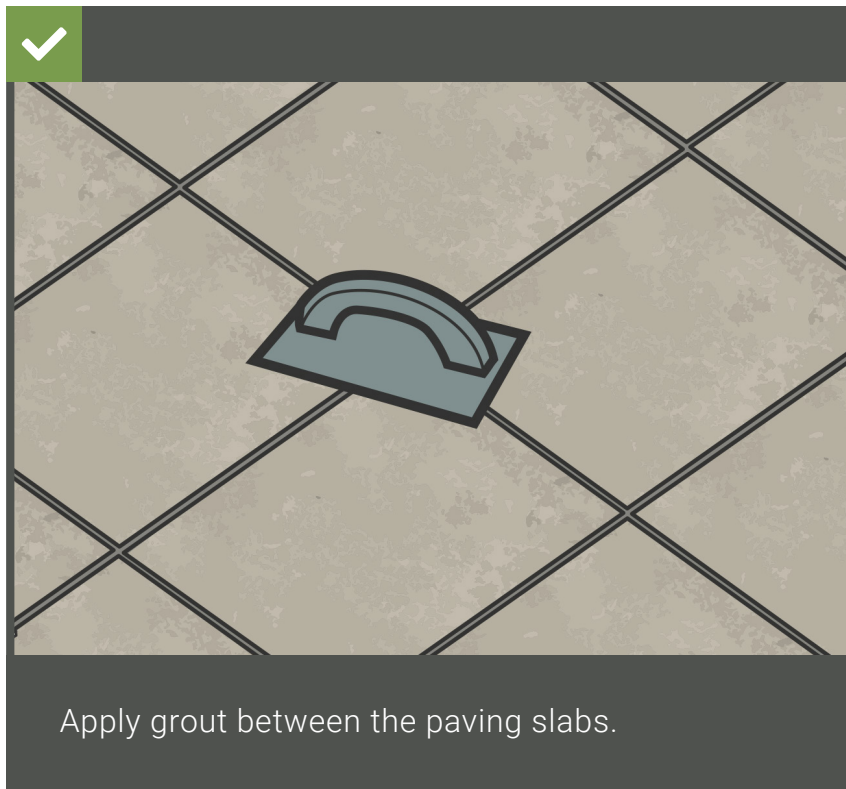

**BEFORE
GROUTING
YOU'LL NEED
TO ALLOW THE
MORTAR BED
TO CURE UP
TO 28 DAYS.**

Failure to do this can result in discolouring of grout and effervescence.



We recommend using **Fuga Pave Part C Flex CH Grout**. Follow the manufacturer's instructions.

TYPES OF GROUT/JOINTING COMPOUNDS WE SELL

Flowpoint Fine Flowable Grout

Flowable rapid setting grout specifically designed to give a tile grout finish. [Watch the how-to video.](#)

Premjoint High Spec Jointing Compound

Brush in jointing compound in fine granules. Premjoint should be laid on a permeable bed such a 6:1 sharp sand and cement mix. [Watch the how-to video.](#)

Fuga Pave Flex CH Grout

Flexible external tile grout. [Watch the how-to video.](#)

CARE AND SUPPORT

5. Maintenance

GENERAL CARE TIPS

Our products are designed to be low maintenance, but light cleaning and care can keep your porcelain paving looking brand new for longer.

CLEANING

A jet-wash is the most effective way to clean your porcelain tiles. A quick blast every now and then will be all the regular maintenance you should need. Should you find yourself with some tougher dirt, use a specific porcelain cleaner - but don't use brick acid!

