

M900PT, 8-inch Rugged Tablet

with MSR/ Smart Card Reader

Rugged Tablet that Can Survive Any Environment and Get Real Work Done

The M900PT is a compact rugged tablet with robust set of features designed to withstand industrial use while providing high tech solutions that increase productivity, improve safety, and reduce operational costs. The processing power comes from Intel's Apollo Lake processor paired with genuine Intel graphics for high performance. The tablet features a brilliant projective capacitive touch screen, which is outdoor viewable and offers 1280 x 800 pixel resolution. The M900PT features built-in MSR/ Smart Card Reader. Weighing at just 2.2 pounds (approx. 900 grams) the M900PT delivers lightweight mobility in a rugged tablet.



Highlights

- Intel® Pentium N4200 Apollo Lake processor
- 8" daylight readable panel with direct optical bonding
- Default D-sub for vehicle gateway connection
- Optional Barcode Reader

*Please consult your reseller or Winmate representative before purchasing.

*Accessories and Integrated Options may vary depending on your configuration. Visit Winmate website for more accessories and details.



M900PT, 8-inch Rugged Tablet

with MSR/ Smart Card Reader

Rugged Tablet that Can Survive Any Environment and Get Real Work Done

Display Specification

Size	8-inch
Resolution	1280x800
Panel Brightness	510 nit ¹
Touch	Multi touch projected capacitive
Contrast Ratio	800:1
Viewing Angle	85/85/85/85
Technology	<ul style="list-style-type: none">• Anti-reflective and anti-glare technology (Optional)• Ambient light sensor, e-compass, gyro, acceleration sensors• Automatic screen rotation• Intel HD Graphics (built-in CPU) video controller

System Specification

Processor	Intel® Pentium N4200 Processor 1.10 GHz, up to 2.50 GHz with turbo boost technology
System Memory	4 GB LPDDR4 ²
Storage	64 GB solid state drive (SSD), optional up to 512GB additional storage with microSDXC card slot
Operating System	Windows 10 IoT Enterprise (64 bit)

Wireless Communications

WLAN	802.11 a/b/g/n/ac
Bluetooth	Bluetooth 5.0
GNSS	GPS, GLONASS
WWAN	Optional 4G LTE

Interface

Docking Connector	1 x 19-pin docking connector
USB	1 x USB3.0 (Type-A), 1 x USB3.0 (Type-C) ³
Audio Connector	1 x Audio Combo connector (Mic in or Line Out)
Power Input	1 x Power Jack
Micro SD	1 x Micro SD Slot
D-sub	1 x 15-pin D-sub connector for Power Input, USB 2.0, Audio Out, and Tx/ Rx

Keyboard and Input

Buttons	<ul style="list-style-type: none">• On-screen QWERTY Keyboard• Buttons: 1 x Power, 1 x Home, 3 x function key (Programmable function key configured by Hottab Utility)
LED Indicators	Power, Battery, HDD, RF
Touch	10-point multi touch

Audio

Microphone	Built-in dual Digital Mic with Noise Cancellation
Speaker	2 x 1 Watt speaker

Camera

Front Camera	2MP Webcam
Rear Camera	8MP Rear Camera with Autofocus and LED Light

Data Capture

Barcode	1D/2D Barcode Reader (Optional)
MSR/ Smart Card Reader	Built-in MSR/ Smart Card Reader ISO 781017811

Security Function

Security	TPM v2.0, computrace ready (Optional)
Mobile Device Mgmt.	SOTI Mobicontrol compatible

Standards and Certification

EMC	CE, FCC, E-Mark
IoT	Microsoft Azure Certified for IoT

Mechanical and Environment

Dimensions	225 x 148 x 20.5 mm (10 x 7.76 x 0.8 inches) ⁴
Weight	0.9 kg with battery
Operating Temperature	-20°C to 60°C (AC mode), -10°C to 50°C (Battery mode)
Storage Temperature	-30°C to 70°C (-22°F to 158°F)
Humidity	10% to 90% RH, non-condensing
IP Rating	IP65 certified, dustproof and waterproof
Shock	MIL-STD-810G Method 516.6 Procedure I
Vibration	MIL-STD-810G Method 514.6 Procedure I
Drop	MIL-STD-810G Method 516.6, 5 ft to concrete

Power Management

Power Input	19V DC , 3.42A
Battery	7.6V, typ. 4200 mAh Li Polymer Battery (2S2P)
Battery Operating Time	8 hours ⁵
AC Adapter	100-240V, 50~60Hz

Accessories⁶

Standard Accessories

Adapter and Power Cord	922D065W19V1
Standard Battery Pack	98KA00000002

Optional Accessories

Desk Dock	98DA00000001
Vehicle Gateway	98DA00000003
Vehicle Cradle	98DA00000002
Battery Charger	98JA00000001
Carry Bag	9B000000003J
Hand Strap	98KA00000003
Capacitive Stylus	9B0000000415

Drawing⁷

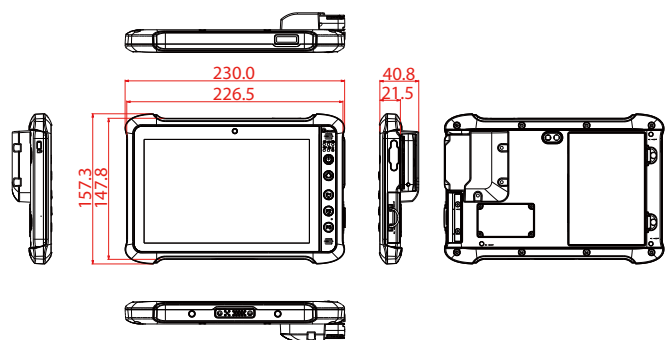

Do Not Expose the Battery Pack to Excessive Heat, or Extreme Heat (Near Fire, in Direct Sunlight for example)
Do not expose bare skin to this product when handling this unit in extreme hot or cold environments

1. Measured at dimming LCD brightness. Varies depending on the usage conditions, or when an external device is attached.
2. Total usable memory will be less depending upon actual system configuration.
3. The USB Type-C connector follows USB 3.0 standard, which does not support Alternate Mode (ALT) or USB Power Delivery (USB-PD).
4. Length measurements do not include protrusions. Weight varies with options.
5. Measured at dimming LCD brightness. Varies depending on the usage conditions, or when an external device is attached.
6. Accessories and Integrated Options may vary depending on your configuration.
7. This is a simplified drawing and some components are not marked in detail.