



120 or 180 Watts,  
24V Booster



## IFS-402GSM-4PH24

4x10/100Base-TX + 2x100/1000Base-X SFP with 4xPoE+

## IFS-803GSM-8PH24

8x10/100Base-TX + 3x100/1000Base-X SFP with 8xPoE+

The series models are managed industrial grade Ethernet PoE (Power over Ethernet) switches with 4/8 ports 10/100Base-TX PoE ports and 2/3 ports Fast/Gigabit Ethernet SFP ports that provide stable and reliable Ethernet transmission. With dual power input design, the series models can provide redundancy mechanism for critical applications that need always-on connections. These switches can also operate either at standard operating temperature range (-10 to 60°C) or at wide operating temperature range (-40 to 75°C) so as to fulfill the special needs of industrial automation applications. Housed in rugged DIN rail or wall mountable IP-30 enclosures, these switches are perfect choices for harsh environments, such as industrial networking, intelligent transportation systems (ITS) and are also suitable for many military and utility market applications where environmental conditions exceed commercial product specifications.

Apart from specially-designed outlook and hardware features, the Ethernet switches also support a wide variety of management functions, including STP/RSTP/MSTP/ ITU-T G.8032 Ring and multiple u-Ring for redundant cabling, advanced PoE management functions such as PoE device auto-checking and auto reset, PoE power on/off weekly scheduling, layer 2 Ethernet IGMP, VLAN, QoS, Security, IPv6, bandwidth control, port mirroring, cable diagnostics and Green Ethernet. Additionally, these switches can work with CTC Union's proprietary SmartView that offers user-friendly and centralized network management platform and provides to network administrators to monitor and configure these connected switches remotely.

### Features

- 4x 10/100Base-TX RJ-45+ 2x 100/1000Base-X SFP with 4x PoE+, total 120W power budget (IFS-402GSM-4PH24)
- 8x 10/100Base-TX RJ-45+ 3 x100/1000Base-X SFP with 8x PoE+, total 180W power budget (IFS-803GSM-8PH24)
- 24/48VDC redundant dual input power with built-in very high efficiency booster(94~97%) to rise up 55 VDC for PoE output
- Constant and regulated PoE output voltage at 55VDC
- Provides 4/8 port IEEE802.3af / 802.3at PoE output (30W per Port)
- Advanced PoE Management, PoE PD Failure Auto Checking and auto reset when PD fail, PoE port on/off weekly scheduling, PoE configuration for power planning
- UL60950-1, CE, FCC, Rail Traffic EN50121-4 certified
- Industrial grade EMS, EMI, EN61000-6-2, EN61000-6-4 certified
- Cable diagnostics, Measuring cable OK or broken point distance
- Supports Green Ethernet IEEE802.3az EEE (Energy Efficient Ethernet) management to optimize power consumption
- STP, RSTP, MSTP, ITU-T G.8032 Ethernet Ring Protection Switching (ERPS) for redundant cabling
- Provides 5 ring instances that each can support u-Ring, u-Chain or Sub-Ring type for flexible uses (Figure 3). Supports up to 5 rings in one device (Figure 2).
- u-Ring for Redundant Cabling, recovery time<10ms in 250 devices
- DHCP client/Relay/Snooping/Snooping option 82/Relay option 82
- QoS, Traffic classification QoS, CoS, bandwidth control for Ingress and Egress, Storm Control, DiffServ
- IEEE802.1q VLAN, MAC based VLAN, IP subnet based VLAN, Protocol based VLAN, VLAN translation, GVRP, MVR
- Dynamic IEEE 802.3ad LACP Link Aggregation, Static Link Aggregation
- IGMP snooping V1/V2/V3, IGMP Filtering/ Throttling, IGMP query, IGMP proxy reporting, MLD snooping V1/V2
- Flexibility security: Port based and MAC based IEEE802.1X, RADIUS, ACL, TACACS+, HTTP/HTTPS, SSL/SSH v2
- Software upgrade via TFTP and HTTP, redundant firmware to avoid upgrade failure
- Support IEEE1588 PTP V2 for precise time synchronization to operate in Master, Boundary, Slave mode by each port
- RMON, MIB II, Port mirroring, Event syslog, DNS, NTP/SNTP, IEEE802.1ab LLDP
- Supports IPv6 Telnet server /ICMP v6
- CLI, Web based management, SNMP v1/v2c/v3, Telnet server for management
- Provides SmartConfig for quick and easy mass configuration
- Supports SmartView for centralized management

### Specifications

<b>Standard</b>	IEEE 802.3	10Base-T 10Mbit/s Ethernet	<b>Switch Architecture</b>	Back-plane (Switching Fabric): 4.8Gbps (IFS-402GSM-4PH24) 7.6Gbps (IFS-803GSM-8PH24)
	IEEE 802.3u	100Base-TX, 100Base-FX, Fast Ethernet	<b>Data Processing</b>	Store and Forward
	IEEE 802.3ab	1000Base-T Gbit/s Ethernet over twisted pair	<b>Flow Control</b>	IEEE 802.3x for full duplex mode Back pressure for half duplex mode
	IEEE 802.3z	1000Base-X Gbit/s Ethernet over Fiber-Optic	<b>Network Connector</b>	4x 10/100Base-TX RJ-45 + 2x 100/1000Base-X SFP connector (IFS-402GSM-4PH24) 8x 10/100Base-TX RJ-45 + 3x 100/1000Base-X SFP connector (IFS-803GSM-8PH24) RJ-45 UTP port support Auto negotiation speed, Auto MDI/MDI-X function, SFP port support 100/1000 dual speed with DDMI
	IEEE 802.3af	PoE (Power over Ethernet)	<b>Console</b>	RS-232 (RJ-45)
	IEEE 802.3at	PoE+ (Power over Ethernet enhancements)	<b>PoE RJ-45 Pin Assignment</b>	4x IEEE 802.3af /IEEE 802.3at PoE+ (IFS-402GSM-4PH24) 8x IEEE 802.3af /IEEE 802.3at PoE+ (IFS-803GSM-8PH24) End-Span, Alternative A mode. Positive (V+): RJ-45 pin 1, 2. Negative (V-): RJ-45 pin 3, 6. Data (1,2,3,6)
	IEEE 802.1d	STP (Spanning Tree Protocol)	<b>Network Cable</b>	UTP/STP above Cat. 5e cable EIA/TIA-568 100-ohm (100m)
	IEEE 802.1w	RSTP (Rapid Spanning Tree Protocol)	<b>Protocols</b>	CSMA/CD
	IEEE 802.1s	MSTP (Multiple Spanning Tree Protocol)	<b>Reverse Polarity Protection</b>	Present
	ITU-T G.8032 / Y.1344	ERPS (Ethernet Ring Protection Switching)		
	IEEE 802.1Q	Virtual LANs (VLAN)		
	IEEE 802.1X	Port based and MAC based Network Access Control, Authentication		
	IEEE 802.3ad	Link aggregation for parallel links with LACP(Link Aggregation Control Protocol)		
	IEEE 802.3x	Flow control for Full Duplex		
	IEEE 802.1ad	Stacked VLANs, Q-in-Q		
	IEEE 802.1p	LAN Layer 2 QoS/CoS Protocol for Traffic Prioritization		
	IEEE 802.1ab	Link Layer Discovery Protocol (LLDP)		
	IEEE 802.3az	EEE (Energy Efficient Ethernet)		

<b>Overload Current Protection</b>	Present														
<b>CPU Watch Dog</b>	Present														
<b>Power Supply</b>	Redundant Dual DC 24/48V (20~57VDC) Input power (Removable Terminal Block) Built-in very high efficiency booster(94~97%) to rise up 55 VDC for PoE output														
<b>Power Consumption</b>	<b>IFS-402GSM-4PH24 Power consumption &amp; Booser efficiency</b>														
	<table border="1"> <thead> <tr> <th>Input Voltage</th> <th>Total Power Consumption</th> <th>Device Power Consumption</th> <th>PoE Budget</th> <th>Boost Efficiency</th> </tr> </thead> <tbody> <tr> <td>24VDC</td> <td>134.8W</td> <td>7.1W</td> <td>120W</td> <td>94.0%</td> </tr> <tr> <td>48VDC</td> <td>132.2W</td> <td>8.5W</td> <td>120W</td> <td>97.2%</td> </tr> </tbody> </table>	Input Voltage	Total Power Consumption	Device Power Consumption	PoE Budget	Boost Efficiency	24VDC	134.8W	7.1W	120W	94.0%	48VDC	132.2W	8.5W	120W
Input Voltage	Total Power Consumption	Device Power Consumption	PoE Budget	Boost Efficiency											
24VDC	134.8W	7.1W	120W	94.0%											
48VDC	132.2W	8.5W	120W	97.2%											
	<b>IFS-803GSM-8PH24 Power consumption &amp; Booser efficiency</b>														
	<table border="1"> <thead> <tr> <th>Input Voltage</th> <th>Total Power Consumption</th> <th>Device Power Consumption</th> <th>PoE Budget</th> <th>Boost Efficiency</th> </tr> </thead> <tbody> <tr> <td>24VDC</td> <td>198.3W</td> <td>7.3W</td> <td>180W</td> <td>94%</td> </tr> <tr> <td>48VDC</td> <td>193.2W</td> <td>7.9W</td> <td>180W</td> <td>97%</td> </tr> </tbody> </table>	Input Voltage	Total Power Consumption	Device Power Consumption	PoE Budget	Boost Efficiency	24VDC	198.3W	7.3W	180W	94%	48VDC	193.2W	7.9W	180W
Input Voltage	Total Power Consumption	Device Power Consumption	PoE Budget	Boost Efficiency											
24VDC	198.3W	7.3W	180W	94%											
48VDC	193.2W	7.9W	180W	97%											
<b>LED</b>	Per unit: Power 1 (Green), Power 2 (Green), Fault (Amber), CPU Act (Green), Ring Master (Yellow) Per RJ-45 port: Link/Active (Green) SFP Fiber Per port: Link/Active (Green) PoE Port LED 1 LED /per Port : <ul style="list-style-type: none"> <li>PoE Output Power On : ON (Green)</li> <li>PoE Fault (Over Load, Short Circuit,Port failed at Startup) : Flash 1times /sec (Green)</li> <li>PoE Output Power Off : Off</li> </ul>														
<b>Jumbo Frame</b>	9.6KB														
<b>MAC Address Table</b>	8K														
<b>Memory Buffer</b>	256K Bytes for packet buffer														
<b>Warning Message</b>	System Syslog, SMTP/ e-mail event message, alarm relay														
<b>Alarm Relay Contact</b>	Relay outputs with current carrying capacity of 1 A @24VDC														
<b>Removable Terminal Block</b>	Provide 2 redundant power, alarm relay contact, 6 Pin														
<b>Operating Temperature</b>	-10 ~ 60°C (IFS-402GSM-4PH24, IFS-803GSM-8PH24) -40 ~ 75°C (IFS-402GSM-4PHE24, IFS-803GSM-8PHE24)														
<b>Operating Humidity</b>	5% to 95% (Non-condensing)														

## Software Specifications

<b>Topology</b>	
<b>VLAN</b>	IEEE 802.1q VLAN, up to 4094 802.1Q VLAN VID IEEE 802.1q VLAN, up to 4094 Groups IEEE 802.1ad Q-in-Q MAC-based VLAN, up to 256 entries IP Subnet-based VLAN, up to 128 entries Protocol-based VLAN(Ethernt, SNAP, LLC), up to 128 entries VLAN Translation, up to 256 entries GVRP (GARP VLAN Registration Protocol) MVR ( Multicast VLAN Registration )
<b>Link Aggregation (Port Trunk)</b>	Static (Hash with SA, DA, IP, TCP/UDP port), up to 5 trunk group Dynamic (IEEE 802.3ad LACP), up to 5 trunk group
<b>Spanning Tree</b>	IEEE802.1d STP IEEE802.1w RSTP IEEE802.1s MSTP
<b>Multiple u-Ring</b>	up to 5 instances that each supports u-Ring, u-Chain or Sub-Ring type for flexible uses, and maximum up to 5 Rings (Figure 2,3,4,5). Recovery time <10ms The maximum number of devices allowed in a Ring supported ring is 250.
<b>Loop Protection</b>	Present
<b>ITU-T G.8032 / Y.1344 ERPS (Ethernet Ring Protection)</b>	Recovery time <50ms Single Ring, Sub-Ring, Multiple ring topology network
<b>QoS Features</b>	
<b>Class of Service</b>	IEEE802.1p 8 active priorities queues for per port
<b>Traffic Classification QoS</b>	IEEE802.1p based CoS IP Precedence based CoS IP DSCP based CoS QCL(QoS Control List): Frame Type, Source/ Destination MAC, VLAN ID, PCP, DEI QCE(QoS Control Entry): Protocol, Source IP, IP Fragment, DSCP, TCP/UDP port number
<b>Bandwidth Control for Ingress</b>	Rate in steps :1 kbps / Mbps / fps / kfps Range : 100 kbps to 1Gbps / 1fps to 3300kfps Rate Unit : bit or frame

<b>Storage Temperature</b>	-40 ~ 85°C
<b>Housing</b>	Rugged Metal, IP30 Protection, Fanless
<b>Dimensions</b>	106 x 62.5 x 135 mm (D x W x H) (IFS-402GSM-4PH24) 106 x 72 x 152 mm (D x W x H) (IFS-803GSM-8PH24)
<b>Weight</b>	0.715kg (IFS-402GSM-4PH24) 0.96kg (IFS-803GSM-8PH24)
<b>Installation Mounting</b>	DIN Rail mounting or wall mounting
<b>MTBF</b>	276,161Hrs (IFS-402GSM-4PH24) 314,064Hrs (IFS-803GSM-8PH24) (MIL-HDBK-217)
<b>Warranty</b>	5 years
<b>Certification</b>	
<b>EMC</b>	CE
<b>EMI (Electromagnetic Interference)</b>	FCC Part 15 Subpart B Class A, CE EN55022 Class A
<b>Railway Traffic</b>	EN50121-4
<b>Immunity for Heavy Industrial Environment</b>	EN61000-6-2
<b>Emission for Heavy Industrial Environment</b>	EN61000-6-4
<b>EMS (Electromagnetic Susceptibility) Protection Level</b>	EN61000-4-2 (ESD) Level 3, Criteria B EN61000-4-3 (RS) Level 3, Criteria A EN61000-4-4 (Burst) Level 3, Criteria A EN61000-4-5 (Surge) Level 3, Criteria B EN61000-4-6 (CS) Level 3, Criteria A EN61000-4-8 (PFMF, Magnetic Field) Field Strength: 300A/m, Criteria A
<b>Safety</b>	UL60950-1
<b>Shock</b>	IEC 60068-2-27
<b>Freefall</b>	IEC 60068-2-32
<b>Vibration</b>	IEC 60068-2-6

<b>Bandwidth Control for Egress</b>	Rate in steps : 1 kbps / Mbps Range : 100 kbps to 1Gbps Rate Unit : bit Per queue / Per port shaper
<b>DiffServ (RF 2474) Remarking</b>	
<b>Storm Control</b>	for Unicast, Broadcast, Multicast
<b>IP Multicasting Features</b>	
<b>IGMP / MLD Snooping</b>	IGMP Snooping v1, v2, v3 / MLD Snooping v1, v2 Port Filtering Profile Throttling Fast Leave Maximum Multicast Group : up to 1022 entries Query / Static Router Port
<b>Security Features</b>	
<b>IEEE 802.1X</b>	Port-Based MAC-Based
<b>ACL</b>	Number of rules : up to 256 entries for L2 / L3 / L4
<b>RADIUS authentication &amp; accounting</b>	
<b>TACACS+ authentication &amp; accounting, TACACS+ 3.0</b>	
<b>HTTPS, HTTP</b>	
<b>SSL / SSH v2</b>	
<b>User Name Password Authentication</b>	Local Authentication Remote Authentication (via RADIUS / TACACS+)
<b>Management Interface Access Filtering</b>	Web, Telnet / SSH , CLI RS-232 console
<b>Management Features</b>	
<b>CLI</b>	Cisco® like CLI
<b>Web Based Management</b>	
<b>Telnet</b>	Server
<b>SNMP</b>	V1, V2c, V3
<b>SW &amp; Configuration Upgrade</b>	TFTP, HTTP Redundant firmware in case of upgrade failure
<b>RMON</b>	RMON I (1, 2, 3, 9 group), RMON II
<b>MIB</b>	RFC1213 MIB II, Private MIB

DHCP	Client Relay Snooping Snooping option 82 Relay option 82
IP Source Guard	
Port Mirroring	
Event Syslog	Syslog server (RFC3164) (Support 1 server)
Warning Message	System syslog, e-mail, alarm relay
DNS	Client, Proxy
IEEE1588 PTP V2	Master, Boundary, Slave Operating mode Operating in each port of these switch
NTP / SNTP	
LLDP (IEEE 802.1ab)	Link Layer Discovery Protocol LLDP-MED
<b>IPv6 Features</b>	
IPv6 Management	Telnet Server/ICMP v6
SNMP over IPv6	
HTTP over IPv6	
SSH over IPv6	
IPv6 Telnet Support	
IPv6 NTP / SNTP Support	

IPv6 TFTP Support	
IPv6 QoS	
IPv6 ACL	Number of rules: up to 256 entries L2 / L3 / L4
<b>Others Features</b>	
Green Ethernet	Supports IEEE802.3az EEE (Energy Efficient Ethernet) Management to optimize the power consumption Determine the cable length and lowering the power for ports with short cables
Green Ethernet	Lower the power for a port when there is no link LED Power Management :Adjustment LEDs intensity
Cable Diagnostic	Measuring cable normal or broken point distance
<b>Advanced PoE Management</b>	
	PoE PD failure auto checking ,and auto reset when PD fail PoE port on/off weekly scheduling PoE Configuration PoE Enable/Disable Power limit by classification Power limit by management Total PoE Power budget limitation (maximum 120W for IFS-402GSM-4PH24 ,180W for IFS-803GSM-8PH24) Power feeding priority

## Application

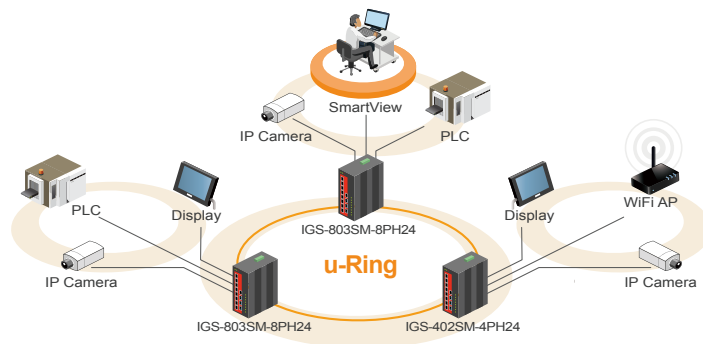

Figure 1 : Application Example

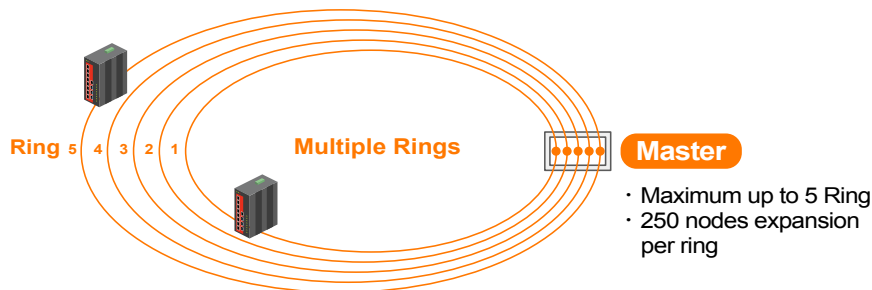

Figure 2 : Multiple Ring

u-Ring Configuration							
Delete	Instance	Type	Master	East		West	
				Port	Edge	Port	Edge
Delete	1	u-Ring	<input type="checkbox"/>	1		2	
Delete	2	u-Ring	<input type="checkbox"/>	4		3	
Delete	3	u-Ring	<input type="checkbox"/>	10 (Fiber2)		11 (Fiber3)	
Delete	4	Sub-Ring	<input type="checkbox"/>	6			
Delete	5	u-Chain	<input type="checkbox"/>	5	<input type="checkbox"/>	9 (Fiber1)	<input type="checkbox"/>

Figure 3 : An illustration of u-Ring instances configured in Web interface

Figure 4 : u-Ring Type

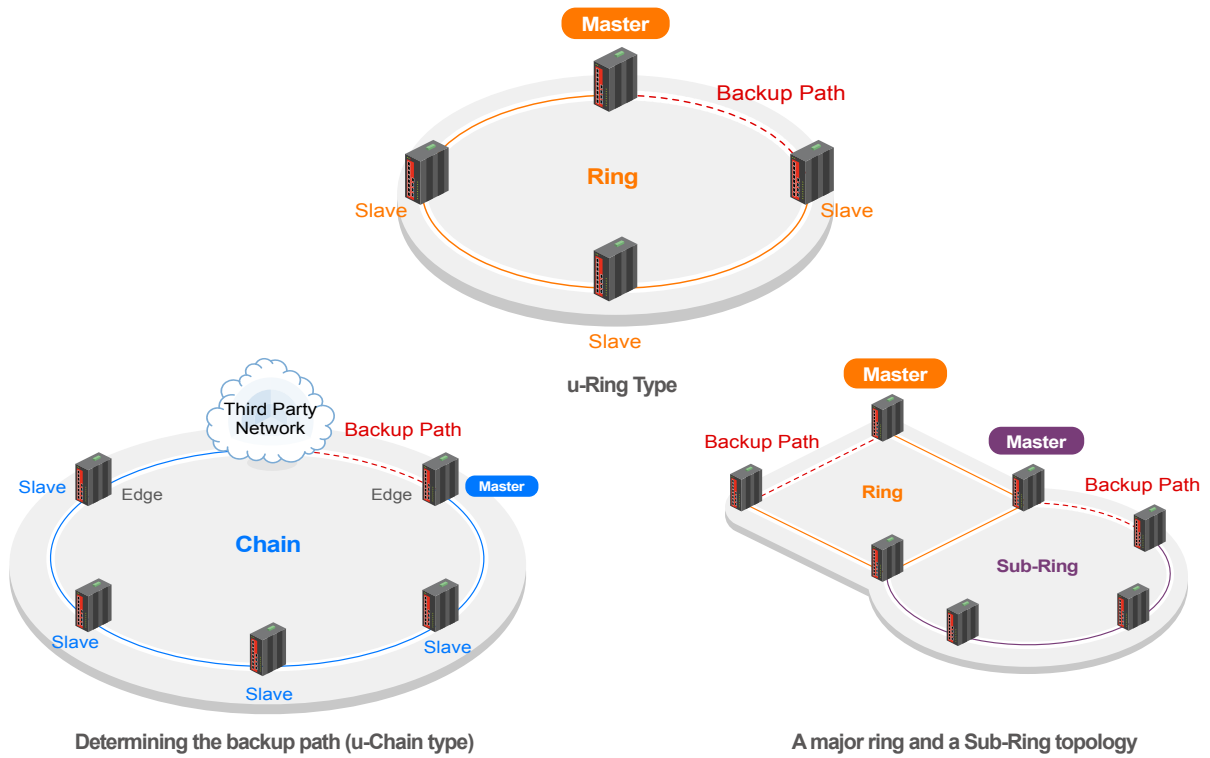
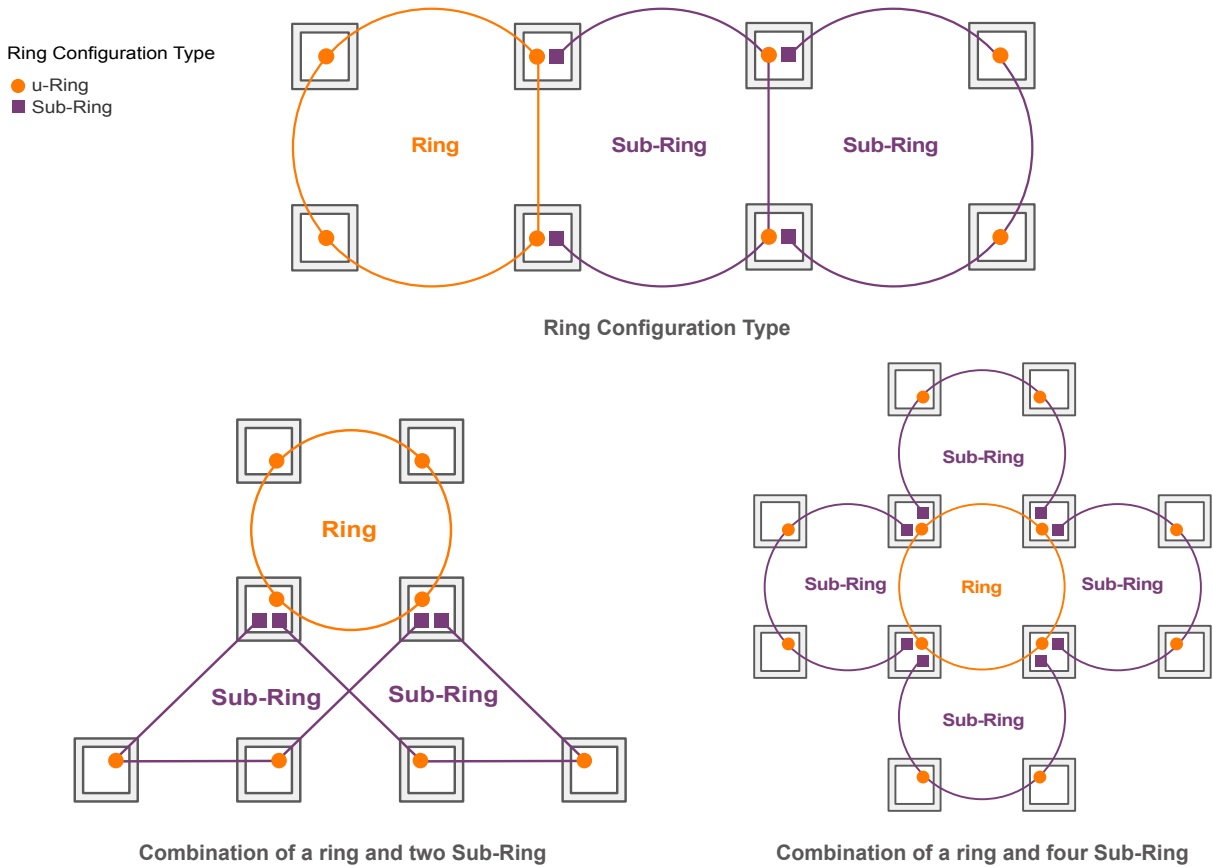
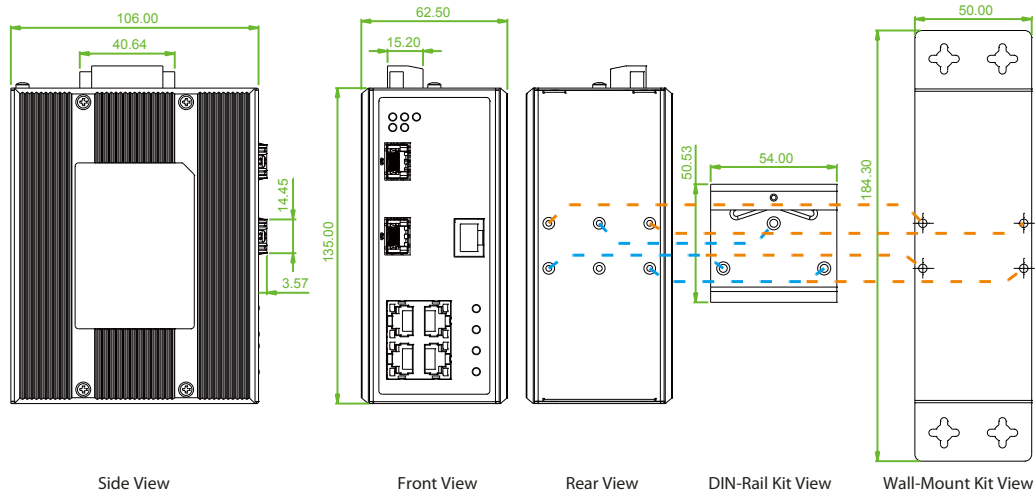

Figure 5 : Ring Configuration Example



## Dimensions

### IFS-402GSM-4PH24



### IFS-803GSM-8PH24

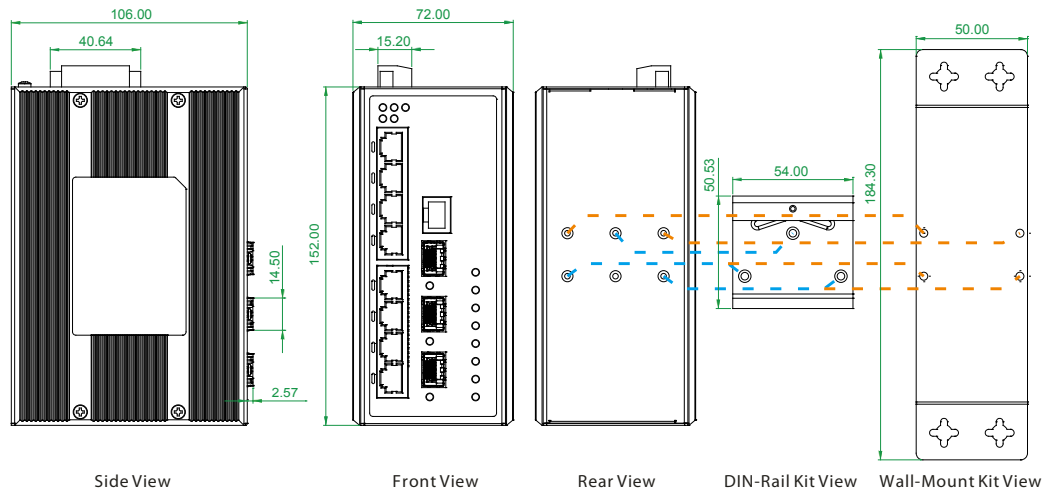

## Ordering Information

Model Name	Managed	Total Port	UTP		Fiber	PoE Port		Certification			Operating Temperature
			10/100 Base-TX	100/1000 Base-X	IEEE 802.3at	Power Budget	Railway EN50121-4	Safety UL60950-1	EN61000-6-2 EN61000-6-4	CE, FCC	
IFS-402GSM-4PH24	V	6	4	2 SFP	4	120W	V	V	V	V	-10~60°C
IFS-402GSM-4PHE24	V	6	4	2 SFP	4	120W	V	V	V	V	-40~75°C
IFS-803GSM-8PH24	V	11	8	3 SFP	8	180W	V	V	V	V	-10~60°C
IFS-803GSM-8PHE24	V	11	8	3 SFP	8	180W	V	V	V	V	-40~75°C

### Model Naming Rule

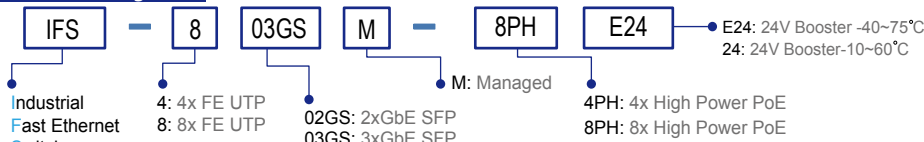

### Accessories

<b>DR-120-24</b>	Industrial Power, Input 88 ~ 132VAC / 176 ~ 264VAC, Output 24VDC, 120W, -10 ~ +60°C
<b>DRP-240-48</b>	Industrial Power, Input 85 ~ 264VAC, Output 48VDC, 240W, -10 ~ +70°C
<b>SFP Transceiver</b>	Compatible, Reliable, 5-year Warranty

### SFP Naming Rule

