

# **SIM LAB**

## INSTRUCTION MANUAL

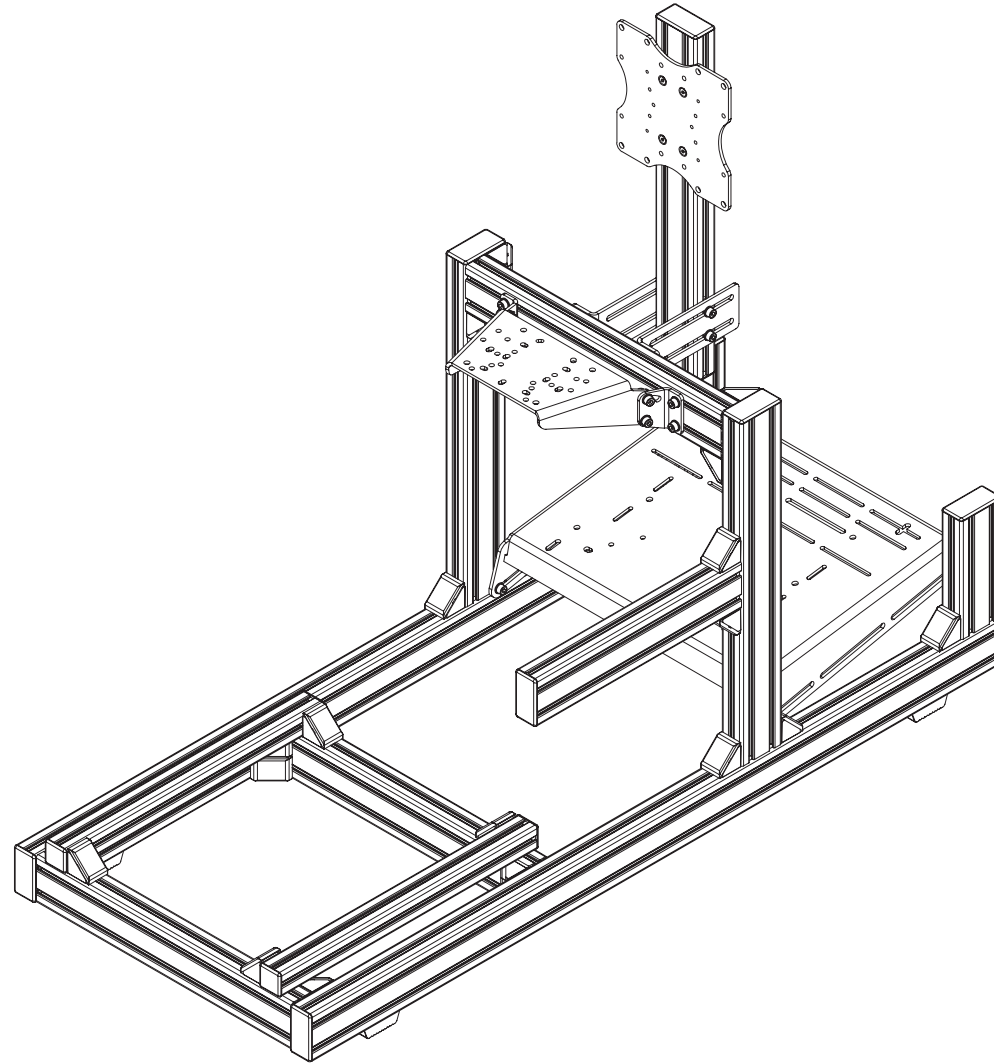

### **GT1 Evo 2 Rig Bundle**

**VERSION 1.0**

Last updated: 05-12-2023

# BEFORE YOU START:

Thank you for purchasing this Sim-Lab product! For our valued Micro Center customers, we combined some manuals for you. Each self contained manual is now represented in this document, maintaining its own page numbering and bill of materials (BOM).

All references to pages and notes to the manuals still apply and we urge you to read through the 'before you start' and BOM pages of these to make sure you have all tools and parts needed to follow along.

Here are the tools required just to give you a head start.

GT1-EVO tools required:

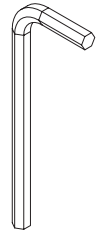

5/6MM

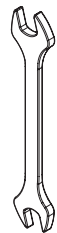

13MM



—

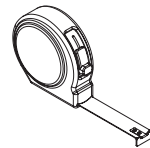
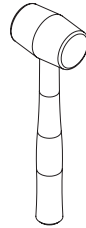

GT1-EVO Screen holder tools required:

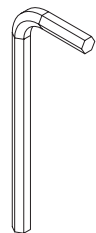

4/5/6MM

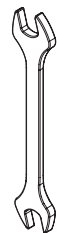

7MM



+

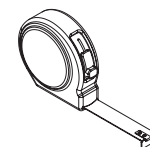
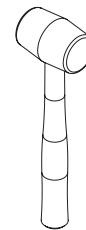

# **SIM LAB**

## INSTRUCTION MANUAL

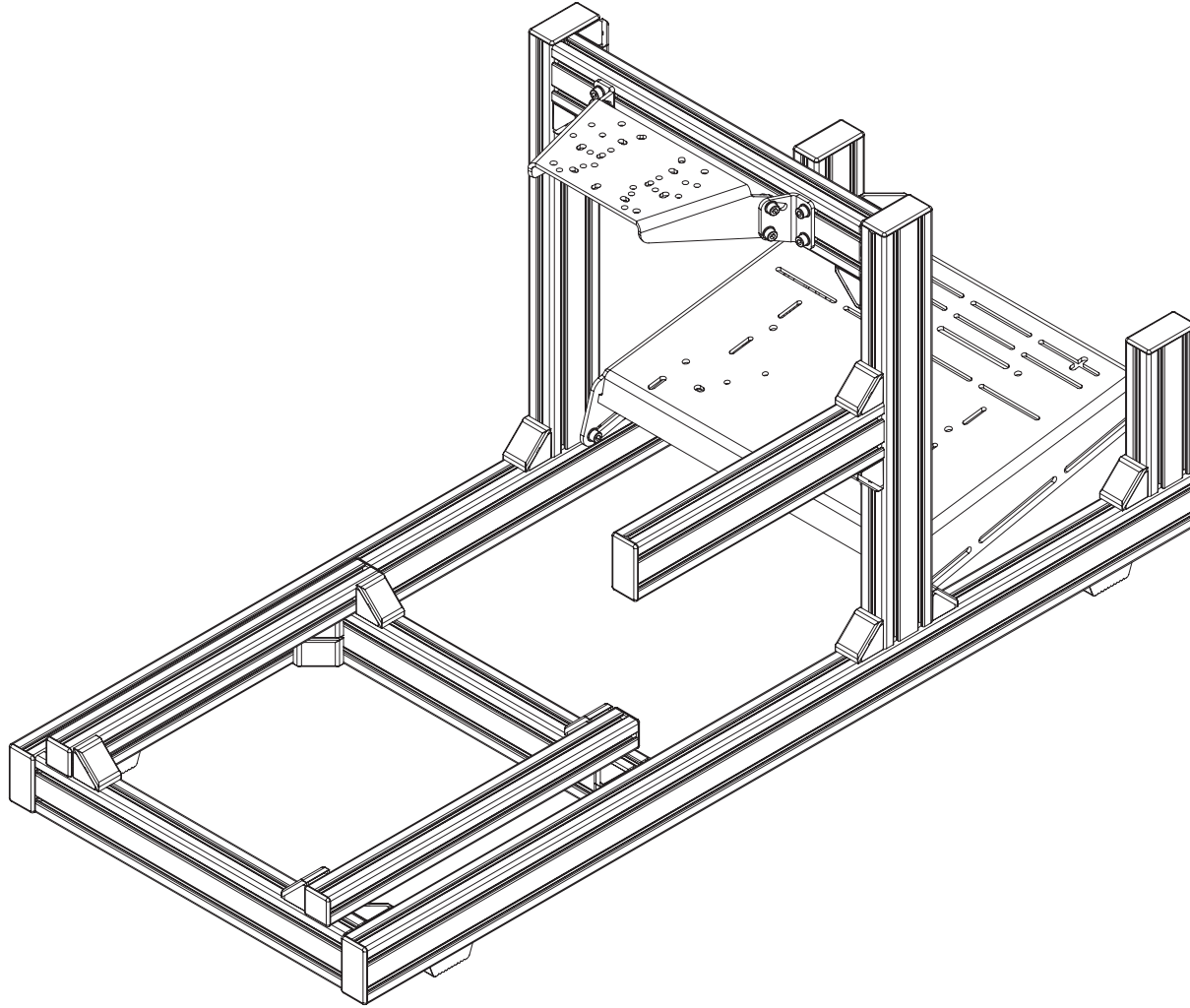

**GT1-EVO**  
**VERSION 3.0**  
Last updated: 20-10-2023

# BEFORE YOU START:

Thank you for purchasing this Sim-Lab product! On the following pages, you will find detailed instructions on assembly. This requires only a set of simple tools and some of your time. Please check the bill of materials before starting (page 22) and make sure all the parts are delivered.

## Inserting Slot-Nuts:

You got excited, finished the build, put the caps on, but forgot to install one element. Do not worry. It happens to everyone. In this diagram, you can see how to insert a Slot-Nut directly into the slot from the side. You can also use one of your smaller Hex wrenches to help wiggle the Slot-Nut in place.

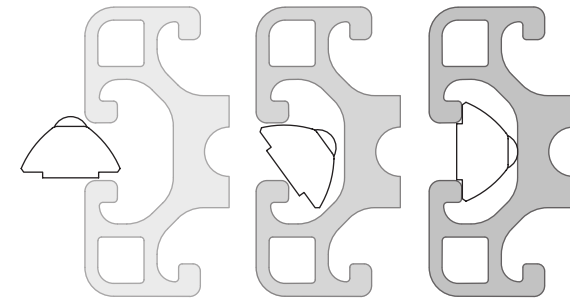

## Breaking tabs:

Sometimes tabs from corner brackets need to be broken off in order to fit as instructed. Place a flathead screwdriver behind the tab and tilt upwards.

Always make sure to point away from you while doing so. To know when to do this, we will show the following symbol  next to the brackets.

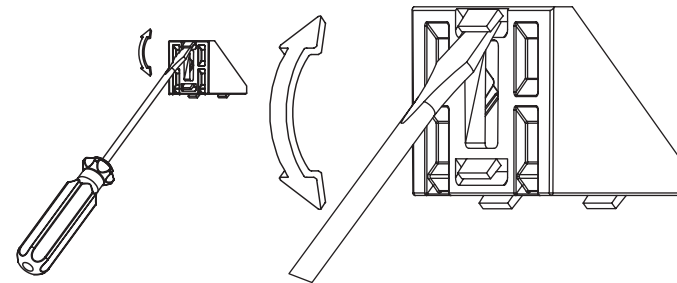

## Tools needed:

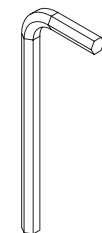

5/6MM



13MM



—

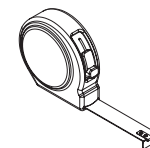
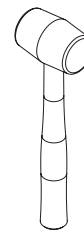

1350MM

Slot-Nut M8

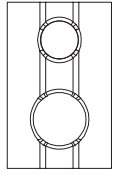
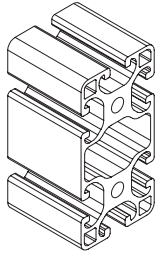

1X

4X

BUILD 2X

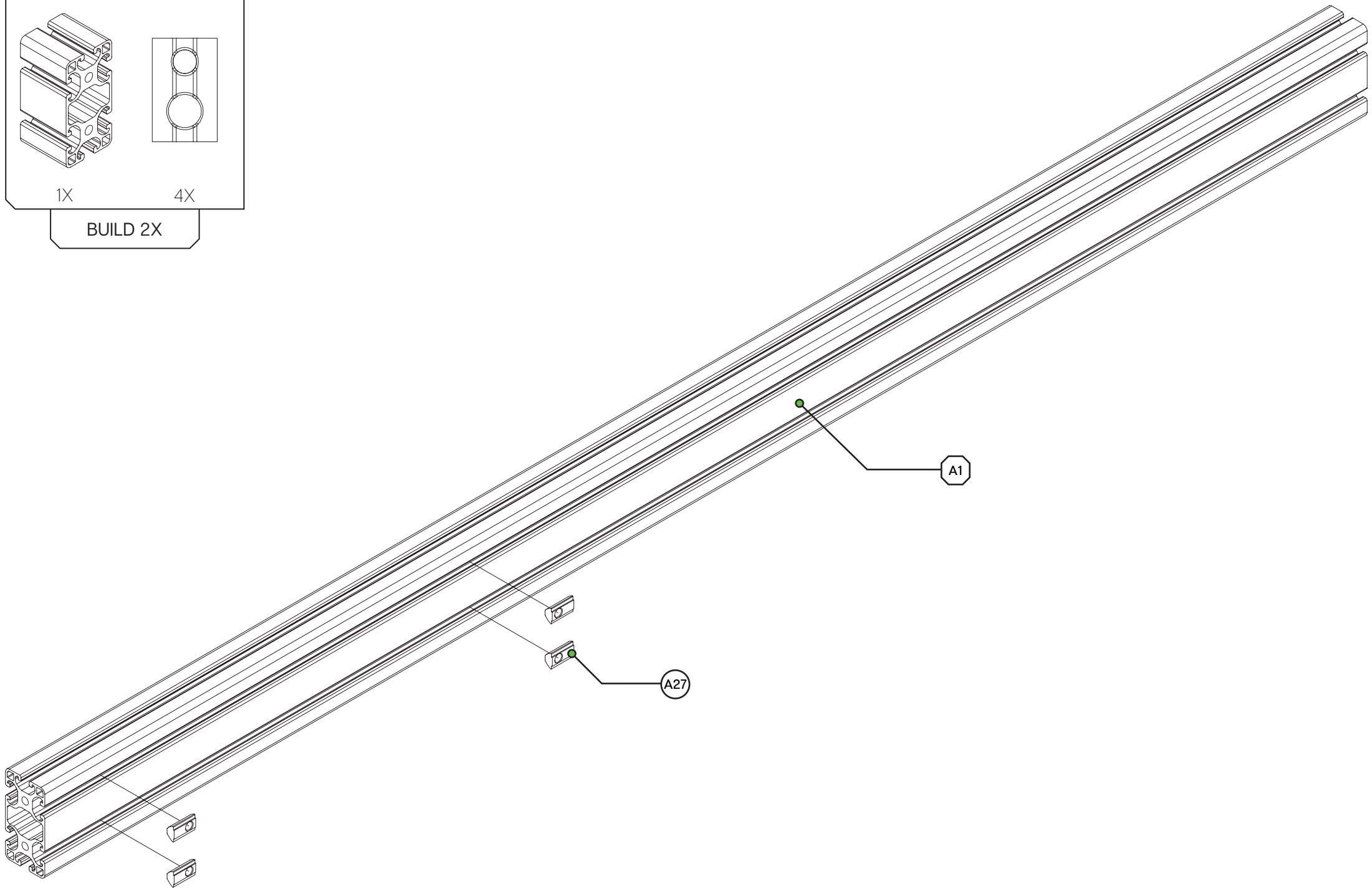

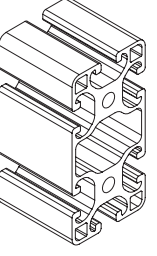
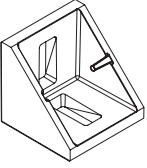
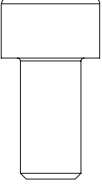
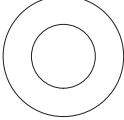
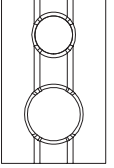
500MM	Corner Bracket	M8 X 16	Washer M8	Slot-Nut M8
				
1X	4X	4X	4X	4X
<b>BUILD 2X</b>				

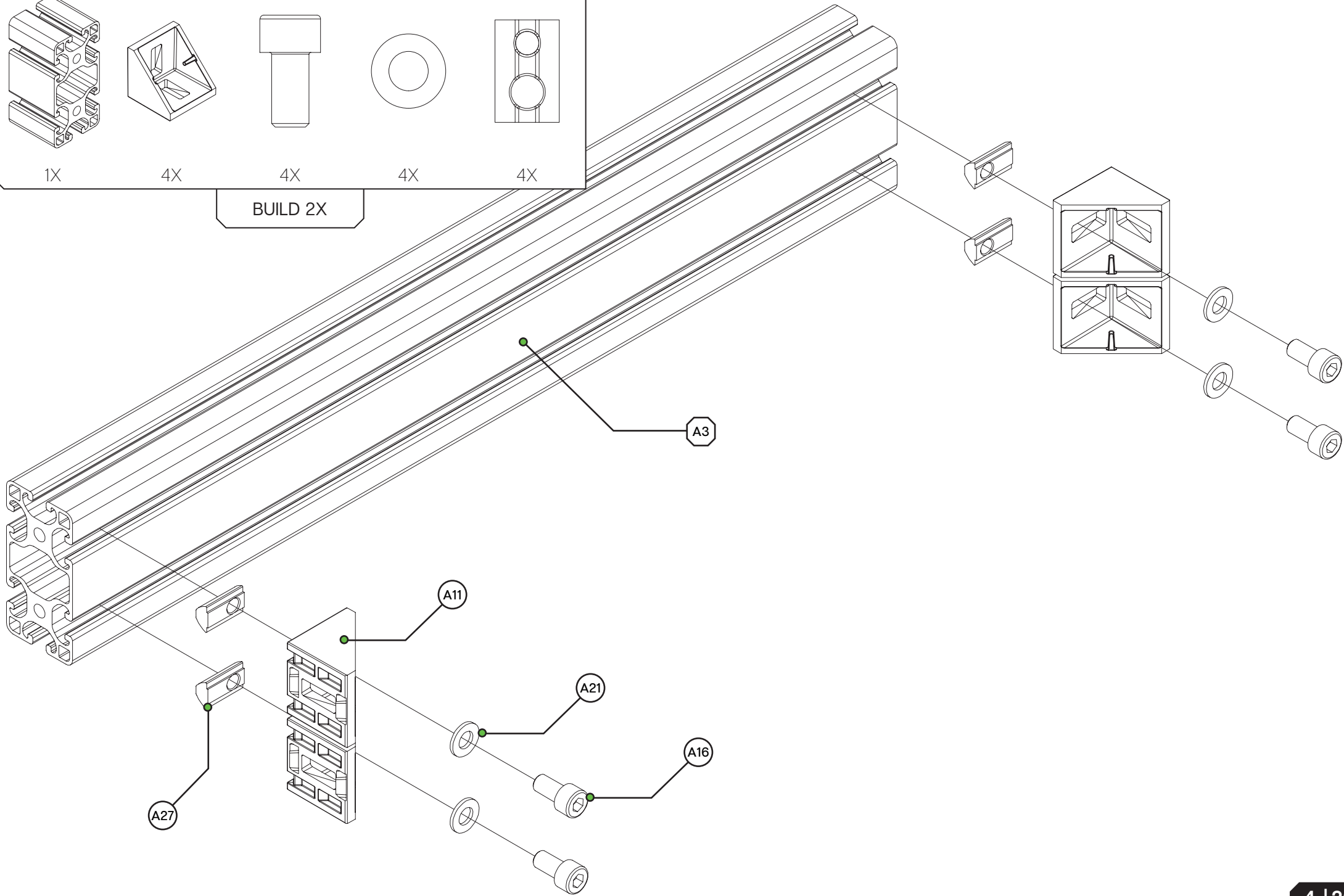

M8 X 16

Washer M8

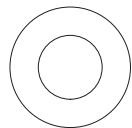
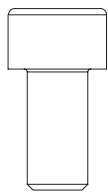

8X

8X

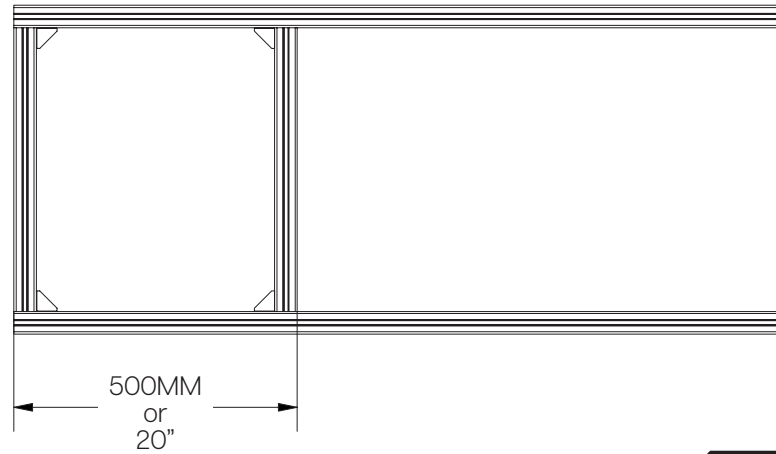
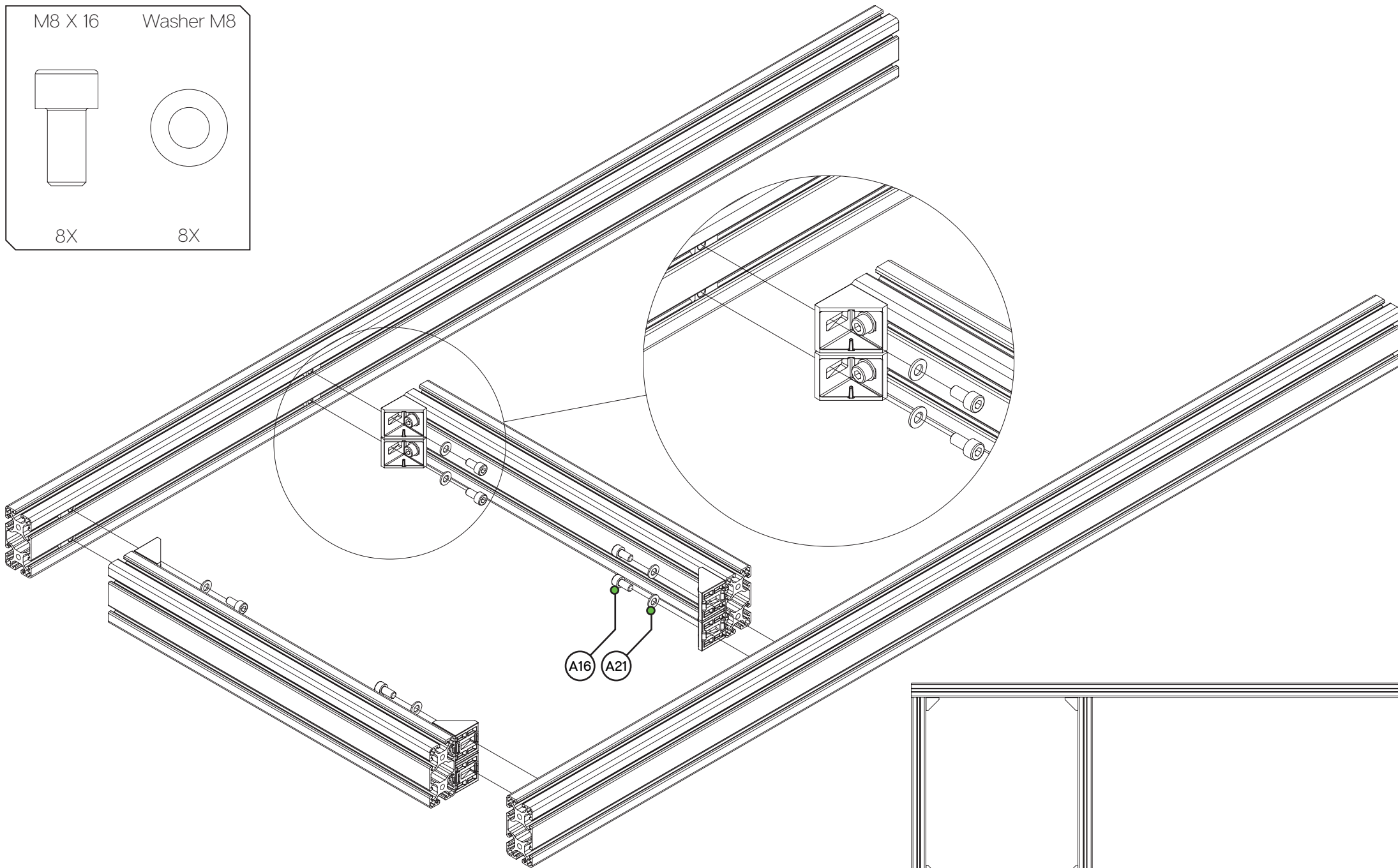

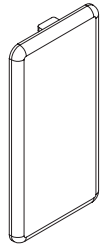
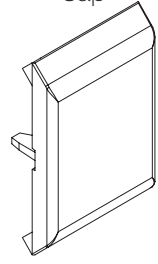
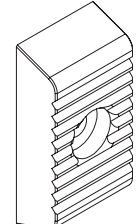
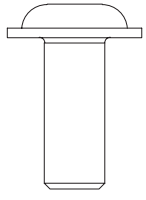
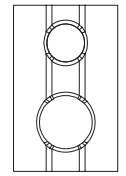

Profile 80x40 End-Cap	Corner Bracket Cap	Rubber Foot	M8 X 20	Slot-Nut M8
				
4X	8X	4X	4X	4X

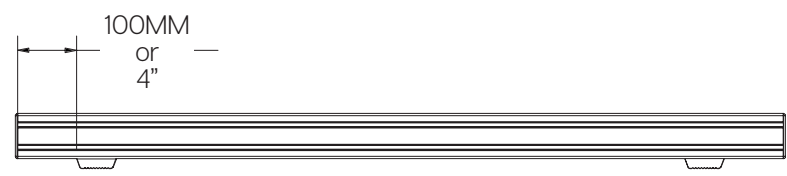
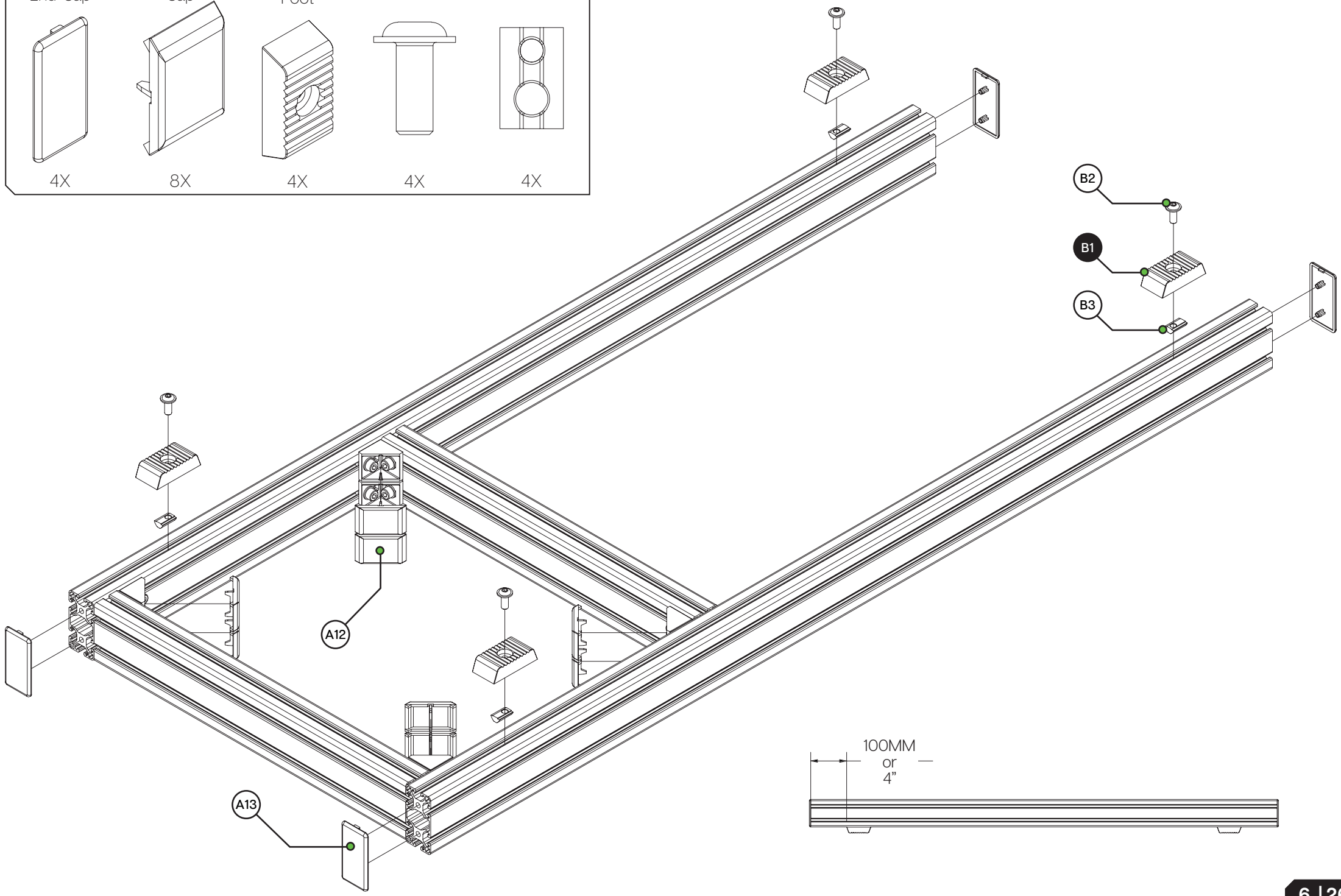

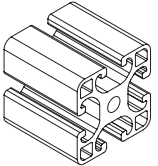
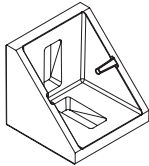
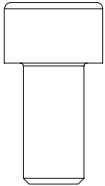
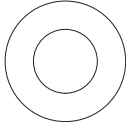
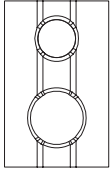

500MM	Corner Bracket*	M8 X 16	Washer M8	Slot-Nut M8
				
1X	2X	2X	2X	2X
<b>BUILD 2X</b>				

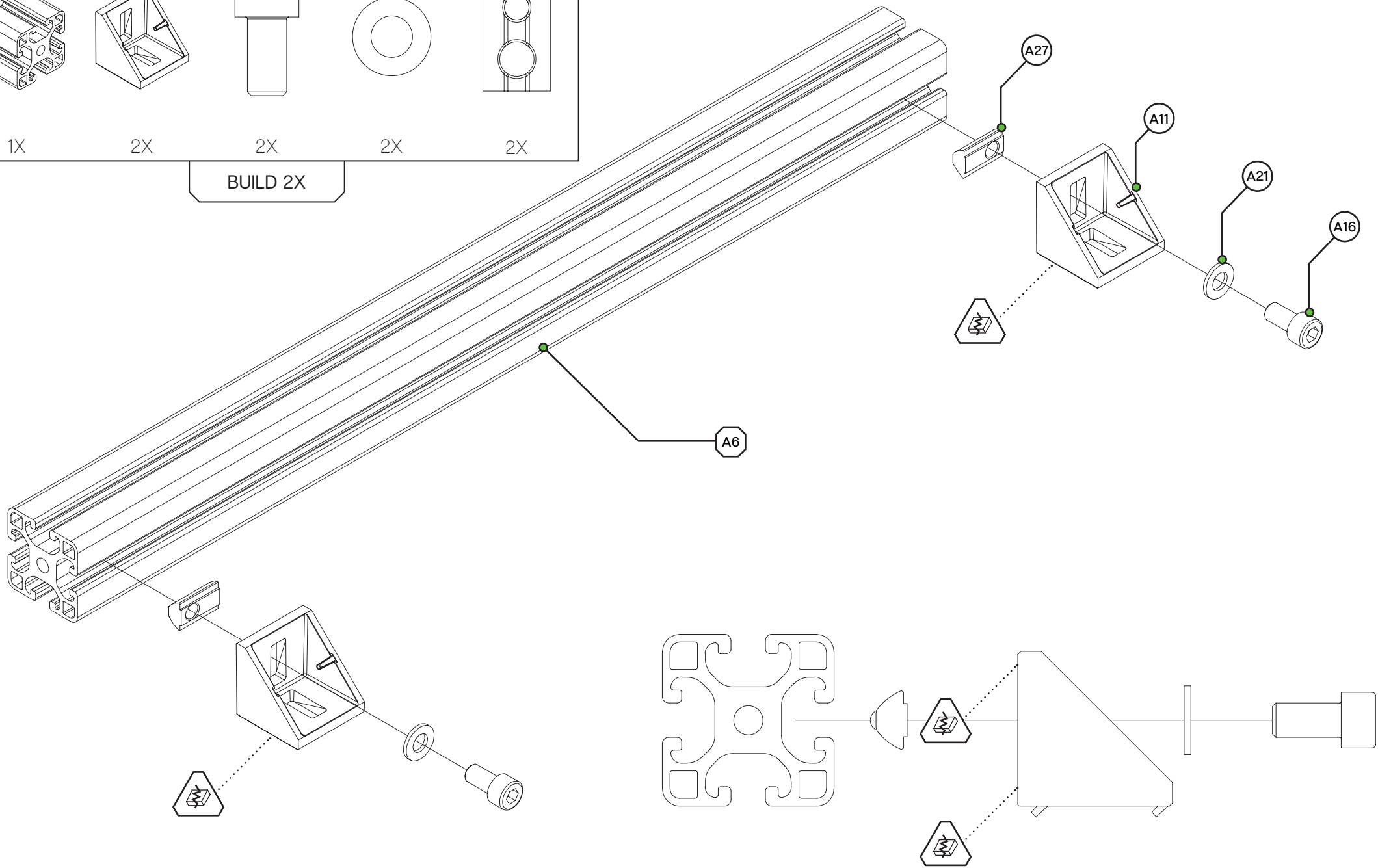

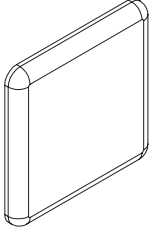
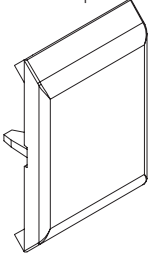
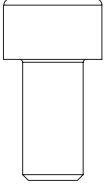
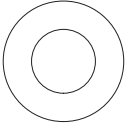
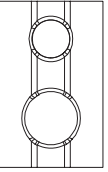
Profile 40X40 End-Cap	Corner Bracket Cap	M8 X 16	Washer M8	Slot-Nut M8
				
4X	4X	4X	4X	4X

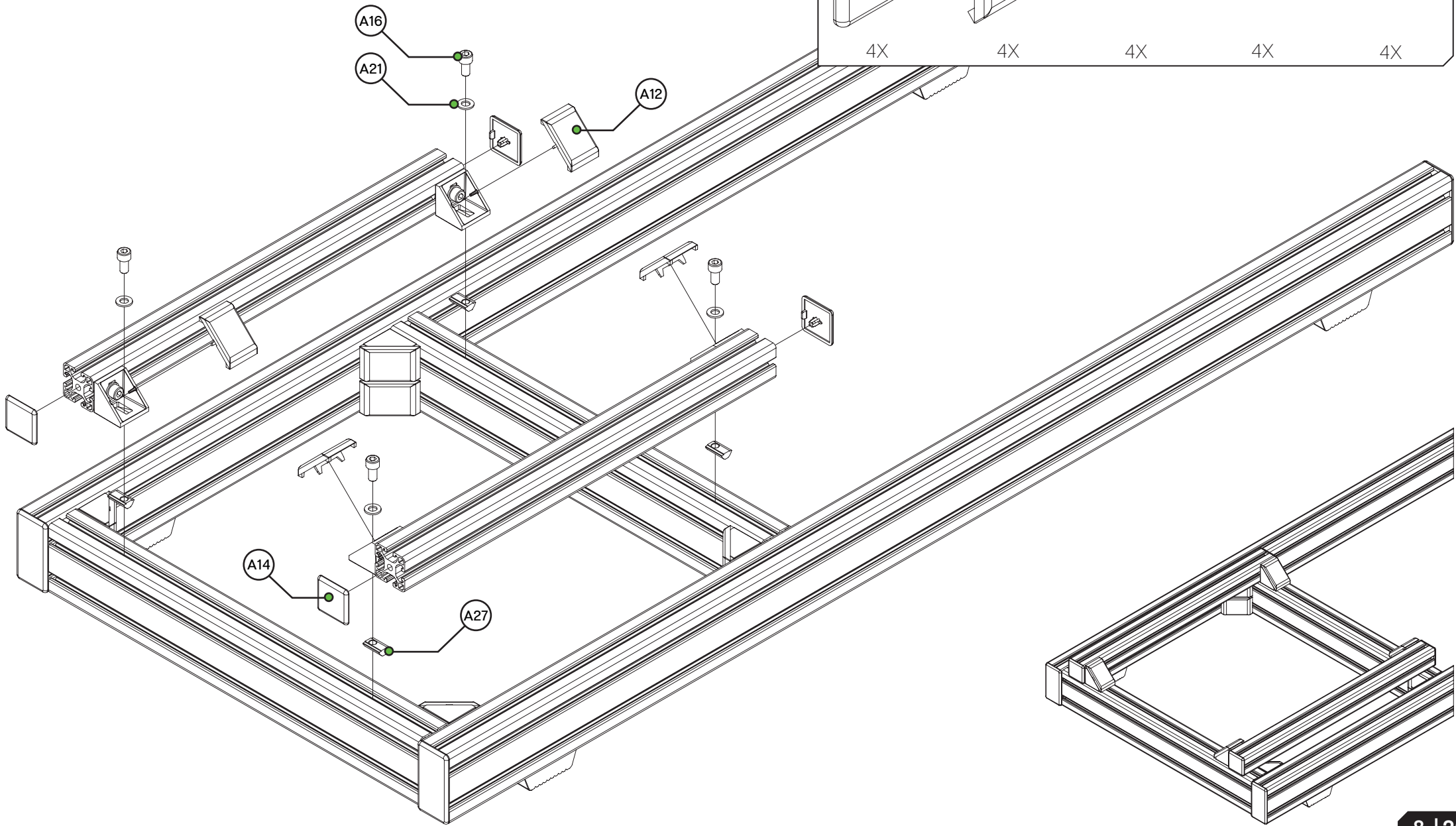

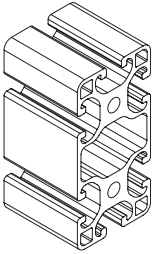
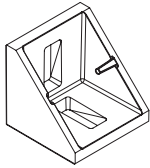
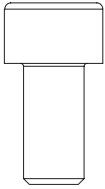
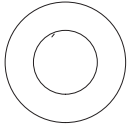
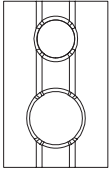
580MM	Corner Bracket	M8 X 16	Washer M8	Slot-Nut M8
				
1X	2X	2X	2X	2X
<b>BUILD 2X</b>				

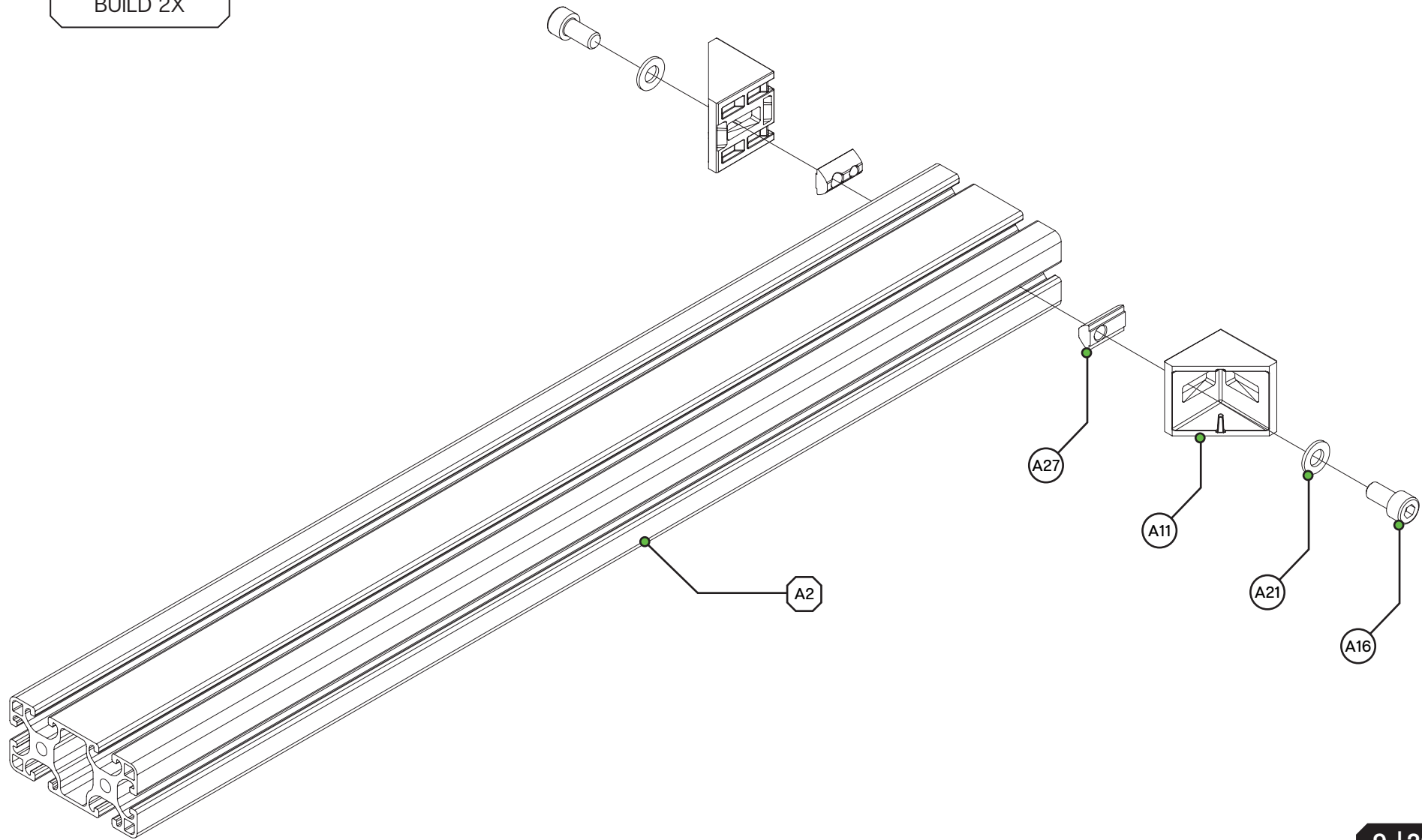

M8 X 16

Washer M8

Slot-Nut M8

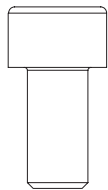

4X

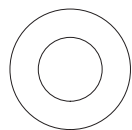

4X

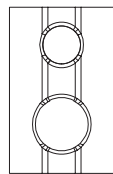

4X

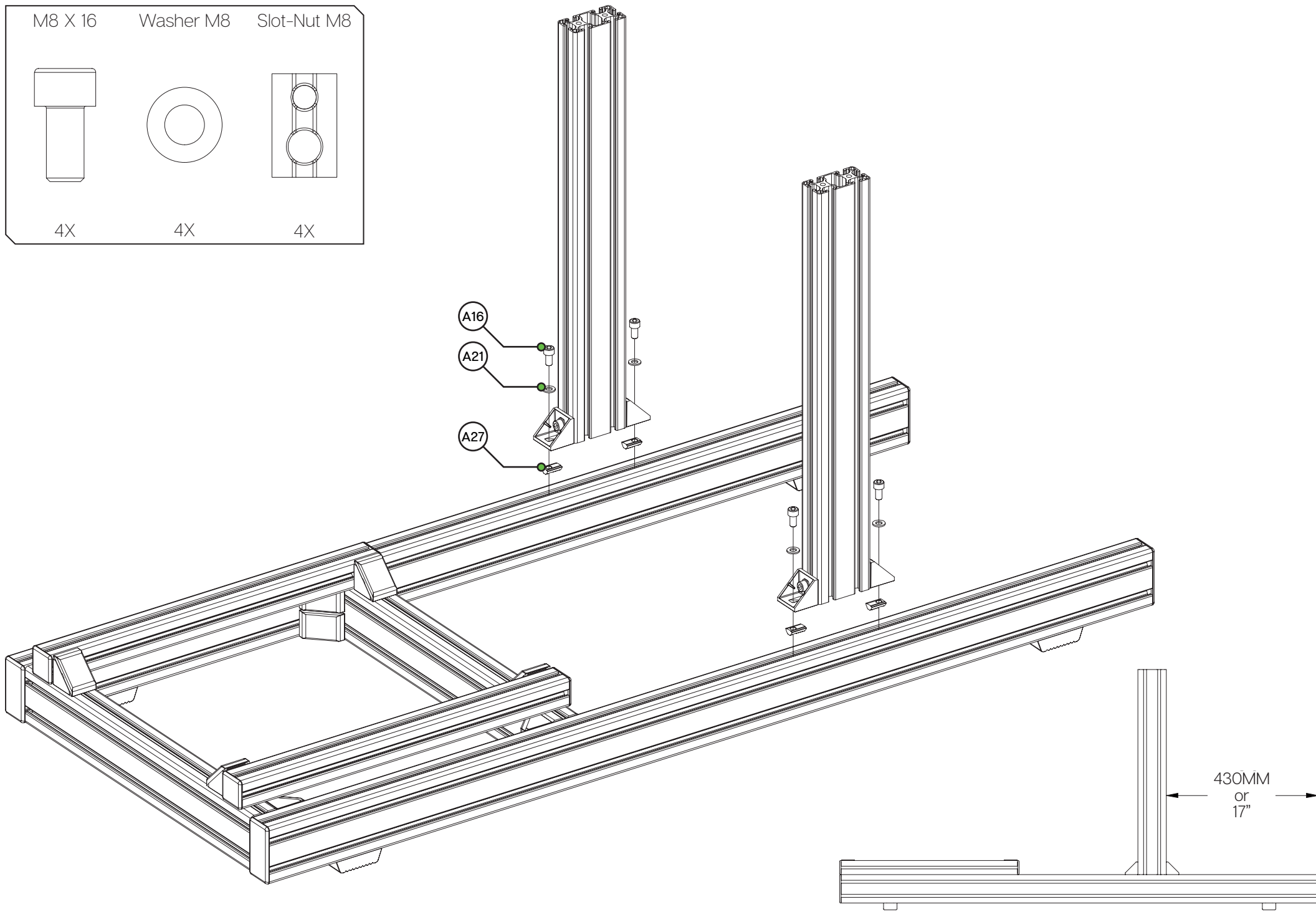

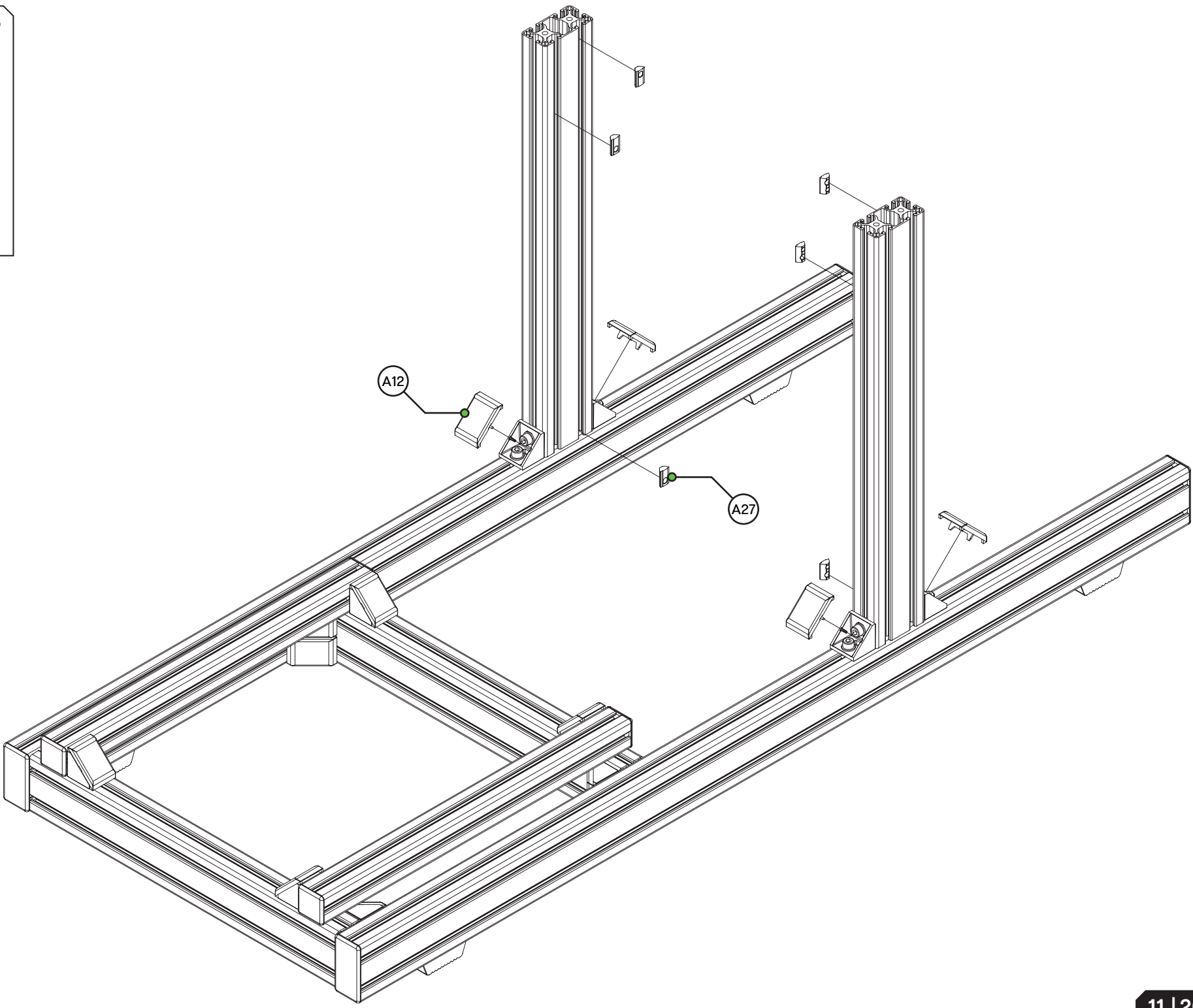
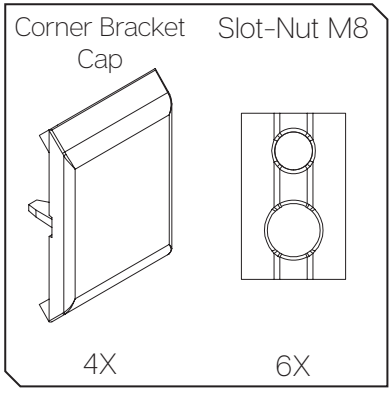

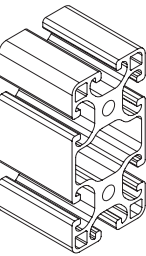
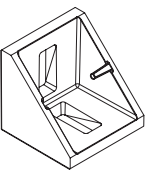
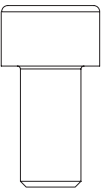
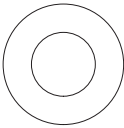
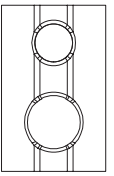
500MM	Corner Bracket	M8 X 16	Washer M8	Slot-Nut M8
				
1X	2X/2x*	4X	4X	4X

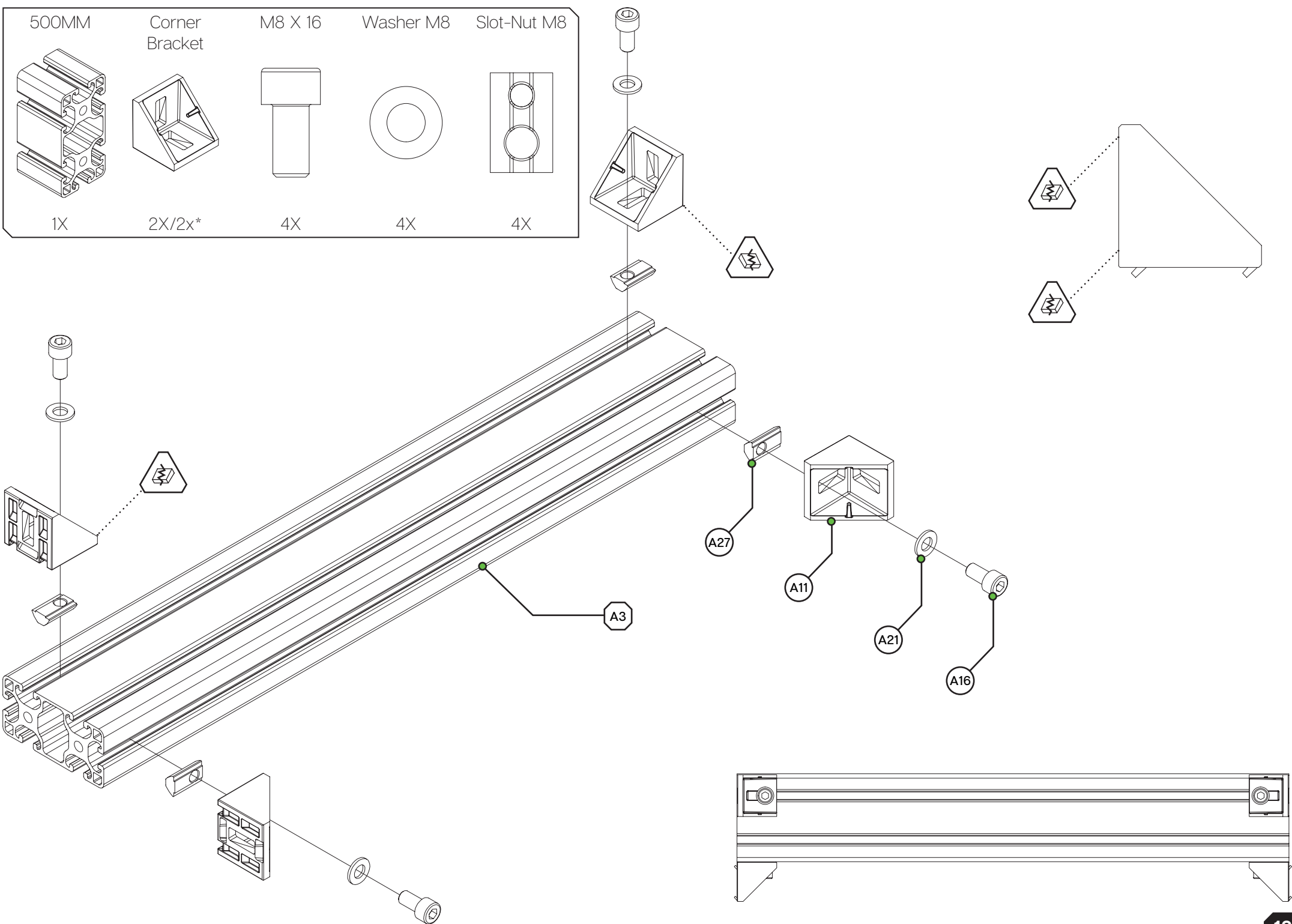



M8 X 16

Washer M8

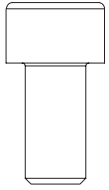

4X

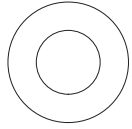

4X

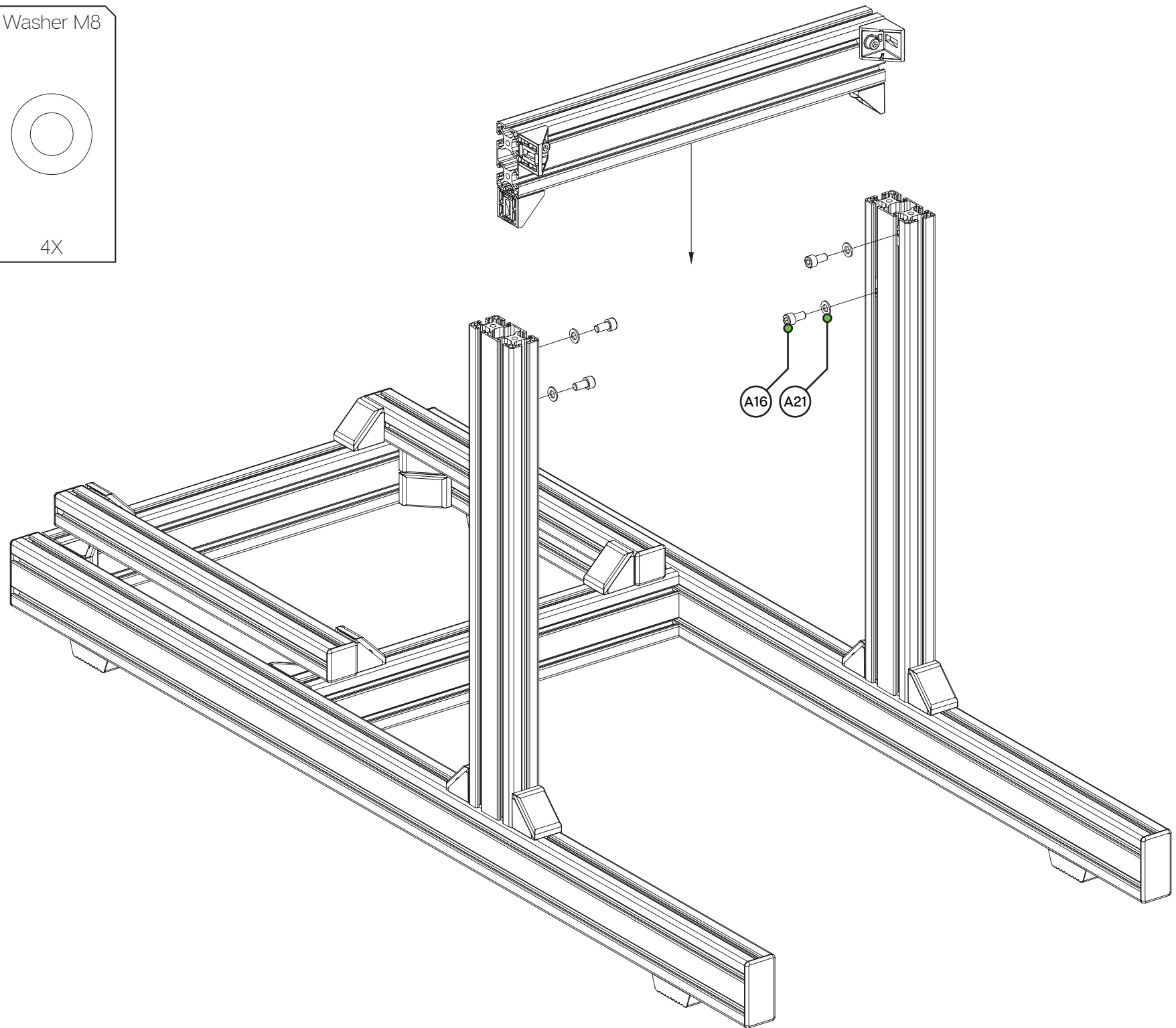



Profile 80x40  
End-Cap

Corner Bracket  
Cap

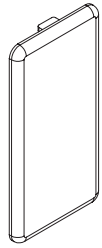

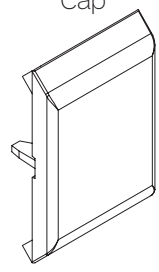

2X

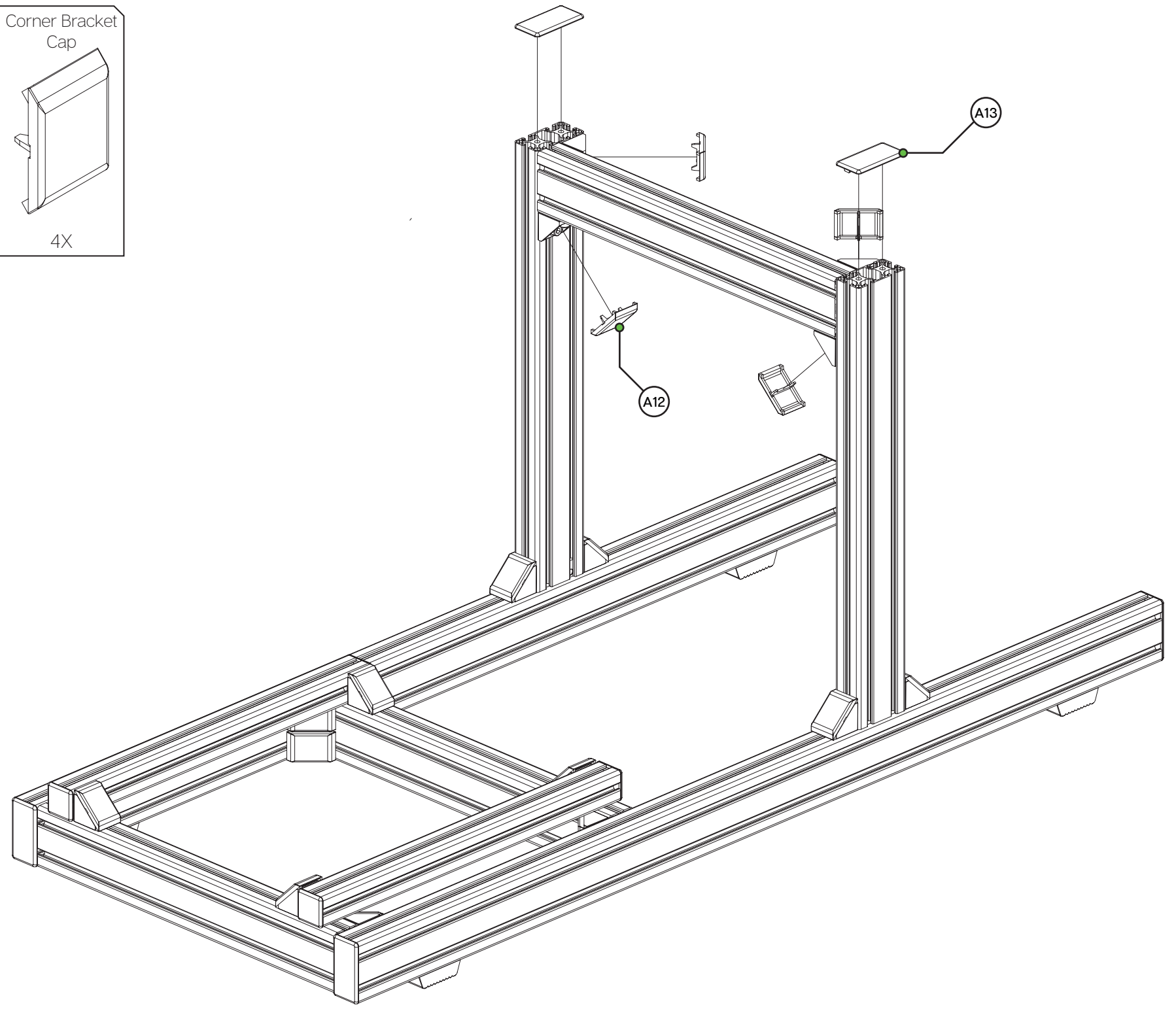

4X

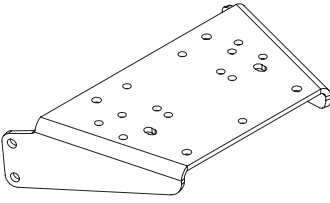
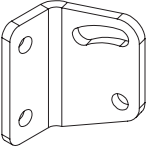

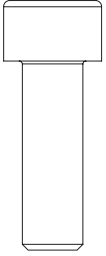
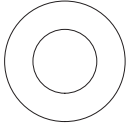
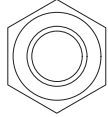
Wheel Deck	Wheel Deck Pivot Plate Left (A9)	Wheel Deck Pivot Plate Right (A10)	M8 X 25	Washer M8	Lock-Nut M8
					
1X	1X	1X	4X	8X	4X

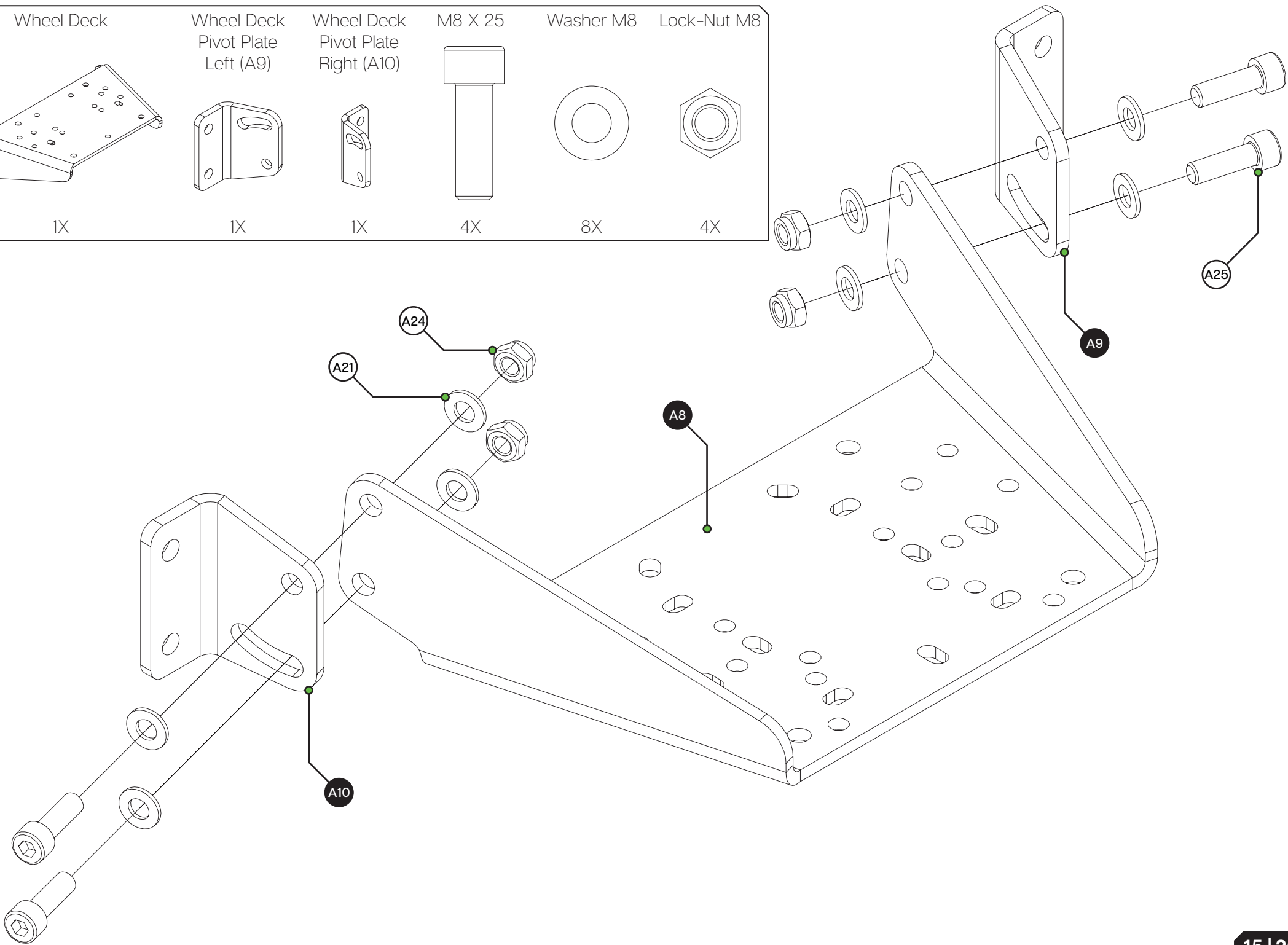

M8 X 16

Washer M8

Slot-Nut M8

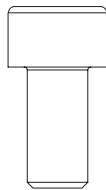

4X

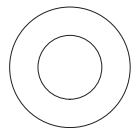

4X

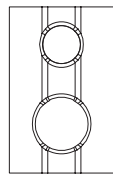

4X

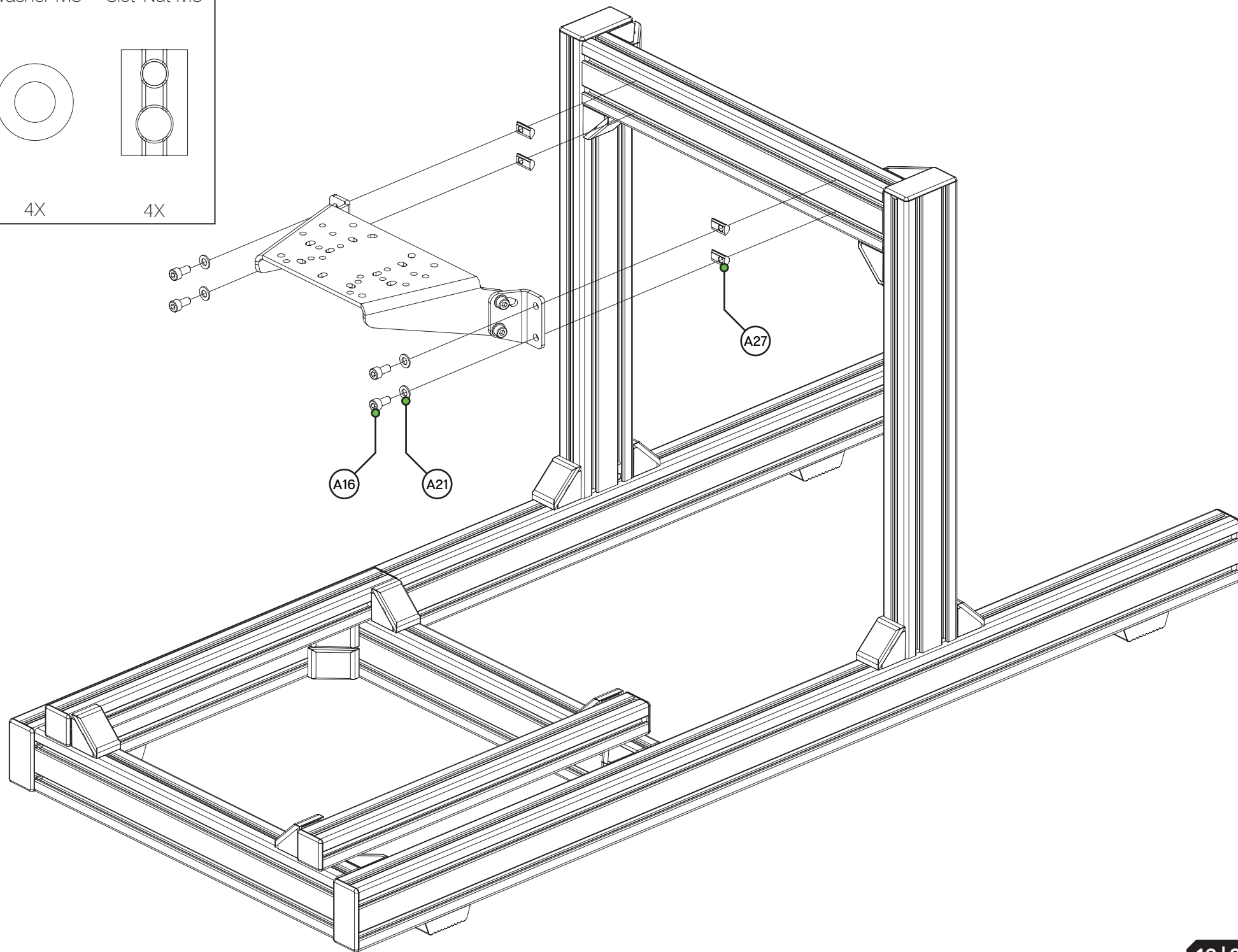

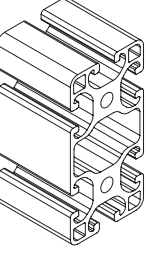
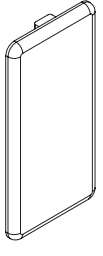
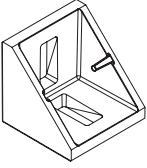
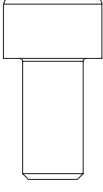
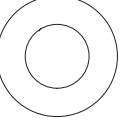
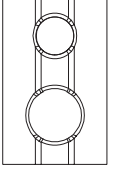
200MM	Profile 80X40 End-Cap	Corner Bracket	M8 X 16	Washer M8	Slot-Nut M8
					
1X	1X	1X	1X	1X	1X
<b>BUILD 2X</b>					

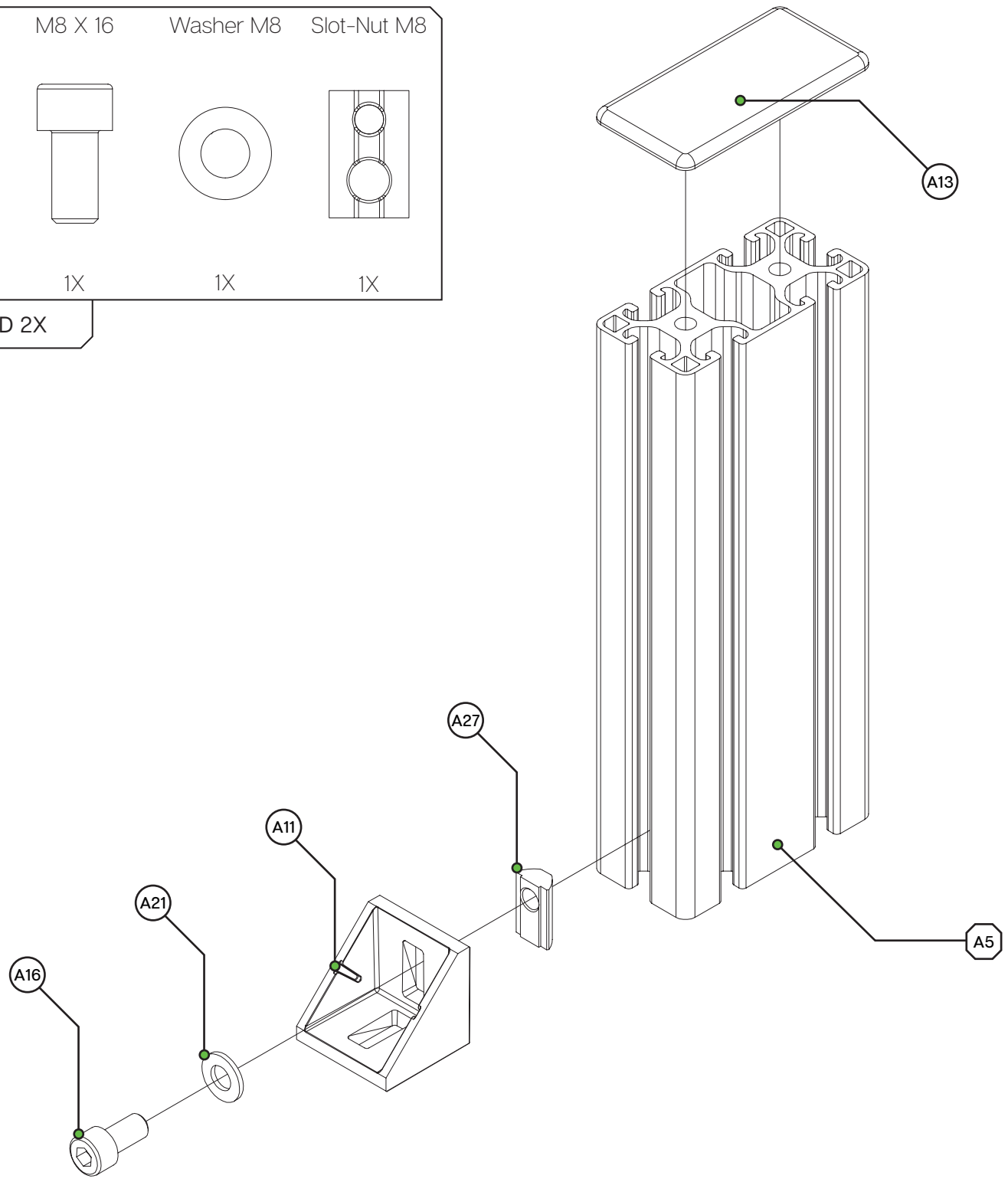

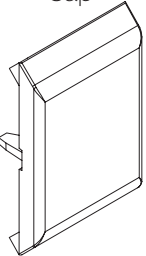
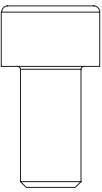
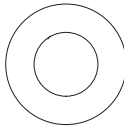
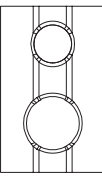
Corner Bracket Cap	M8 X 16	Washer M8	Slot-Nut M8
			
2X	2X	2X	4X

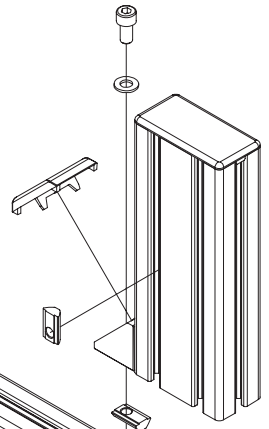
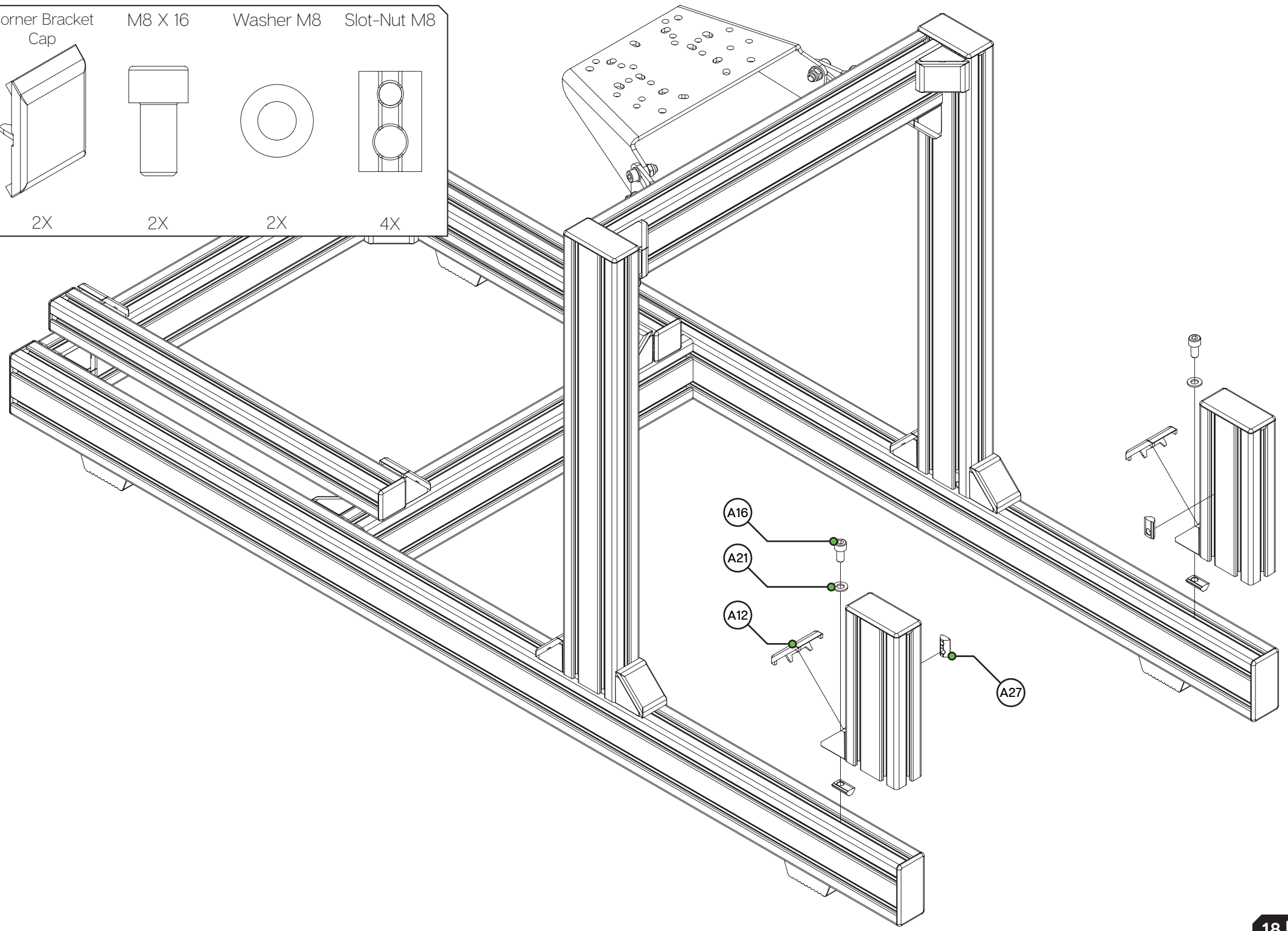

Pedal Deck

M8 X 16

Washer M8

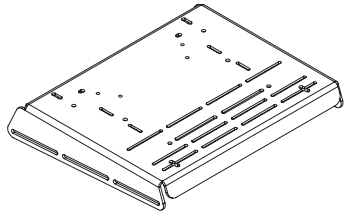

1X

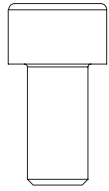

4X

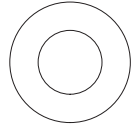

4X

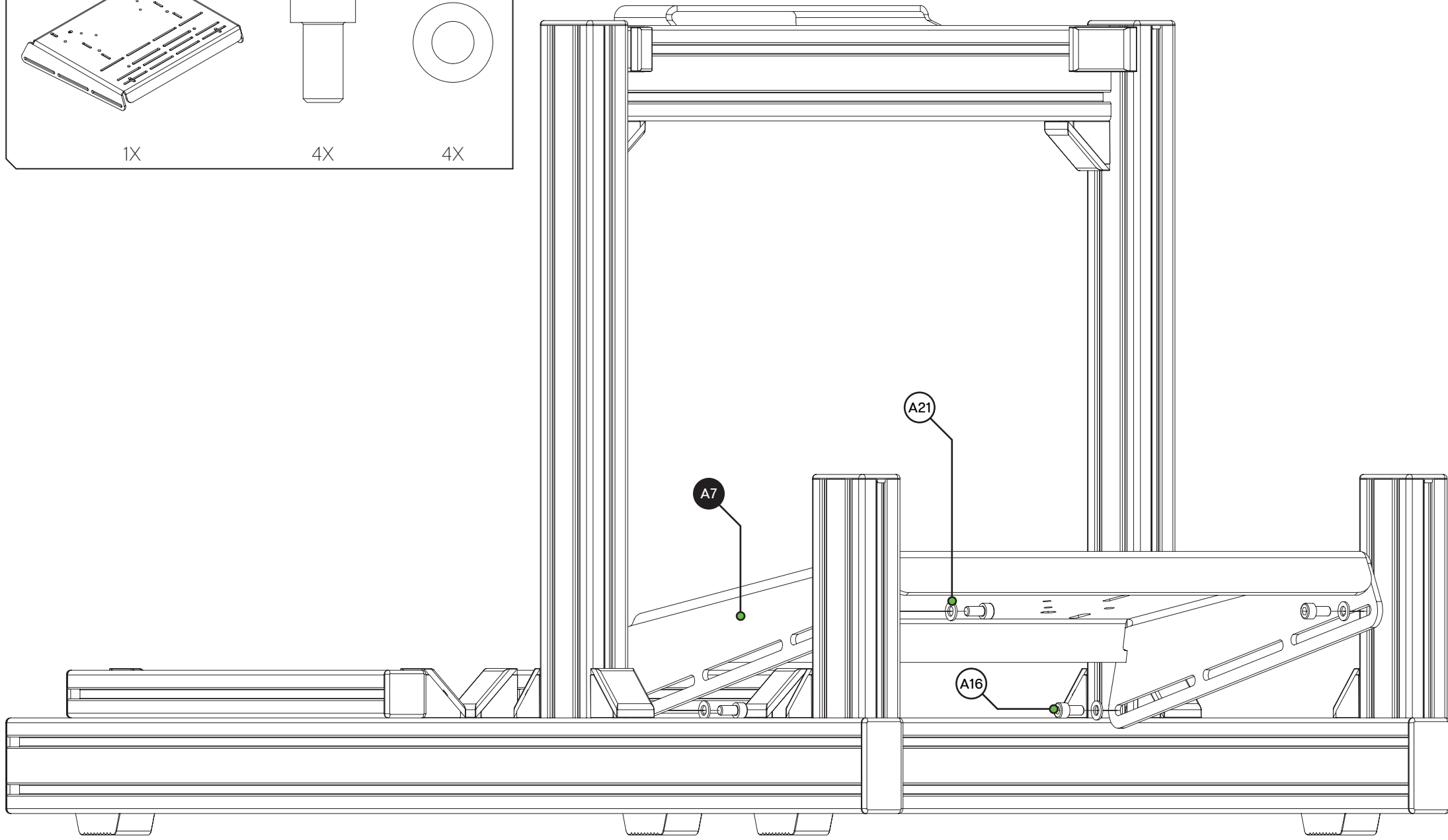

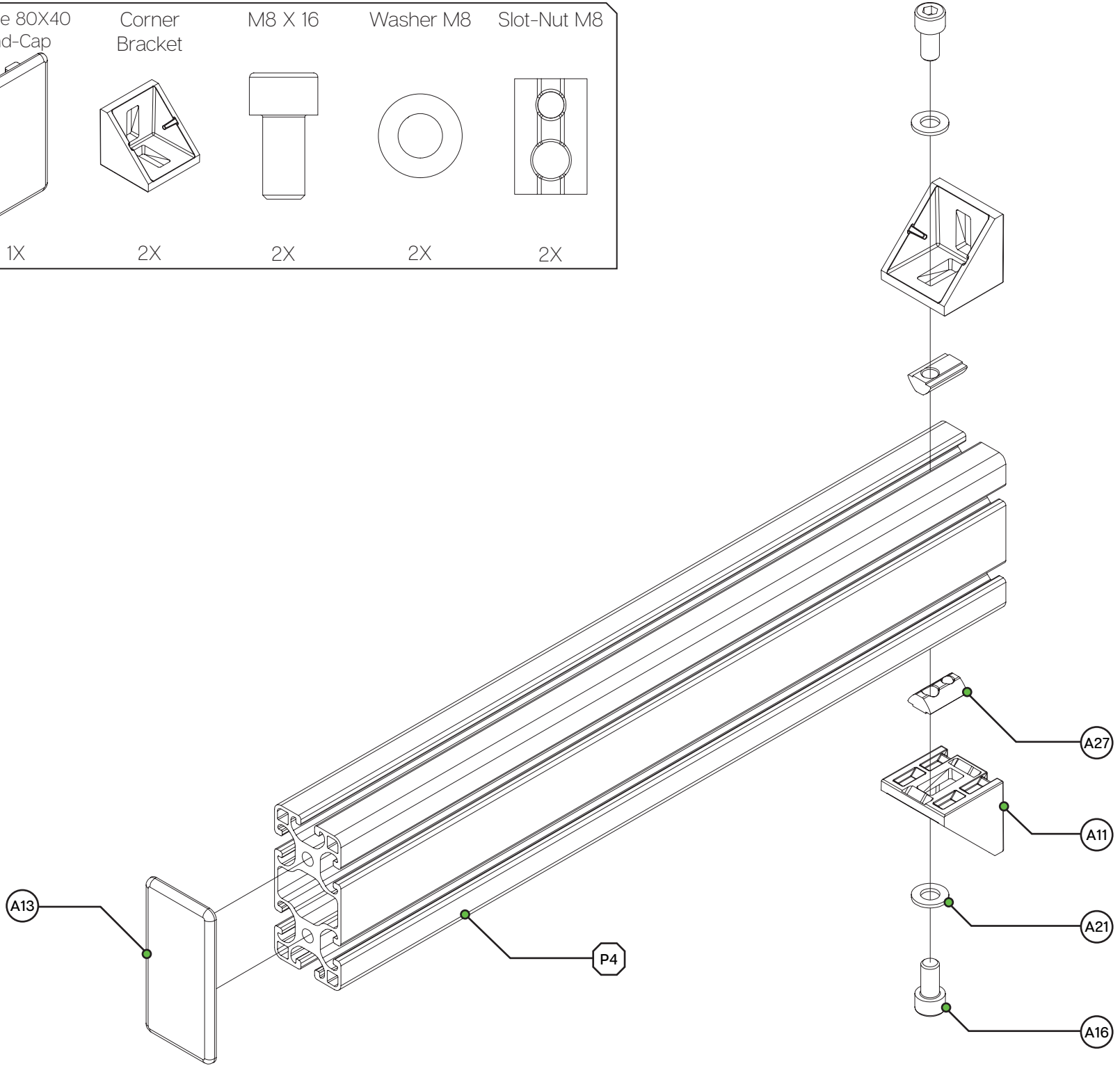
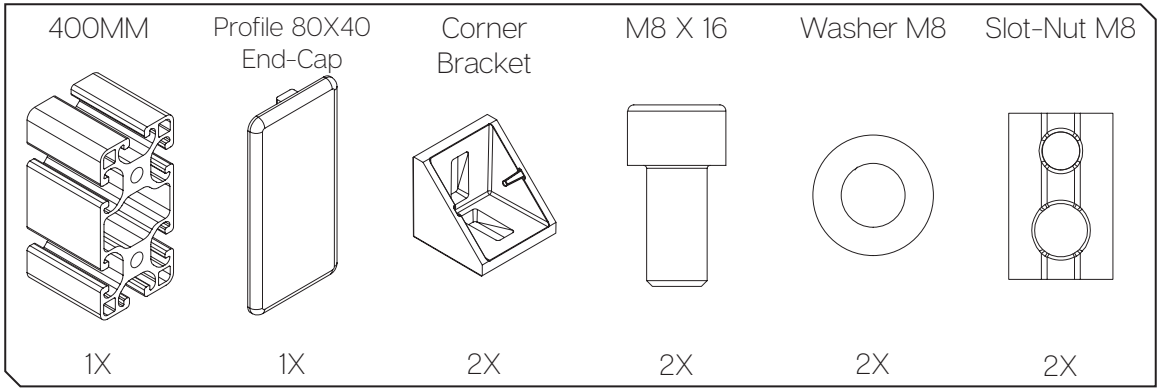



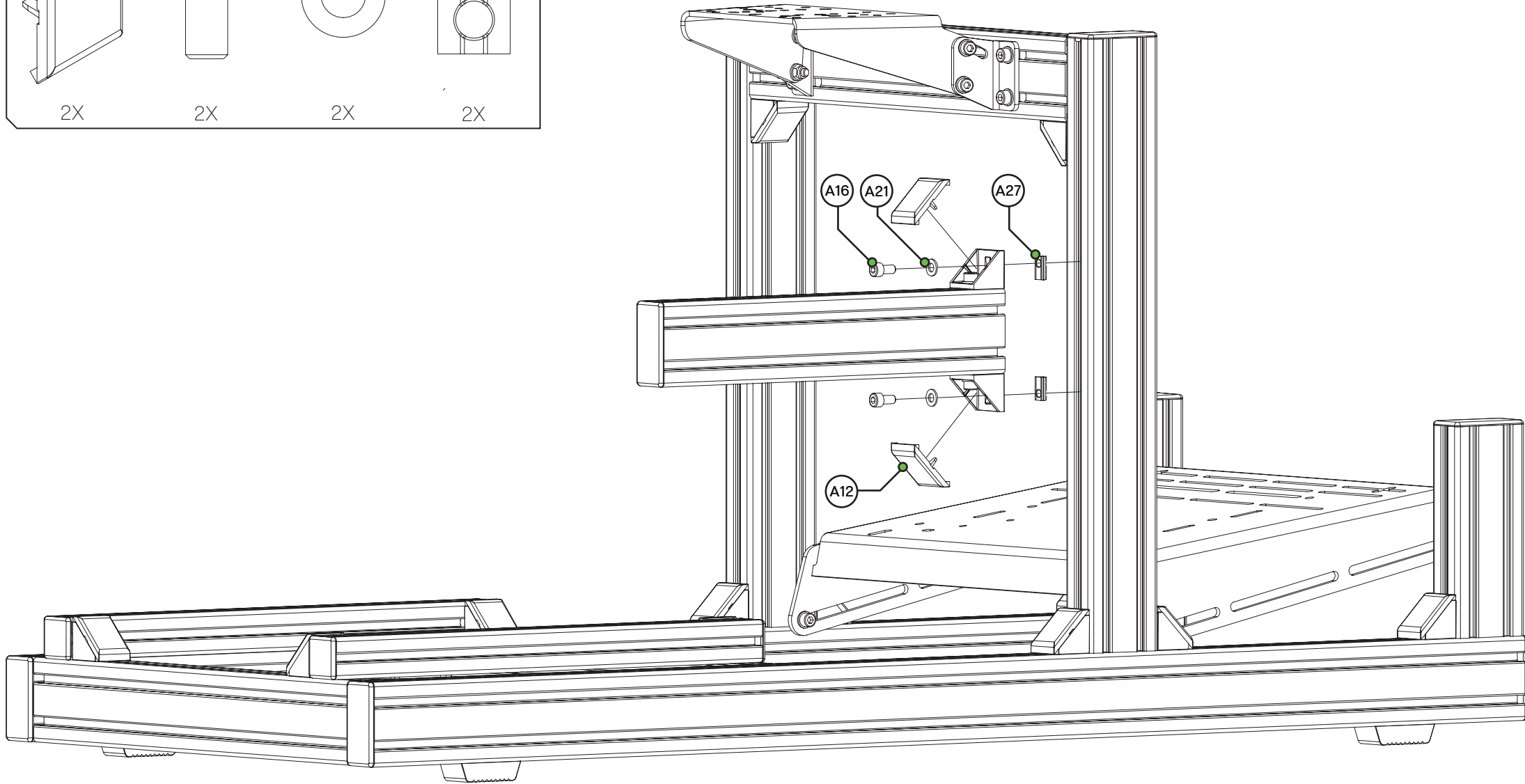
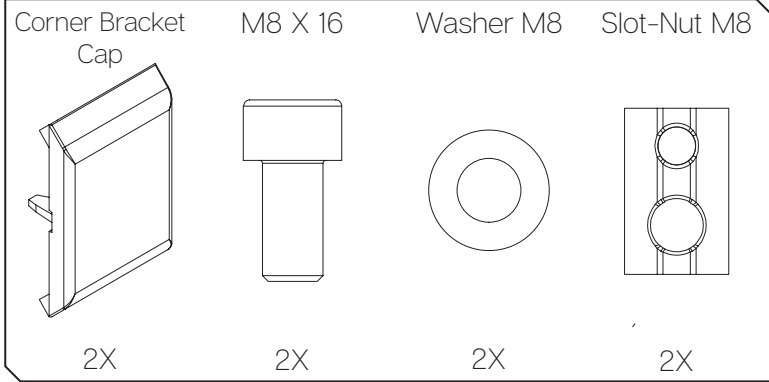

## GT1-EVO COCKPIT PROFILE KIT

#	Part	QTY	Note
A1	80X40 Length=1350mm	2	
A2	80X40 Length=580mm	2	
A3	80X40 Length=500mm	3	
A4	80X40 Length=400mm	1	
A5	80X40 Length=200mm	2	
A6	40X40 Length=500mm	2	

## HARDWARE KIT

A7	Pedal deck	1	
A8	Wheel deck	1	
A9	Wheel deck pivot plate LEFT	1	
A10	Wheel deck pivot plate RIGHT	1	
A11	Corner bracket 40x40	24	
A12	Corner bracket 40x40 cap	24	
A13	Profile 80x40 end-cap	9	
A14	Profile 40x40 end-cap	4	
A15	Bolt M8 X 25 DIN 912	4	
A16	Bolt M8 X 16 DIN 912	56	
A17	Bolt M8 X 12 DIN 912	12	extra
A18	Bolt M6 X 20 DIN 912	12	extra
A19	Bolt M6 X 16 DIN 912	12	extra
A20	Bolt M5 X 25 DIN 912	12	extra

#	Part	QTY	Note
A21	Washer M8 DIN 125-A	64	
A22	Washer M6 DIN 125-A	24	extra
A23	Washer M5 DIN 125-A	24	extra
A24	Lock-Nut M8 DIN 985	4	
A25	Lock-Nut M6 DIN 985	12	extra
A26	Lock-Nut M5 DIN 985	12	extra
A27	Slot-Nut M8	56	

## Sim-Lab Rubber feet set HARDWARE KIT

#	Part	QTY	Note
B1	Rubber foot	4	
B2	Bolt M8 X 20 DIN 7380-2	4	
B3	Slot-Nut M8	4	

*Disclaimer: for some entries on this page, we supply more than required as spare materials. Don't worry if you have some leftovers, this is intentional.*

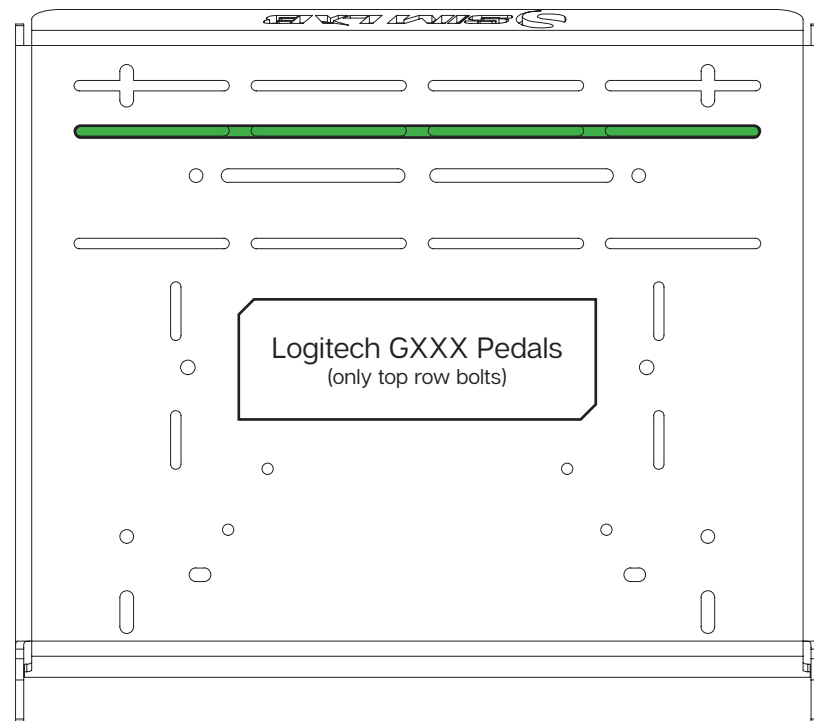
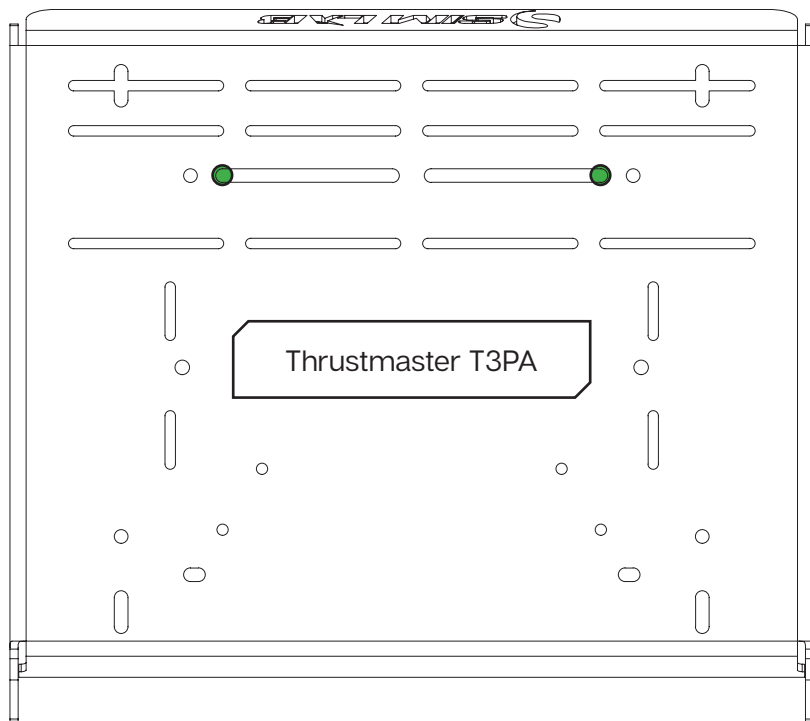
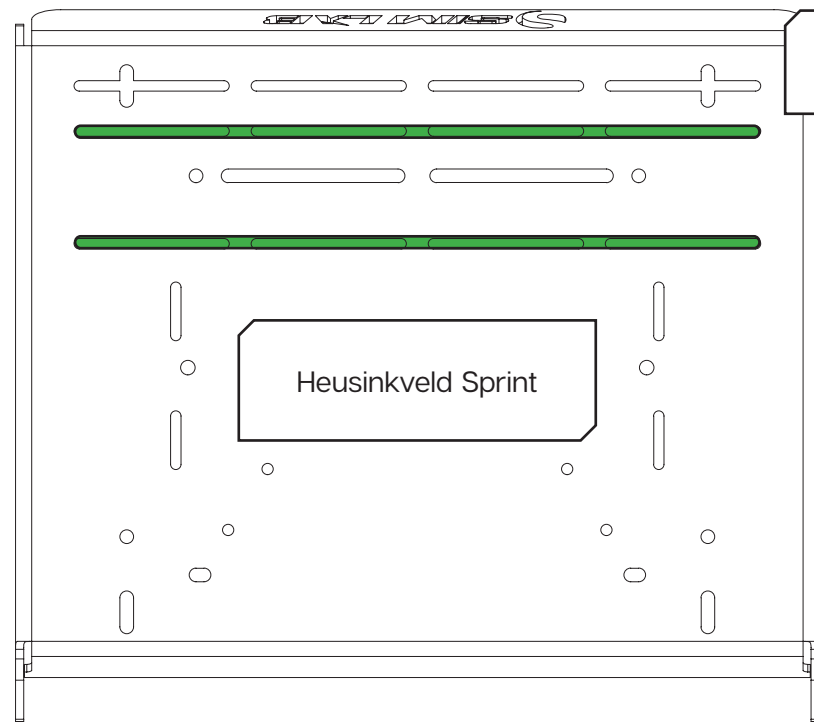
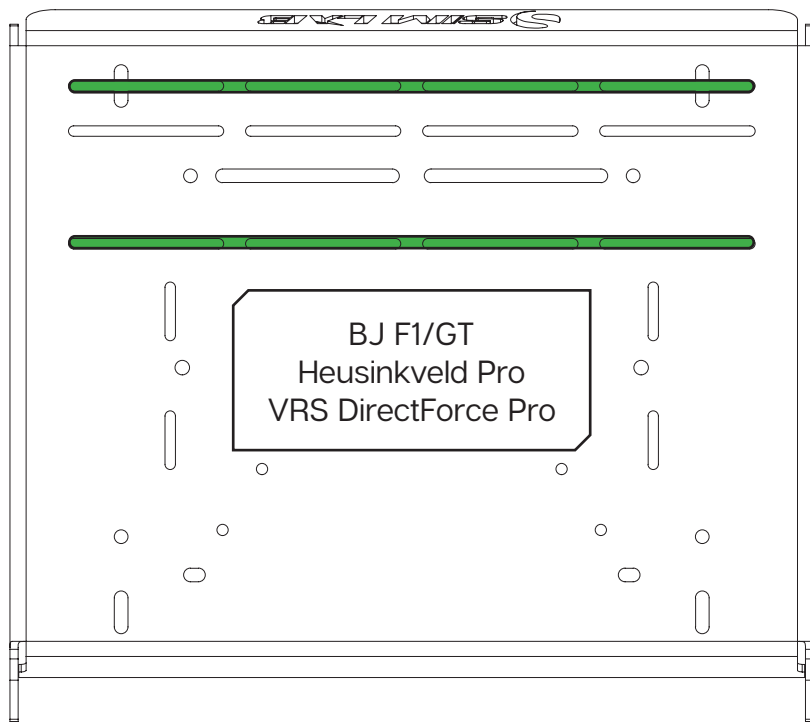

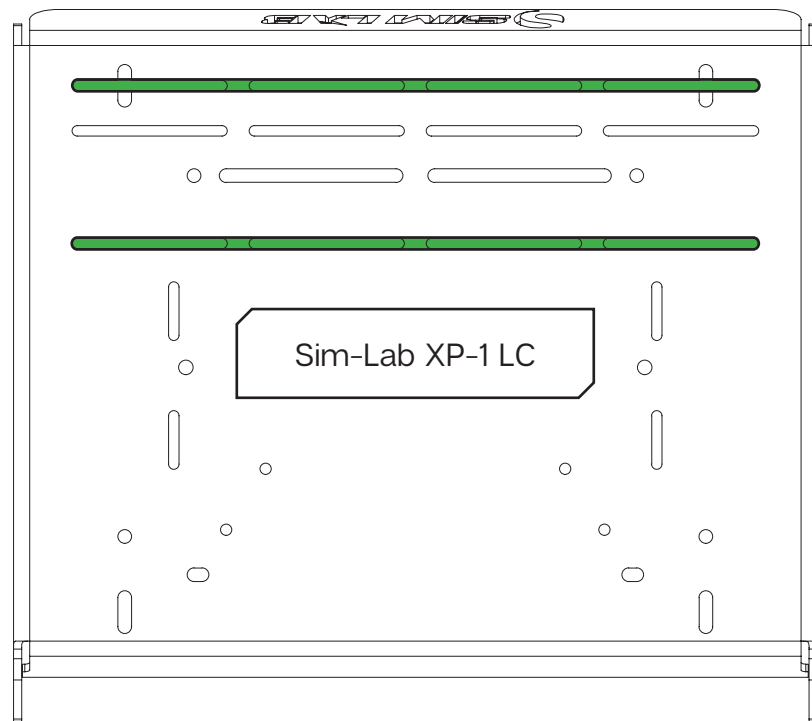
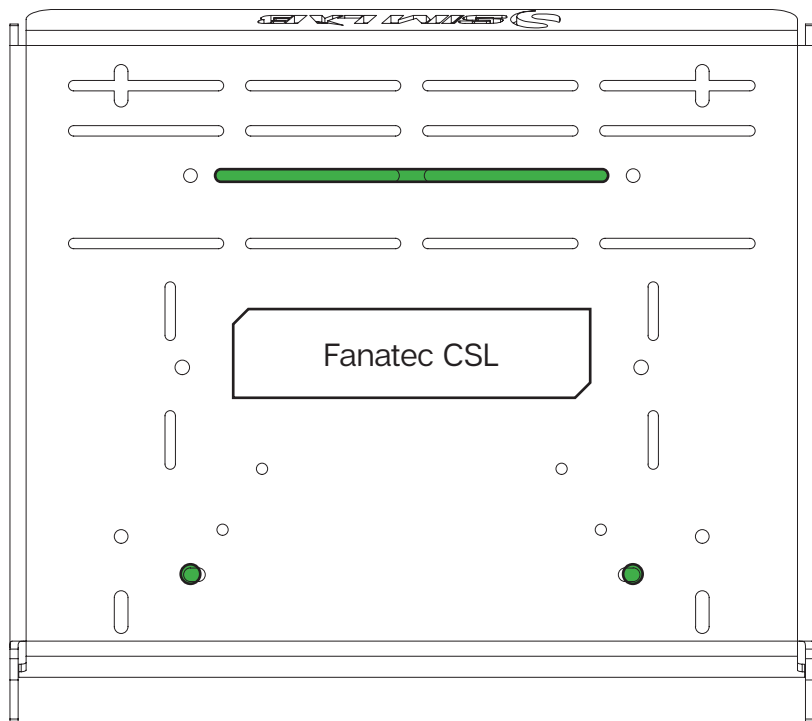
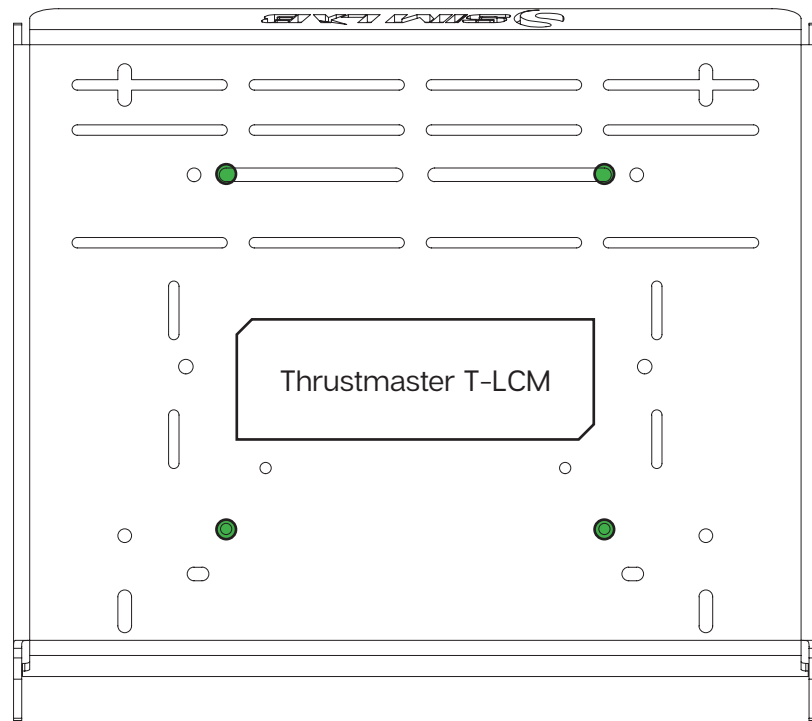
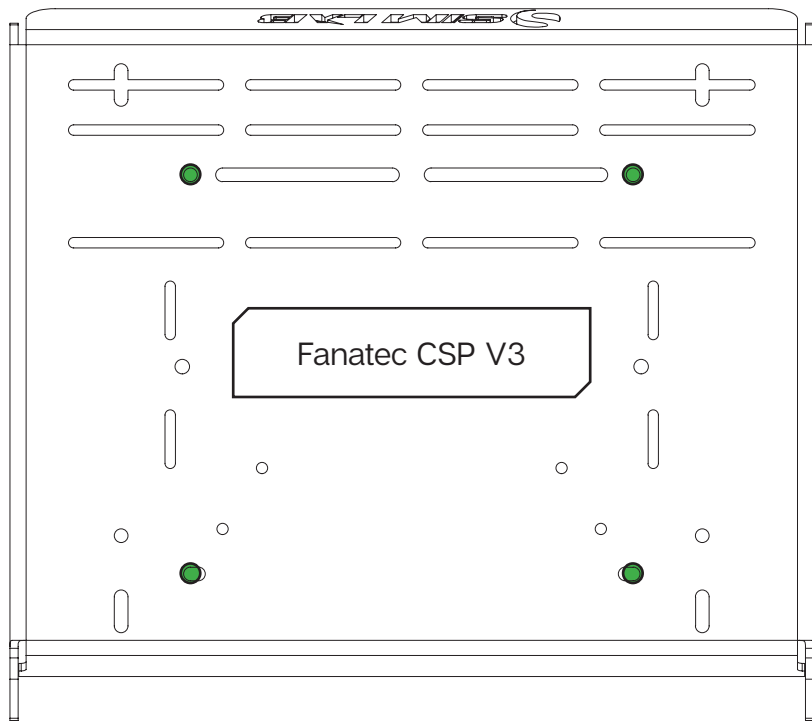

Accuforce 1/2

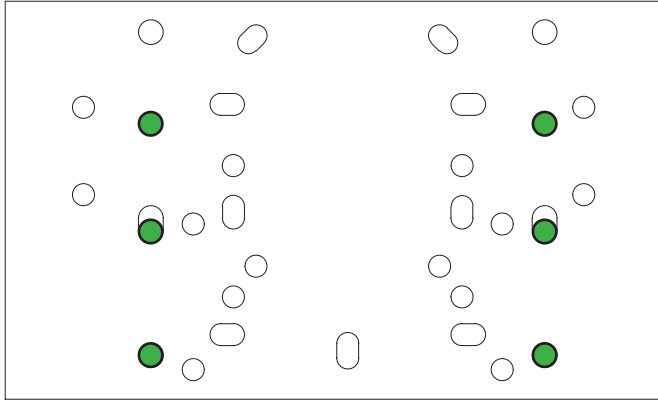

Asetek Forte/ Invicta Prima

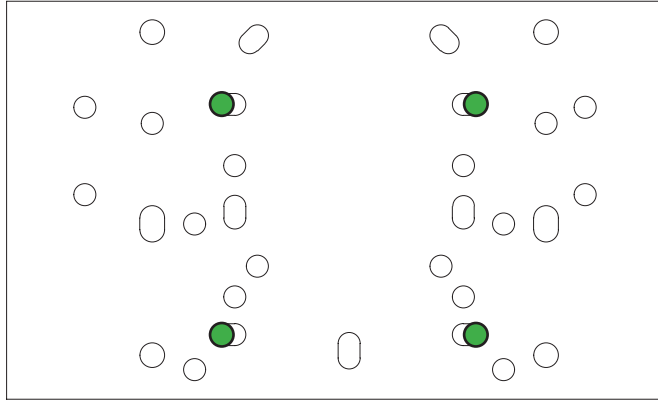

Fanatec

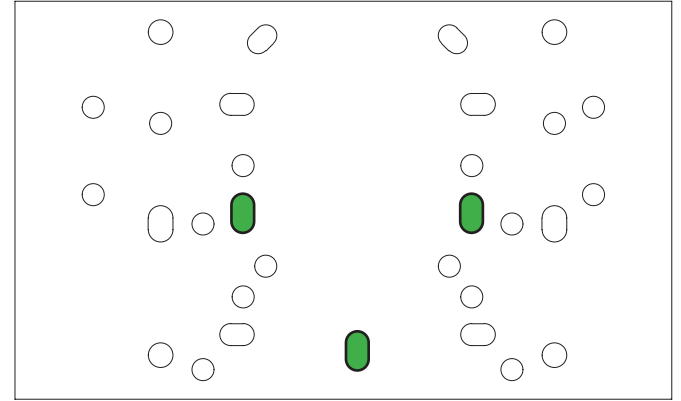

Logitech

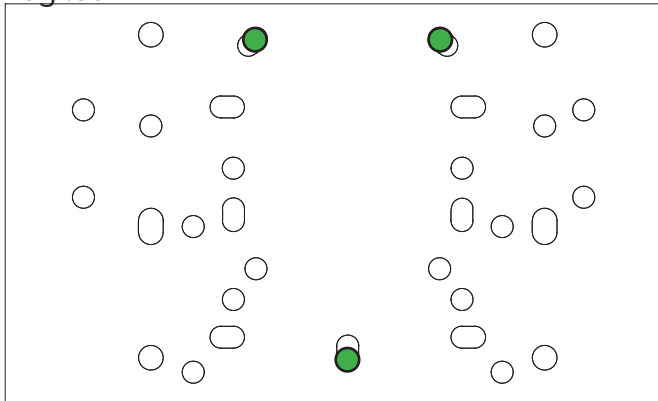

MOZA

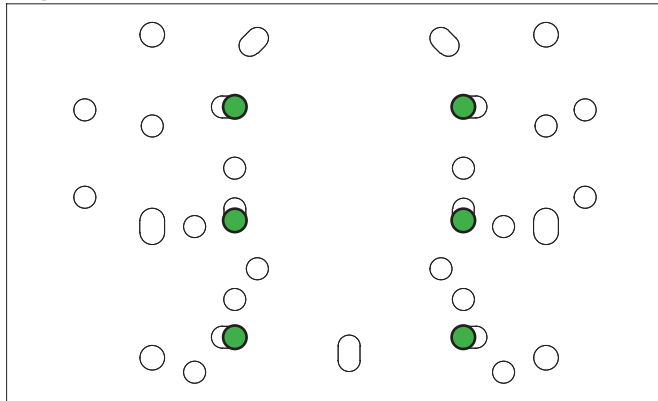

SIMAGIC

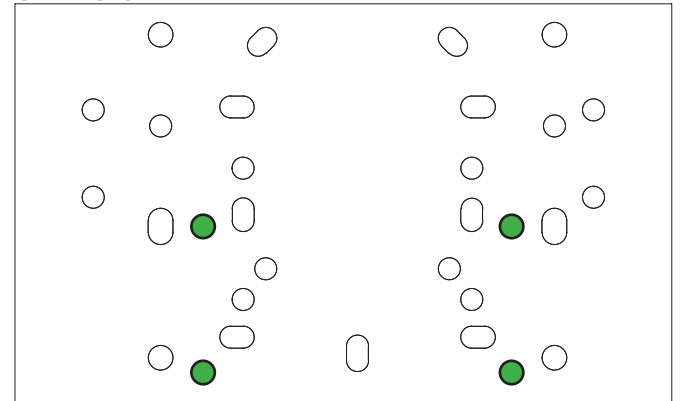

Thrustmaster

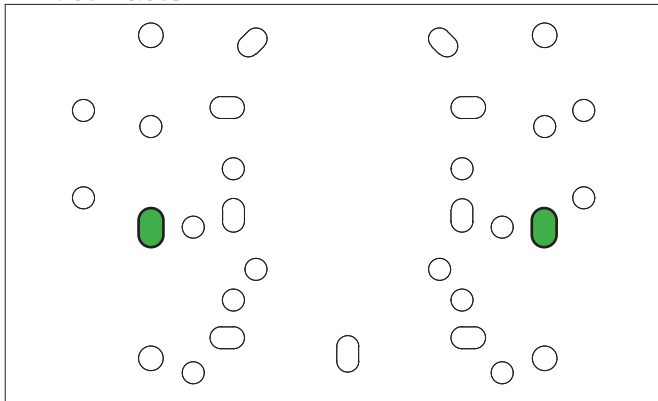

Thrustmaster T818

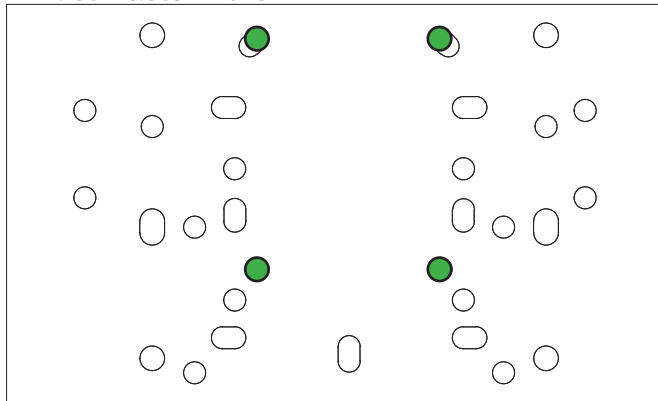

If you still have some questions regarding assembly of this product or about the manual itself, please refer to our support department. They can be reached at

support@sim-lab.eu

Alternatively, we now have a Discord server where there are quite some experienced Sim-Lab customers hanging out. They might just help you along if you ask them nicely ;)

[www.sim-lab.eu/discord](http://www.sim-lab.eu/discord)

If you feel like printing this manual, please consider the environment before doing so. For the best results, make sure you print at 100% scale without borders.

[Product page on the Sim-Lab website:](#)



[Instruction video on YouTube:](#)



# **SIM LAB**

## INSTRUCTION MANUAL

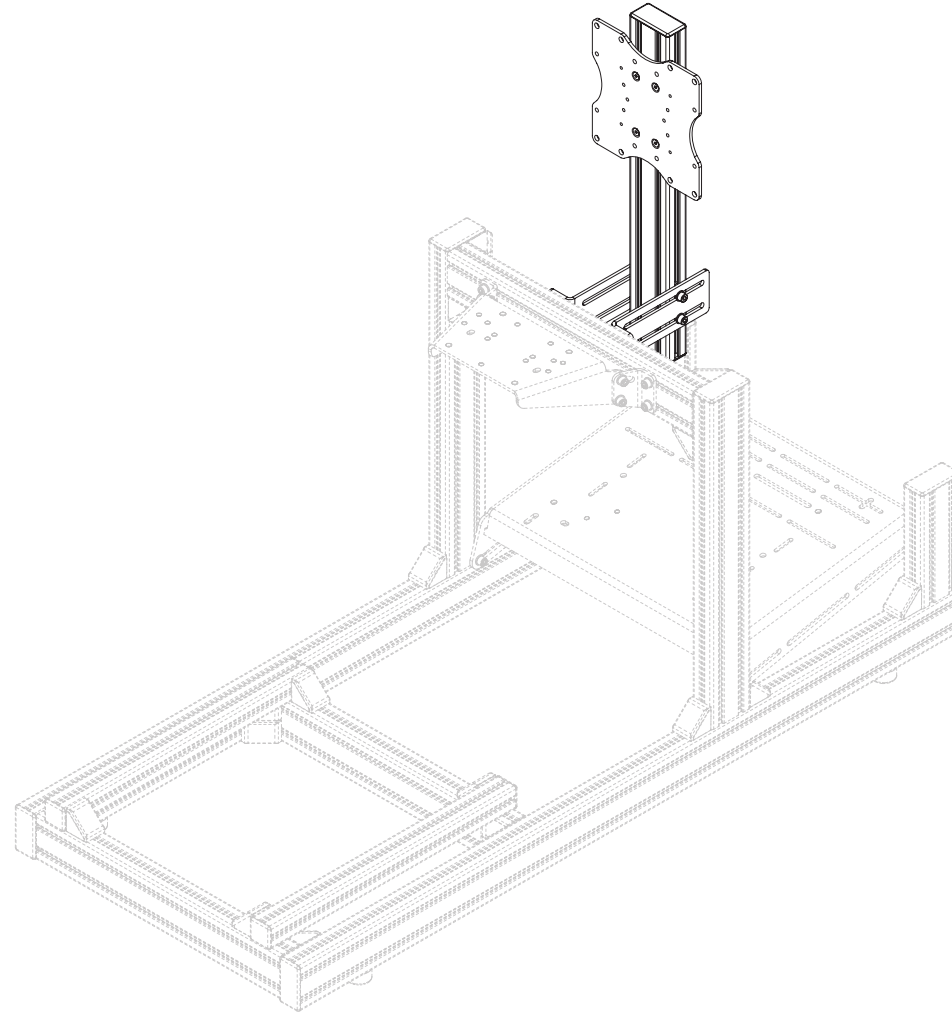

### **GT1-EVO SINGLE SCREEN HOLDER**

**VERSION 1.2**

Last updated: 05-12-2023



## BEFORE YOU START:

Thank you for purchasing this Sim-Lab product! On the following pages, you will find detailed instructions on assembly. This requires only a set of simple tools and some of your time. Please check the bill of materials before starting (page 8) and make sure all the parts are delivered.

### Inserting Slot-Nuts:

You got excited, finished the build, put the caps on, but forgot to install one element. Do not worry. It happens to everyone. In this diagram, you can see how to insert a Slot-Nut directly into the slot from the side. You can also use one of your smaller Hex wrenches to help wiggle the Slot-Nut in place.

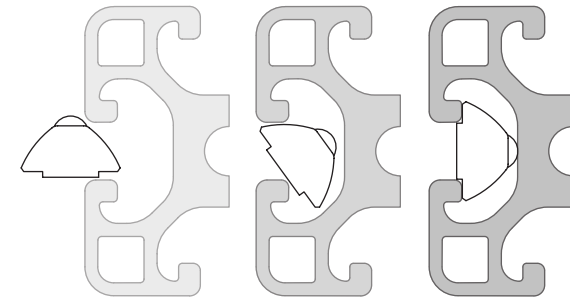

### Tools needed:

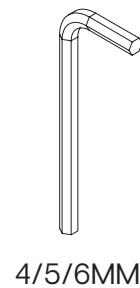

4/5/6MM

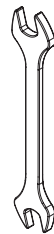

7MM



+

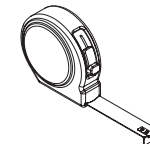
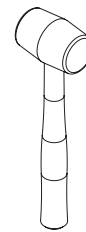

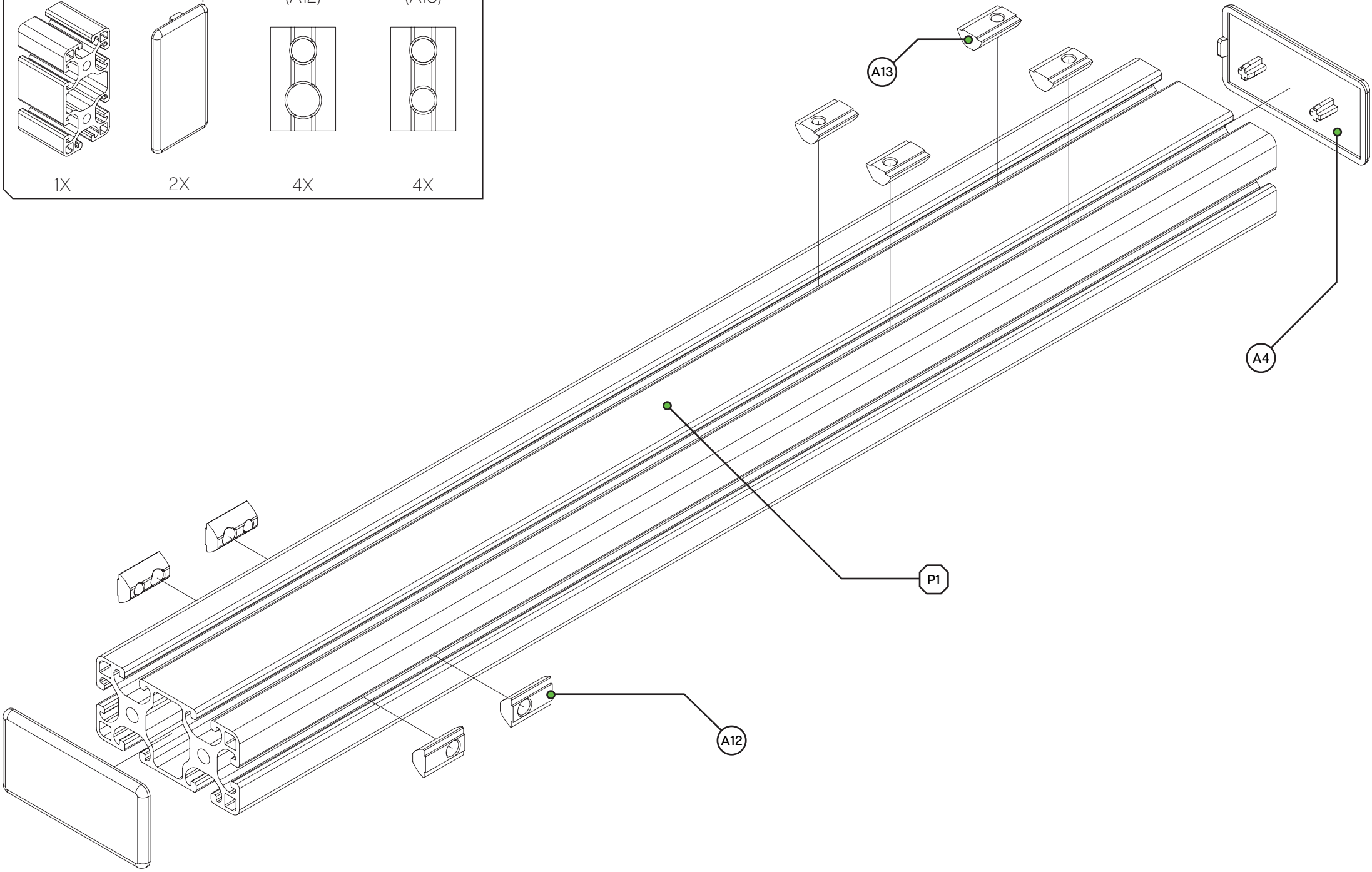
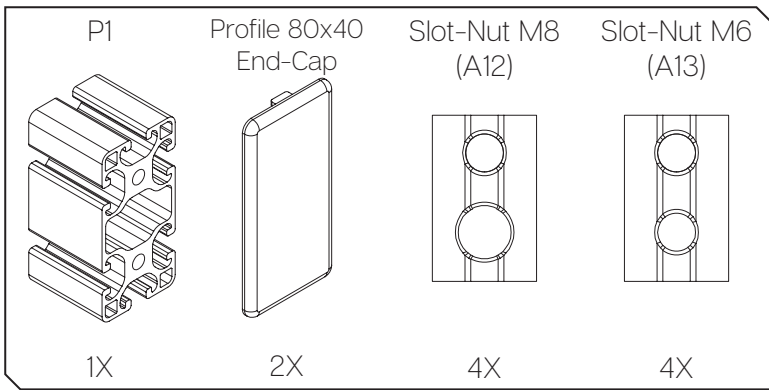

VESA 200

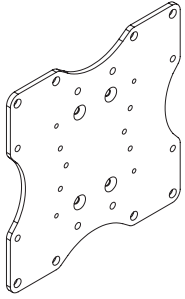

1X

M6 X 16

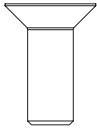

4X

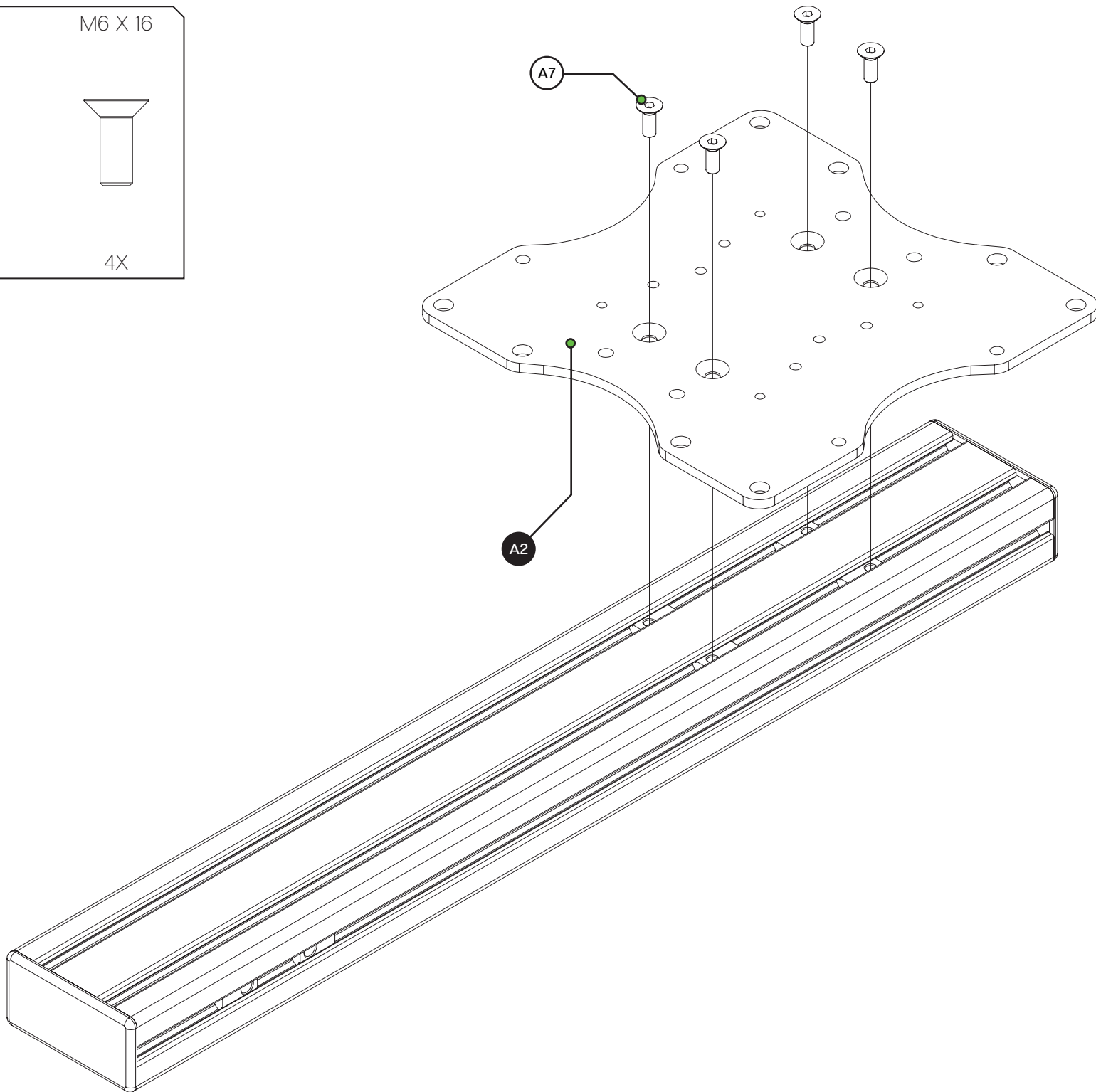

Screen Holder Plate

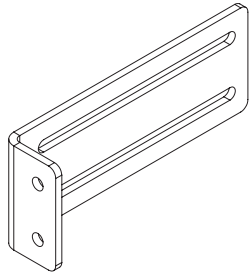

2X

M8 X 16

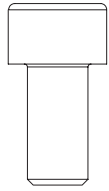

4X

Washer M8

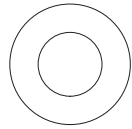

4X

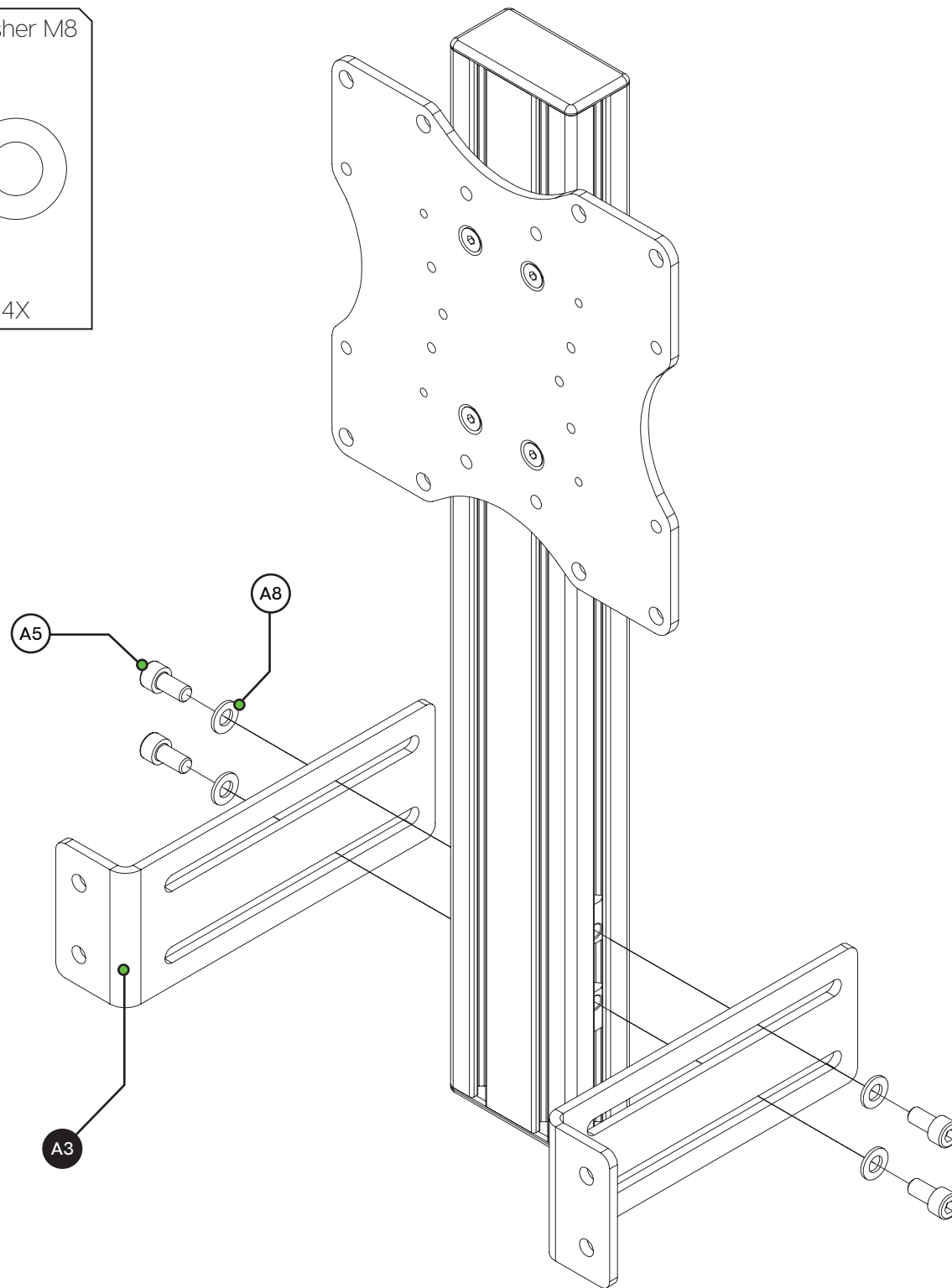

Slot-Nut M8

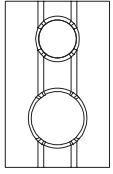

4X

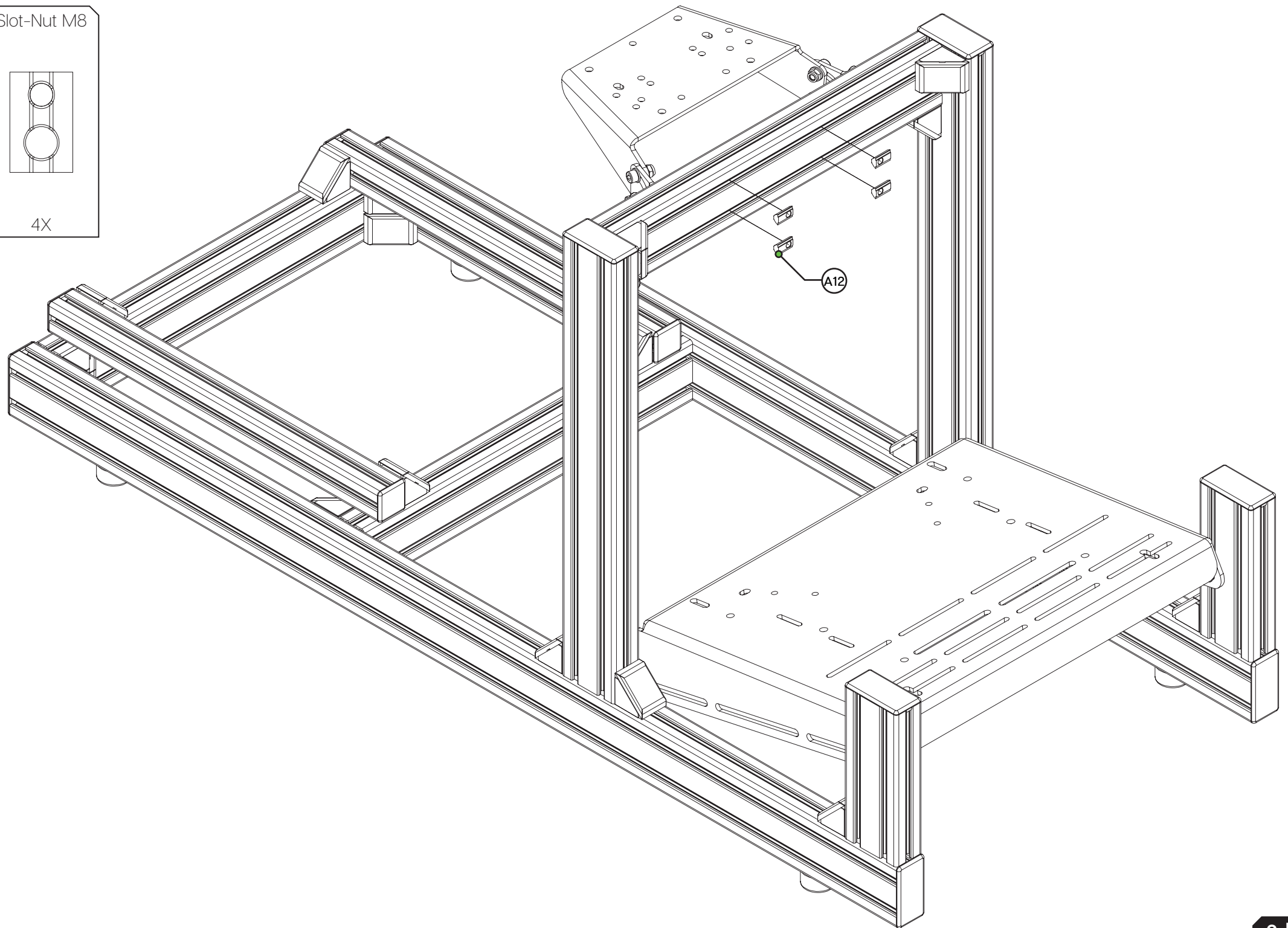

M8 X 16

Washer M8

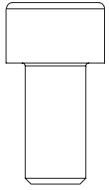

4X

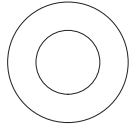

4X

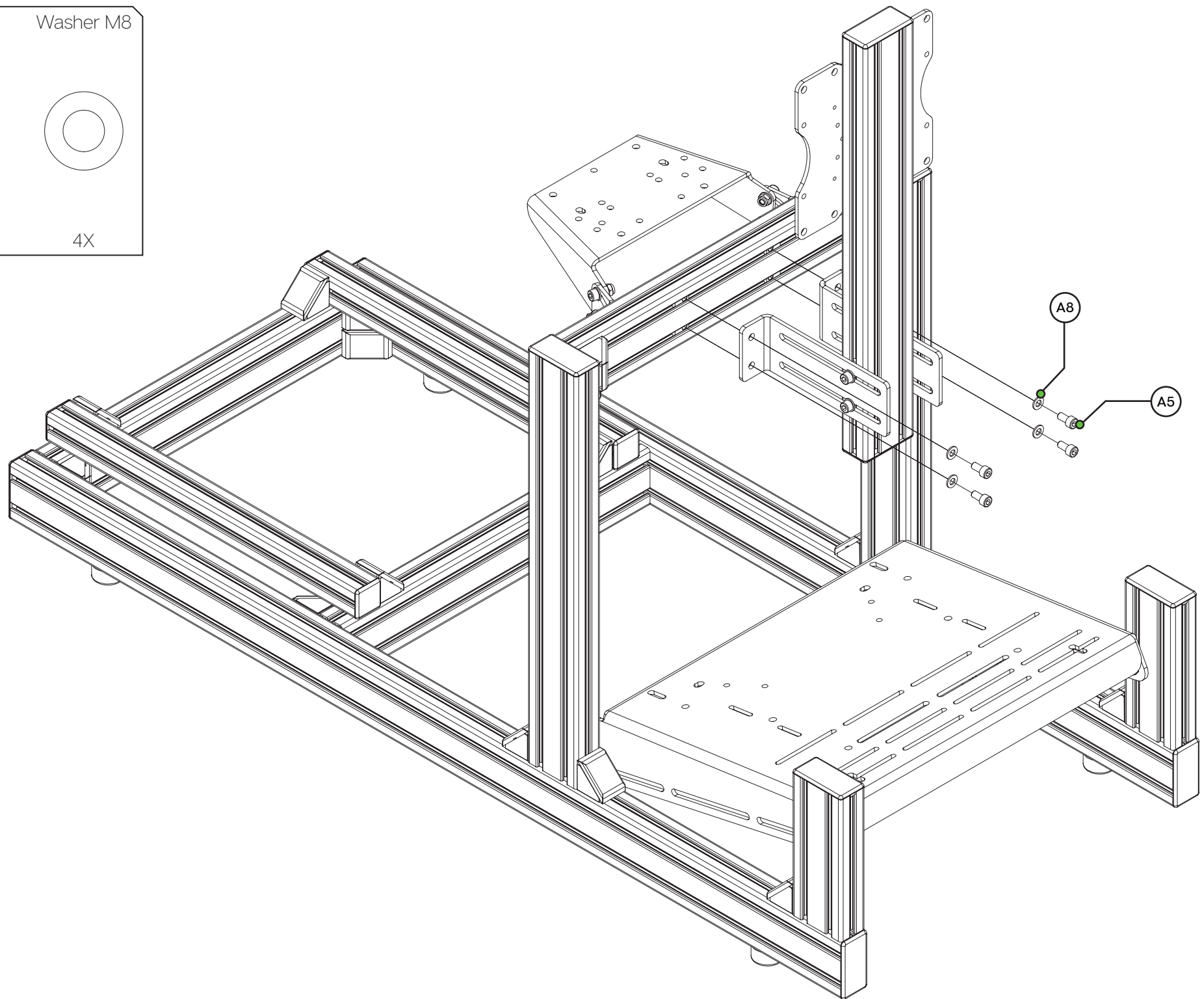

<b>PROFILE KIT</b>			
<b>#</b>	<b>Part</b>	<b>QTY</b>	<b>Note</b>
P1	80X40 Length=550mm	1	
<b>HARDWARE KIT</b>			
A2	VESA 200	1	
A3	Screen holder plate	2	
A4	Profile 80x40 end-cap	2	
A5	Bolt M8 X 16 DIN 912	8	
A6	Bolt M6 X 16 DIN 912	4	
A7	Bolt M6 X 16 DIN 7991	4	Countersunk
A8	Washer M8 DIN 125-A	8	
A9	Screw Philips M4 X 16 DIN 7985	4	Use to attach monitor to VESA bracket.
A10	Screw Philips M4 X 10 DIN 7985	4	Use to attach monitor to VESA bracket.
A11	Spacer male/female M4 X 10	4	Use as spacers for VESA bracket when the bracket doesn't clear the monitor.
A12	Slot-Nut M8	8	
A13	Slot-Nut M6	4	
<i>Disclaimer: for some entries on this list, we supply more than required as spare materials. Don't worry if you have some leftovers, this is intentional.</i>			



If you still have some questions regarding assembly of this product or about the manual itself, please refer to our support department. They can be reached at

support@sim-lab.eu

Alternatively, we now have a Discord server where there are quite some experienced Sim-Lab customers hanging out. They might just help you along if you ask them nicely ;)

[www.sim-lab.eu/discord](http://www.sim-lab.eu/discord)

If you feel like printing this manual, please consider the environment before doing so. For the best results, make sure you print at 100% scale without borders.

[Product page on the Sim-Lab website:](#)

