



**ADVENTURE  
FURTHER®**

## TIRE CARRIER MOUNT

JEEP -WRANGLER JL M14X1.5 (5X5)

BRONCO VI (U725) M12X1.5 (6X139.7MM)

RAPTOR M14X1.5 -(6X135MM)

# INSTALLATION INSTRUCTIONS

### IMPORTANT:

PLEASE READ ALL INSTRUCTIONS BEFORE BEGINNING INSTALLATION. THESE GUIDELINES ARE PROVIDED IN GOOD FAITH TO HELP PREVENT ANY ISSUES ARISING FROM ERRORS DURING INSTALLATION. THE MANUFACTURER OF THIS PRODUCT SHALL NOT BE HELD RESPONSIBLE FOR ANY USER ACTIONS TAKEN OR NOT TAKEN DURING INSTALLATION. THERE ARE MANY DETAILS OF THE INSTALLATION THAT ARE ASSUMED TO BE GENERAL MECHANICAL KNOWLEDGE TO EXPERIENCED INSTALLERS; WHICH ARE NOT DETAILED IN THESE INSTRUCTIONS. THESE INSTALLATION GUIDELINES ARE INTENDED TO SERVE AS PROFESSIONAL RECOMMENDATIONS AND ARE NOT AS A STEP-BY-STEP, FAIL-SAFE INSTALLATION CHECKLIST. SELECTION OF AN EXPERIENCED INSTALLER IS THE SOLE RESPONSIBILITY OF THE PROJECT OWNER.

FOR SPARE TIRE CARRIERS WITH TWO LUGS ABOVE THE CENTERLINE, 6 AND 5 LUG PATTERNS, MINIMUM 17" WHEEL. (FORD BRONCO / BRONCO RAPTOR AND JEEP JL)

TOOLS NEEDED:  
19MM HEX BIT AND SOCKET  
LUG REMOVAL TOOL

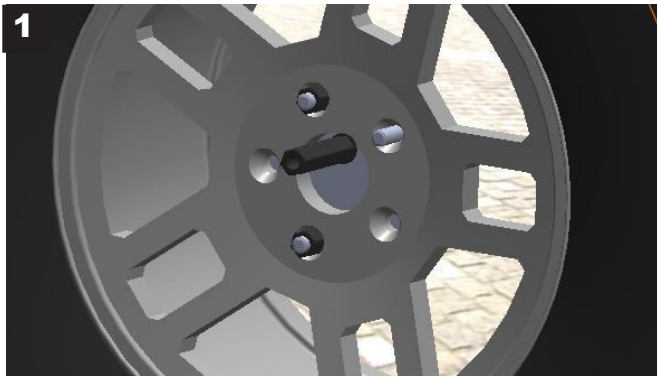

REMOVE 1 LUG NUT AT A TIME ON THE TOP 2 LUGS OF THE SPARE TIRE CARRIER, REPLACING WITH THE APPROPRIATE SPACER, THREAD PITCH AND LENGTH TO MATCH YOUR WHEEL OFFSET AND DESIRED LOOK.

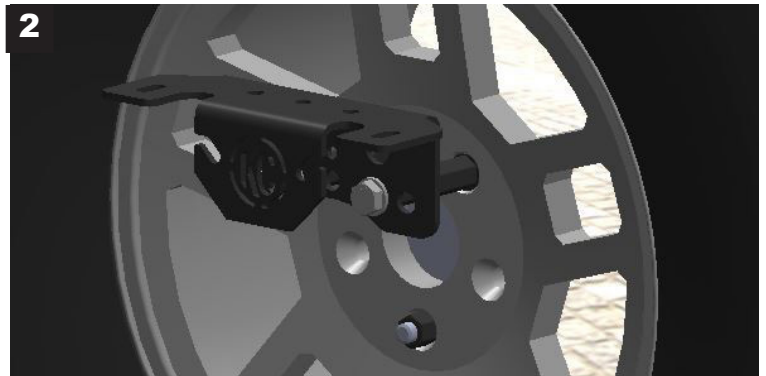

TEST FIT THE BRACKET FOR GETTING THE CORRECT SPACER LENGTH FOR YOUR SETUP, USING (2) M12 HEX BOLTS AND WASHERS.

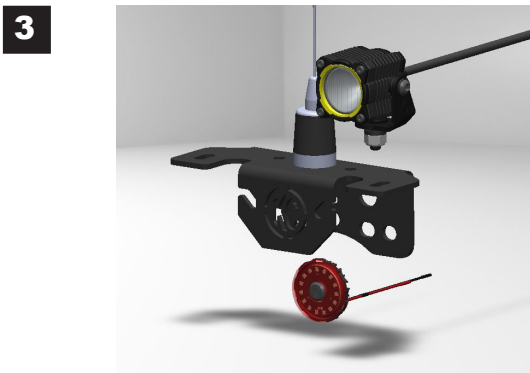

REMOVE THE BRACKET TO INSTALL THE FE1S AND ANY OTHER PIECES AS DESIRED. (RED CYCLONE V2, ANTENNA MOUNT, ETC.)

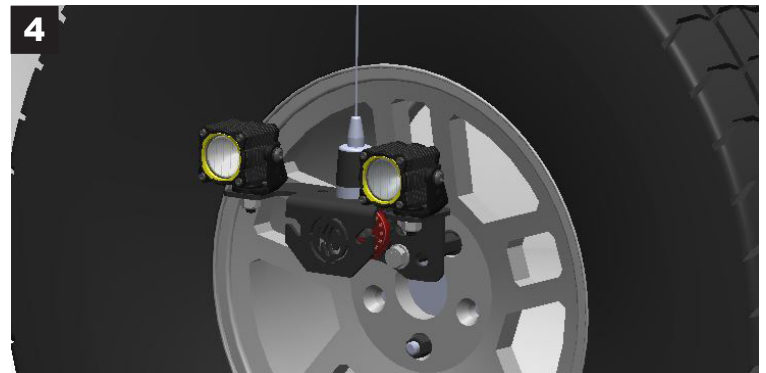

REINSTALL THE BRACKET AND TIGHTEN ALL FASTENERS.

FOR THE WIRING OF ANY LIGHTS, PLEASE FOLLOW THE DIRECTIONS SUPPLIED WITH THE LIGHTS.  
PLEASE NOTE THAT SOME JEEP JL MODELS WILL REQUIRE THE BACK UP CAMERA TRIM REMOVED WITH THE JEEP TOOL KIT THAT COMES WITH THE JEEP OR WITH A T40 TORX BIT.