

# Sleavon

## Home Dehumidifier

Please read the manual carefully  
before using the unit

**D023H**

USER MANUAL



## FOR CUSTOMERS

Thank you for purchasing our dehumidifier.

**Sleavon** wishes that our products and services can bring convenience to your work and life. We highly recommend that you keep the manual for reference if you encounter unexpected events using the unit.

Please read the manual carefully to ensure proper use of the dehumidifier. Our dehumidifiers are widely used in family bedrooms, bathrooms, basements, offices and storage rooms, etc.

The dehumidifiers from **Sleavon** provide quick and efficient operation to reduce room's humidity and bring you a healthy and comfortable life.

## TO ACCESS CUSTOMER SUPPORT FASTER

If there is any problem of the product, please contact Sleavon Customer Service at [support@sleavon.com](mailto:support@sleavon.com) with your Purchase Order ID to help you address the problem more effectively.

# BEFORE FIRST USE:

To prevent any internal damage, it is very important to keep refrigeration units (like this one) upright throughout their journey.

Please leave it standing upright and outside the box for **24 HOURS** before plugging it in.

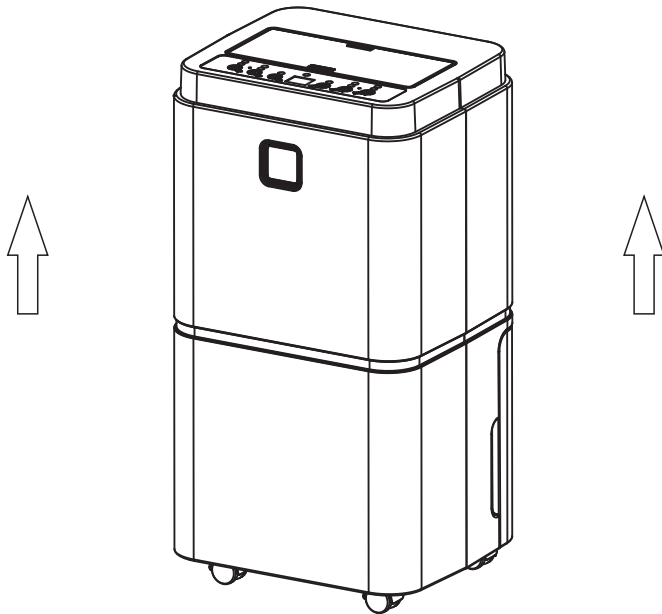

# TABLE OF CONTENTS

**SAFETY INSTRUCTIONS .....1**

**FEATURES & SPECIFICATIONS.....2**

**PRODUCT DRAWINGS .....3**

**MACHINE SETUP & OPERATION .....4**

**WATER DRAINAGE .....7**

**MAINTENANCE & STORAGE.....10**

**TROUBLE SHOOTING.....11**

**SPECIAL NOTES.....12**

**WARRANTY & CONTACT US .....13**

# SAFETY INSTRUCTIONS

## IMPORTANT NOTICE FOR FIRST USE :

For your safety, please read the manual carefully and keep the manual for future reference. Please use this product according to the instructions of installation and operation of this manual.

Don't try to repair, dismantle or modify this appliance, or it may cause damage.

- Install the unit on flat and hard floor to diminish vibration or noise.
- Never immerse the unit in water or other liquids.
- Never operate the unit if the cable or other connector is damaged, or something abnormal that happened, please call customer service for help.
- Disconnect the unit from power supply when it is not in use, or before relocating or cleaning it.
- Operate the unit only at the voltage specified.
- The unit is for indoor use only. Don't use it for other purpose.
- Do not put heavy objects on the appliance.
- Do not tip the unit to any side as spilled water may damage the appliance.
- Never insert any other objects into the unit body to avoid any hazard or unit failure.
- Do not put the unit close to heat-generating devices or near flammable and dangerous materials.
- This appliance is not intended for use by persons (including children) with reduced physical, sensory or lack of experience and knowledge, unless they have been given supervision or instructions concerning use of the appliance by a person responsible for their safety. Children should be supervised to ensure that they do not play with the appliance.
- If the supply cord is damaged, it must be replaced by the manufacturer or its service agent or a similarly qualified person in order to avoid a hazard.
- The appliance must be placed properly so that the plug is accessible.
- The appliance shall be installed in accordance with national wiring regulations.
- The ambient temperature range for the appliance is 41°F- 95°F.

## FEATURES & SPECIFICATIONS

### PRODUCT FEATURES

- 40 pints per day, efficient dehumidification
- Three optional modes (AUTO,CNT,SLEEP)
- Compact and modern design
- Extremely quiet operation(36dB(A))
- Auto defrosting

### SPECIFICATIONS

|                              |                         |
|------------------------------|-------------------------|
| Model No.                    | D023H                   |
| Power Source                 | AC115V 60Hz             |
| Rated Power(86°F,80%RH)      | 195W                    |
| Rated Current(86°F,80%RH)    | 2.0A                    |
| Moisture Removal(65°F,60%RH) | 9 Pints/Day(4.2L/Day)   |
| Moisture Removal(80°F,60%RH) | 13 Pints/Day(6.1L/Day)  |
| Moisture Removal(86°F,80%RH) | 24 Pints/Day(11.3L/Day) |
| Moisture Removal(95°F,90%RH) | 32 Pints/Day(15.1L/Day) |
| IEF(65°F,60%RH)              | 1.46liters/kWh          |
| HIGH PRESSURE                | 204psi(1.41Mpa)         |
| LOW PRESSURE                 | 88psi(0.60Mpa)          |
| Noise                        | ≤36dB(A)                |
| Refrigerant / Charge         | R134a 3.70oz            |
| Working Temp.                | 41°F - 95°F             |
| Product Dimensions           | 10.0*8.5*19.5in         |
| Net Weight                   | 10.4kg/23 lbs           |

#### WARNING

This product can expose you to chemicals including Styrene and its compounds, which are known to the State of California to cause cancer and birth defects or other reproductive harm. For more information, please visit: [www.P65Warning.ca.gov](http://www.P65Warning.ca.gov).

# PRODUCT DRAWINGS

## Front

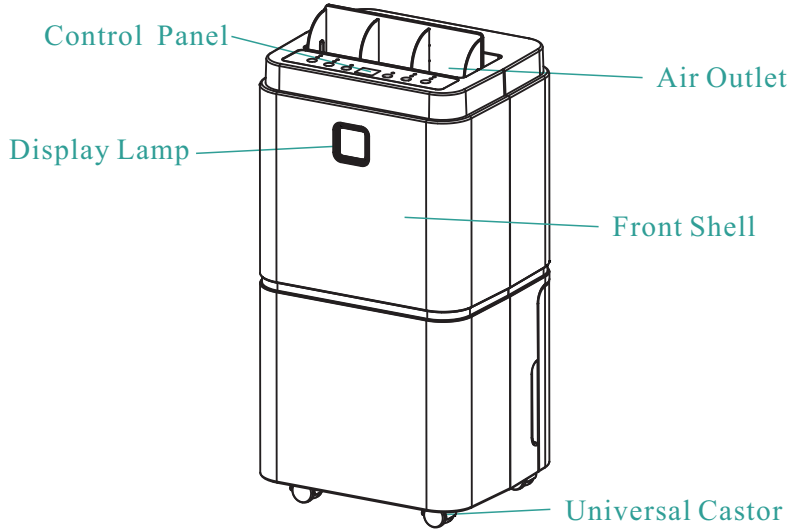

## Back

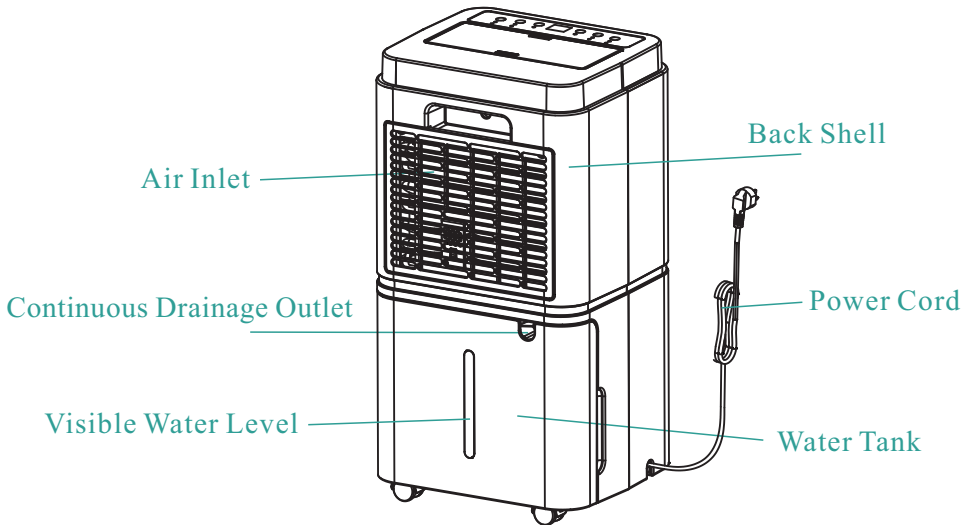



## DIGITAL DISPLAY



humidity<45%



45%≤humidity≤65%



humidity>65%

## OPERATIONS

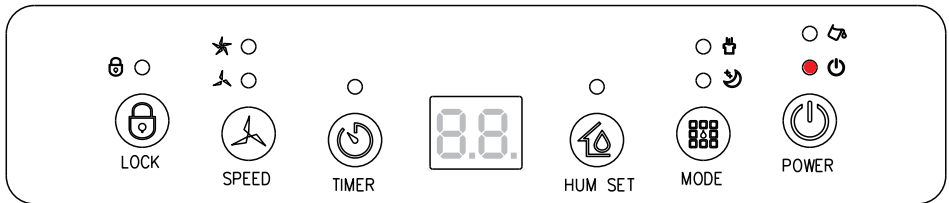

## Button Function

### 1. Power

After plugging the power, the “POWER” indicator will light up, the machine is in standby mode.

In this mode, press the “POWER” button to turn on the machine, it will enter the Auto Mode automatically, the “HUM SET” indicator will light up, the fan will run at default high wind speed, and the default humidity value is 50%RH.

In running status, press this “POWER” button, the compressor will stop immediately, and the fan will shut down after 30 seconds’ delay, all indicators except the "POWER" indicator will be off, the machine will be back in standby mode.

### 2. Modes

Auto Mode—Continuous Drying Mode—Sleep Mode Switch, press the “MODE” button to switch the mode from one to another, the corresponding indicator will light up.

# MACHINE SETUP & OPERATION

## ● Auto Mode

Both the fan speed and the humidity value can be adjusted under Auto Mode, and the “HUM SET” indicator will light up at this mode.

When environmental humidity  $\geq$  set humidity by 3%RH, the fan will start to work and compressor will start 3 seconds afterwards. When environmental humidity  $\leq$  set humidity by 3%RH, the compressor will stop working, the fan will stop after 30 seconds' delay.

## ● Continuous Drying Mode

The machine continues to run, but the humidity can not be adjusted at this mode, the sleep indicator “” will light up.

## ● Sleeping Mode

Neither the fan speed nor the humidity value can not be adjusted under sleeping mode. Press the “MODE” button you can choose the Sleep Mode, the sleep indicator “” will light up and start this function.

If no operation within 10 seconds, all indicators will turn dark gradually and the wind speed is automatically switched from high to low. You can press any button to wake up the indicator. Press the “MODE” button again will exit the Sleep Mode.

When environmental humidity  $\leq$  57%, the compressor will stop working and the fan will shut down after 30 seconds' delay. When environmental humidity  $\geq$  63%RH, the fan will start working and compressor starts after 3 seconds.

## 3. Timer

The timing function is designed for you to automatically turn on (when the machine is off), or to turn off (when the machine is on) the machine by the timer.

Press the timer button you can set the timer within the range of 0-12 hours at the interval of 1 hour. Each time you press this button, the value will increase by 1 hour and the corresponding timing value will be displayed on the screen.

When you set the timer, the setting time will flash on the screen to show the setting value.

If you successfully set the timer, the timer indicator will be on, and the screen will display the setting time when you press the “TIMER” button again.

If you set the timing value to “00”, it is called the invalid setting time or to cancel the timing function.

## MACHINE SETUP & OPERATION

### 4. Humidity Setting

HUM SET

Press the humidity button you can check the current environment humidity, and press again you can set the humidity. The range of target humidity is:

**30%- 35% - 40% - 45% - 50% - 55%- 60% - 65% -70% - 75%- 80%.**

After setting for 3 seconds, the system will confirm the input value, then the machine will exit the setting status, and return the current humidity.

In the Drying Mode, the target humidity cannot be changed.

Long Press humidity button for 3 seconds will display the current ambient temperature.

### 5. Fan Speed

SPEED

High Wind - Low Wind Switch, press this button once to switch the fan speed, then the corresponding indicator will light up.

In Continuous Drying Mode, Sleep Mode and defrosting period, the wind speed can not be changed.

### 6. Child-lock

LOCK

Long press the button for 3 seconds to turn on/off the child-lock function.

## WATER DRAINAGE

### Water Tank Full Alarm

When the tank is full for 5 seconds, it activates the Full Tank Alarm. The Full Tank indicator will turn red and the unit will buzz for 5 times.

#### Clear the alarm

When the buzz is on, press any button to stop it. The compressor and fan will shut down, and all the functions will freeze until the tank is emptied and put back in right position.

#### Empty the tank

Grab the notch at the bottom of the tank and pull it out with both hands.

Take it out slowly and steadily in case spilling water.

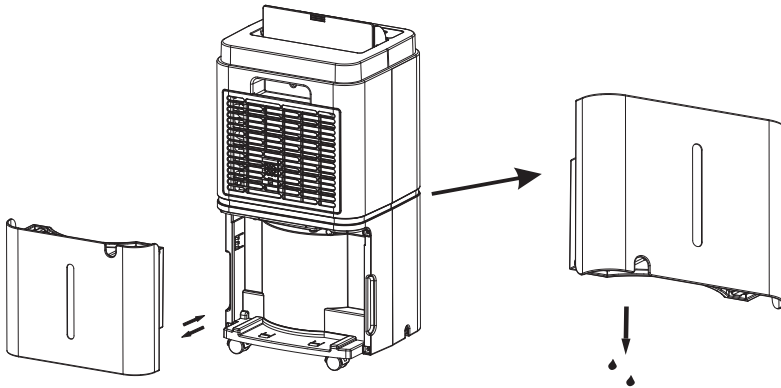

Empty the water.

Put the water tank back in position, the dehumidifier will automatically start working again.

# WATER DRAINAGE

## PRECAUTIONS

- 1** Do not remove the float out of the tank otherwise the dehumidifier can not start up.

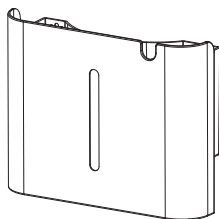

- 2** Ensure the water tank is in right position when putting it back, otherwise the dehumidifier can not start up.

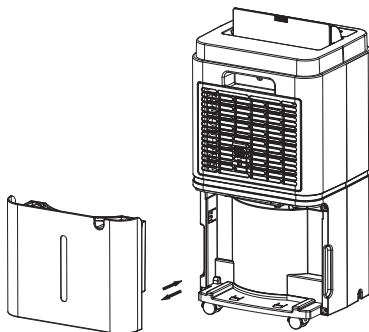

- 3** If the tank is dirty, wash it with cool/warm water. Do not use detergent, steel balls, chemically treated dustproof cloth, gasoline, benzene, thinners or other chemical solvents in case damage and leakage.

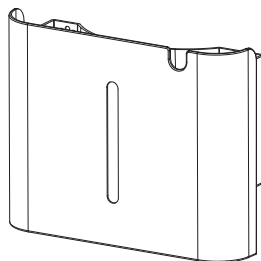

- 4** **Working Distance**

When the dehumidifier is in operation, make sure that the front and rear of the dehumidifier maintains a minimum working distance of 20 cm from the surrounding objects.

## WATER DRAINAGE

### CONTINUOUS DRAINAGE

- Take out the water tank

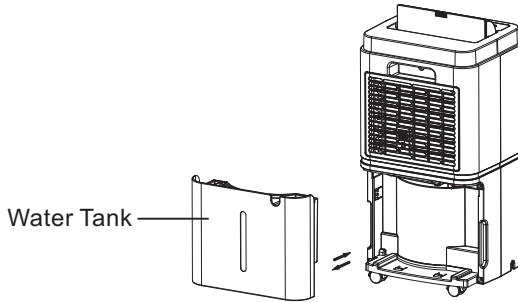

- Use a water hose to connect the water outlet.
- Dress the water hose through the cutting hole in the tank and push the tank back to the machine.

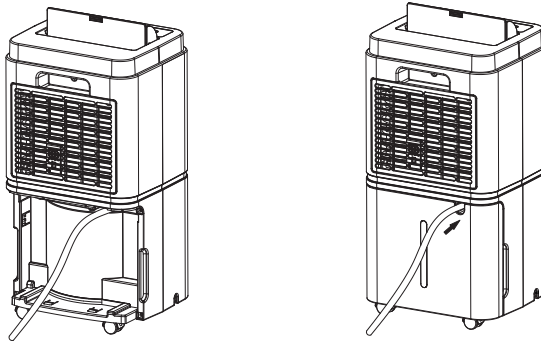

- For continuous drainage, the drainage end of the hose should not be submerged in water in case being blocked or damaged.

## MAINTENANCE & STORAGE

### MAINTENANCE

#### Body Cleaning

Use a soft and slightly wet cloth to clean the dehumidifier body.

#### Filter Cleaning

1. Take off the filter mesh.
2. Use a vacuum cleaner to gently absorb the dust on the surface. If the filter is very dirty, wash it with water and a soft cloth and dry it thoroughly afterwards.
3. Put the filter back.

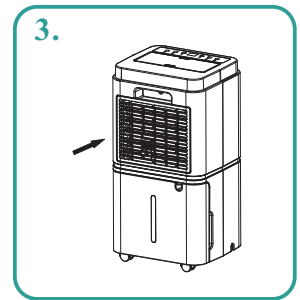
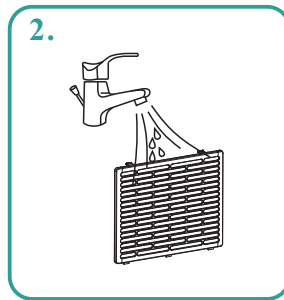
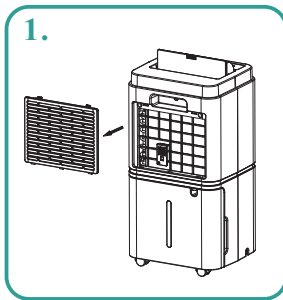

### STORAGE

When not using the product for a long time and intend to store it, please pay attention to the following steps:

1. Empty the water in the water tank and wipe the water droplets at the bottom of machine inside.
2. Roll up the power cord and tie it up.
3. Clean the filter.
4. Place the machine in a cool and dry environment.

# TROUBLE SHOOTING

## FUNCTIONING TEMP.

41°F ≤ Ambient Temp. ≤95 °F

When the ambient temp. is lower or higher than the functioning temp., the dehumidifier will stop operating.

When the machine is working between the ambient temperature of 41°F and 60.8°F, the compressor will automatically defrost at intervals. When defrosting, the compressor will stop and the fan will keep running.

## BEFORE CALLING FOR CUSTOMER SERVICE

Before contacting the professional service, you can take a time to review the Trouble Shooting List that includes common occurrences that are not the result of defect in workmanship or materials as below.

| Problem                 | Possible Cause   | Solution   |
|-------------------------|--|--|
| Not working             | No power supply.   | Connect to a functioning outlet and switch on.                                     |
|                         | Water full indicator flashes.                                    | Drain water tank and reset it, or re-position the water tank to right place.       |
| Not very effective      | Room temperature < 41°F, or > 95°F.                              | Self-protection designed to protect the unit. Can not work under such temperature. |
| Bad functioning         | Is the air filter clogged?                                       | Clean the air filter as instructed.  |
|                         | Is the intake duct or discharge duct obstructed?                 | Remove the obstruction from the discharge duct or intake duct.                     |
| No air intake           | Is the filter clogged?   | Wash the filter.   |
| Loud noise when running | Is the machine put in the plat place?                            | Put the machine on the plat ground.  |
|                         | Is the filter clogged?   | Wash the filter.   |
| E2                      | Humidity sensor problem.   | Change a sensor.   |
| LO                      | Environmental humidity is below 20%.                             | The dehumidifier shuts down for self- protection.                                  |
| HI                      | Environmental humidity is above 90%.                             |  |
| CL                      | Low temperature protection, the environmental temperature<41°F.  |  |
| CH                      | High temperature protection, the environmental temperature>95°F. |  |



## SPECIAL NOTES



- 1 When using, please do not put the machine at the soft and uneven ground, avoid vibration and movement.



- 2 Do not insert thin rods and hard objects into the machine body to avoid malfunction and danger.

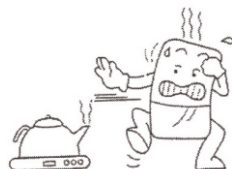

- 3 When using, please keep the machine away from heating furnace, electric kettle and other heat sources.



- 4 When using, please close doors and windows to achieve the best remove humidity effect.



- 5 Please do not put objects around the body. If the ventilation is blocked, the dehumidification effect will be affected.



- 6 If do not use the product for a long time, please unplug the power cord.



- 7 When cleaning the dehumidifier, please use the wet textile to wipe gently, do not shoot the water directly.

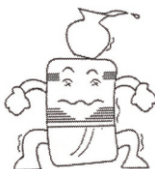

- 8 Please do not put any object on the dehumidifier.



- 9 Please clean the filter every two weeks (do not use hot water above 104°F, alcohol, gasoline or toluene.)



- 10 When continuous drainage, the drain hose must be placed horizontally, without unevenness and winding.



- 11 After cleaning the filter, please do not dry it under direct sunlight, in case deformation.



- 12 Before moving and carrying the machine, please first pour out the water in the tank.

## WARRANTY & CONTACT US

### Warranty

---

Sleavon offers a 12-month warranty to all of our products together with the original proof of purchase when a defect occurred, including those newly purchased and unused, from Sleavon or through an authorized reseller, wholly or substantially, or as a result of faulty manufacturing parts, or workmanship during the Warranty Period.

The warranty does not apply if damage is caused by other factors, including but without limitation of:

- (a) Normal wear and tear;
- (b) Abuse, mishandling, accident or failure to follow operating instructions;
- (c) Exposure to liquid or infiltration of foreign particles;
- (d) Servicing or modification of the product other than by Sleavon.

There are our general terms for the warranty service, but we always encourage our customers to contact us if any issues, regardless of warranty terms.

If you are experiencing an issue with Sleavon product, you can reach out to us at [support@sleavon.com](mailto:support@sleavon.com), we will dedicate our efforts to resolve it for you.

### Extend Your Warranty by 1 Year

---

Register your product at [www.sleavon.com](http://www.sleavon.com) to extend your 1-year warranty by an additional year.

\*Please fill out all required fields and include your Order ID, Date of Purchased if applicable.

### Customer Support

---

If you have any questions or concerns about your product, please feel free to contact our expert support team. Sleavon customer service is here to help.

#### **Sleavon Office**

13211, Spring Street Baldwin Park, CA, US

Email: [support@sleavon.com](mailto:support@sleavon.com)

Live Chat: [www.sleavon.com](http://www.sleavon.com)

#### **Support Hours**

24 Hours available

\*Please have your Order Number ready before contacting customer support.



# Sleavon

For FAQs and more information please visit:  
[www.sleavon.com](http://www.sleavon.com)



@ Sleavon



@ Sleavon



@ Sleavon



@ Sleavon



(Scan the QR Code for Live Chat)

We are expecting to see our products fulfill your life and hear your voice.

Your satisfaction means a lot to us.

Please tag us if you share a snap on your social media.

[www.sleavon.com](http://www.sleavon.com)