

N2LOK

Hardware Trading Pty Ltd

Maison
SERIES

LIMITED WARRANTY
7 YEAR MECHANICAL

LIMITED WARRANTY
5 YEAR FINISH

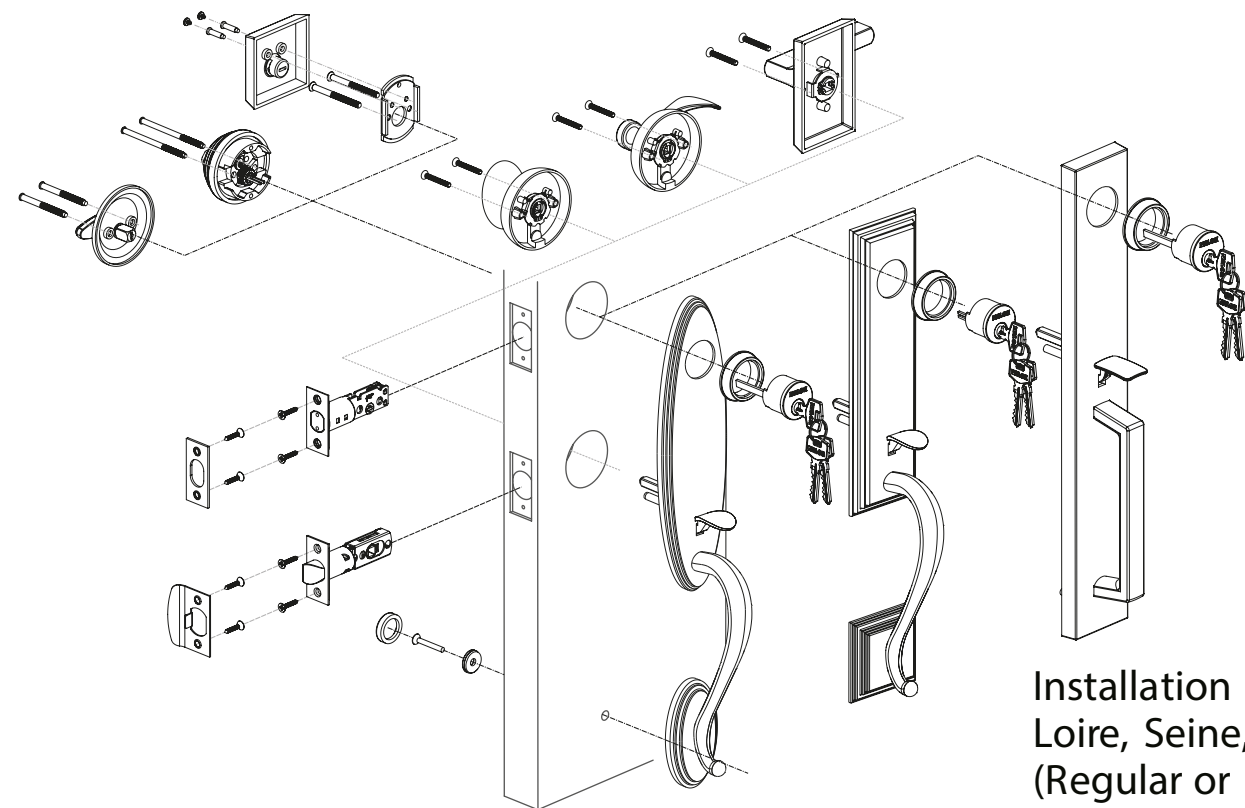

Installation Instructions for Loire, Seine, Montpellier Handleset (Regular or Interconnect Set)

Door Preparation

A. Mark Door
Use template enclosed to mark off installation holes on both sides of door. Mark locations for the 25.4mm (1") diameter holes in center of door edge. Check backset desired, mark appropriate center for 54mm (2-1/8") diameter holes and 9mm (11/32") diameter hole on door face.

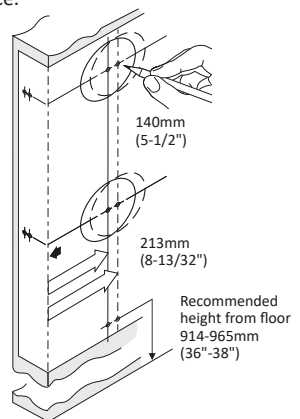

B. Drill Holes
Bore 54mm (2-1/8") holes about halfway through door, then finish drilling from the other side to prevent Splintering.

Drill the 9mm (11/32") hole for the bottom mounting screw for the handle.

Drill the 25.4mm (1") holes for about 51mm (2") deep in the door edge for latches.

Note: For Dummy, no need for latch holes.

Functional Handleset **Dummy Handleset**

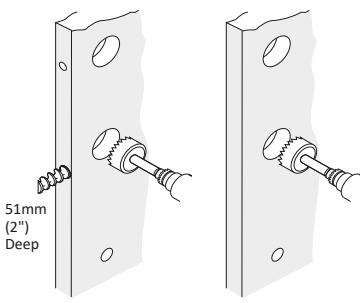

C. Chisel cavity for Latch & Strike
Insert latches into the holes, keeping the face plate parallel to the edge of door. Mark outline and remove latches.

Chisel 4mm (1/8") deep or until the face plate of latch is flush with the door edge.

Note:
No chiseling is required for latch if you are using a drive in latch. (Latch without face plate)

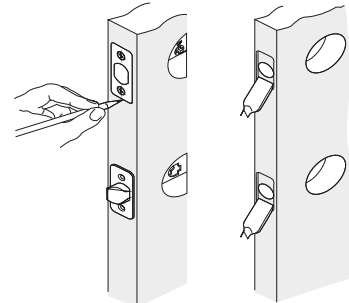

For Deadbolt Latchbolt at the top center, mark outline on the Door Jamb, using a 22mm (7/8") diameter Drill Bit to drill the Door Jamb to a depth of 25.4mm (1").

For Passage Spring Latch at the bottom center, mark outline on the Door Jamb, using a 22mm (7/8") diameter Drill Bit to drill the Door Jamb to a depth of 13mm (1/2").

Chisel outline for strike plates 1.5mm (1/16") deep or until the striker plates are flush with the door jamb.

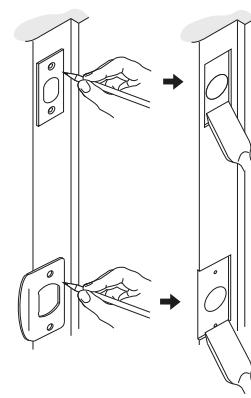

Latch Preparation

Measure your door for a backset of 60mm (2-3/8") or 70mm (2-3/4"). If backset of door measured 70mm (2-3/4") adjust latch as shown.

Deadbolt Latch

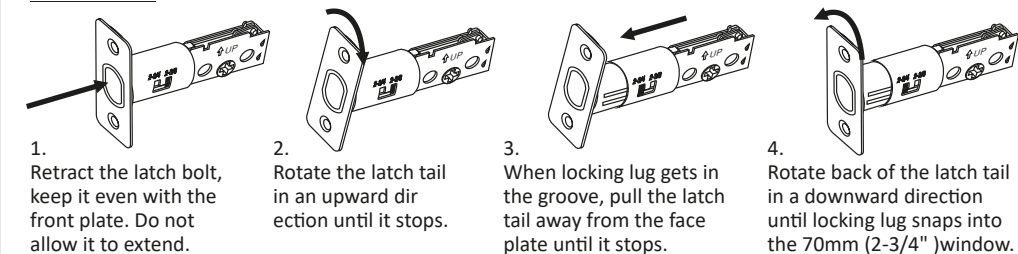

Spring Latch

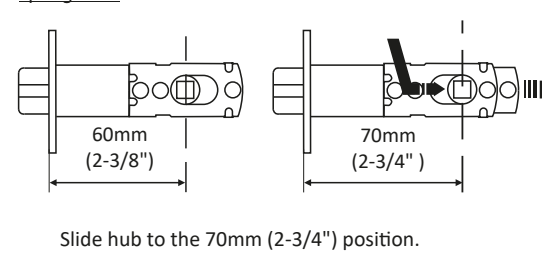

Installation Instructions

D. Install Latches

Insert deadbolt latch in up position into hole as shown. With the "UP" at the top. Secure with screws.

Insert latch with the slant of bolt facing in the direction that the door closes. Secure with screws.

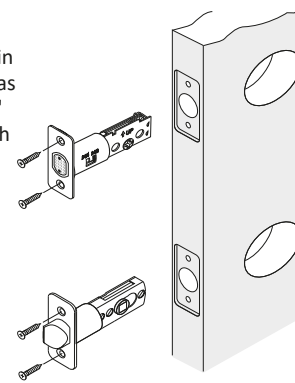

E. Install Exterior Assembly

Functional:
Place Exterior Handle with stems and square spindle into the spring latch as shown, press tightly against door face.

Install exterior deadbolt cylinder with the torque blade vertically insert into latch crank.

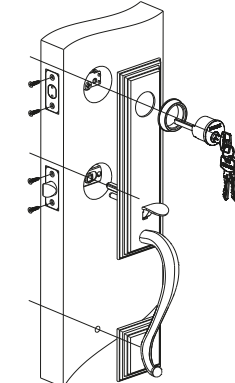

Dummy:
Place Exterior Dummy Handle with stems get into the drilled hole; put the Dummy cylinder into the cylinder hole on the handle.

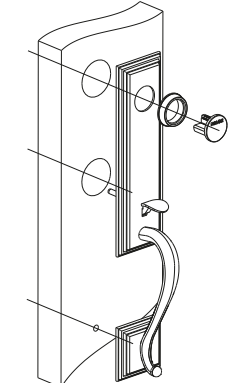

F. Install Interior Assembly - For Regular Handlesets

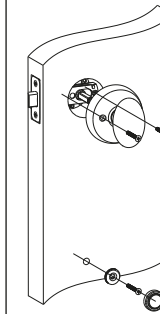

After the Exterior Handle is in place, install Interior Knob or Lever assembly, then tighten the fixing screws.

Install screw through washer into the bottom hole, tighten the fixing screw, then put the screw cap.

For Single Cylinder Models:

Place turnpiece assembly on door, rotate turnpiece to vertical position, insert screws, engaging exterior cylinder and tighten.

For Montpellier Model

Place the Fixing Plate on door, insert screws, engaging exterior cylinder and tighten. Then place Turn Snib Assembly on door, keep the Turn Snib on horizontal position, insert shorter screws and tighten the assembly.

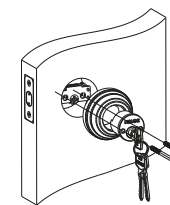

For Double Cylinder Models:

Install the internal Cylinder & Rose assembly with the Torque Blade horizontally insert into the Latch Bolt Crank. The Key Way should be at the 6:00 o'clock position.

Install Interior cylinder assembly, insert the fixing screws, engaging exterior cylinder and tighten.

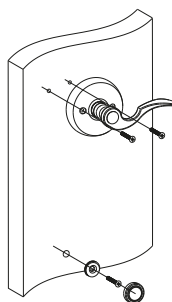

For Dummy Handleset Models:

Install Interior Dummy Knob or Dummy Lever assembly, then tighten the fixing screws.

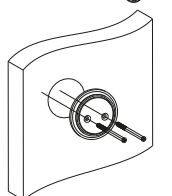

Place Interior Dummy deadbolt assembly on door, insert screws, engaging exterior dummy cylinder and tighten.

G. Install Interior Assembly - For Interconnect Sets

Place Interior Lever Escutcheon Assembly on door, rotate turnpiece to horizontal position to engage with the torque blade from the exterior cylinder; lever section to engage with the spindle from the exterior assembly, then insert fixing screws and tighten.

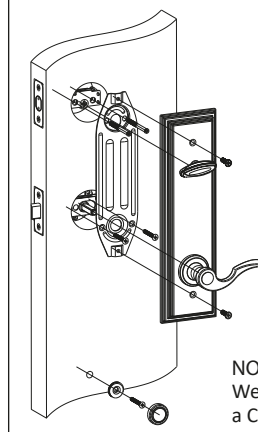

For Dummy Handleset Models:

Install Interior Dummy Lever Escutcheon Assembly, then tighten the fixing screws.

When installing the interconnect set, make sure:

1. Install the Deadbolt Latch with the bolt in the retracted position.
2. Turn the turnsnib to the horizontal position.
3. Turn the torque blade of the Exterior Cylinder to the vertical position and insert to the receiving hole of the turnsnib through the latch.

NOTE: Do not overtighten the fixing screws. We recommend you use a Screw Driver not a Cordless Power Driver.

To re-hand the Lever

Use the Alle/Hex Key tool provided to release the Allen/Hex screw from underneath of the lever neck, remove cover pin and the lever, then reverse the Lever, put the lever and the cover pin back in place then retighten the Allen/Hex screw.

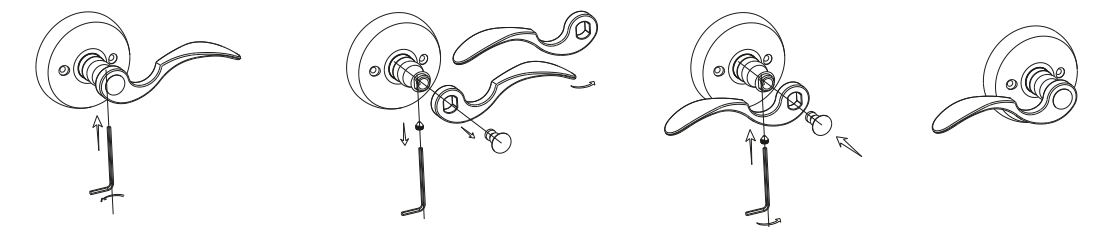

This product is warranted to be free from mechanical & workmanship defects for 7 years and free from finish & surface defects for 5 years from the original date of purchase. Should a mechanical or finish defect occur within this warranty period just return the product along with proof of purchase to point of purchase for replacement. Premature finish deterioration due to the use of solvents, acid cleaners, paints, climatic conditions i.e. salt air or surface abrasion by keys or jewellery is not considered a defect & thus not covered by this warranty. The same applies for mechanical failure due to the incorrect installation, misuse or abuse will not be covered by this warranty. The removal & refitting of the product & any associated handling & transportation costs is not covered by this warranty. N2LOK reserves the right to modify product styles & finishes without notification. If the same product model is no longer available a similar product model will be supplied. Any accessories, spare parts & trim purchased separately to complete & compliment the lockset or hardware are not covered by this warranty.

LIMITED WARRANTY
7 YEAR MECHANICAL

LIMITED WARRANTY
5 YEAR FINISH