



MODEL:132908

W4xL12xH2.4M
Enclosed Livestock Shelter

ASSEMBLY MANUAL





Installation Instructions

Thank you for your order of our 8 x 4 x 2.4m Enclosed livestock shelter. This unit is a combination of excellent manufacturing and design. It is comprised of a rigid frame and a durable cover. For easy assembly, we have marked all the parts with codes. With proper installation, use, and maintenance, your unit will provide many years of suitable service.

Tools Required

The following hand tools will be needed for the proper installation of your new building:

- 12mm, 14mm, and 17mm open-end wrenches
- 12mm, 14mm, 17mm sockets or box wrenches
- Large flat-head screwdriver
- 2lb maul or sledgehammer
- 4ft level
- 14ft step ladder
- Stake and string for aligning base plates and frame

Assembly Procedure

1. Prepare the location and place all unit boxes near the location sight. Perform an inventory check before beginning, to be certain all components are available for installation.
2. Secure base plate flanges to the base surface.
3. Assemble every group of the arch.
4. Begin frame assembly with front end arch, first interior arch, purlins, etc.
5. Add to assemble other groups of arches.
6. Install the main cover over the frame.
7. Install end cover over end panels.

Read all the detailed instructions and notices in the following assembly instructions!



Maintenance and Care

1. If some parts of the cover are accidentally damaged during the installation, Please contact us in regards to repairs/replacements so we can prevent the shelter from further damage and keep the building in a good condition.
2. When replacing the parts, make sure that the whole frame and the parts connected to the replaced parts are well fixed or supported.
3. Choose a windless day to replace the cover.
4. Start with making sure that all the bolts of the frame and the tensioning equipment is well fixed. When taking off the cover, make sure that the related ropes, etc are taken off, and the cover will not be blocking anything.
5. Avoid taking off the cover with any heavy machinery.
6. To elongate the life of the cover, you can put small duct tape or anti-friction patches (provided by yourself) on the section of the frame that comes in contact with the cover. The tape or patch acts as a cushion to avoid rubbing damage to the cover over the years.
7. Every few months, the building should be completely inspected and maintained internally and externally to make sure that the building remains properly installed and secured. This includes:
 - Checking all bolts and hardware connectors to be sure that they are in place and tightened
 - The base plates are still fixed firmly
 - Check and adjust the ropes if in need
 - Clean the cover with suitable washing. (If dirt and debris sit on the cover for too long, this can cause damage)

Thanks again for choosing this quality product. The following is the detailed assembly instructions for you starting the assembly.

Code	PART LIST	Quantity
1	Top roof tube	7
2	Shoulder tube	14
3	Sidewall tube	10
3A	Sidewall tube for front and back panel	4
4	Horizontal tube	30
5	Base plate	17
5A	Base plate for front panel	1
6	Upper vertical tube for front panel	2
6A	Upper vertical tube for back panel	1
7	Lower vertical tube for front panel	2
7A	Lower vertical tube for back panel	1
8	Rails	28
8A	Rail door	2
8B	Rails beside the door	4
9	Stake pegs	36
10	Locker of the door	2
10A	Connectors for door	1
11	Clips	2
12	Hexagon bolts M8*50	96
13	Carriage bolts M8*55	75
14	Hexagon bolts M8*60	40
14A	Hexagon bolts M8*25	3
15	Roof cover	1
16	Cover for back panel	1
17	Cover for sidewall	2
18	Rope for cover installation	6
19	Tensioning tube for roof cover	2sets
20	Band for plastic tube ratchet	14
21	Ratchet for plastic tube	14

Part#1 7PCS

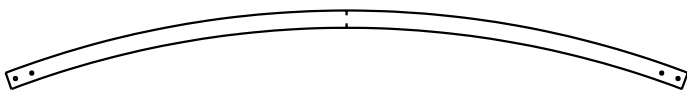

Part#2 14PCS



Part#3/3A 10/4PCS

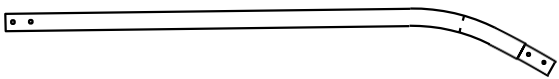

Part#4 30PCS

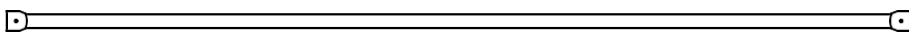

Part#5 17PCS

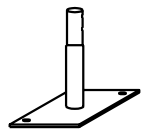

Part#8A 2PCS

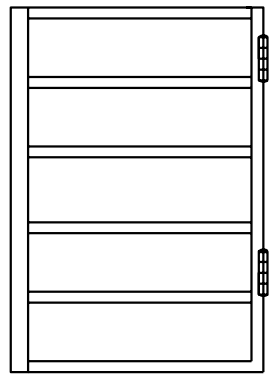
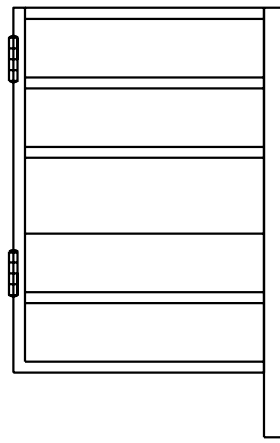

Part#19 4PCS

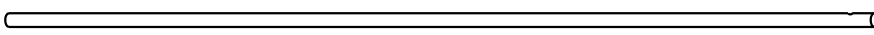

Part#7/7A 2/1PCS

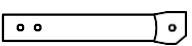
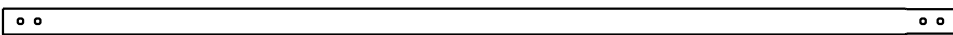

Part#6/6A 2/1PCS

Part#8B 4PCS

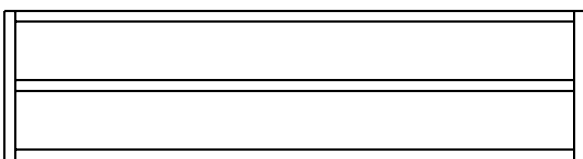

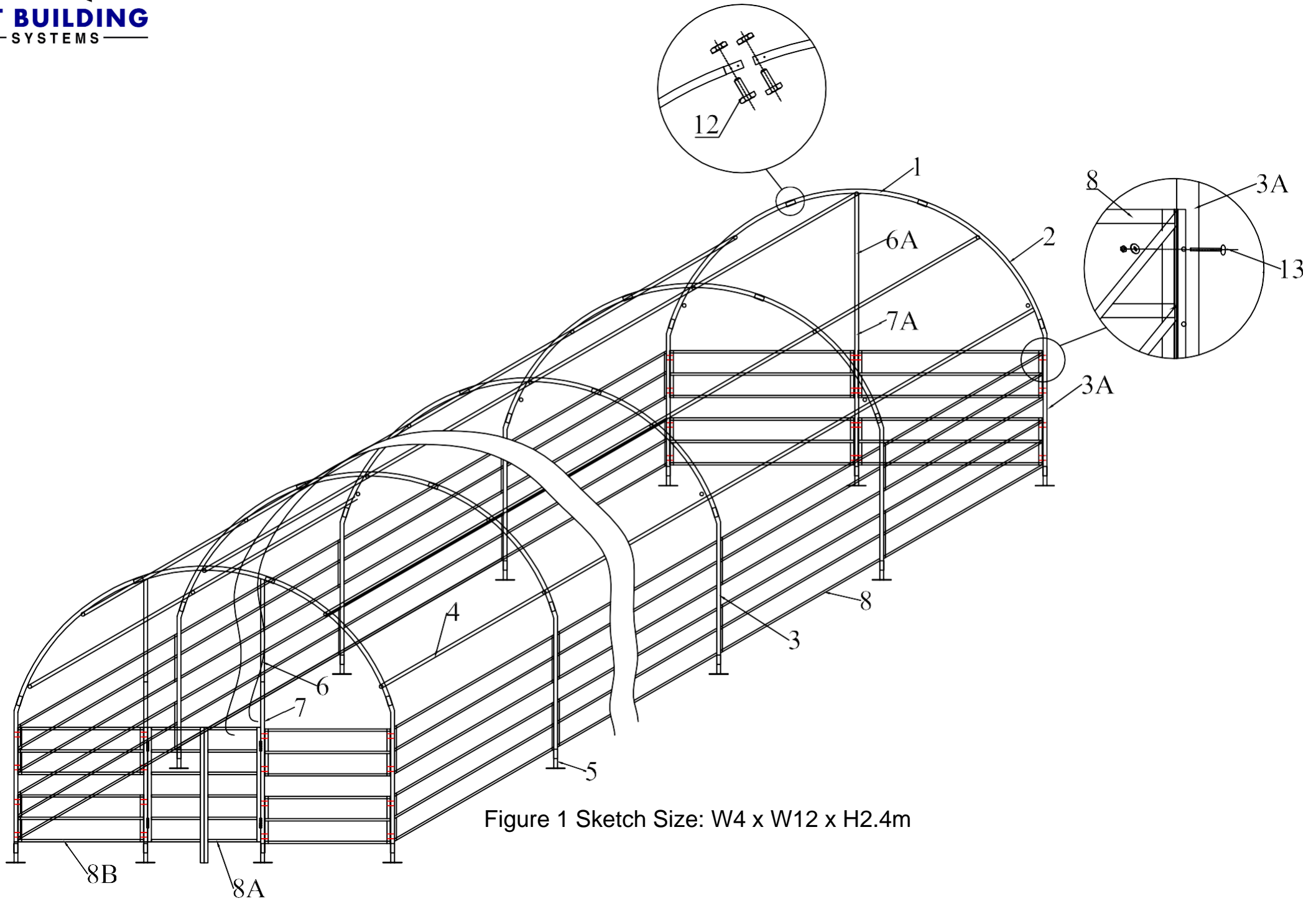

Figure 1 Sketch Size: W4 x W12 x H2.4m

Step #1 --SECURING BASE FLANGES

Sit the building boxes in the chosen location. Remove all the components from packaging to ensure all components are present by checking with the Part List.

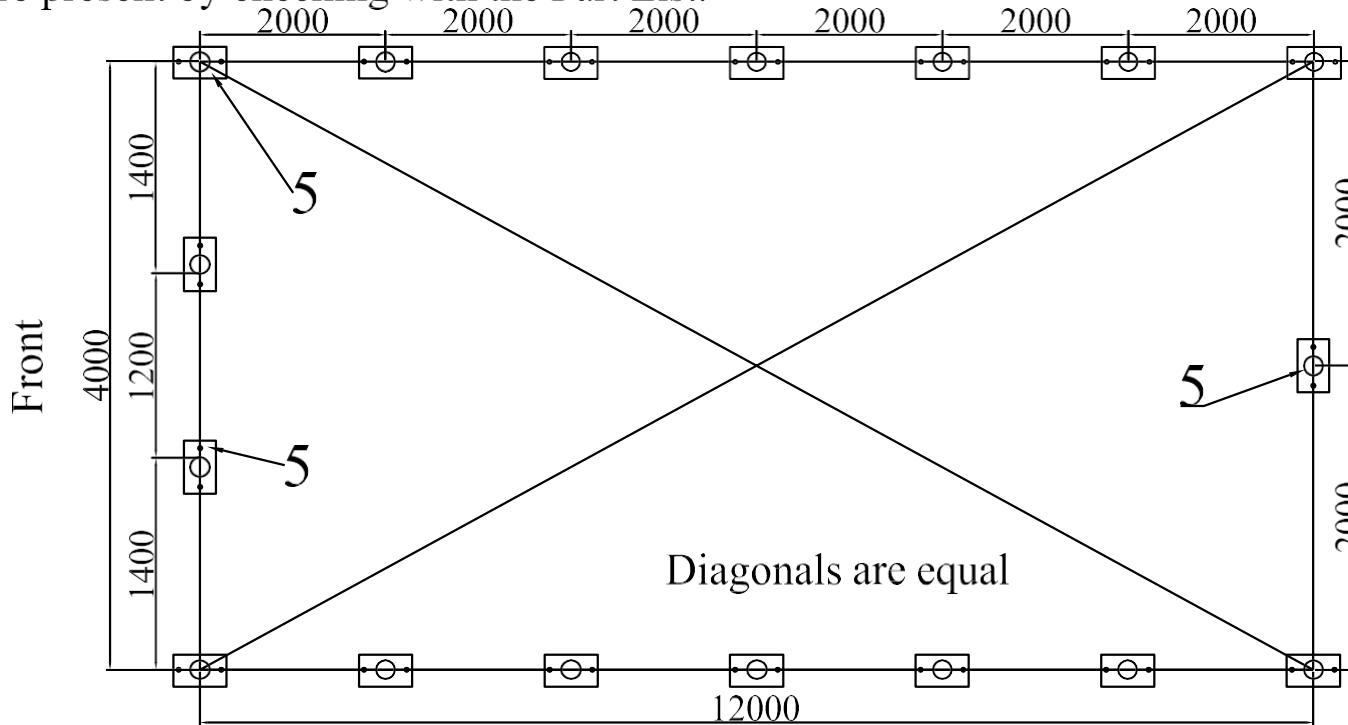

Figure 2 Position of Base Flanges

Begin by determining exact location of the four (4) corners of the building. Mark front edge and side-to-side width of assembly on ground. Drive alignment stakes into the ground outside of the markings, and draw alignment strings along both ends and sides of the building to the dimensions shown in Figure 2. The outline of the strings will represent the final location of the base flanges. The initial location of each Corner Base Flanges (5) is critical to the alignment and fit of the frame components and cover.

Locate the Left Corner Base Flange and Right Corner Base Flange (5). Secure the base flanges with Stake Pegs (Part #9). Measurements shown in Figure 2 are to the center of the upright sockets on each Base Flange.

The Shelter must be secured to a firm surface that can receive and retain augers and pegs firmly in position. The shelter should be installed on FIRM GROUND, not on SWAMP, SOFT/WET GROUND. The Base Flanges must be secured so they cannot be moved. Arches are tensioned at their base as they insert into the Base Plate sockets.

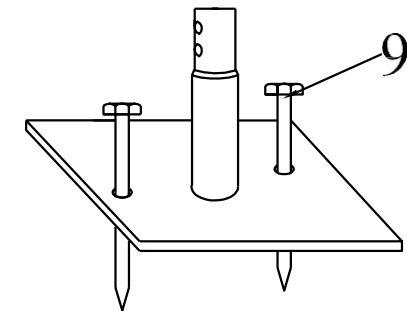

Figure 3

As Figure 3 shows, each base flange is equipped with two stake pegs.

Step #2 --ARCH ASSEMBLY

Assemble each arch on ground. Each arches consist of:

One curving roof tube (Part

#1) Two roof curving tube

(Part #2)

Two curving sidewall tube (Part # 3/3A)

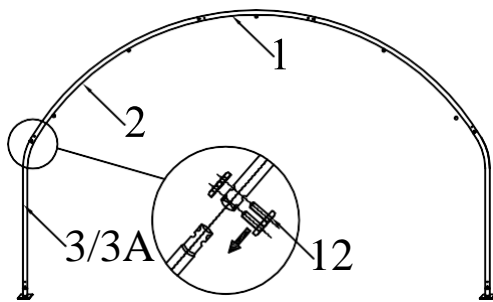

Figure 4 the arch installation

Connect the arches by Using the hexagon bolts with washers and nuts through predrilled holes in frame members. Do not tighten down the nuts completely until frame is fully assembled and set in place.

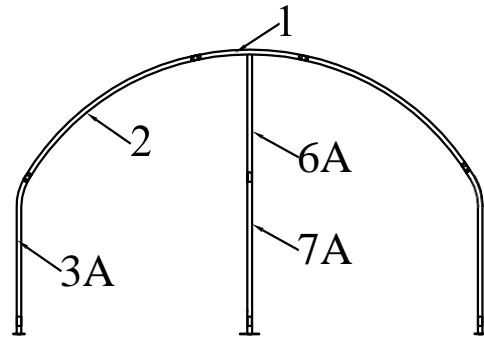

Figure 6
Frame Installation for Back Panel

Assemble the front panel frame. According to Figure 5&6, connect the end wall frame by Using the bolts with washers and nuts through predrilled holes in frame members. Do not tighten down the nuts completely until frame is fully assembled and set in place.

THE FRONT AND BACK PANEL FRAME ASSEMBLY

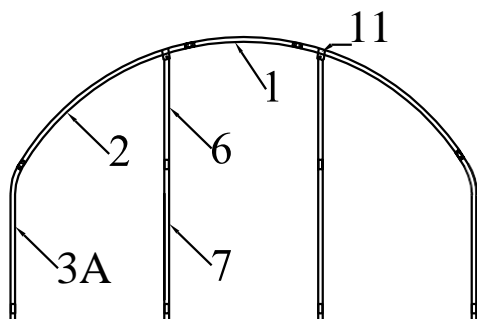

Figure 5
Frame Installation for Front Panel

NOTE: Please notice that the part code of the arch sections. The sections of different arches are not the same. Check with the Part List and the Sketch Figure #1.

Step #3 --ERECTING ARCHES

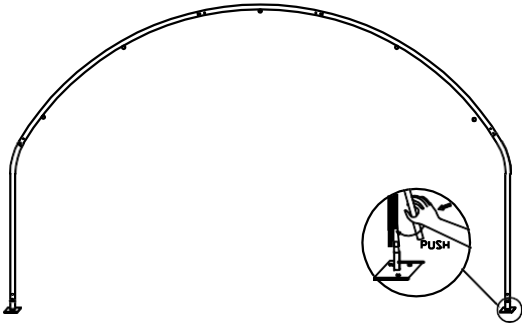

Figure 7
Attaching Arches to Base Flanges

Begin frame assembly by erecting Front Arch into Front Corner Base Flanges. Place left frame sidewall tubing into the upright tube socket into the Left Base Flange. Place Hexagonal Bolt through base flange socket and arch sidewall tube hole. In order to insert Right Sidewall Tube into Right Front Corner flange, it is necessary to support arch on left side to prevent movement. Position the Right Sidewall Tube over the Right Corner Base Flange. Once the Right Sidewall Tube is placed into right corner base flange, insert a hexagonal bolt and nut to prevent it from popping out of the socket while assembly continues. Next stand first interior arch up to repeat insertion into Base flanges.

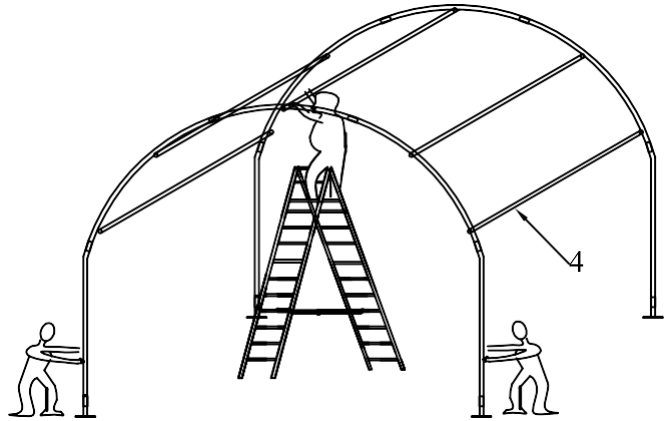
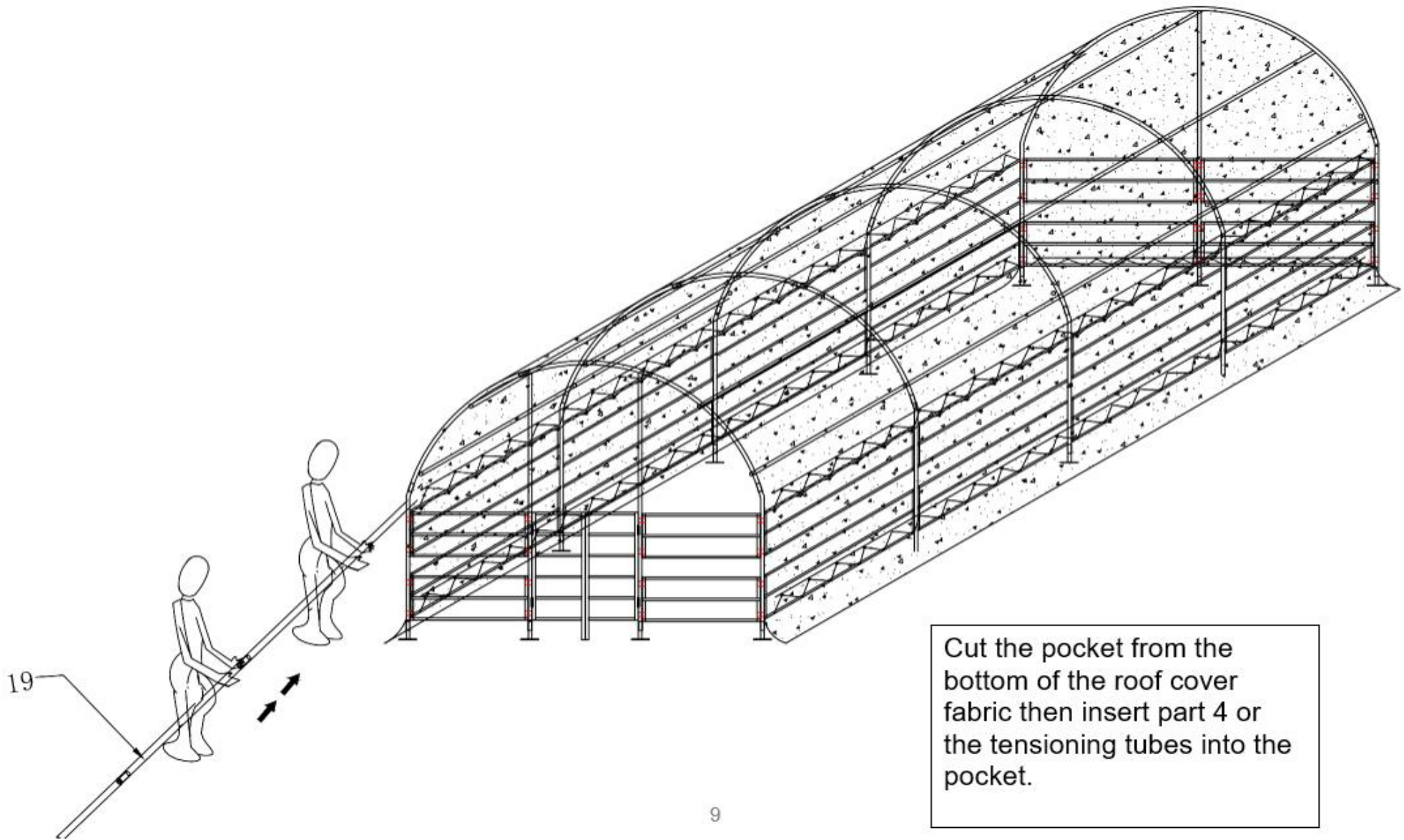

Figure 8

Immediately after putting first interior arch into place, connect Front Arch and Interior arch using Roof Purlin Tubes at top ridge and side shoulder curves of arches. Secure the Roof Purlin tubes into place using carriage bolts and nuts. Continue to install other Arches Assemblies in the same manner. Overlap pinched ends of Roof Purlin onto same carriage bolts inside frame assembly. Next check entire frame assembly for square and plumb. Next tighten frame bolts adequately. **DO NOT** over tighten bolts so as to oval or compress frame components.◦





Step #4--POSITION ROOF COVER

When ready to install the Roof Cover, unpack the cover and lay it parallel to the building frame on one side. The cover must be pulled over the top of the frame assembly without being snagged or stressed on any frame members. Use multiple ropes over top of the frame. Having another person inside the frame on a ladder to assist in getting the Roof Cover over the frame will ensure the cover will go on without any damage.

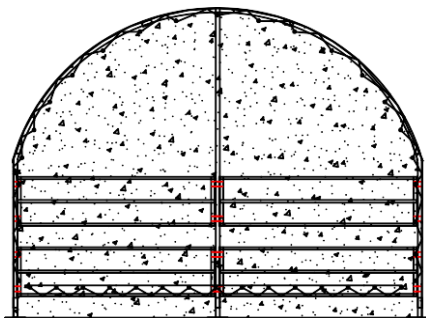
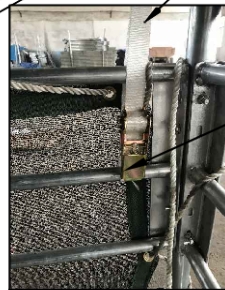
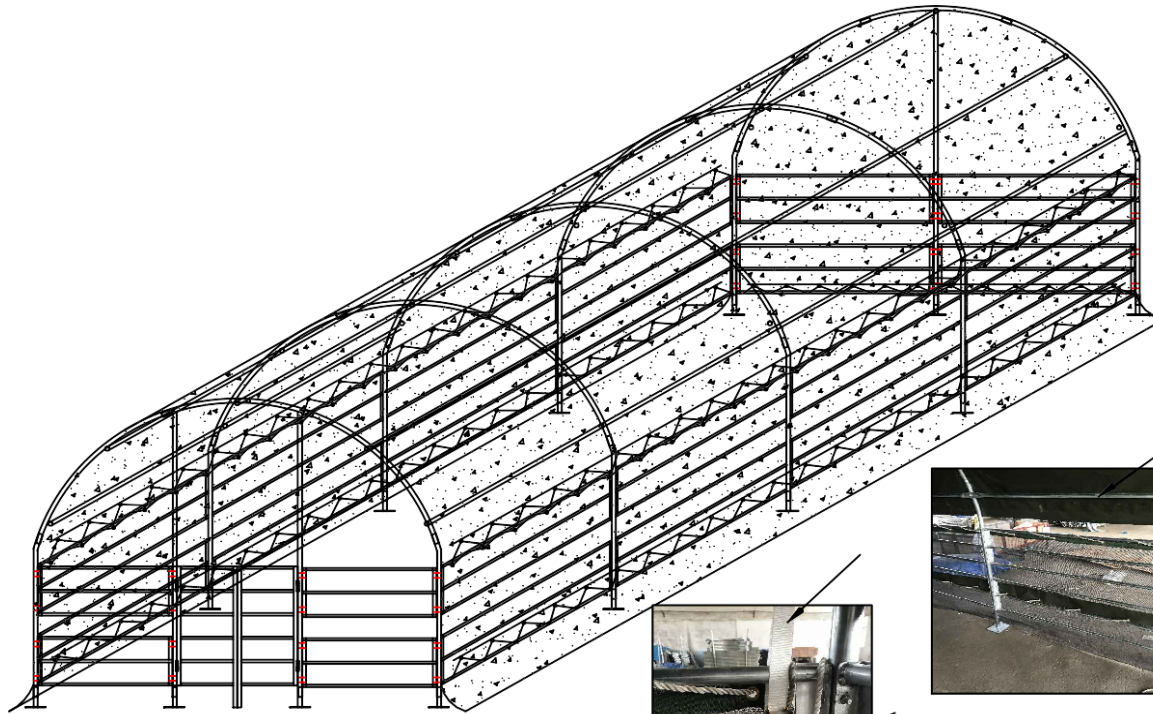



Figure 11



Figure 12



Figure 13



Figure 14