

VERSION HISTORY	NOTES
#	DATE
5.00	07-DEC-17
5.01	18-APR-18
5.1	17-NOV-23
	ORIGINAL
	UPDATED RUB STRIPS, CHANGED HINGE, CATCH BLOCK & HANDLE ASSEMBLY, LOWERED END 100MM CASTORS AND 23MM DEEPER

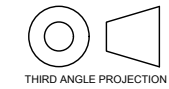

TITLE
48 X 30 TALL CADILLAC CASE

SHEET
PRODUCT SPEC SHEET

FIASCOCASES.COM

DATE
17-NOV-23

DESIGNED
ASH ALGIE

PROJECT MANAGER
JOE BRADFORD

SCALE | 1:10
PAPER | A4
FILE | 48 X 30 TALL CADILLAC CASE.VS
PLOT | 17/11/2023 11:41 AM
SHEET | 1 OF 1

VERSION

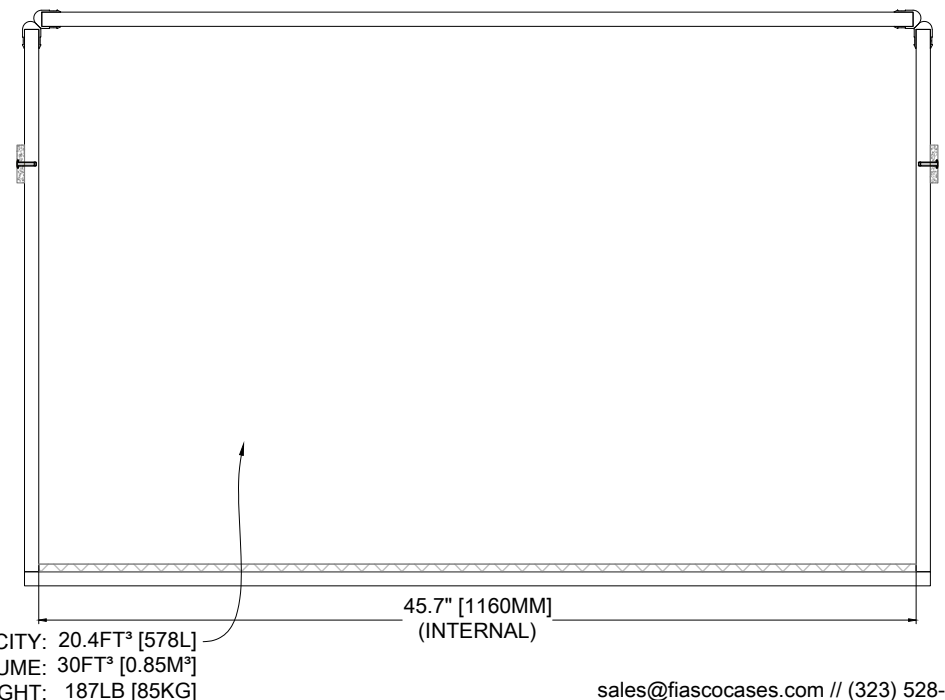
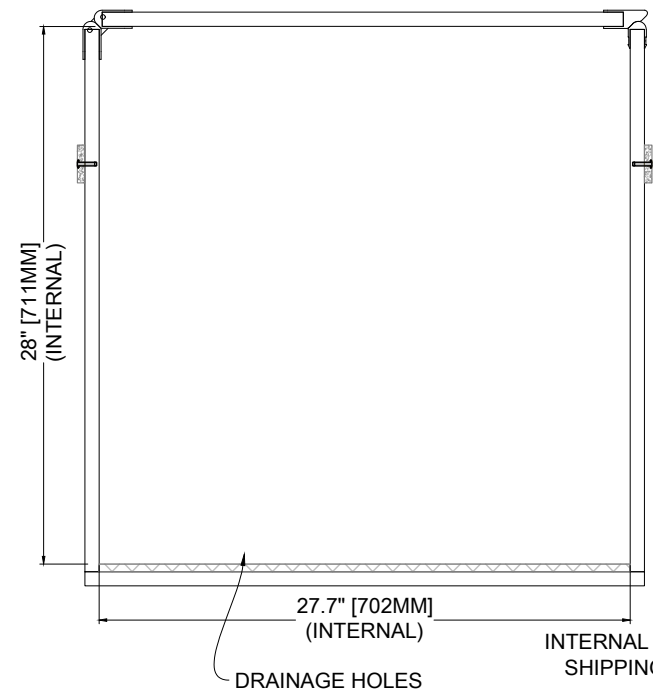
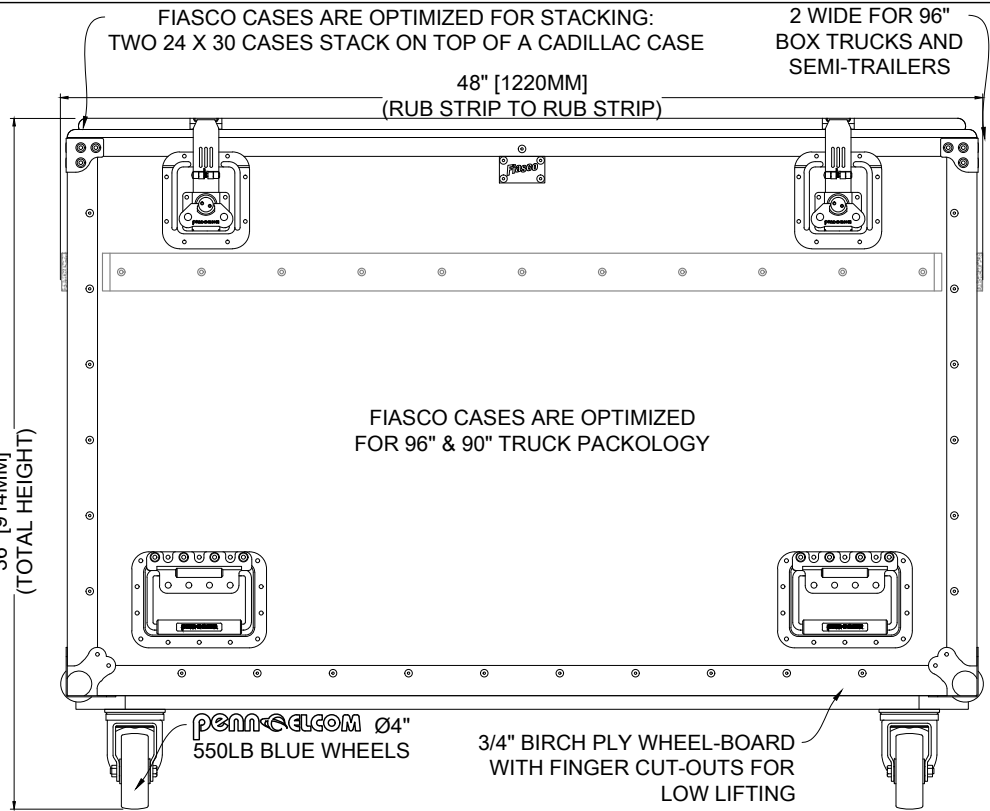
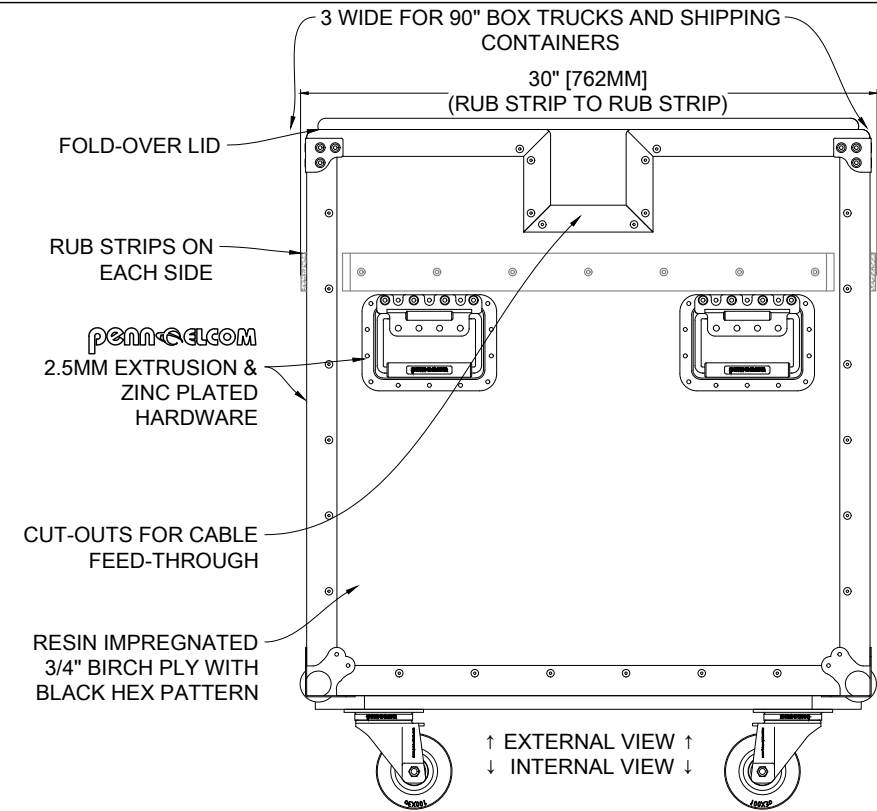

INTERNAL CAPACITY: 20.4FT³ [578L]
SHIPPING VOLUME: 30FT³ [0.85M³]
WEIGHT: 187LB [85KG]