

Gas Pizza Oven Box

Wood fired performance at home

Product Guide

Model # O-AJKXX-O-000

Important, Retain for Future Reference: Read Carefully

Note to Installer: Product Guide must be left with the consumer.

WARNING: This product guide contains important information necessary for the proper assembly and safe use of the appliance.

Read and follow all warnings and instructions before assembling and using the appliance.

Follow all leak-check procedures in the Product Guide before using the appliance.

This appliance is for outdoor use only.



DANGER

If you smell gas:

- 1. Shut off gas to the appliance.**
- 2. Extinguish any open flame.**
- 3. If odor continues, keep away from appliance and immediately call your gas supplier or your fire department.**

Failure to follow these instructions could result in fire or explosion which could cause property damage, personal injury or death.



WARNING

- 1. Do not store or use gasoline or other flammable liquids or vapors in the vicinity of this or any other appliance.**
- 2. An LP cylinder not connected for use shall not be stored in the vicinity of this or any other appliance.**

BakerStone

www.bakerstonebox.com - (855) 657 OVEN (6836)
3617 W. MacArthur Blvd, Unit 500
Santa Ana, California, USA 92704

WARNINGS

Failure to follow these instructions could result in fire or explosion which could cause property damage, personal injury or death.

The installation must conform with local codes or, in the absence of local codes, with either the *National Fuel Gas Code*, ANSI Z223.1/NFPA 54, or the *Natural Gas and Propane Installation Code*, CSA B149.1, or the *Propane Storage and Handling Code*, CSA B149.2, or the *Standard for Recreational Vehicles*, ANSI A119.2/NFPA 1192, and CSA Z240 RV Series, *Recreational Vehicle Code*, as applicable.

This appliance shall be used only outdoors, and shall not be used inside a building, garage or any other enclosed area.

This appliance is not intended to be used in or on a recreational vehicle or boat.

While using this appliance maintain a minimum clearance from sides and back of at least 10 feet (3M) between appliance and any combustible material or construction. Do not use this appliance under overhead combustible surfaces.

Clean and inspect the supply hose and regulator before each use of the appliance. If there is evidence of abrasion, wear, cuts, or leaks, the hose must be replaced prior to using the appliance. Only the included hose or a replacement supplied by the manufacturer shall be used with the appliance.

The appliance is only to be fueled by a LP (liquid propane) gas cylinder measuring 12" (30.5cm) diameter and 18" (45.7cm) high with a 20lb. (9.1kg) capacity. The gas cylinder (tank) must incorporate a Type 1 cylinder valve and an over filling protection device (OPD).

The LP gas cylinder must be constructed and marked in accordance with the Specifications for LP gas Cylinders of the U.S. Department of Transportation (D.O.T.) or the Standard for Cylinders, Spheres and Tubes for Transportation of Dangerous Goods and Commission, CAN/CSA-B339, as applicable.

Do not unhook or replace the LP Gas Cylinder while the appliance is in use.

Before each use and after replacing the LP gas cylinder perform a leak check at all connections and fittings. Do not use an open flame to check for leaks.

Keep the fuel supply hose away from any heated surface(s).

This appliance is not intended for commercial use.

The use of alcohol, prescription or non-prescription drugs may impair the consumer's ability to properly assemble or safely operate the appliance.

In the event of an oil or grease fire do not attempt to extinguish with water. Immediately call the fire department. A Type BC or ABC fire extinguisher may, in some circumstances contain and/or extinguish the fire.

Do not leave the appliance unattended. Keep children and pets away from the appliance at all times.

Do not move the appliance when in use.

WARNINGS – continued

This appliance is not intended for and should never be used as a heater.

This appliance will be hot during and after use. Use insulated oven mitts or gloves for protection from hot surfaces or splatter from cooking liquids.

Do not touch the appliance until it has completely cooled. The black metal housing can reach temperatures of 400°F(200°C) +/- during use.

Use only appropriate bake-ware or utensils while baking and cleaning the appliance. Do not use plastic, silicone or glass.

Do not allow food other than Pizza or Bread Dough to contact the stones. Any foods that contain fat, oil or butter (meats, items coated with olive oil, cookies, biscuits, etc.) should not contact the stones directly. These items should be baked in a metal baking pan, on a metal baking sheet or in a cast-iron skillet as the stones will absorb the fat, oil and butter which can cause smoking, odors, staining, and can impart rancid flavors to items that you bake in the future.

Stones are fragile and can break if dropped. The appliance becomes extremely hot, do not touch the stones or any other part of the appliance while it is in use.

To clean stones, heat the appliance for 15 minutes after food is cooked and scrape off any remaining residue. Do not use any cleaning agents or other liquids to clean the stones.

Do not place gasoline, alcohol, wood products, charcoal or any other combustible material (unless BakerStone approved) in the baking chamber.

Remove any appliance cover and place at least 10 feet (3 Meters) from appliance before use.

Do not alter or change the gas valve orifices.

This appliance requires regular cleaning of major components and more detailed cleaning of burner system after prolonged period of storage. Insects and/or insect nests may prevent safe usage and proper performance of the appliance.

Only use the pressure regulator and hose included with this appliance.

Do not alter or install as a built in appliance.

The use of alcohol, prescription, or non-prescription drugs may impair the consumer's ability to properly assemble or safely operate the appliance.



Master Contract: 219529

Table of Contents	Page
What's in the package	4
Assembly of the Pizza Oven Box	5
Assembly of the Cart	8
LP Gas Cylinder Requirements	11
LP Gas Cylinder Placement	12
LP Gas Cylinder Connection	13
LP Gas Leak Test	14
Pre-Use Safety Checks	14
Lighting Instructions	15
How to Use	16
Routine Care & Cleaning	18
Periodic Care & Cleaning of Burner System	19
Customer Service	20
Warranty	21
Frequently Asked Questions	23

What's in the package

Before assembling your Pizza Oven Box, ensure that all parts below are included.

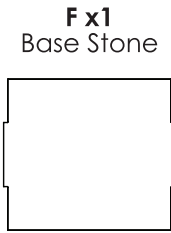
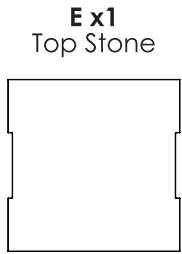
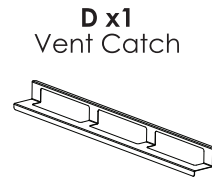
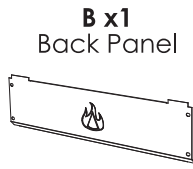
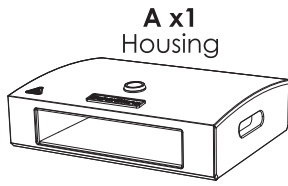

Tab
Notch

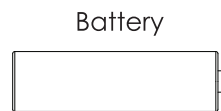
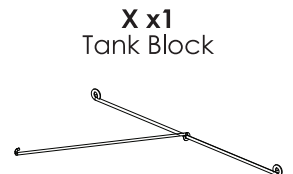
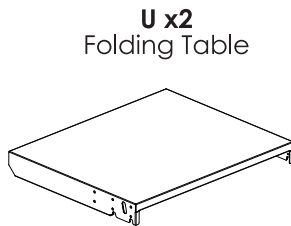
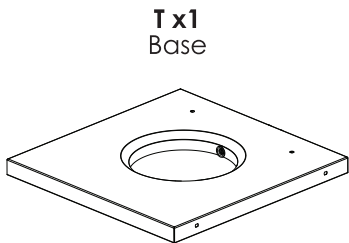
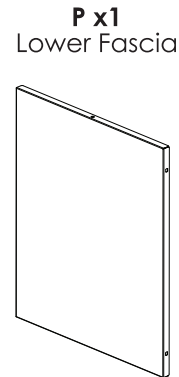
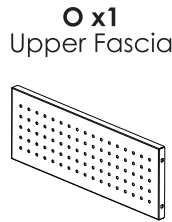
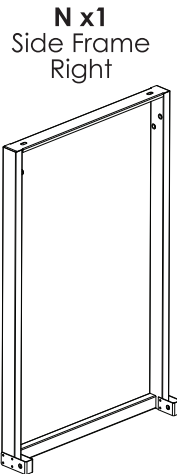
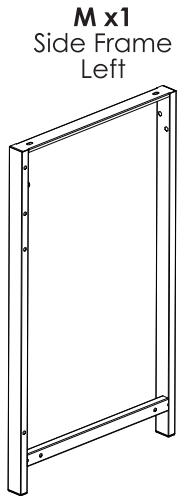
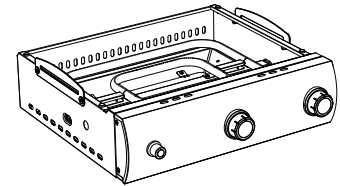
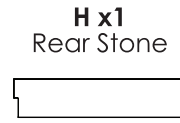
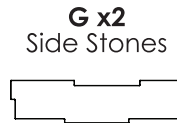

Tools required for assembly, not included:

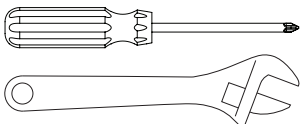

Have a question? Please Do Not Return This Product To The Store.
Contact us first! 1-855-657-6836 or email support@bakerstonebox.com

Assembly of the Pizza Oven Box

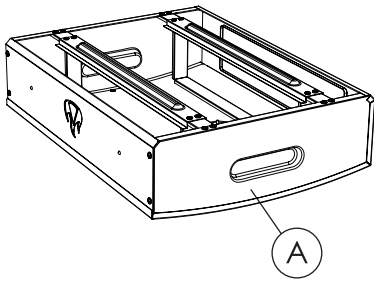

STEP 1. Place the HOUSING (A) carefully upside down on a clean, soft surface. **NOTE:** Failure to do so may result in scratching or denting the Pizza Oven Box.

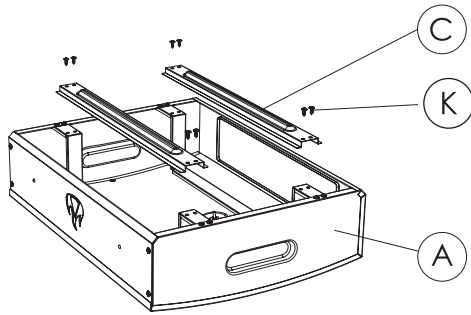

STEP 2. Remove the STONE SUPPORTS (C) from the HOUSING (A) by removing 8 SCREWS (K).

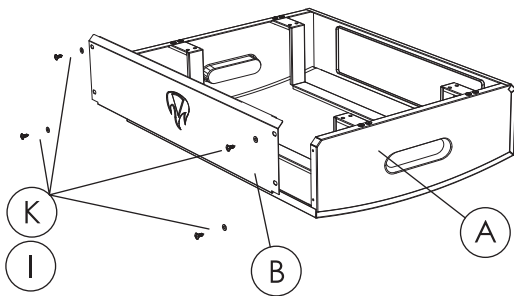

STEP 3. Remove the BACK PANEL (B) from the HOUSING (A) by removing its 4 SCREWS (K) and 4 FLAT WASHERS (I). You will identify the BACK PANEL (B) by the embossed BakerStone flame logo on this panel.

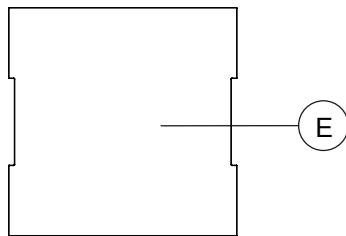

STEP 4. Identify the TOP STONE (E), this is the largest stone in the box. **NOTE:** There are notches on both sides of this stone.

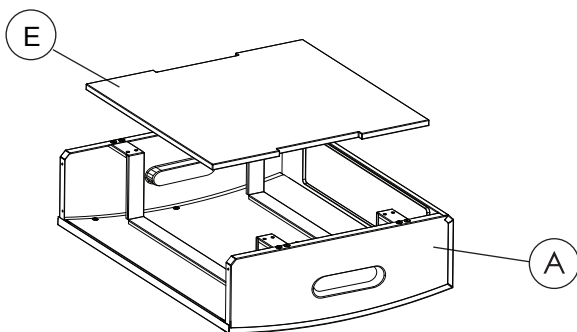

STEP 5. Gently fit the TOP STONE (E) into the Stone Cradles of the HOUSING (A).

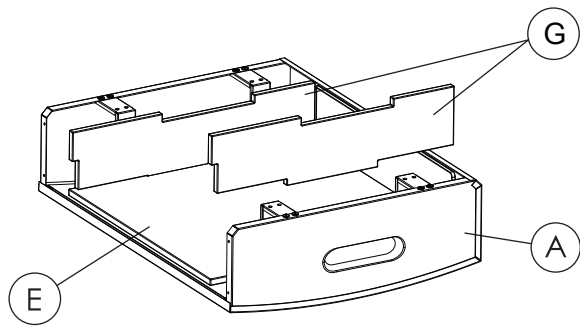

STEP 6. Identify the 2 SIDE STONES (G). Fit the 2 SIDE STONES into the notches of the TOP STONE (E). **NOTE:** The flat end of the SIDE STONES (G) should face the front of the oven.

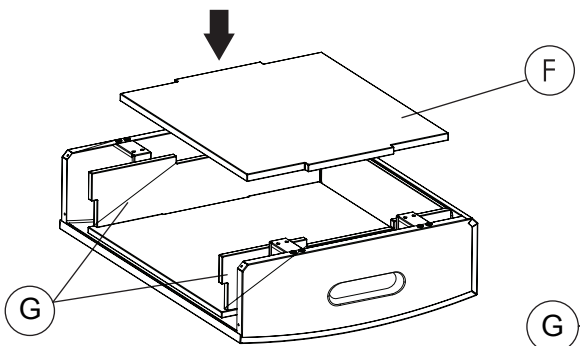

STEP 7. The other large stone is the BASE STONE (F). Fit this in between and on top of the 2 SIDE STONES (G).

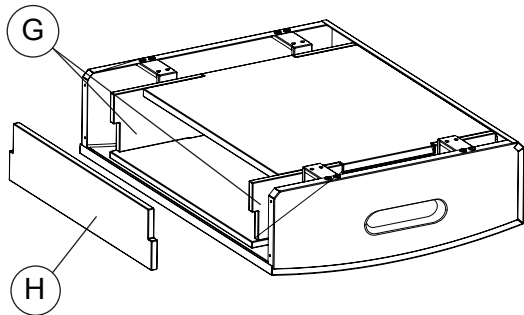
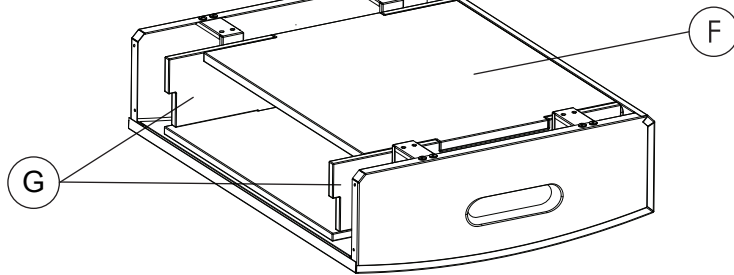

STEP 8. Fit the remaining REAR STONE (H) into the notches of the 2 SIDE STONES (G).

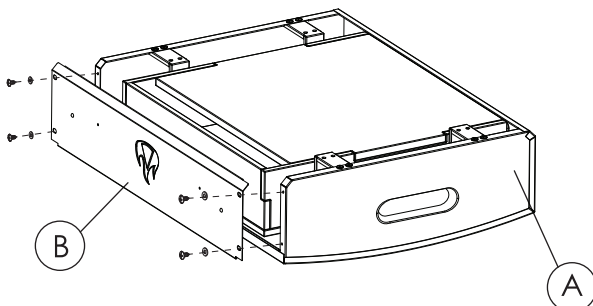

STEP 9. Place the BACK PANEL (B) back onto the HOUSING (A) and secure with 4 SELF TAPPING SCREWS (K) and 4 FLAT WASHERS (I). **NOTICE: Do not over tighten screws, cracking of the enamel finish may occur.**

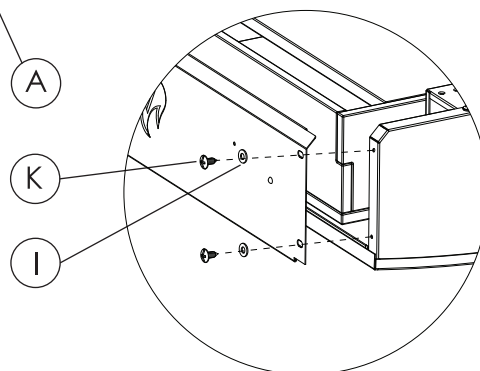

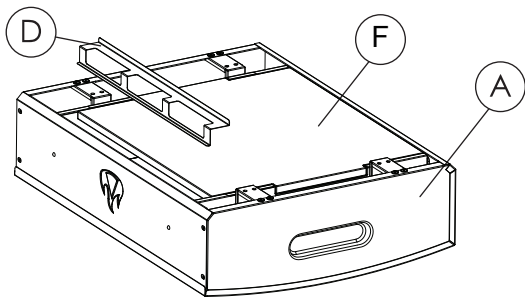

STEP 10. Locate the VENT CATCH (D) and place into the vent of the oven and resting on the BASE STONE (F).

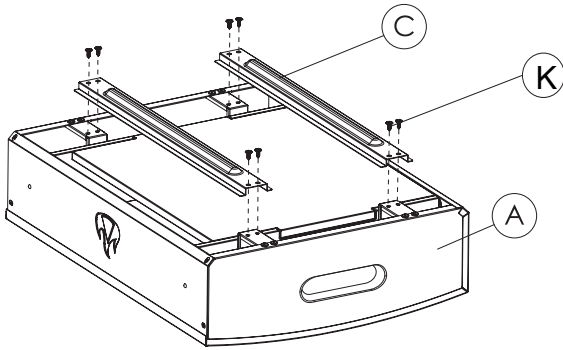

STEP 11. Place the STONE SUPPORTS (C) across the HOUSING (A) and secure with SELF TAPPING SCREWS (K). Ensure the upper lip of the VENT CATCH (D) sits inside the rearmost STONE SUPPORT (C).

NOTE: The flat side of the STONE SUPPORTS (C) faces toward the stones and the protruding ridge faces up.

NOTICE: Do not over tighten screws, breakage of stones may occur.

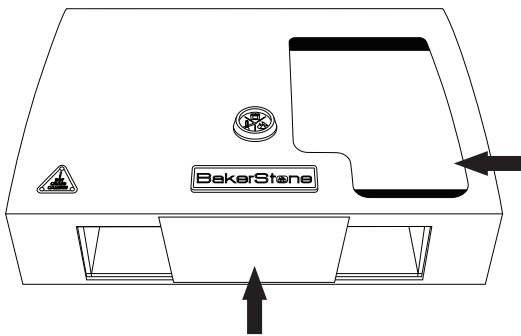
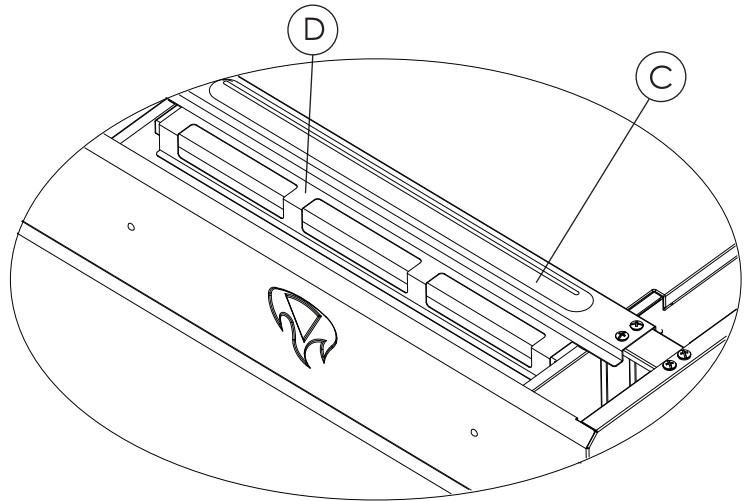
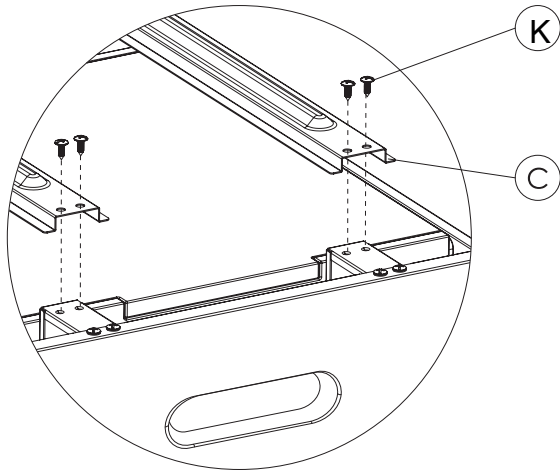

STEP 12. Turn the Pizza Oven Box over. **NOTICE:** Remove all stickers before placing on Firebox.

NOTE: Before using your Pizza Oven Box for the first time, wipe the base stone with a damp cloth to remove any packaging debris.

Assembly of the Cart

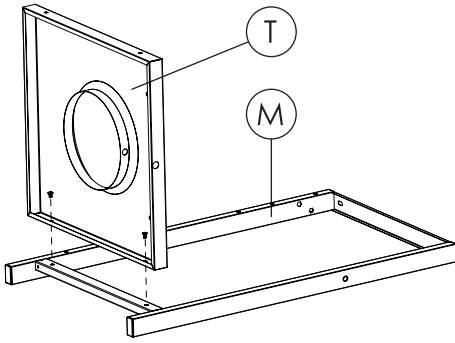

STEP 1. Identify the LEFT SIDE FRAME (M) and BASE (T). Attach the BASE to the LEFT SIDE FRAME using 2 M6 SCREWS (W).

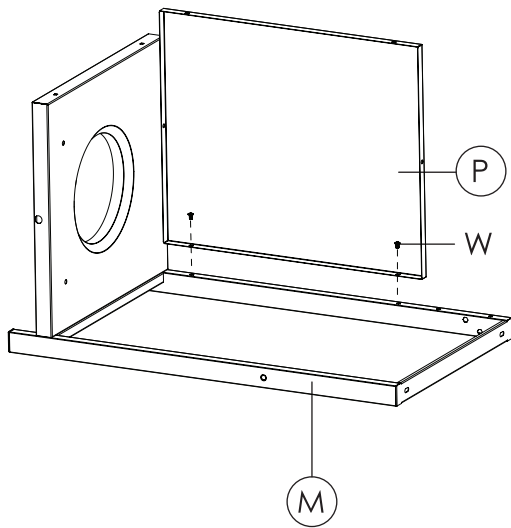
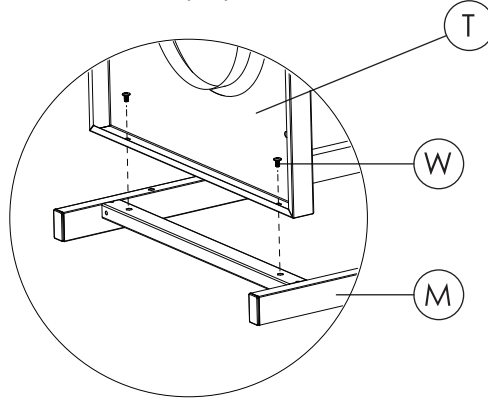

STEP 2. Identify the LOWER FASCIA (P). Attach the LOWER FASCIA to the LEFT SIDE FRAME using 2 M6 SCREWS (W).

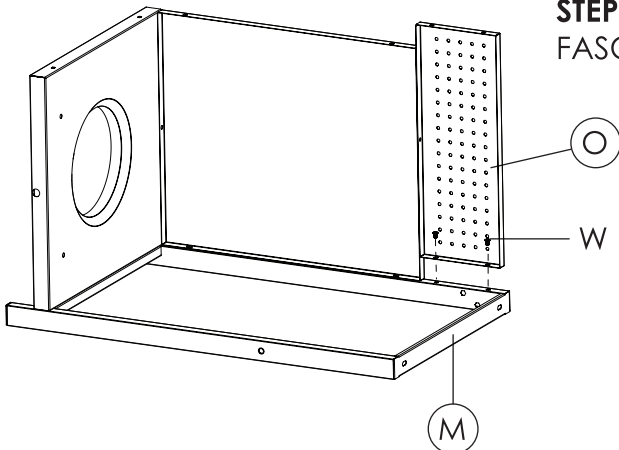
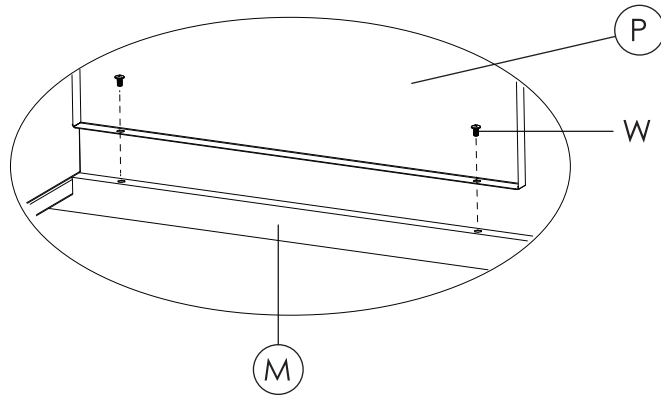

STEP 3. Identify the UPPER FASCIA (O). Attach the UPPER FASCIA to the LEFT SIDE FRAME using 2 M6 SCREWS (W).

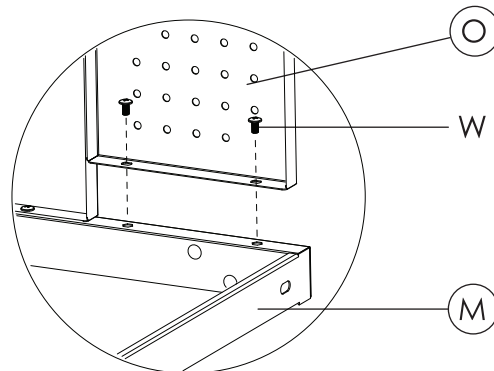

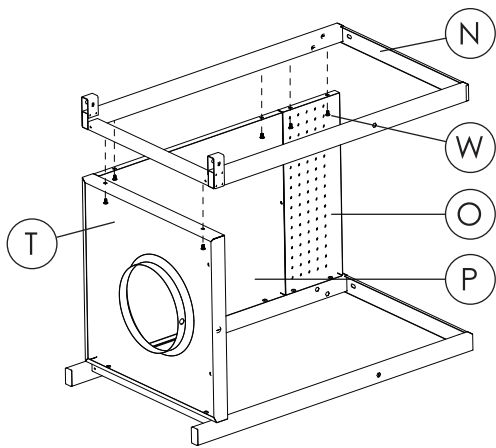

STEP 4. Identify the RIGHT SIDE FRAME (N). Attach the RIGHT SIDE FRAME to the BASE, UPPER FASCIA AND LOWER FASCIA using 6 M6 SCREWS (W).

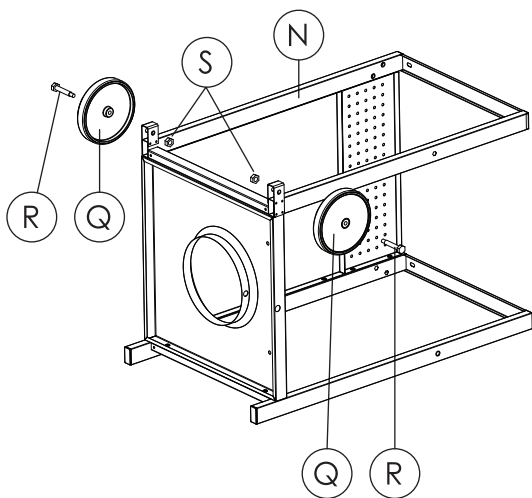
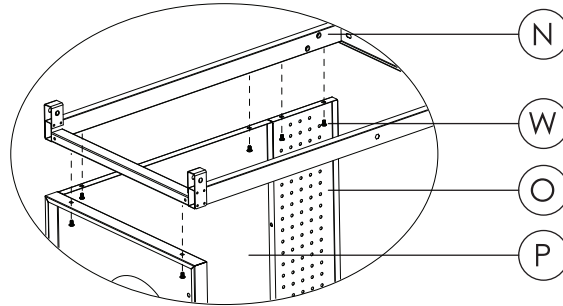

STEP 5. Identify the 2 WHEELS (Q), WHEEL BOLTS (R) and HEX NUTS (S). Attach the WHEELS to the RIGHT SIDE FRAME using the WHEEL BOLTS and HEX NUTS as shown below.

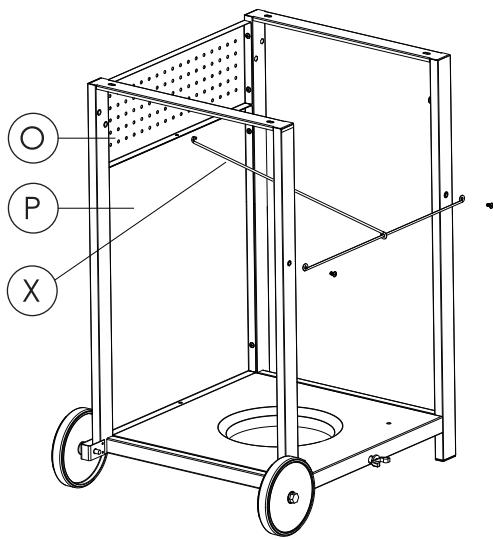
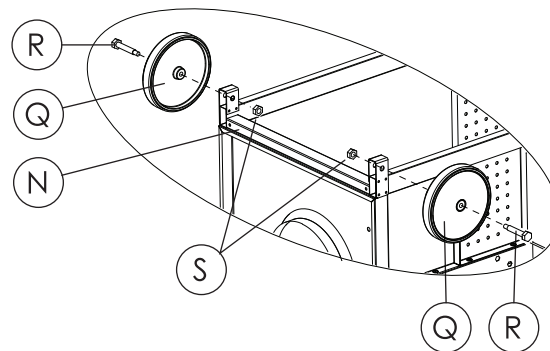

STEP 6. Identify the TANK BLOCK (X) and insert the open end through the hole between the UPPER FASCIA (O) and LOWER FASCIA (P). Then attached to the RIGHT SIDE FRAME and LEFT SIDE FRAME using M6 SCREWS (W).

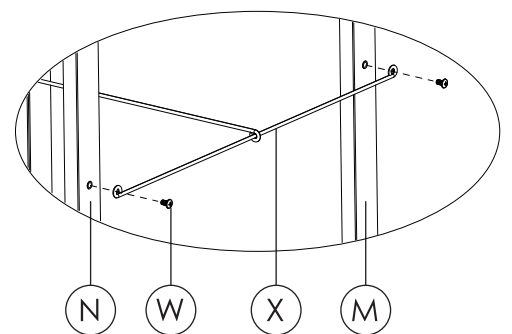
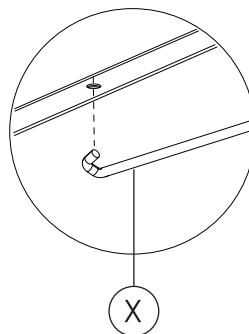

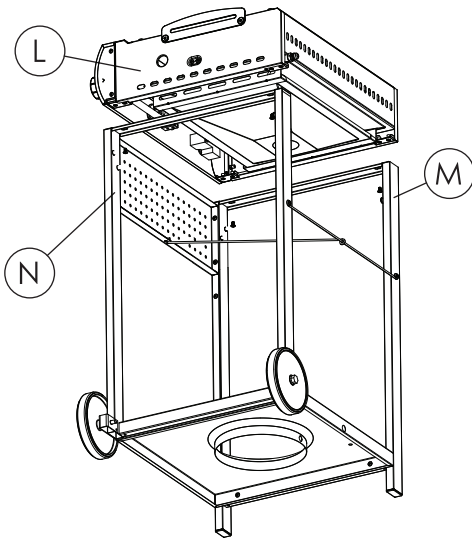

STEP 7. Identify the FIREBOX (L). Attach the FIREBOX to the LEFT SIDE FRAME and RIGHT SIDE FRAME using 4 M6 SCREWS (W).

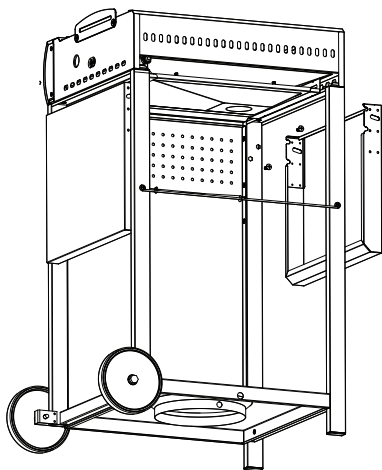
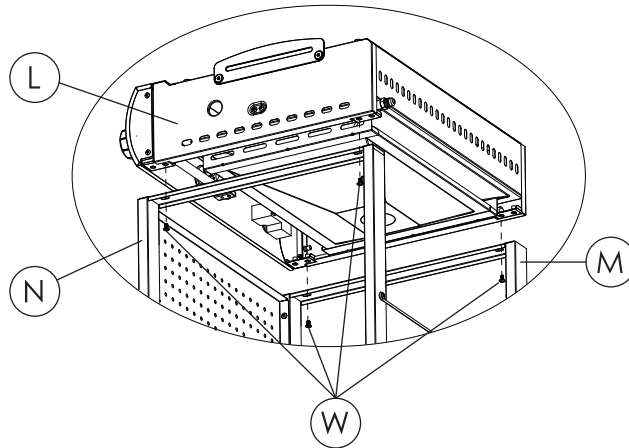

STEP 8. Identify the 2 SIDE TABLES (U). Attach the SIDE TABLES to the LEFT SIDE FRAME and RIGHT SIDE FRAME using SHOULDER SCREWS (V). Each SIDE TABLE requires 4 SHOULDER SCREWS.

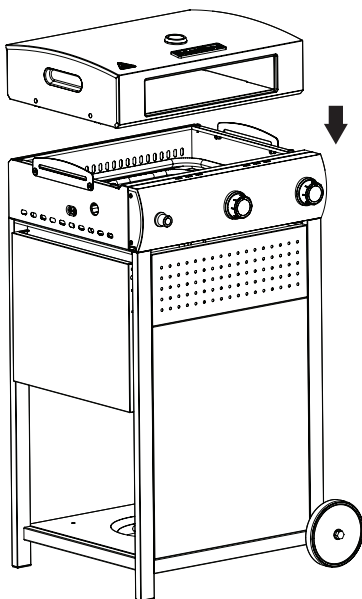
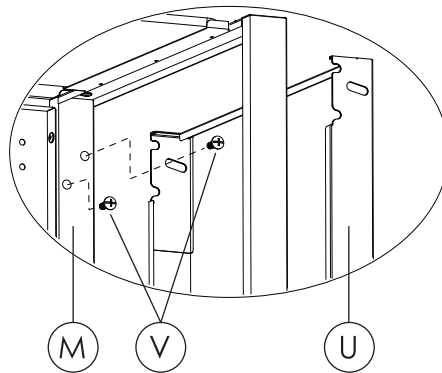

STEP 9. Place the Pizza Oven Box onto the assembled FIREBOX and CART. **NOTE:** Prior to first use wipe all surfaces with a damp cloth.

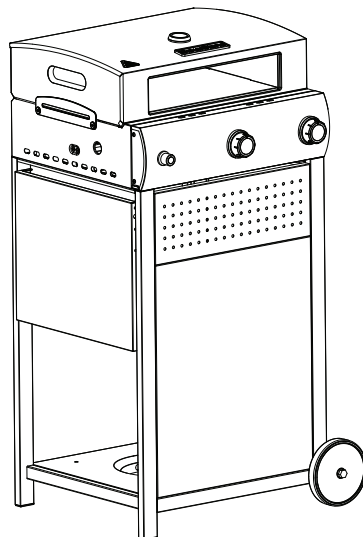

LP Gas Cylinder (tank) Requirements

The appliance is only to be fueled by an LP (liquid propane) gas cylinder measuring 12" (30.5cm) diameter and 18" (45.7cm) high with a 20lb. (9.1kg) capacity. The gas cylinder (tank) must incorporate a Type 1 cylinder valve and an over filling protection device (OPD).

The LP gas cylinder must be constructed and marked in accordance with the Specifications for LP gas Cylinders of the U.S. Department of Transportation (D.O.T.) or the Standard for Cylinders, Spheres and Tubes for Transportation of Dangerous Goods and Commission, CAN/CSA-B339, as applicable.

Place dust cap on cylinder valve outlet whenever the cylinder is not in use. Only install the type of dust cap on the cylinder valve outlet that is provided with the cylinder valve. Other types of caps or plugs may result in leakage of propane.

The gas cylinder must have:

- A shutoff valve terminating in a Type 1 gas cylinder valve outlet.
- A Type 1 valve that prevents gas flow until a positive seal is obtained.
- An arrangement for vapor withdrawal. The gas cylinder must be kept in the upright position at all times.
- A collar to protect the shut-off valve.
- A safety relief device that has direct communication with the vapor space of the gas cylinder.
- A listed over filling prevention device (OPD).

This appliance is not intended to be used with natural gas.

Appliance Installation Requirements

This appliance must be installed in accordance to the following codes:

- National Fuel Gas Code ANSI Z223.1 NFPA 54
- Natural Gas and Propane Installation Code: CAN/CGA B149.1
- Natural Gas Installation Code: CAN/CGA B149.1 (Canada)
- Propane Installation Code: CAN/CGA B149.2 (Canada)

LP Gas Cylinder (tank) Filling Requirements:

- LP gas cylinder should only be filled by a qualified licensed LP gas dealer.
- New LP gas cylinders must be purged prior to filling.
- DO NOT allow the cylinder to be filled beyond 80% capacity. Over-filled LP gas cylinders can create a dangerous condition. Over-filled LP gas cylinders can build-up pressure and cause the relief valve to expel propane gas vapors. The vapor is combustible and if it comes in contact with a spark source or flame an explosion causing severe burns, bodily harm, or death could occur.
- Always use a protective cylinder cap when grill is not connected to the gas cylinder.
- Inspect the LP gas cylinder valve rubber seal for cracks, wear or deterioration prior to use. A damaged rubber seal can cause a gas leak, possibly resulting in an explosion, fire or severe bodily harm.

Spare LP Gas Cylinder

- Do not store a spare LP gas cylinder under or near the appliance.

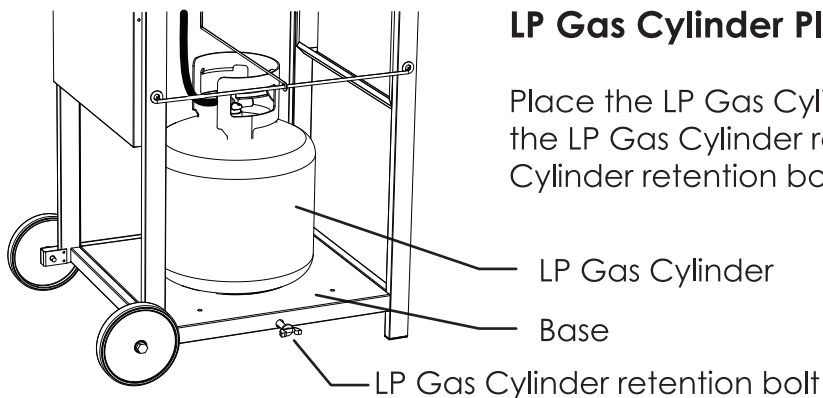

LP Gas Cylinder Placement

Place the LP Gas Cylinder into the Base and secure with the LP Gas Cylinder retention bolt. Turn the LP Gas Cylinder retention bolt clockwise to tighten.

WARNING:

The pressure regulator and hose assembly supplied with the appliance must be used. Replacement pressure regulators and hose assemblies shall be those specified by the appliance manufacturer.

Storage of this appliance indoors is permissible only if the cylinder is disconnected and removed from the appliance.

Cylinders must be stored outdoors out of the reach of children and shall not be stored in a building, garage, or any other enclosed area.

Only use this appliance outdoors in a well ventilated area.

Never operate this appliance within 10 ft (3.0 m) of any structure, combustible material or other gas cylinder.

Do not use this appliance under overhead combustible construction.

Do not place or use this appliance on a combustible surface.

This appliance becomes hot, do not place on any surface which cannot withstand high temperatures without deforming or being damaged.

This appliance is not to be installed in or on boats or recreational vehicles.

Failure to follow these instructions could result in fire, explosion or burn hazard which could cause property damage, personal injury or death.

Battery Installation

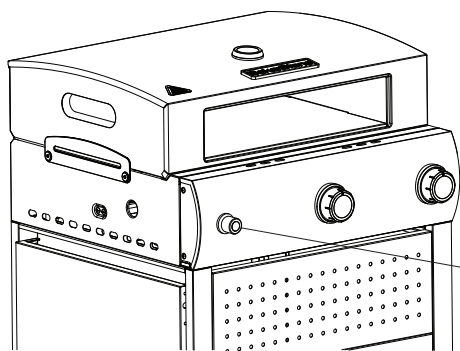

STEP 1. Unthread the Ignitor Button and insert the included Battery into the ignitor. Reinstall the button by threading it back into place.

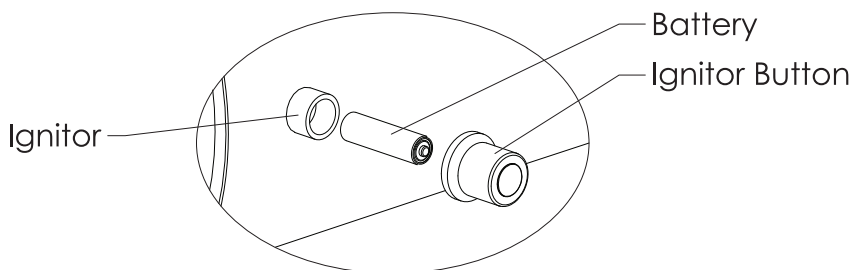

LP gas cylinder connection:

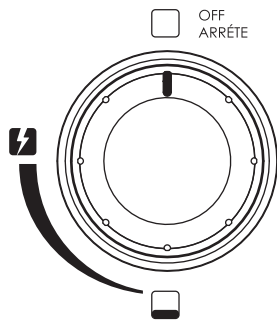

Figure - 1
Burner Control Knob

Step 1 Ensure the LP cylinder used conforms to the requirements listed on the previous page. Also inspect the LP gas cylinder valve rubber seal for deterioration such as cracks, deformation or tears.

Step 2 Inspect the LP gas cylinder valve to ensure the threads match that of the included hose and regulator.

Step 3 Ensure all the burner control knobs are in the OFF position. See Figure - 1, Burner Control Knob.

Step 4 Thread the included hose and regulator onto the LP gas cylinder. Turn the coupling fastener clockwise by hand until it stops. **WARNING: Do not use tools to tighten the coupling fastener.**

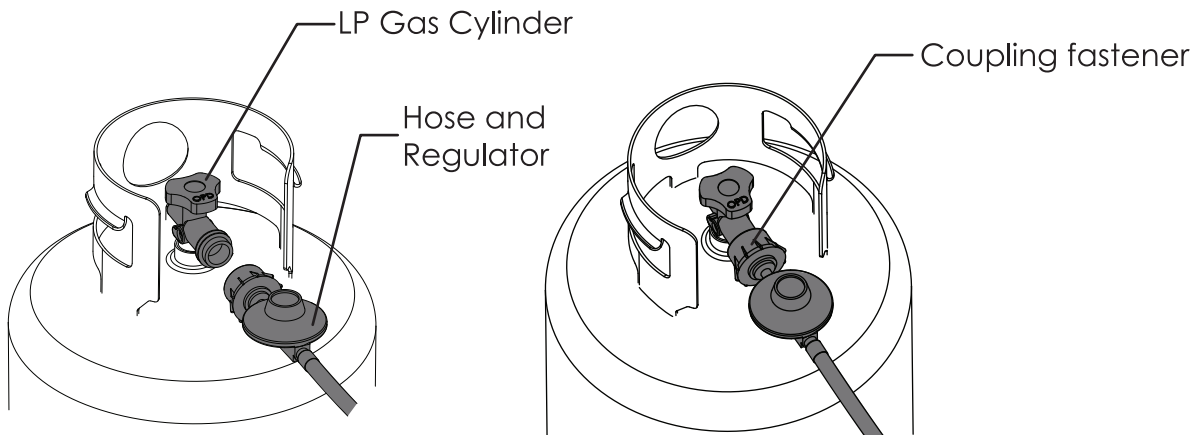

Figure - 2
Hose and regulator attachment

LP Gas Cylinder Valve

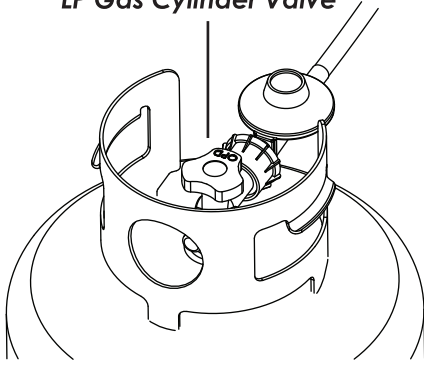

Figure - 3

LP Gas Leak Test

Before first use and after each time the LP gas cylinder is reconnected or changed the LP gas Leak Test must be performed.

Do not use an open flame to check for leaks.

Do not smoke or be in the presence of any ignition sources while performing a leak test.

Perform leak test outdoors in a well ventilated area.

Step 1 Prepare a soapy water solution of water and detergent.

Step 2 After connecting the appliance to the LP gas cylinder, slowly open the valve completely [see Figure - 3].

Step 3 Listen for any hissing sounds. **WARNING: If hissing sounds are present turn off the gas valve and contact a licensed gas repair specialist.**

Step 4 Spray a mild soapy water solution on all gas connections. Inspect all connections for the growing presence of bubbles [see Figure - 4]. These bubbles represent a leak. If a leak is present tighten the fitting and test again with the soapy water solution. **WARNING: If bubbles remain present turn off the gas valve and contact a licensed gas repair specialist.**

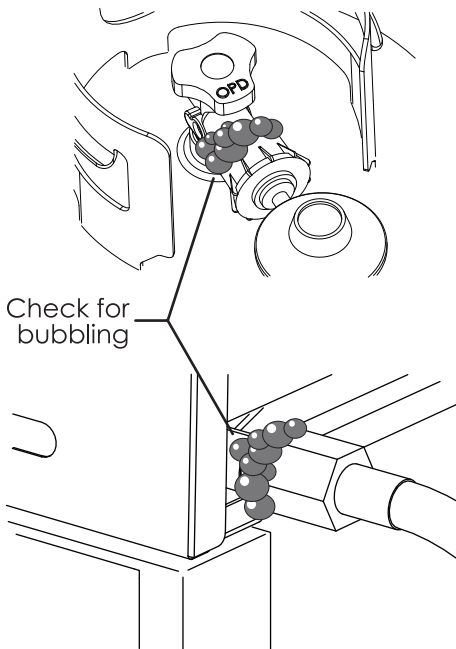

Figure - 4

Pre-Use Safety Check

Before first use and after each time the LP gas cylinder is reconnected or changed the LP gas Leak Test must be performed.

Check all components for proper assembly and function.

Place the appliance outdoors on a secure, stable, non-combustible, and level surface.

Ensure this appliance is at least 10 ft (3.0 m) from any structure, combustible material or other gas cylinder.

Ensure all surfaces including firebox and grease tray are clean prior to each use of the Pizza Oven Box.

WARNING: Failure to follow these instructions could result in fire, explosion or burn hazard which could cause property damage, personal injury or death.

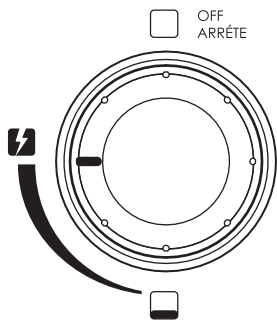

Figure - 7
Burner Control Knob

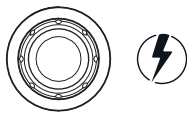

Figure - 8
Ignition Button

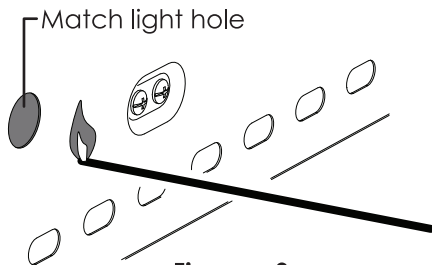

Figure - 9

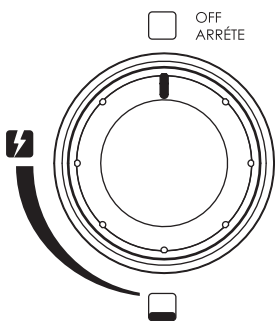



Figure - 10

WARNING: Read and follow all instructions and warnings listed on prior pages before attempting to use the appliance.

LIGHTING INSTRUCTIONS



Step 1 Turn on the gas tank valve.

Step 2 Push and turn one of the burners to  (HIGH) [see Figure - 7] while pressing and holding the  (IGNITION) button [See Figure - 8].

Step 3 Once burner lights release the  (IGNITION) button.

Step 4 Repeat procedure for second burner.

Step 5 WARNING: If the ignition does not light within 5 seconds, turn the burners to  (OFF) and wait 5 minutes for any gas to dissipate. Repeat prior steps or light using a match.

Step 7 After burners are lit, adjust the flame as desired between  and .

MATCH LIGHTING

If the appliance does not light using the steps above a match may be used to light the appliance.

Step 1 Turn on the gas tank valve.

Step 2 Attach a match to the lighting rod and light the match.

Step 3 Insert the match through the side of the firebox towards the burner [see Figure - 9] and immediately turn one of the burners to  (HIGH).

Step 4 Burner should light immediately. If the burner does not light, turn off the burners and gas valve on the tank and wait 5 minutes before trying again.

HOW TO TURN OFF APPLIANCE:

Step 1 Rotate both burners to the  (OFF) position [see Figure - 10].

Step 2 Turn off the gas supply.

WARNING: Turn off and disconnect gas supply when not in use.



NEVER cover slots, holes, or passages in the oven bottom or cover any rack or cooking surface with material such as aluminum foil. Doing so blocks air flow through the oven and may cause carbon monoxide poisoning.

WARNING

Aluminum foil linings may trap heat causing a fire hazard.

How to use

⚠ WARNING: Please completely read all safety precautions at the beginning of and throughout this guide before using the appliance. The appliance becomes extremely hot and can cause burns. Failure to follow precautions when using the Pizza Oven Box can result in serious injury and/or property damage.

STEP 1. Ignite the appliance according to the instructions on the previous page.

STEP 2. Set the burners to HIGH and preheat the Pizza Oven Box for 15 - 20 minutes.

STEP 3. Adjust the burner settings on the appliance to obtain the desired temperature range for the foods that are being baked. **NOTE: It will take 15 minutes for the temperature range indicator to function [see Figure - 11].**



Figure - 11
Temperature Range Indicator

For baking items such as Breads and Cookies, adjust the heat of the grill so that the indicator reads in the  baking zone.

For Pizza and Roasting Meats and Vegetables, adjust the heat so that the indicator reads in the  baking zone.

 = 200°-500°F
93°-260°C

 = 500°-800°F
260°-427°C

NOTE: Temperature range indicator is not an accurate measuring instrument.

STEP 4. Dust a Wooden Pizza Peel with flour (approximately 2 Tbsp of flour) and spread around board to evenly coat the entire peel. Then, holding the peel at a 45 degree angle over a sink, gently tap the peel to remove the excess flour. **NOTE:** This will ensure that the pizza does not stick to the peel when launching the pizza into the Pizza Oven Box.

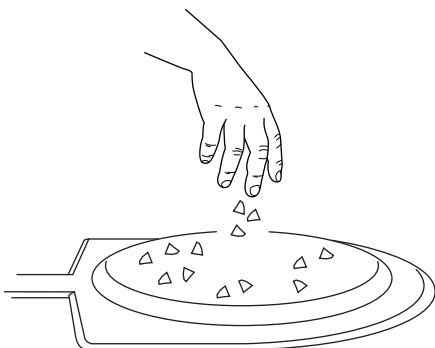

Figure - 12

STEP 5. Place a hand-stretched or rolled-out pizza dough on the floured Pizza Peel. Create your pizza using your favorite sauce and toppings [see Figure - 12].

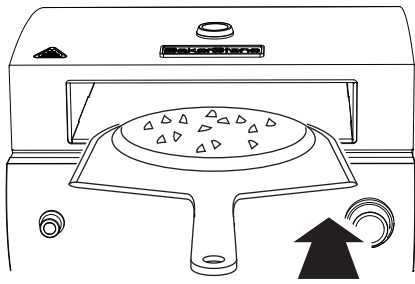

Figure - 13

STEP 6. Using the pizza peel, launch your pizza into the appliance [see Figure - 13].

NOTE: This can be accomplished by placing the pizza peel just over half-way into the appliance, and using a quick back and forth shaking motion while sliding the peel out of the appliance. See www.bakerstonebox.com website for a video demonstration.

WARNING: Failure to use pizza peel to insert pizza can result in serious injury.

NOTE: Do not allow food other than Pizza or Bread Dough to contact the stones. Any foods that contain fat, oil or butter (meats, items coated with olive oil, cookies, biscuits, etc.) should not contact the stones directly. These items should be baked in a metal baking pan, on a metal baking sheet or in a cast-iron skillet as the stones will absorb the fat, oil and butter which can cause smoking, odors, staining, and can impart rancid flavors to items that you bake in the future.

STEP 8. Bake the pizza for 1 minute* to allow the crust to set.

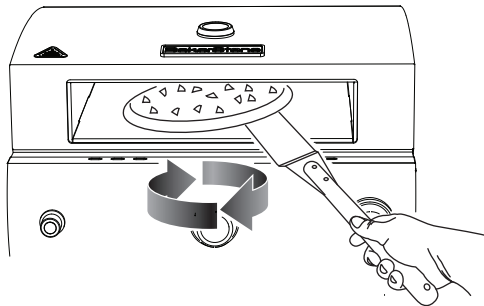

Figure - 14

STEP 9. After 1 minute*, use a long spatula or Pizza Turner to rotate the pizza 1/4 to 1/3 turns roughly every 45 seconds*. Bake your pizza for approximately 2-4 minutes*, being careful not to burn your pizza [see Figure - 14].

NOTE: The appliance is hottest in the back. Periodically rotate your pizza to ensure it is baked evenly.

WARNING: Touching the appliance anywhere with your bare hand or skin could cause serious injury.

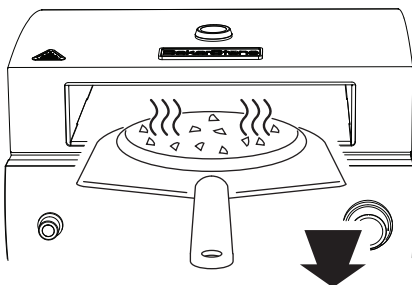

Figure - 15

STEP 11. Using a Metal Pizza Peel, remove the fully cooked pizza from the appliance and transfer to a cutting board or serving tray and allow to cool [see Figure - 15].

NOTE: The pizza will be very hot when you remove it from the appliance. **WARNING:** Removing the pizza with anything but the pizza peel could result in serious injury.

***Cooking times are provided as basic guidelines. Times can vary depending on weather conditions, gas grill condition and gas grill performance.**

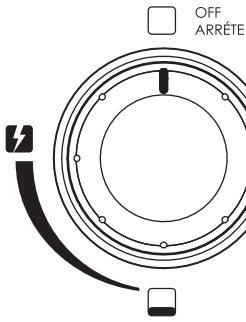

Figure - 16

Step 12. When finished baking, turn the burners on the appliance to the off position [see Figure - 16] and allow the appliance to cool for a period of at least ninety (90) minutes. **NOTE:** If cleaning is required, leave the burners on and continue to heat the oven for 15 minutes prior to cleaning. After cleaning, turn the burners on the appliance to the off position and allow the appliance to cool for a period of at least ninety (90) minutes [See Care and Cleaning instructions].

WARNING: Serious injury can occur if the appliance is not allowed to completely cool and you touch them.

Routine Care & Cleaning

Let the appliance cool completely before cleaning surfaces other than the stone baking chamber.

Do not use household cleaners or liquids on stones.

Do not use household cleaners on metal housing.

Wipe outer housing with a soft damp cloth only when completely cooled.

After baking your final pizza, you can clean the Pizza Oven Box by letting the burners remain on high for approx 15 minutes. Any residue should burn off and debris can be pushed to the back of the oven.

After allowing the appliance to completely cool, remove the grease tray [see Figure - 17] and wipe clean all residue. Replace the grease tray after cleaning.

If excess food or debris fell into the rear vent of the oven, remove the completely cooled Pizza Oven Box from the appliance and wipe clean the firebox [see Figure - 18] of the appliance.

Darkening of the stone from ingredients or excess flour will occur over time and will not affect baking performance of the Pizza Oven Box.

NOTE: Do not allow food other than Pizza or Bread Dough to contact the stones. Any foods that contain fat, oil or butter (meats, items coated with olive oil, cookies, biscuits, etc.) should not contact the stones directly. These items should be baked in a metal baking pan, on a metal baking sheet or in a cast-iron skillet as the stones will absorb the fat, oil and butter which can cause smoking, odors, staining, and can impart rancid flavors to items that you bake in the future.

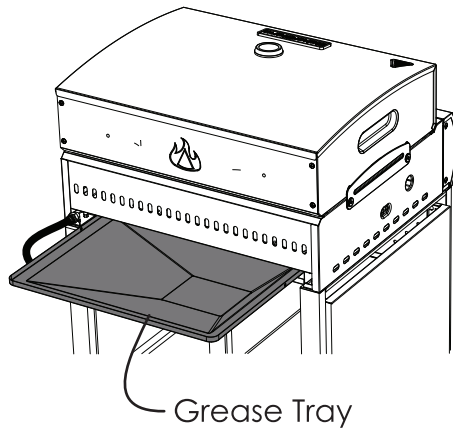

Figure - 17

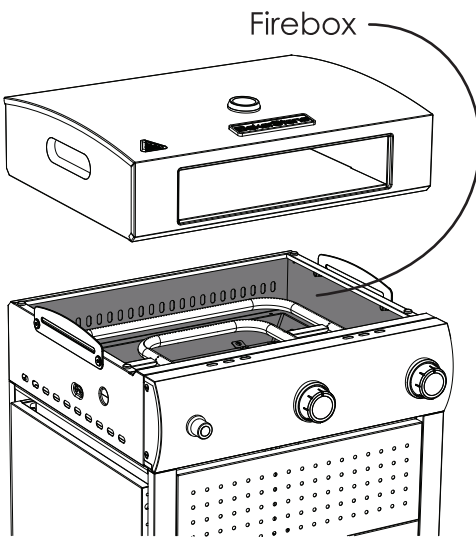

Figure - 18

Periodic Care & Cleaning of burner system

This appliance will periodically require more detailed cleaning after continued storage of 3 months or more. Periodically check and clean burner/venturi tubes for insects and insect nests. **WARNING: A clogged tube can lead to a fire beneath the appliance.**

Keep the appliance area clear and free from combustible materials, gasoline, and other flammable vapors and liquids.

Do not obstruct the flow of combustion and ventilation air.

Step 1 Working with a completely cooled appliance, turn off the LP gas cylinder valve and disconnect the LP gas cylinder from the appliance.

Step 2 Remove the Pizza Oven Box from the top of the appliance.

Step 3 Locate the fasteners attaching the igniters to the Burners. Remove these fasteners [see Figure - 19].

Step 4 Locate the fasteners attaching the Burners to the Burner Support Bar. Remove these fasteners [see Figure - 20].

Step 5 Lift the Burners up and towards the rear of the appliance to remove, taking care not to damage the gas valves. The gas valves are hidden between the firebox and control knobs. The Burners should come out freely [see Figure - 21].

Step 6 Clean the outside surfaces with a stiff brush to remove any debris or dirt. Inspect the Burners for any cracks or holes that appear out of place. If cracks or holes are present replace the Burner.

Step 7 Clean the inside of the Burners by inserting a stiff wire or small bottle brush into the inlet portion of the Burner. Compressed air may also be used to clean the burners by blowing air into the inlet portion of the burner and the air will flow out of the venturi holes.

Step 8 Replace the Burners by carefully inserting the Burners back into the firebox, taking care to avoid damaging the gas valves when installing.

Step 9. After reassembling the appliance, perform a leak test according to the instructions in this guide. Before placing the Pizza Oven Box or other cooktop on the firebox inspect the burner flames for proper combustion.

Step 10 Light the appliance according to the instructions provided in this guide and look at the flame emitting from the burners. A blue flame should emit consistently from each venturi hole on the burners [see Figure - 22]. The tips of the flame may occasionally flicker yellow while burning. **NOTE: The flame from the center burner will not be as great as the perimeter burner.**

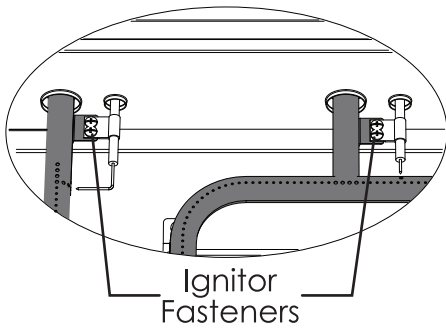

Figure - 19

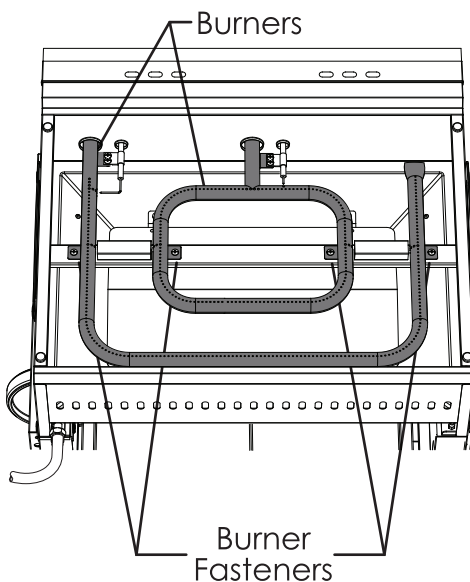

Figure - 20

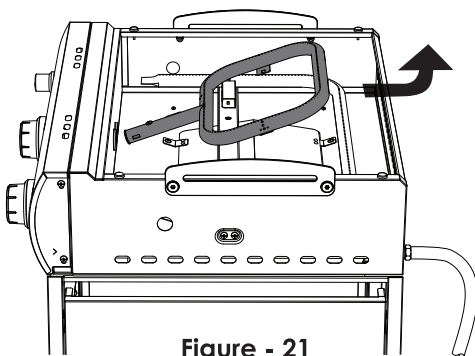

Figure - 21

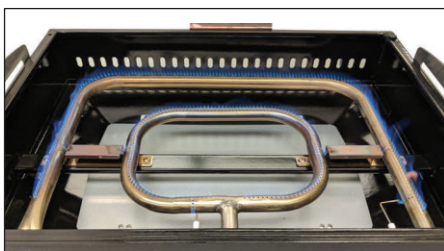

Figure - 22

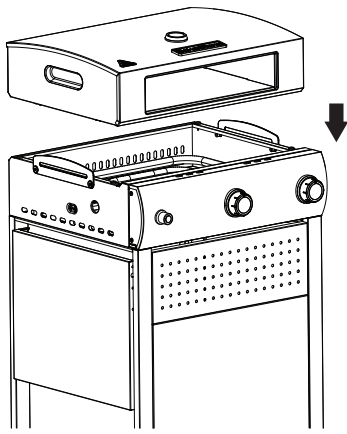

Figure - 23

Step 11. Turn off the appliance according to the instructions provided in this guide.

Step 12. With the appliance off and cool to the touch, place the Pizza Oven Box on top of the firebox [see Figure - 23].



Figure - 24

Step 13. To inspect the flame with the Pizza Oven Box in place, first ignite the burners according to the instructions provided in this guide.

Step 14. Once the burners have ignited, look through the match light hole in the side of the firebox to ensure the burners are lit [see Figure - 24].

Customer Service

For general inquiries, please email us at support@bakerstonebox.com or call (855) 657-6836.

For North American customer service needs, such as obtaining replacement parts and warranty claims, please email us at support@bakerstonebox.com or call (855) 657-6836.

CAUTION: The gas pressure regulator provided with this appliance must be used. Replace only with regulator Model Number TYQ-18A.

Warranty

Please read carefully:

This appliance is covered by/under a limited warranty for manufacturing defects for a period of 12 months from the date of purchase. This warranty applies only to the original purchaser using this product in a residential and non-commercial setting. This warranty applies only to items sold in original packaging, at the authorized retail location, and does not relate to items sold that have been opened, used as floor samples or demonstration, or models sold "as is".

When you open the package:

Consult the Product Guide to ensure that there are no missing or damaged parts. Within 14 calendar days from the date of purchase, any missing parts or damages must be reported to BakerStone. **NOTE: Slight chips or scratches in the stones are not considered damages and do not affect the performance of the appliance.**

Claims for defects or missing items must be accompanied by the original or an acceptable copy of the sales receipt and photographs must be taken to support any and all claims submitted.

Here is what the warranty does not include:

- Merchandise that has sustained weather damage.
- Broken stones occurring or reported more than 14 days after purchase.
- Any damage to the appliance resulting from being used in a manner other than its intended purpose.
- Damages resulting from use in a commercial or institutional organization.
- Failures, defects, damages caused by, failure to follow the instructions, abuse, neglect, inclement weather and/or acts of nature.
- Reasonable wear and tear of enameled finishes.
- Discoloration of the stone baking chamber.
- Discoloration or yellowing of any stainless steel components.
- Damage caused by bleach, ammonia, and/or other abrasive cleaners.
- Rusting as a result of scratches or broken enameled surfaces.
- Failure, discoloration or any and all damages that result from the appliance being used with disregard to any and all warnings listed in the Product Guide
- Damages caused to the appliance by dirty, grease laden firebox or burners that are clogged, corroded or otherwise damaged and therefore are likely to misfire or otherwise malfunction.
- Damages caused by neglect or lack of reasonable care and maintenance.
- Damages resulting from the use of the appliance when it has not been properly maintained. A properly maintained appliance includes, but is not limited to, clean grease trap and firebox, and properly functioning burners, valves and regulator.
- Consequential damages.
- Any damages to an item resulting from placing it on a hot appliance.
- Damage to any item resulting from attempting to use the appliance indoors.

Disclaimer

Use of this appliance is at the discretion of the user. BakerStone is not responsible for personal injury or property damage resulting from the misuse of this appliance.

FAILURE TO NOT FOLLOW THE PRECAUTIONS AND INSTRUCTIONS IN THE PRODUCT GUIDE MAY RESULT IN THE VOIDING OF THE WARRANTY OF THIS APPLIANCE.

THE PIZZA OVEN BOX IS FOR OUTDOOR USE ONLY.

Customer service claims - Please call: 1-855-657-6836

Email: support@bakerstonebox.com

Visit: www.bakerstonebox.com

NOTE: Temperature range indicator is not an accurate measuring instrument.

For all product inquires in Australia please contact:

Freephone: 1800 839 842
customercare@bakerstonebox.com.au
visit www.bakerstonebox.com.au

**For all product inquires in New Zealand
please contact the New Zealand Distributor:**

Riverlea Group Ltd.
Freephone: 0800 438 274
customercare@riverleagroup.co.nz
www.riverleagroup.co.nz

For all product inquires in Europe please contact:

OutTrade B.V.
+31 529 48 28 08
info@outtrade.eu
www.outtrade.eu

Frequently Asked Questions

Why is my Pizza Oven Box not lighting?

- LP Gas Cylinder Valve turned off.
- LP Gas Cylinder out of fuel.
- Excess flow limiting device may have been activated. To deactivate:
 1. Turn all burners to the OFF position.
 2. Close LP Gas Cylinder valve and disconnect regulator.
 3. Wait 1 minute and re-connect regulator to LP Gas Cylinder.
 4. Slowly open LP Gas Cylinder valve and perform leak test.
 5. Upon completing leak test procedures try igniting appliance normally.
- Coupling fastener on LP gas hose is not connected correctly.
- Battery in Ignitor needs to be replaced
- Faulty Ignitor.
- Burner tubes are clogged or blocked.

Why is my Pizza Oven Box not getting hot enough?

- LP Gas Cylinder Valve turned off.
- LP Gas Cylinder out of fuel.
- Coupling fastener on LP gas hose is not connected correctly.
- Check for kinks in the LP gas hose.
- Check for inconsistent flame on the burners, clean if necessary.

What can I do if the pizza is stuck to the wooden peel and cannot be launched into the oven?

If your unbaked pizza is sticking to the wooden peel, carefully lift the edge of the pizza and toss a small amount of flour under the dough. Continue around the perimeter of the pizza, lifting and adding small amounts of flour so the area below the dough has a fine coating of flour and the pizza can freely move on the wooden peel.

