

# **FIRST TEAM SPORTS, INC.**

## **FANSTAND TIP N ROLL BLEACHER ASSEMBLY**



These instructions are to be used in the assembly of First Team Sports' FanStand Tip N Roll bleacher system. Read and follow the instructions carefully. Assembly should only be performed by skilled persons with a basic knowledge of mechanics. **REMEMBER: Bleachers can be dangerous. Their use can result in bodily injury or death. Improper assembly can/will increase the chances of an accident!**

If you have questions about the assembly or use of this bleacher design, contact First Team Sports, Inc. 1-888-884-6677

### **REQUIRED TOOLS:**

Assembly of this bleacher design requires the use of basic tools. The following is a minimum recommended set of tools required.

- 1 or more - 3/8" socket wrench(s) & extension driver(s)
- 1 or more - 1/2" & 9/16" socket(s)
- 1 or more - 1/2" & 9/16" combination wrench(s)
- 1 each - Framing Square
- 1 each - Tape Measure

### **STEP 1: UNLOAD/UNPACK PRODUCT**

Always check for damaged parts as the product is removed from the shipper's truck. Damage to any items should be reported to the shipping company before signing for the receipt of the product. It may be necessary to remove planks from the truck one plank at a time. Additionally, a forklift would be useful for additional boxes and other heavy packaging (Bleacher Frames, etc.).

Depending on the bleacher style and number of bleachers shipped, packaging will vary to provide the best shipping rate possible. All like parts and pre-assemblies are inter-changeable and may be package together for best packaging solutions. Only the total count as provided on the attached packing list is required for complete assembly of your bleacher(s). Prior to assembly make sure all bleacher components are on hand.

## STEP 2: BASIC ASSEMBLY RULES

Following are basic rules that must be followed in order to properly assemble your bleachers.

**Rule 1:** All fasteners must be Grade 5 or equivalent. Grade 5 fasteners can be identified by 3 opposing marks on the head of the fastener.

**Rule 2:** When using a hex-head fastener or hex-nut over a slotted hole always use a flat washer over the slotted hole.

**Rule 3:** Always use a split lock washer on the nut side of each fastener.

**Rule 4:** Do all assembly on a level surface. If floor damage is a concern, use protective covering/plywood or other protective materials under your work area.

**Rule 5:** Generally, do not tighten fasteners until all associated parts are in place and squared to each other. After each phase of assembly is completed, make sure all fasteners are then tightened.

**Rule 6:** Constantly check squareness of assembly as work progresses.

## STEP 3: FRAME ASSEMBLY

Attach the rubber foot pads to the bottom of each frame. Insert the provided carriage bolts (5/16" x 2") from the bottom side for the rubber foot pad up through the frame. Make sure the carriage bolt head is recessed into the rubber foot pad so as to prevent floor damage. Use the provided hardware (5/16" nut, lock washer, and flat washer) on top of the frame to secure the carriage bolt.

## STEP 4: WHEEL ATTACHMENT

All low rise bleachers are designed for the attachment of casters to the back of the frame. If you have purchased the optional wheels they can be attached at this time. Or, these wheels can be purchased and attached at a later time. Wheels are only attached to the frames at each end of the finished bleacher assembly.

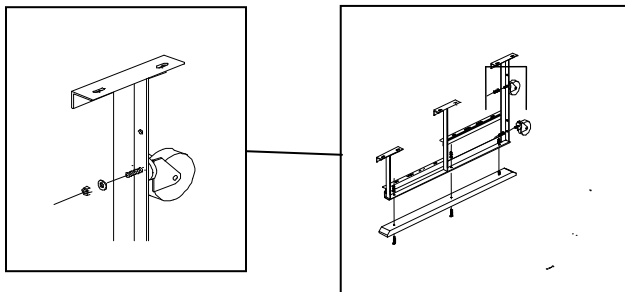

## STEP 5: ATTACH CROSS BRACES

Space frames at 72" intervals (center to center). Attach the horizontal and cross braces using the provided hardware (3/8" x 2" hex bolts). Bolts should be inserted from the back side of the bracing toward the front. Use the appropriate hardware (3/8" hex nut, lock washer, and flat washer) to secure the bolt on the front side.

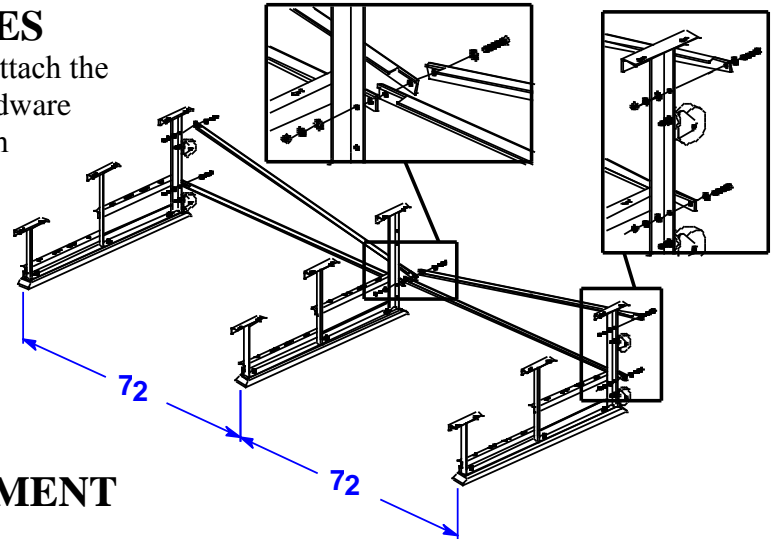

## STEP 6: SEAT PLANK ATTACHMENT

Position each seat plank onto the top of each seat support bracket. Adjust the position of each plank so it is positioned in the center of the bracket and so the plank extends beyond the center of each support frame the same at each end of the bleacher. Attach each seat plank to the seat support brackets using the provided pressure clamps and provided hardware (5/16" x 1 1/2" carriage bolt). Use two clamps per plank attachment location. Make sure both sides of each pressure clamp locks down and over each plank rib. Use a 5/16 hex nut, lock washer and flat washer to secure the carriage bolt.

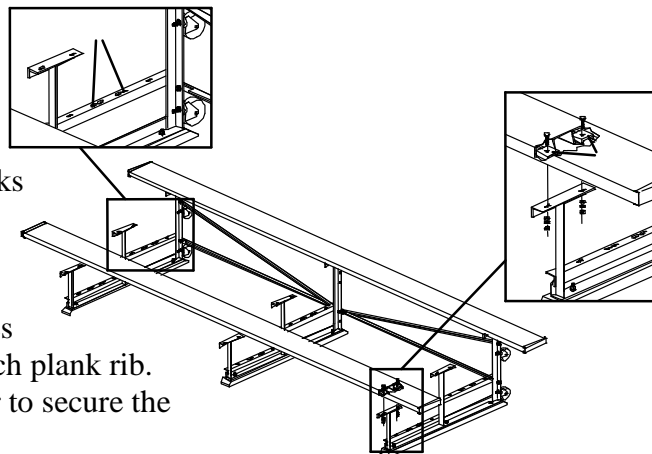

If you are using a single walk plank use the slotted holes on the horizontal support as referenced in the above drawing to attach the plank. If using a double walk plank use the remaining holes in the horizontal support bracket. Adjust the walk planks to align with the ends of the seat planks. Use the same pressure clamps and hardware as used on the seat clamps, to secure the walk planks.

## STEP 7: CHECK FOR LOOSE BOLTS AND SCREWS

The bleacher should now be fully assembled. Go back and recheck to make sure all bolts and screws are tight. Loose hardware is a hazard! Although, this bleacher system requires very little maintenance, from time to time check the general condition of the bleacher. Pay close attention to welded areas and loose bolts.

# WARNING – CAUTION – WARNING

Bleachers can be dangerous! The following must always be observed with the use of this equipment.

- Use of this bleacher must be on level hard surfaces only.
- Never allow children to climb or play on bleachers.

- Never place bleachers in a location near other hazards (electrical power lines, swing up basketball goals, excessively close to lights, or excessively close to over head fans, etc.).
- Maintain a safe distance from aggressive sporting activities to avoid spectator injury or injury to those involve in an activity where contact with the bleacher is possible.
- Do use if bleacher surface is wet, or slippery.
- Make sure all seat planks are firmly bolted / locked in place.
- Never stand or walk on seat planks for any reason.

**For more information on First Team Sports, Inc.  
Check us out at: [www.firstteaminc.com](http://www.firstteaminc.com)**