



WARRANTY & RATING



SPECIFICATIONS

- Wattage: 120W/96W/72W
- Voltage: 120-277V
- Luminous Flux: 15600lm (120W), 12400lm (96W), 9300lm (72W)
- Beam Angle: 120°
- Color Rendering Index (CRI): 80+
- Lifespan: 50,000 Hours
- Light Source: LED
- Color Temperature (CCT): 3000K/4000K/5000K - 3CCT adjustable
- Waterproof Rating: IP65
- Operating Temperature: -40°C to 45°C (-40°F to 113°F)
- Material: Aluminum , PC

PRODUCT DESCRIPTION

Ideal for barns, yards, and rural areas, these LED barn lights feature an integrated photocell for automatic dusk-to-dawn operation. Mounting is versatile: directly on walls with included hardware or on poles using an optional mounting arm (not included). They provide durable, waterproof illumination perfect for withstanding harsh weather conditions.

FEATURES & BENEFITS

- Certified by UL, FCC and DLC, ensuring safety, efficiency, and compliance
- Compatible with 277V U.S. commercial voltage
- Integrated photocell for automatic dusk-to-dawn operation
- Bypass the photocell via the DIP switch
- Adjustable power settings: 120W, 96W, 72W
- Dimming capability: 0-10V, adjustable from 20% to 100%
- 3CCT adjustable, one product fits multiple project needs

POWER AND ELECTRICAL FEATURES

- Certified by UL, DLC, and FCC. Operates on 120-277V AC, compatible with US 277V commercial voltage. It has a 1.1A current with three power settings: 120W, 96W, 72W, producing luminous fluxes of 15600lm, 12400lm, and 9300lm respectively, at 120W power, it is equivalent to a 400W incandescent bulb.
- Utilizes tinned copper, with SVT 18AWG3 for power and UL2464 18AWG2 for 0-10V dimming, each 0.5m long.
- Features a non-isolated (partially potted) design with a power factor greater than 0.9.

DESIGN AND STRUCTURE

- Designed for ease of installation on walls or poles, our LED barn lights include necessary hardware. The optional mounting arm, required for pole mounting, is sold separately, enhancing adaptability for various settings in commercial or residential areas.
- These robust LED barn lights are waterproof and built to withstand harsh weather conditions. Featuring an integrated photocell for automatic lighting from dusk to dawn, some models also offer adjustable color temperature and wattage, providing tailored lighting solutions.

ADDITIONAL COMPONENTS

- Pole Mounting Clamp
- Arm Wiring Cover
- American P3 Wire Terminal
- Stainless Steel Pan Head Self-tapping Screw M6*50
- M6 Flat Washer
- M6 Plastic Anchor
- Stainless Steel M8*20 Screw (pre-installed)
- M8 Flat Washer (pre-installed)
- M8 Spring Washer (pre-installed)

LED AND OPTICAL PERFORMANCE

- Supports 0-10V dimming (20%-100%).
- Equipped with 480 SMD 2835 LEDs, each 1W and 53mA, achieving 125-135LM at 3000K and 130-140LM at 5000K. Offers adjustable 3CCT: 3000K, 4000K, 5000K, with a CRI of ≥ 80 .

PRODUCT DIAGRAM

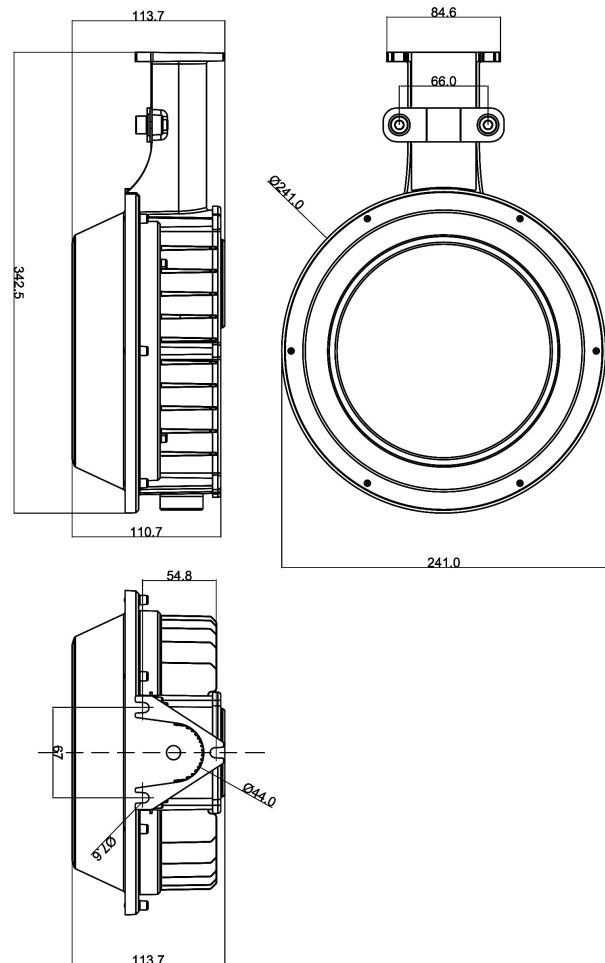

Size in mm
 1" = 25.4mm.

PHOTOMETRICS

Distance (ft)	Beam Spread (ft)	Illuminated Area (sq ft)	Footcandles
10	35	942	15.9
15	52	2121	7.1
20	69	3770	4.0
25	87	5890	2.5
30	104	8482	1.8

Note: Our PHOTOMETRICS are for reference only, reflecting ideal conditions.

