

Eye Washer GI-B100

Wall Mounted Eye Washer, Galvanized Steel, Model: B100



M339670922

Features:

- Controlled, low velocity flow and uninterrupted water supply at 3gpm
- Deliver 11L of water per minute
- Valve actuator are easy to locate and readily accessible to user
- Handsfree stay open valve activate within one second

Supply: 1/2" NPT male inlet

Waste: 1-1/4" NPT female outlet

Spray Head Assembly: Two spray heads, each head has a dust cover, internal flow control, and filter to remove impurities from water flow

Bowl: 11-1/2" diameter ABS plastic bowl

Valve: 1/2" stainless steel stay-open ball valve

Standard:

- EN 15154-1:2006
- EN 15154-2:2006

Packing:

- 1 piece / packet
- 1 packet / carton

Carton Dimensions:

52 x 30 x 28 cms

Carton Weight:

- Gross Weight: 5.2 kgs. / carton
- Net Weight: 4.3 kgs. / carton

Volume:

CBM 0.0437

Origin:

China

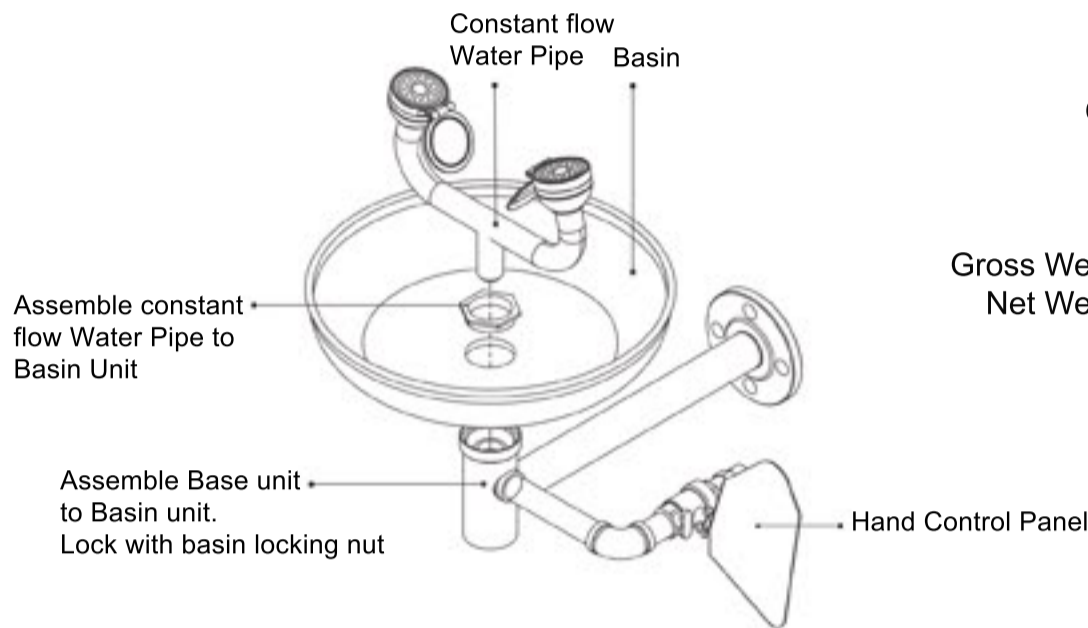

Applications:

Where the eyes and face of any person may be exposed to injurious or corrosive materials, suitable facilities for quick flushing of the eyes & face must be provided within the work area for immediate emergency use



Eye Washer GI-B100

Wall Mounted Eye Washer, Galvanized Steel, Model: B100

Assembly & Design Specifications

