

Portable Eye Washer P150

9-Gallons, Portable Type Eye Washer, Model: P150



Features:

Self-contained 9-gallon gravity flow eyewash unit uses gravity to deliver water through dual spray heads. Delivers over six gallons (22.5L) of water for 15 minutes.

Tank: 9gallon capacity safety yellow polyethylene tank, handles on top and side for easy handling

Operation: Water flow is activated by pulling down the yellow eyewash tray. Integral full flow nozzles deliver soft spray of water

Drain: Wastewater is directed to discharge into the floor drain. A storage tank or other receptor could be used to collect waste water to avoid pollution (not included)

Mounting: Stainless steel bracket for a mounting unit on the wall

Discharge time: 15 minutes (minimum) at the flow rate of 1.5L/minute (minimum)

Standard:

EN 15154-4:2009

Packing:

1 piece / packet
1 packet / carton

Carton Dimensions:

61 x 27 x 38 cms

Carton Weight:

Gross Weight: 5.6 kgs. / carton
Net Weight: 4.7 kgs. / carton

Volume:

CBM 0.0626

Origin:

China

Applications:

Where the eyes of any person may be exposed to injurious or corrosive materials, when suitable facilities for quick flushing of eyes need to be provided and a continuous supply of water is not available. Although it may be installed in a wide variety of locations, it is ideal for the remote & low traffic areas where protective measures are still needed



M339670821

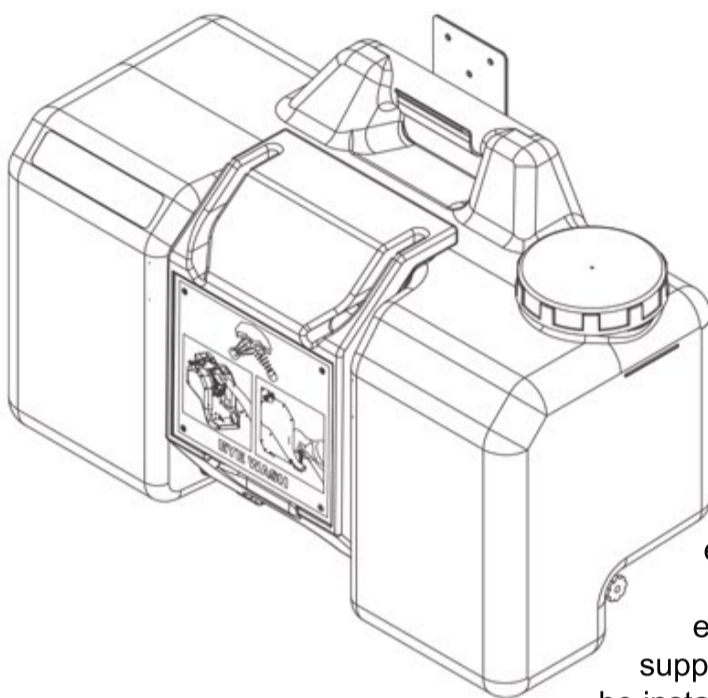

Portable Eye Washer P150

9-Gallons, Portable Type Eye Washer, Model: P150

Assembly & Design Specifications

