

# MODEL WP10F/WP20F

3 1/2" x 5 1/2" / 7" x 7" Cutout Insert

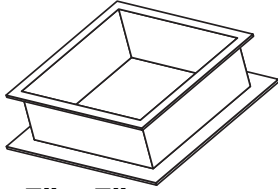

Customer Service  
(800) 247-7668



7" x 7"

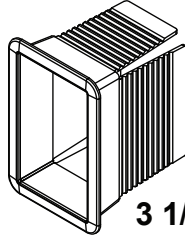

3 1/2" x 5 1/2"

## Step 1:

Lay wall pad flat on the ground with wood backing facing upward.

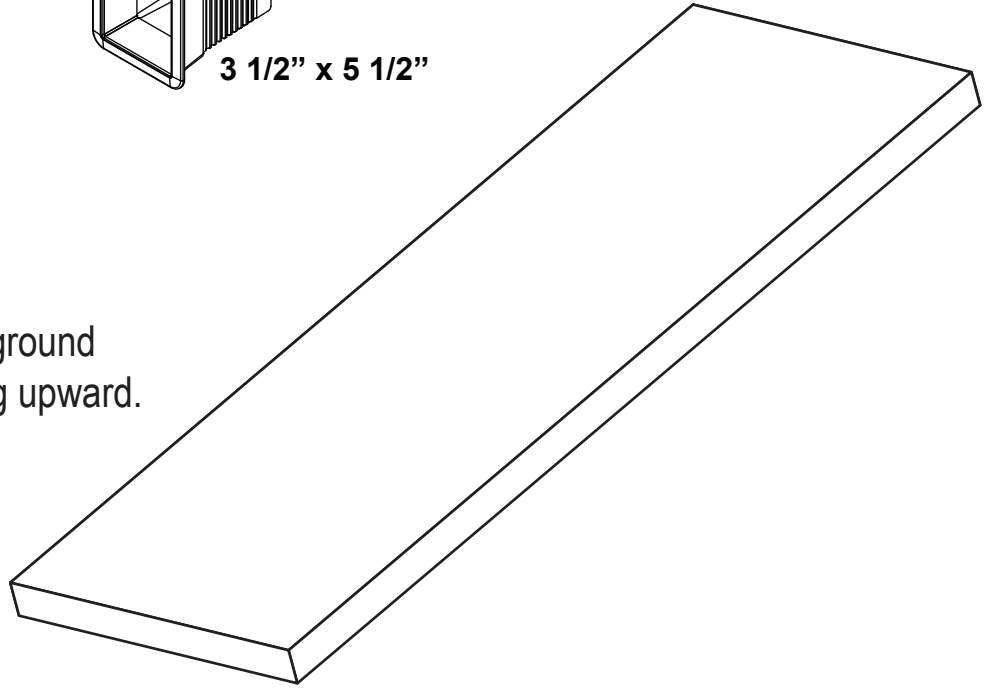

## Step 2:

With a pencil, draw square in the desired cutout position.

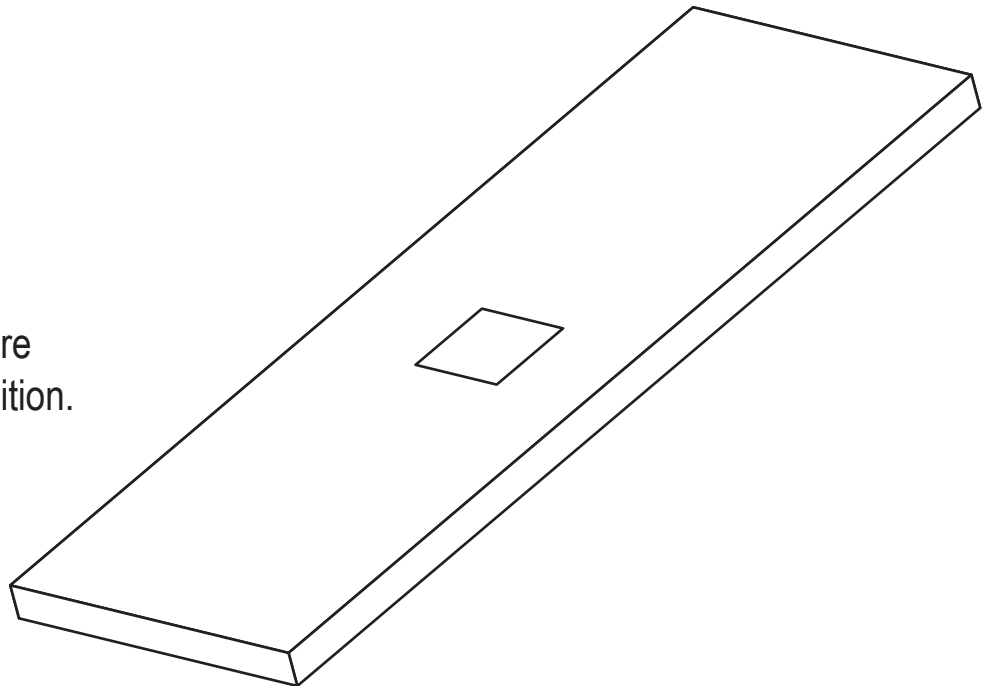



Customer Service  
(800) 247-7668

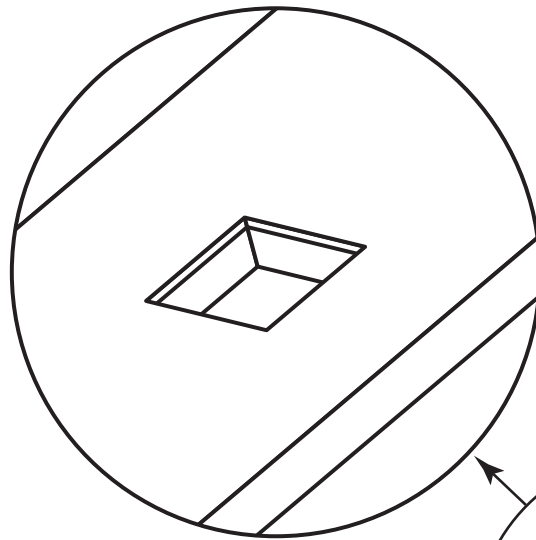

**Step 3:**

With a jig saw, carefully cut out the square from the wood.

Use an electric knife to remove the foam, leaving the vinyl exposed.

**(DO NOT CUT VINYL)**

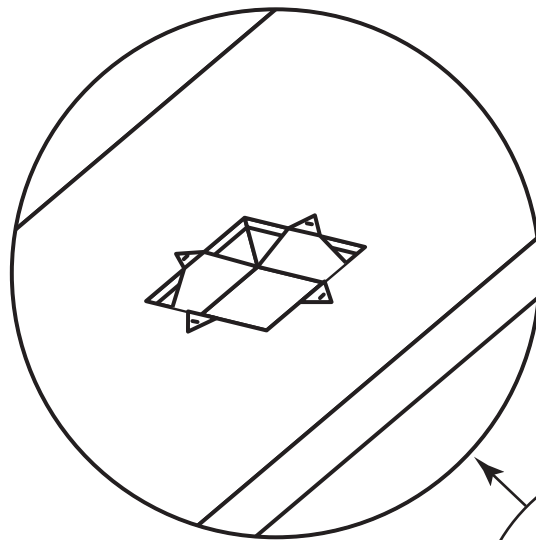
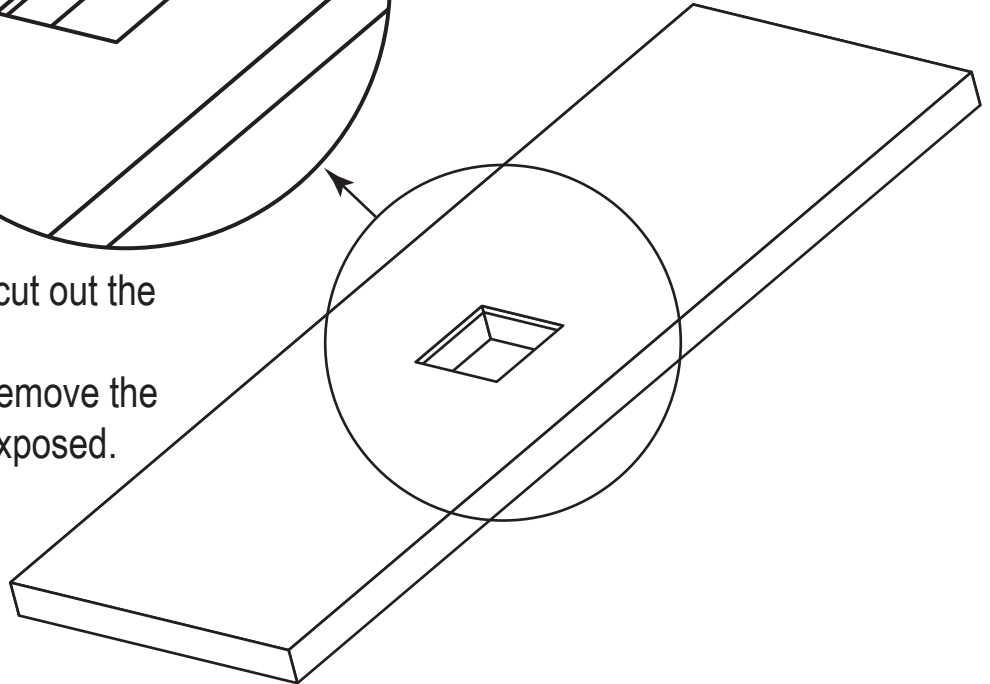
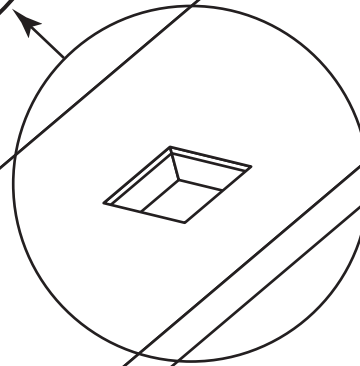

**Step 4:**

Make an "X" cut in the exposed vinyl.

Pull corners from "X" cut to back side of pad and staple each corner to wood backing.

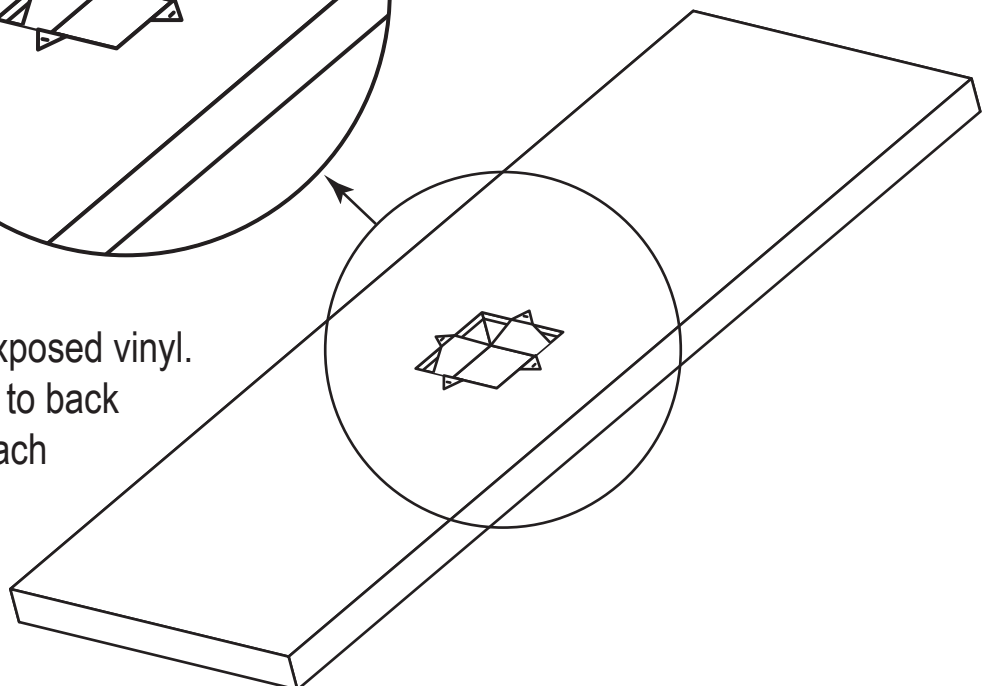
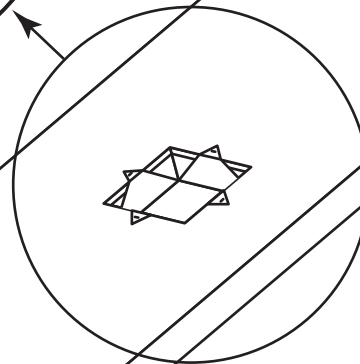



Customer Service  
(800) 247-7668

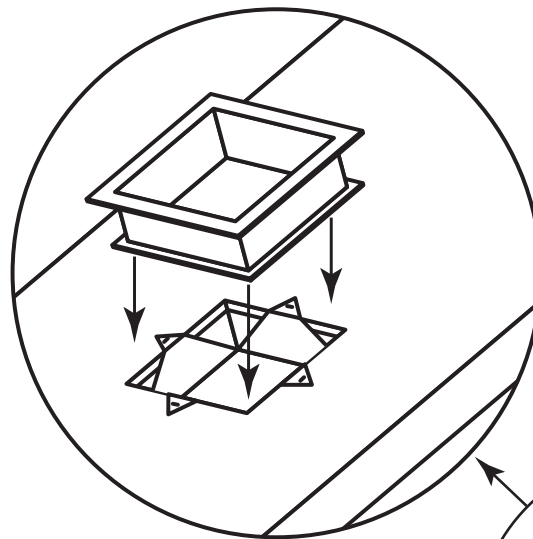

**Step 5:**

For 7" x 7" kit, place the rubber insert into cutout opening from the back side of the wall pad.

For 3 1/2" x 5 1/2" kit, place the rubber insert into cutout opening from the front side of the wall pad.

*(Note: Super Glue may be used under front lip for better adhesion)*

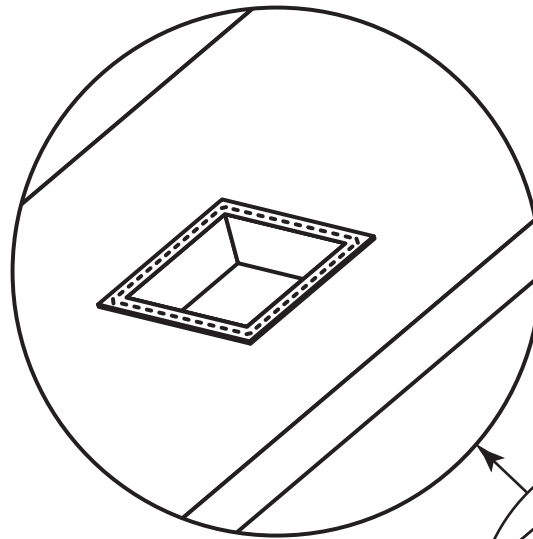
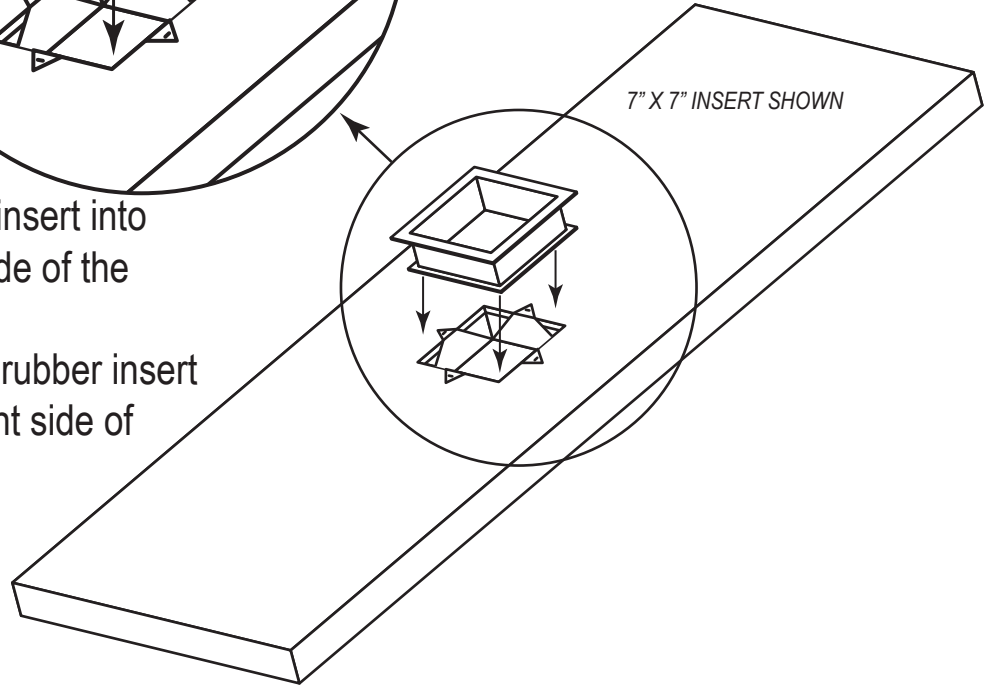

**Step 6:**

Once insert is in place, use a staple gun and insert multiple staples around 7" x 7" insert lip to finish securely.

For 3 1/2" x 5 1/2" insert, fold flanges back to wood backer and insert multiple staples in each flange to secure.

