

VB8200 AND VB8250

QwikCourt Volleyball Systems



Customer Service
(800) 247-7668

PARTS LIST					
Item	Qty	Description	Item	Qty	Description
A	2	Base	M	18	3/8" Hex Nut
B	2	Base Lid	N	2	1/2" X 6 1/2" Hex Bolt
C	2	Pivot Bracket	O	2	1/2" Lock Nut
D	2	Extension Tube	P	8	1/4" X 3/4" Screw
E	2	Adapter Socket (VB340 or VB354)	Q	2	Lock Pin
F	2	Lock Knob	R	36	4" X 8" X 16" Solid Cap Block (BA833BLST)
G	4	Floor Lock	S	2	2 Piece Base Pad
H	2	Bumper Spacer	T	2	Extension Tube Pad
I	2	Bumper	U	2	Pole Pad
J	16	3/8" X 1" Carriage Bolt	V	2	Volleyball Post (VB10 or VB60)
K	2	3/8" X 2" Carriage Bolt	W	2	Volleyball Net (VB1250K)
L	18	3/8" Lock Washer	X	4	Sideline Antennae (VB13)

- ◆ Inspect all contents prior to installation. Report any missing parts to dealer immediately.
- ◆ Read all instructions before proceeding.

Warning!

While gym floor installers and refinishers often indicate floors are OK to walk or play on in 7-10 days after oil based polyurethane finishes are applied, in reality, it can actually take up to 30 days for all the chemicals in the polyurethane to dissipate. Chemical reactions between the floor finish and certain materials including urethane feet contacting the floor can cause permanent discoloration. Placement of this product on floors prior to the 30-day final cure period may risk discoloration that would not be covered by the manufacturer's warranty.

1. Remove *1/4" X 3/4" Screws (P)* and *Base Lid (B)*. Remove hardware package and *Pivot Bracket (C)* from inside of *Base (A)*. See Figure 1.
2. Attach *Pivot Bracket (C)* to the front of *Base (A)* using *3/8" X 1" Carriage Bolts (J)*, *3/8" Lock Washers (L)* and *3/8" Hex Nuts (M)*. Install *Bumper Spacer (H)* and *Bumper (I)* into the center hole of *Pivot Bracket (C)* using *3/8" X 2" Carriage Bolt (K)*, *3/8" Lock Washer (L)* and *3/8" Hex Nut (M)*. See Figure 1.
3. Load eighteen each *4" X 8" X 16" Solid Cap Blocks (R)* into *Base (A)* for ballast. Order 2 ea. BA833BLST or *4" X 8" X 16" Solid Cap Blocks* can be purchased at any local home improvement center or hardware store.
4. Replace *Base Lid (B)* onto *Base (A)* with *1/4" X 3/4" Screws (P)*. See Figure 1.

Warning!
This system requires ballast to be installed prior to use. Tip over or damage could occur without the proper ballast installed.

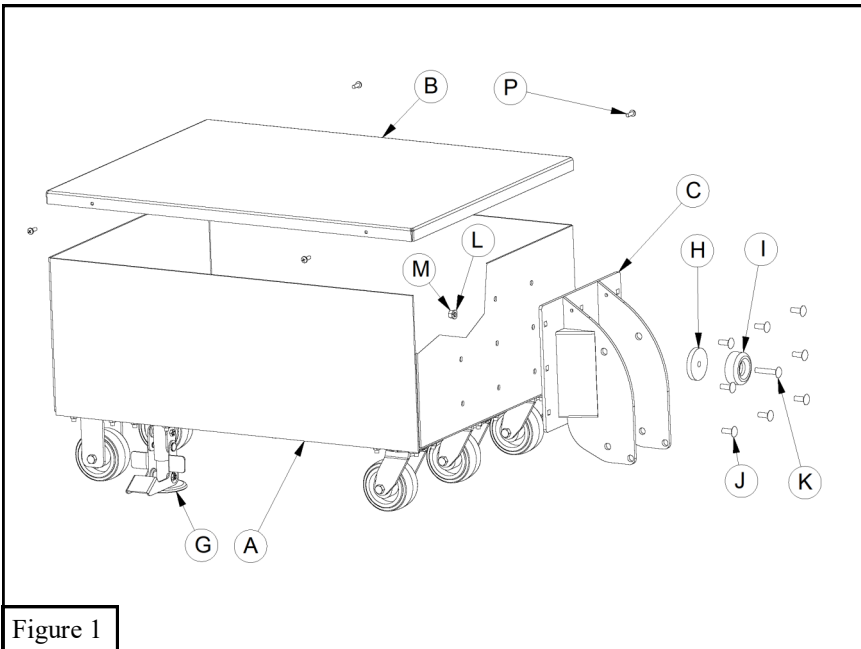

Figure 1

Warning!
Both Rear Floor Locks (G) must be engaged during play and at all times when rotating Extension Tube (D) to play or storage position.

5. Use $1/2"$ X $6 1/2"$ Hex Bolt (N) and $1/2"$ Lock Nut (O) (not shown) to attach Extension Tube (D) to Pivot Bracket (C). Do not overtighten, make sure Extension Tube (D) rotates freely. See Figure 2.
6. Lock Pin (Q) is used to stabilize Extension Tube (D) during play and secure Extension Tube (D) during transport. See Figures 2 and 3.
7. Install Adapter Socket (E) into socket on Extension Tube (D)
8. Insert Volleyball Post (V) into Adapter Socket (E) and tighten Lock Knob (F) to retain Volleyball Post (V) securely in the socket on Extension Tube (D)
9. Follow instructions provided with the Volleyball Posts (V) for Volleyball Net (W) attachment and Volleyball Net (W) height adjustment.
10. Install 2 Piece Base Pad (S) on Base (A), Extension Tube Pad (T) on Extension Tube (D) and Pole Pad (U) onto Volleyball Post (V). See Figure 4.

Notice:
2 Piece Base Pad (S) is designed to be folded over toward the back of the Base (A) to allow all padding to remain attached when Extension Tube (D) is rotated to the store/transport position. MAKE SURE LOCK PIN (Q) IS INSTALLED PRIOR TO TRANSPORTING SYSTEM.

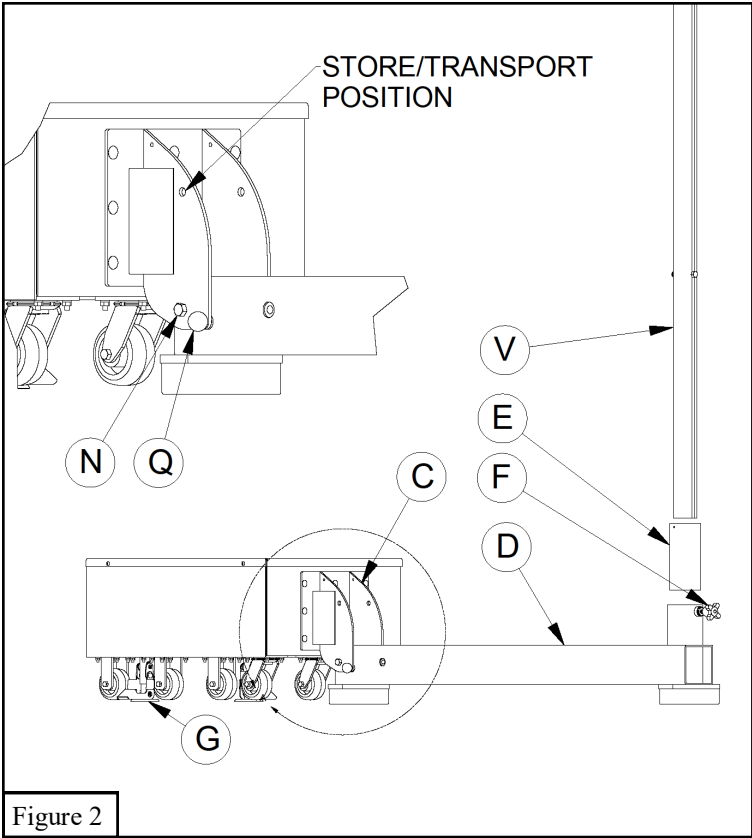

Figure 2

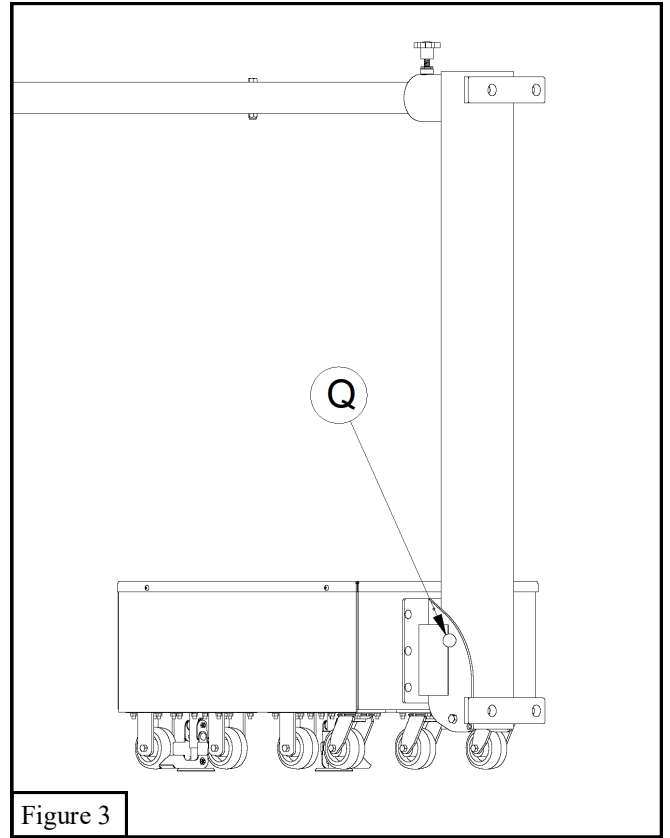

Figure 3

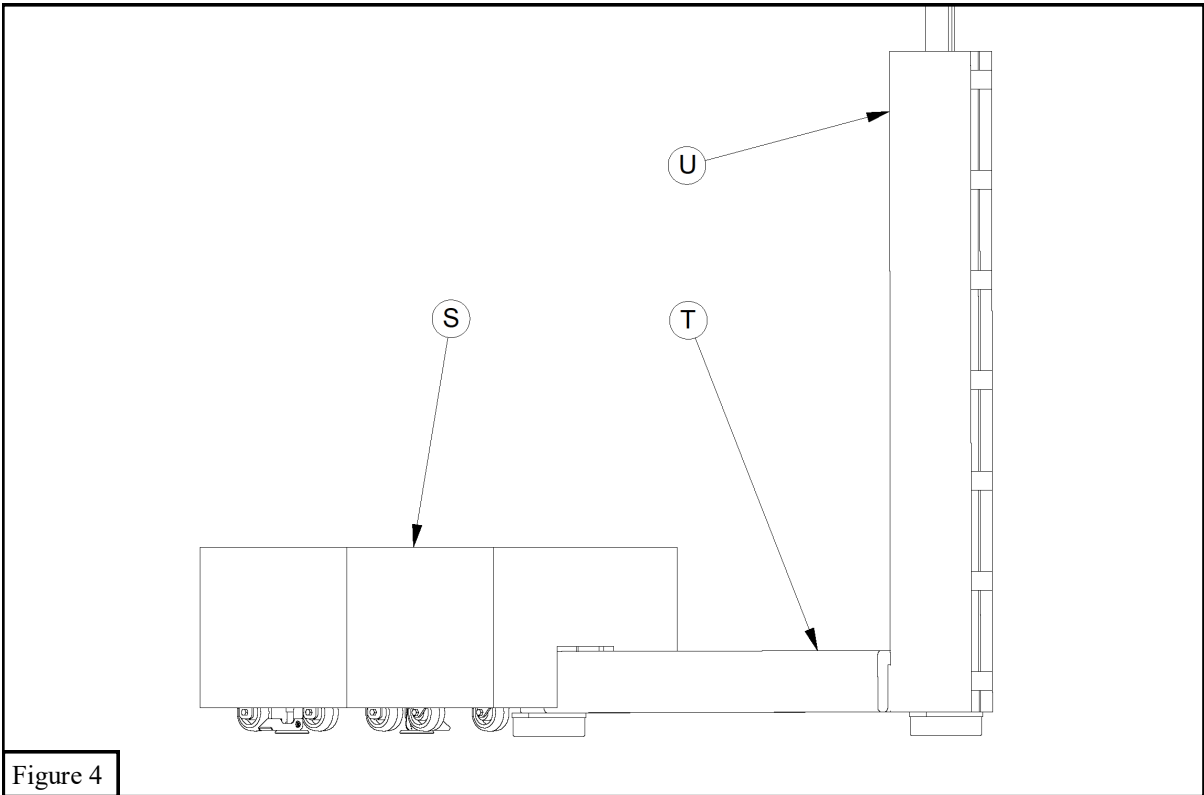

Figure 4