

TN10

Competition Tennis System

PARTS LIST

Item	Qty	Description	Item	Qty	Description
A	1	Winch Post	E	1	TN10CS Center Court Hold Down Strap
B	1	Non-Winch Post	F	1	TNCSA Center Strap Anchor
C	1	Removable Winch Handle	G	2	Lacing Cord
D	1	TN10N Tennis Net			

- ◆ Inspect all contents prior to installation. Report any missing parts to dealer immediately.
- ◆ Read all instructions before proceeding.

1. Use the attached court diagram to determine where to locate and dig two 8" round and 48" deep holes 42 feet apart. See Figure 1.
2. Insert *Winch* (A) and *Non-Winch* (B) posts into the holes with the lacing bars facing the tennis court and fill holes with concrete. Each hole will require between 6 and 8 1/3 cubic foot bag of concrete. Make sure to brace post while concrete is curing to maintain the 42 1/2" dimension and ensure the post remain perpendicular to the court surface. See Figure 1.
3. Dig one 8" round and a minimum 12" deep hole centered between the two tennis posts (make sure to bell out the bottom of the hole). Insert *TNCSA Center Strap Anchor* (F) with the strap retaining bar running parallel with the *TN10N Net* (D) and fill hole with concrete. The hole will require 2 to 3 1/3 cubic bags of concrete. See Figure 2.
4. Concrete must cure 7-10 days before continuing with *TN10N Tennis Net* (D) installation.

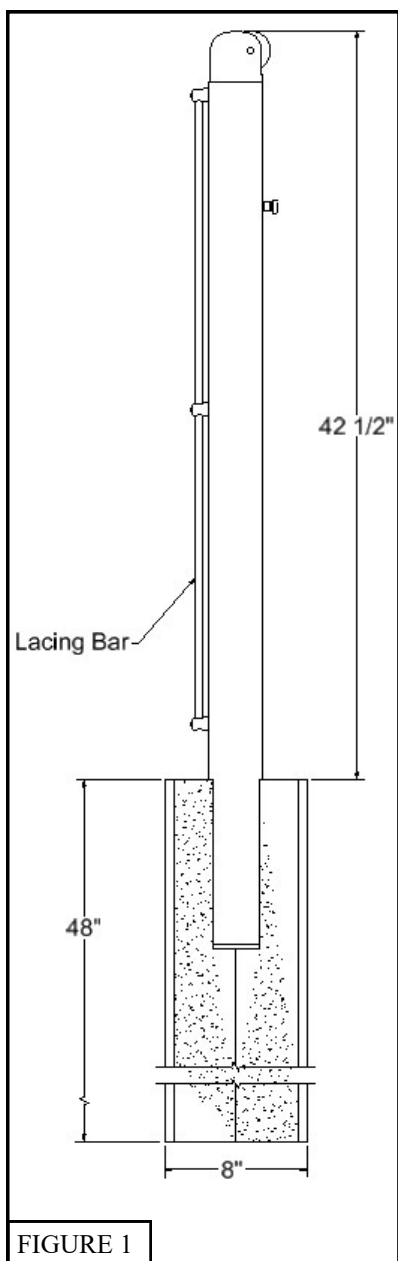

FIGURE 1

Note:
Use models VB23 or VB235 for removable post installation

5. Stretch out *TN10N Tennis Net* (D) across the court.

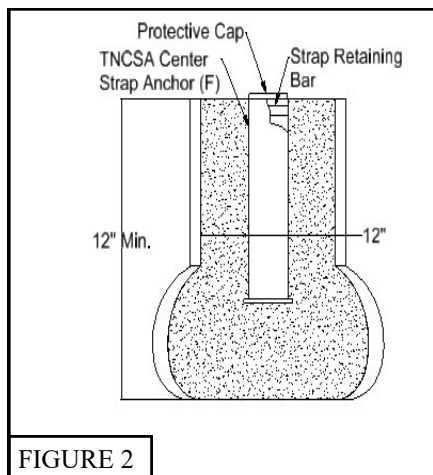

FIGURE 2

6. Hook the loop on the *TN10N Tennis Net* (D) top cable around the net retaining pin on *Non-Winch Post* (B) and over the top pulley. See Figure 3.
7. Cut off loop and remove 12" of nylon cable coating from the top net cable, run cable over the top groove of the net cable pulley down the outside of the post. Insert cable into the winch cable hole on the *Winch Post* (A). Use the *Removable winch Handle* (C) to crank cable until you achieve 38" at the center of *TN10N Tennis Net* (D). See Figure 4.

8. Insert dowels through the end side tapes of *TN10N Tennis Net (D)*.
9. Square up *TN10N Tennis Net (D)* to each post, use *Lacing Cord (G)* to secure *TN10N Tennis Net (D)* to each post. See Figure 3.
10. Attach *TN10CS Center Court Hold Down Strap (E)* to the strap retaining bar in the *TNCSA Center Strap Anchor (F)*. Adjust *TN10CS Center Court Hold Down Strap (E)* so top of *TN10N Tennis Net (D)* measures 36" at the center. See Figure 2.

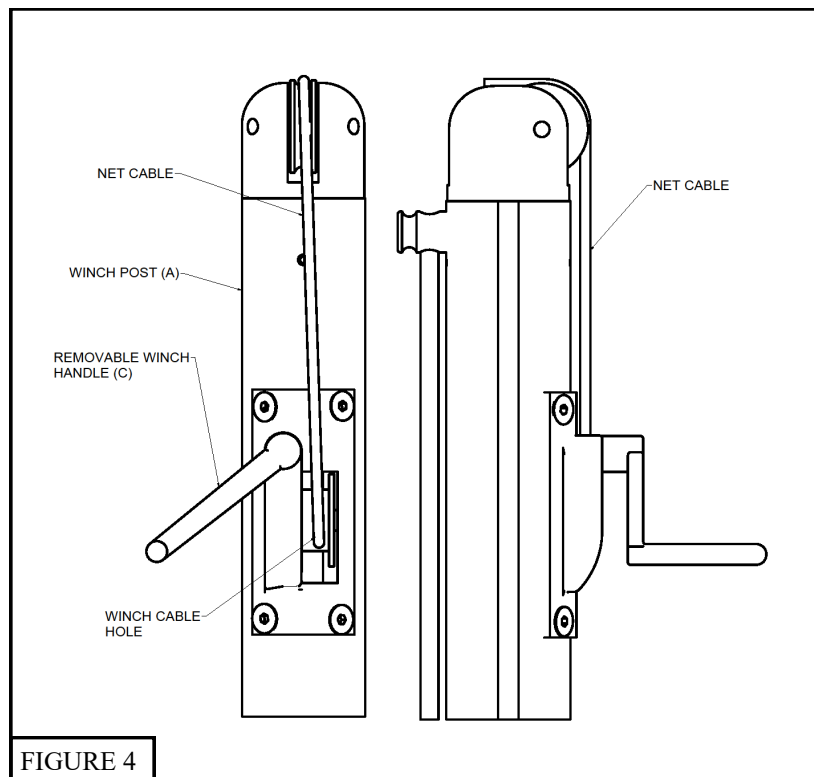
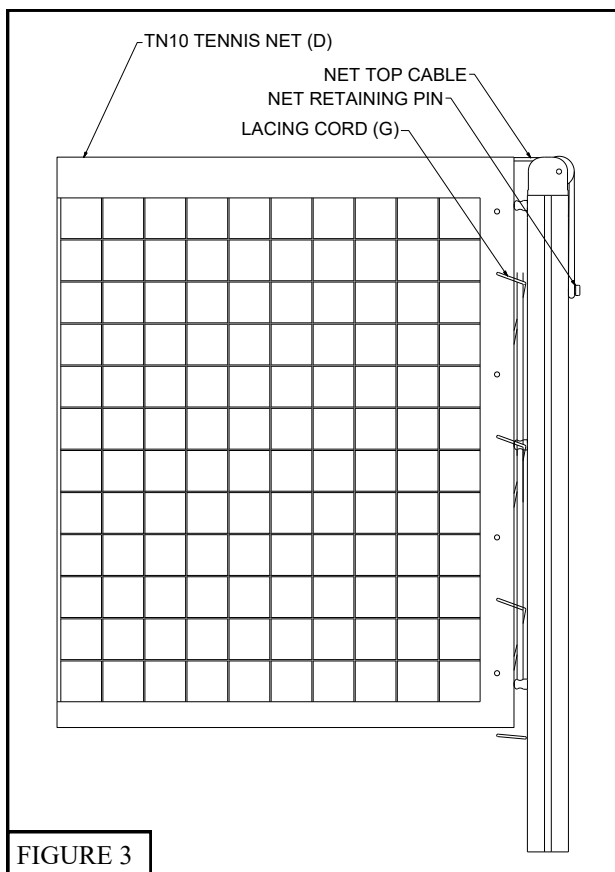

FIGURE 4

