

SIDE

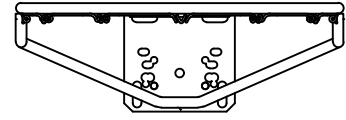

FRONT

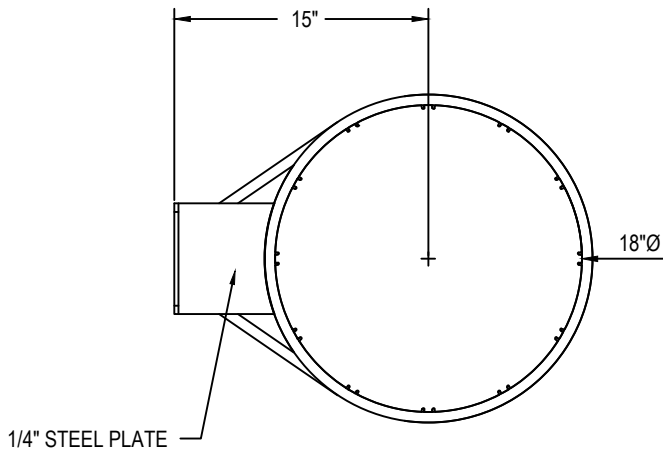

TOP

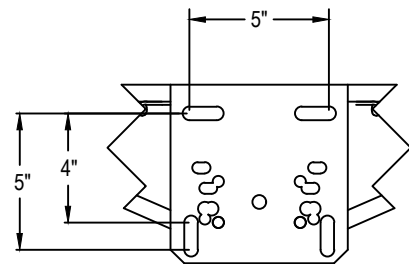

REAR (UNIVERSAL BACKPLATE)

Rim shall consist of an official size 5/8" diameter AISI 1018 cold drawn carbon steel ring welded to a 1/4" thick back plate punched to fit all common front mount backboards. A 5/8" diameter rim support shall support the ring. To be considered as an equal to this rim specification, an additional 6" long 5/8" diameter formed bar must be positioned at the bottom side of the joint between the back plate and the ring and welded full length on both sides. Mounting hardware shall be included. Installation to be completed in accordance with manufacturer's instructions. Do not scale drawings. Rim shall have continuous wire formed netlocks to accept nylon net (included), a 2-year limited warranty, orange powder coated finish, be made in the USA and weigh approximately 17#.



PRODUCT SPECIFICATION

BA27A FRONT MOUNT SUPER GOAL

REVISED 7/1/17