

# — Assembly Manual —



Customer Service  
(800) 247-7668

## BA165V/BA245V

### Lockable Vertical Ball Carts

PARTS LIST					
Item	Qty	Description	Item	Qty	Description
A	2	Cart End	G	4	Caster
B	2	Lock Plate	H	4	3/8" Lock Washer
C	2	3/8" X 2" Hex Bolt	I	12	Horizontal Bar (packaged separately)
D	1	3/8" X 1" Hex Bolt	J	24	1/2" Button Head Cap Screw
E	1	Nylon Spacer	K	1	5/16" Allen Wrench
F	7	3/8" Lock Nut			

- ◆ Inspect all contents prior to installation. Report any missing parts to dealer immediately.
  - ◆ Read all instructions before proceeding.
1. Assemble *Lock Plate* (B) to *Cart End* (A) using a *3/8" X 2" Hex Bolt* (C) through the center hole, the *Nylon Spacer* (E) between the *Lock Plate* (B) and the *Cart End* (A), and a *3/8" Lock Nut* (F). Tighten so the *Lock Plate* (B) can rotate easily but with some resistance so it stays in position when rotated. See Figure 1.
  2. Assemble *Lock Plate* (B) to *Cart End* (A) using a *3/8" X 2" Hex Bolt* (C) through the center hole and a *3/8" Lock Nut* (F), do not fully tighten. Rotate *Lock Plate* (B) so the "legs" are at a 45° angle in relation to the cross tubes on the *Cart End* (A). Secure the *Lock Plate* (B) in this position using a *3/8" X 1" Hex Bolt* (D) and a *3/8" Lock Nut* (F) through an aligned hole through the *Lock Plate* (B) and the *Cart End* (A), fully tighten hardware. Install the *Casters* (G) to this *Cart End* (A) using the *3/8" Lock Washers* (H) and *3/8" Lock Nuts* (F) making sure the *Lock Plate* (B) is facing up. See Figures 2 & 3.
  3. Assemble both *Cart Ends* (A) to the *Horizontal Bars* (I) using the *1/2" Button Head Cap Screws* (J) and the *5/16" Allen Wrench* (K). Make sure both *Lock Plates* (B) are facing up. See Figure 4.
  4. After assembling, tilt cart upright onto the *Casters* (G). To secure the ball cart, rotate the *Locking Plate* (B) and lock with a padlock (customer supplied). See Figure 5.

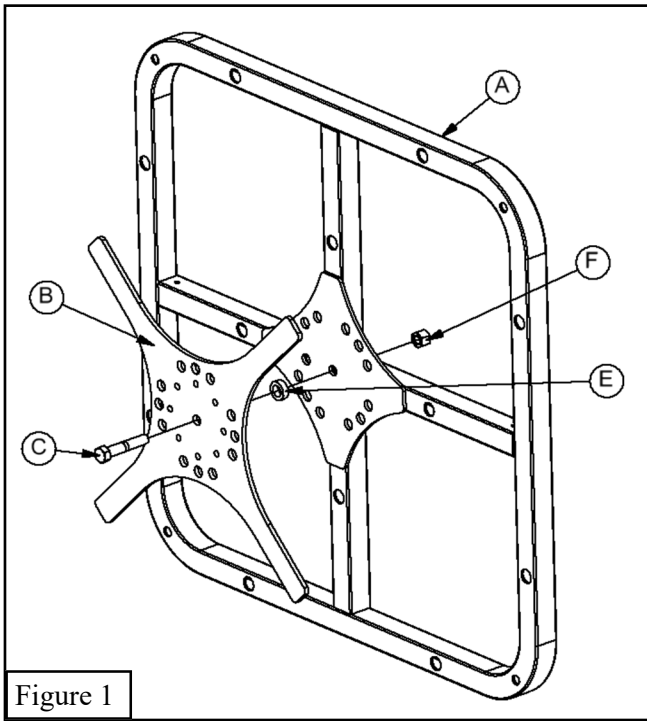

Figure 1

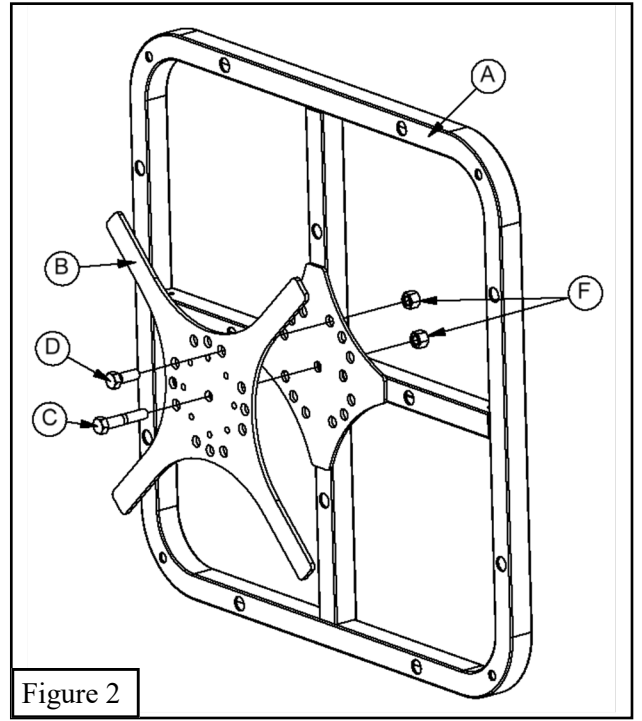

Figure 2

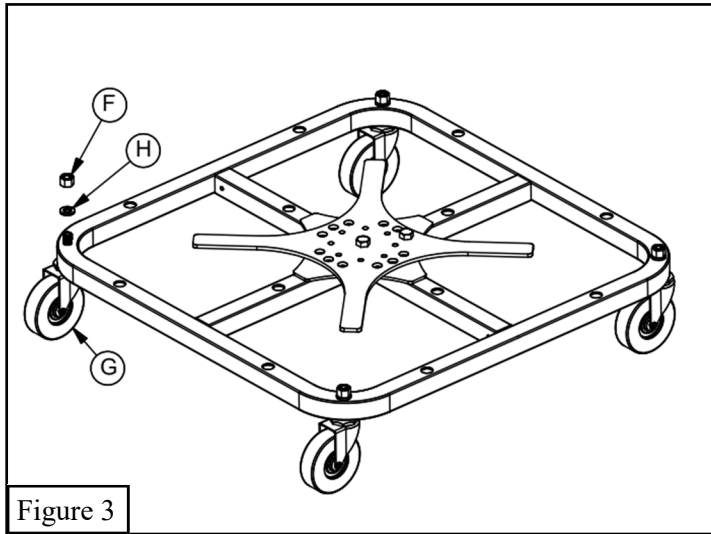

Figure 3

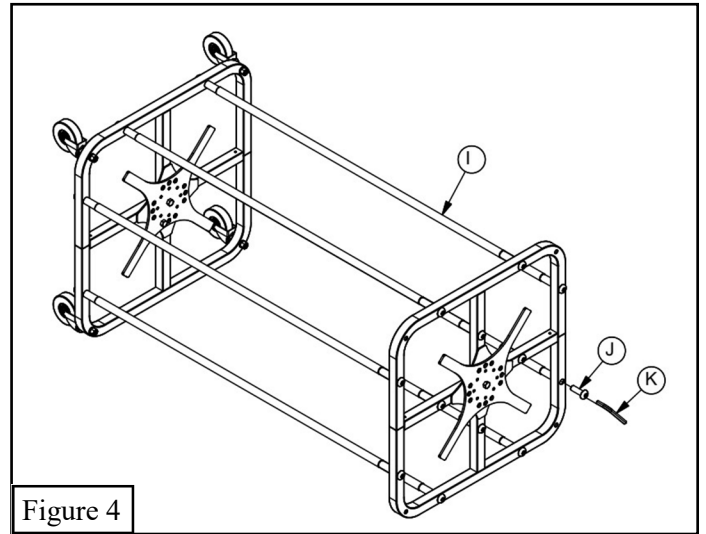

Figure 4

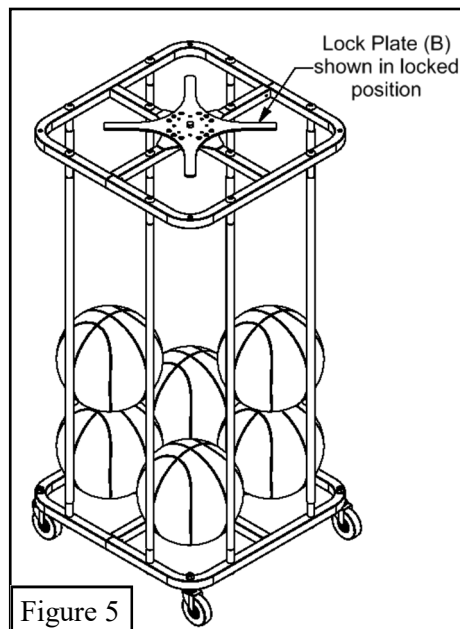

Figure 5