

OPERATOR'S MANUAL

IMPORTANT: Read this Owner's Manual Completely before attempting to use this equipment. Save this manual and keep it handy for quick reference. Pay particular attention to the safety instructions we have provided for your protection. Contact your distributor if you do not fully understand this manual.

AIR PLASMA CUTTER

SPARK 100 CNC



1 Safety.....	3
Important Safety Precautions.....	3
2 Technology Parameters	5
2.1 Parameters	5
3 Installation.....	6
3.1 Unpacking.....	6
3.2 Input Power Connections	6
3.3 Gas Connections.....	6
4 Operation.....	7
4.1 Layout Of The Front And Rear Panel	7
4.2 2 Function introduction.....	8
4.3 Cutting Preparation	11
4.4 Cutting Operation	12
4.5 Restore Factory Defaults	12
5 Maintenance.....	13
5.1 Cutting torch maintenance.....	13
5.2 Troubleshooting Principle.....	13
5.3 Electrical principle drawing	16
APPENDIX	17
6.1 About the CUT voltage divider	17

1 Safety

Important Safety Precautions



OPERATION AND MAINTENANCE OF PLASMA ARC EQUIPMENT CAN BE DANGEROUS AND HAZ- ARDOUS TO YOUR HEALTH.

Plasma arc cutting produces intense electric and magnetic emissions that may interfere with the proper function of cardiac pacemakers, hearing aids, or other electronic health equipment. Persons who work near plasma arc cutting applications should consult their medical health professional and the manufacturer of the health equipment to deter- mine whether a hazard exists.

To prevent possible injury, read, understand and follow all warnings, safety precautions and instructions before using the equipment.



GASES AND FUMES

Gases and fumes produced during the plasma cutting process can be dangerous and hazardous to your health.

- Keep all fumes and gases from the breathing area. Keep your head out of the cutting fume plume.
- Use an air-supplied respirator if ventilation is not adequate to remove all fumes and gases.
- The kinds of fumes and gases from the plasma arc depend on the kind of metal being used, coatings on the metal, and the different processes. You must be very careful when cutting or cutting any metals which may contain one or more of the following:

Antimony	Chromium	Mercury	Beryllium
Arsenic	Cobalt	Nickel	Lead
Barium	Copper	Selenium	Silver
Cadmium	Manganese	Vanadium	

Always read the Material Safety Data Sheets (MSDS) that should be supplied with the material you are using. These MSDSs will give you the information regarding the kind and amount of fumes and gases that may be dangerous to your health.

- Use special equipment, such as water or down draft cutting tables, to capture fumes and gases.
- Do not use the plasma torch in an area where combustible or explosive gases or materials are located.
- Phosgene, a toxic gas, is generated from the vapors of chlorinated solvents and cleansers. Remove all sources of these vapors.



ELECTRIC SHOCK

Electric Shock can injure or kill.

The plasma arc process uses and produces high voltage electrical energy. This electric energy can cause severe or fatal shock to the operator or others in the workplace.

- Never touch any parts that are electrically “live” or “hot.”
- Wear dry gloves and clothing. Insulate yourself from the work piece or other parts of the cutting circuit.
- Repair or replace all worn or damaged parts.
- Extra care must be taken when the workplace is moist or damp.
- Disconnect power source before performing any service or repairs.
- Read and follow all the instructions in the Operating Manual.



FIRE AND EXPLOSION

Fire and explosion can be caused by hot slag, sparks, or the plasma arc.

- Be sure there is no combustible or flammable material in the workplace. Any material that cannot be removed must be protected.
- Ventilate all flammable or explosive vapors from the workplace.
- Do not cut or weld on containers that may have held combustibles.
- Provide a fire watch when working in an area where fire hazards may exist.
- Hydrogen gas may be formed and trapped under aluminum workpieces when they are cut underwater or while using a water table. DO NOT cut aluminum alloys underwater or on a water table unless the hydrogen gas can be eliminated or dissipated. Trapped hydrogen gas that is ignited will cause an explosion.



NOISE

Noise can cause permanent hearing loss. Plasma arc processes can cause noise levels to exceed safe limits.

- You must protect your ears from loud noise to prevent permanent loss of hearing.
- To protect your hearing from loud noise, wear protective ear plugs and/or ear muffs. Protect others in the workplace.
- Noise levels should be measured to be sure the decibels (sound) do not exceed safe levels.



PLASMA ARC RAYS

Plasma Arc Rays can injure your eyes and burn your skin. The plasma arc process produces very bright ultra violet and infra-red light. These arc rays will damage your eyes and burn your skin if you are not properly protected.

- To protect your eyes, always wear a cutting helmet or shield. Also always wear safety glasses with side shields, goggles or other protective eye wear.
- Wear cutting gloves and suitable clothing to protect your skin from the arc rays and sparks.
- Keep helmet and safety glasses in good condition. Replace lenses when cracked, chipped or dirty.
- Protect others in the work area from the arc rays. Use protective booths, screens or shields.

2 Technology Parameters

2.1 Parameters

Models		Magic CUT 100E
Parameters		
Rated input voltage (V)		3-400V±15%, 50/60Hz
Rated input current (A)		28.7
Rated input power (KW)		13.8
Cutting current adjustment range (A)		20~100
Pilot current (A)		20
No-load voltage (V)		300
Duty cycle (40°C 10minutes)		60% 100A 120V
The max. cutting thickness to Carbon steel (mm)		50
Optimal cutting thickness (mm)	Carbon steel	≤45
	Stainless steel	≤35
	Aluminium	≤25
	Cuprum	≤20
Dimensions (mm)		470*250*200
Protection class		IP23S
Insulation class		F
Net weight (kg)		26.1
Cooling method		FAN

Note: The above parameters are subject to change with the improvement of machines.

3 Installation

3.1 Unpacking

1. Use the packing lists to identify and account for each item.
2. Inspect each item for possible shipping damage. If damage is evident, contact your distributor and / or shipping company before proceeding with the installation.

3.2 Input Power Connections

Note: Check your power source for correct voltage before plugging in or connecting the unit

3.3 Gas Connections

A. Connecting Gas Supply to Unit

Connect the gas line to the inlet port of the gas filter on the rear panel.

B. Check Air Quality

To test the quality of air, press on function button briefly, check if there are any oil or moisture in the air .

4 Operation

4.1 Layout Of The Front And Rear Panel

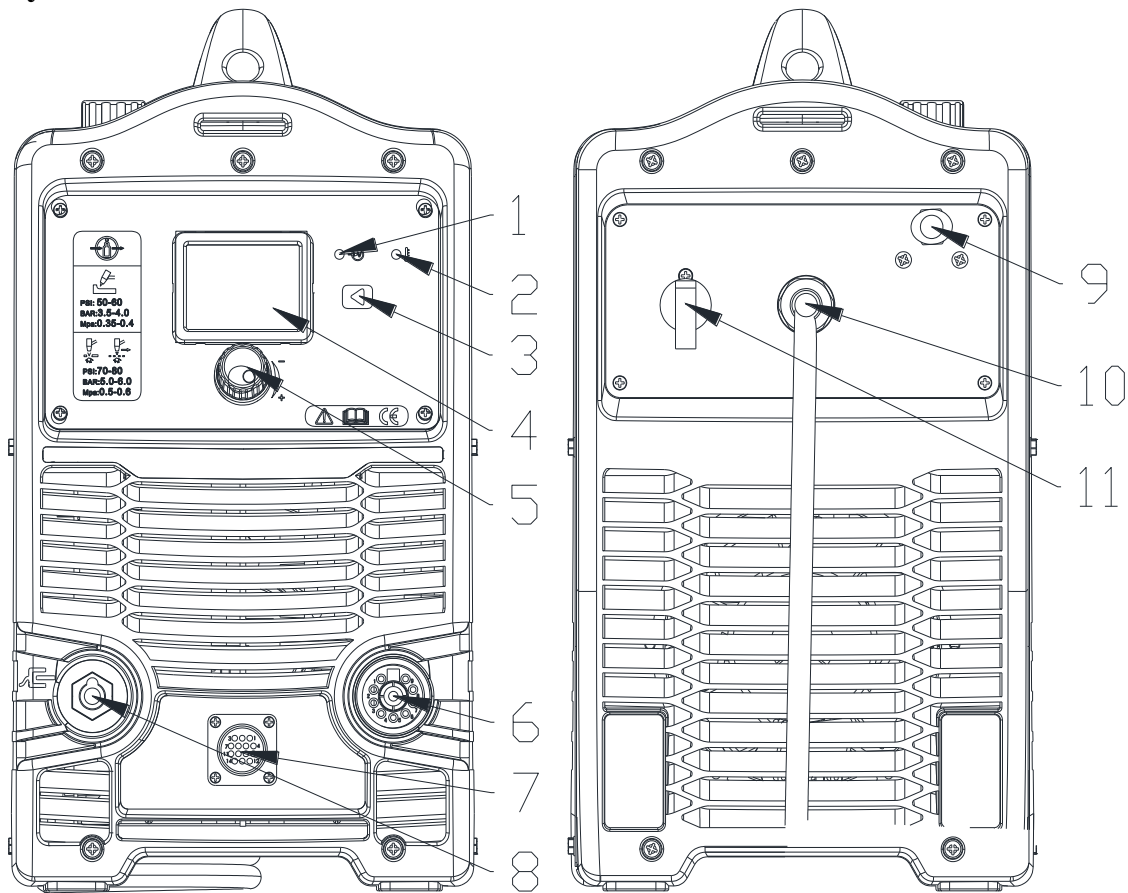

Figure 1.

1. **Power lamp** turn on power, the green lamp on
2. **Over-heat alarm** when over-heat, the yellow lamp would be on.
3. **Function button** select cutting mode, switch first and second menu.
4. **LCD** display machine status, such as the cutting current, air pressure, cutting mode, etc
5. **Encoder** adjust the cutting current and air pressure
6. **Cutting torch connector**
7. **Aviation connector**
8. **Positive output cable**
9. **Compressed air connector**
10. **Power cable** connected to the appreciate power supply
11. **Power switch** turn on or off the power source

4.2 2 Function introduction

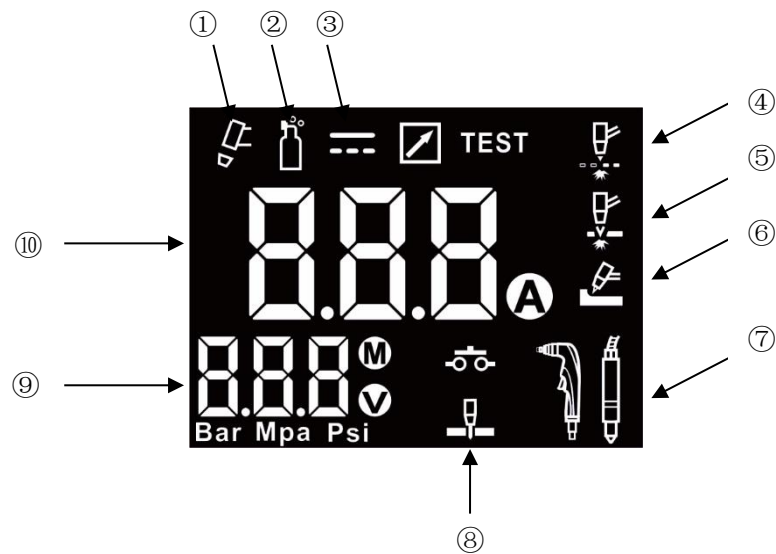
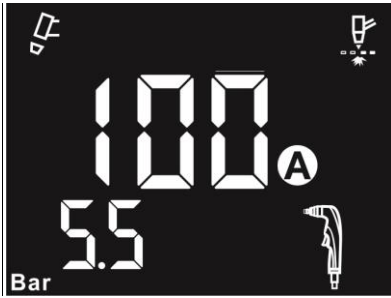

Figure 2.

- ① check whether the cutting torch is connected
- ② gas pressure lamp
- ③ the machine is in working condition
- ④ grid cutting mode
- ⑤ normal cutting mode
- ⑥ gouging/marking cutting mode
- ⑦ the types of the cutting torch
- ⑧ transfer arc player
- ⑨ cutting parameters which contains air pressure/output voltage/ the recommended length of the cutting torch
- ⑩ cutting current

Tips:The LCD contains two menus. In the first menu, the cutting current and the cutting mode can be adjusted. Hold down the function button for 1 second, the cutting parameters flashes, it is on the second menu this time. If there is no operation for 6 seconds, or hold down the function button for 1 second again, the cutting current display flashes, it will switch back to first menu.

1. Cutting mode selection



Grid cutting mode, use the encoder to adjust the cutting current, press on function button briefly to switch cutting mode. The current range is 20-100A, the air pressure range is 4.5-6.0Bar.

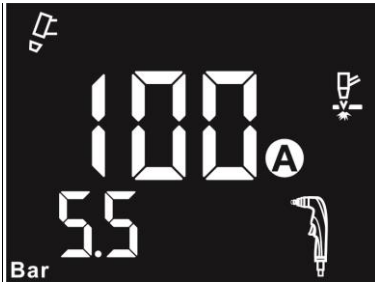

Normal cutting mode, use the encoder to adjust the cutting current, press on function button briefly to switch cutting mode. The current range is 20-100A, the air pressure range is 4.5-6.0Bar.

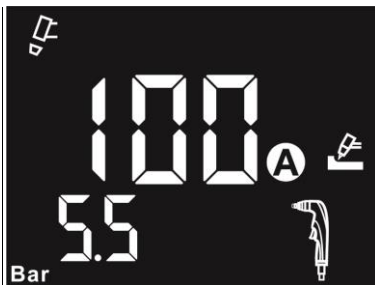

Gouging cutting mode, use the encoder to adjust the cutting current, press on function button briefly to switch operational mode. The current range is 20-100A, the air pressure range is 4.5-6.0Bar.

2. Cutting parameters(which contains air pressure/output voltage)

Hold down the function button for 1 second, the cutting parameters flashes. Press on function button briefly to set Bar, Mpa or Psi. Continue to press on function button briefly, the output voltage will display, as shown in the Figure.



Figure 3.

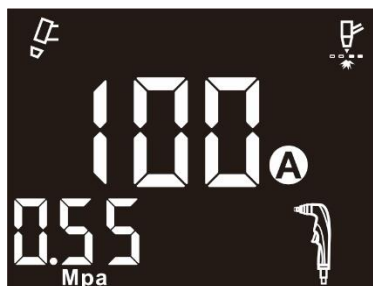

Figure 4.



Figure 5.

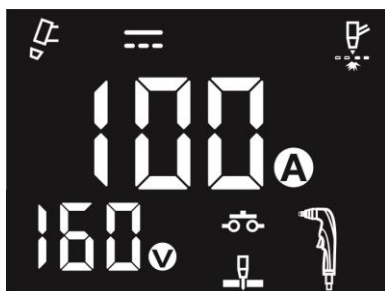

Figure 6.

3. Two different kinds of cutting torch

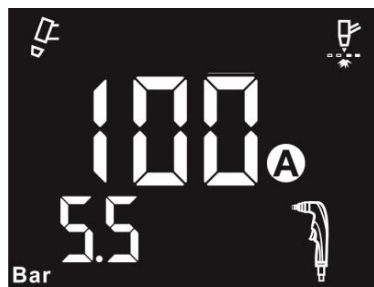

Figure 7.



Figure 8.

Figure 7 shown is the manual cutting torch, and the Figure 8 shown is the machine cutting torch.

4. Alarm display



Figure 9.



Figure 10.

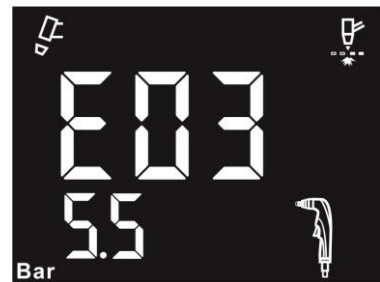

Figure 11.



Figure 12.



Figure 13.

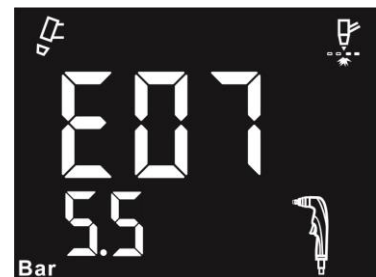

Figure 14.



Figure 15.



Figure 16.



Figure 17.



Figure 18.



Figure 19.

Light	Condition	Display	Status/Possible Cause
		E01	Over-Current. Check output diodes, main transformer and IGBT on the invert board.
Temp	On	E02	Over-Temperature. Stop cutting for cooling..
		E03	No system is established. Check consumables or torch.
Nozzle	Repetive flashing rate of one quick circles, then a one second pause for a 15 second period or until torch trigger is pressed again, whichever comes first	E04	No pilot arc established possibly due to a loss of current. Check consumables.
Nozzle	Repetive flashing rate of three quick circles, then a one second pause for a 15 second period or until torch trigger is pressed again, whichever comes first.	E05	Consumables in torch failed to separate during pilot arc possibly due to being stuck. Check consumables.
		E07	Input power is over 460V AC. Check input power.
		E08	Input power is below 340V AC. Check input power
		E09	Input power lacks phase. Check input power
Cup & Nozzle		E11	Low (below 2.1 Bar) output pressure or no input pressure.
Pressure	on	E13	Torch cup is loose or off.
		E14	Torch trigger is pressed before starting or during initialization. If trigger is pressed during the first second, the machine needs to restart. If trigger is pressed during the last three seconds, a 15 second period or until torch trigger is pressed again, whichever comes first.

4.3 Cutting Preparation

- 1、Tightly connect the power cable to electrical socket outlet (the input voltage, refer to the section 2 technology parameters)
- 2、connect the air pipe to the air supply equipment, the earth cable to the workpiece.
- 3、turn on the power switch, the power source lamp on, the machine will check automatically.
- 4、regulate the current after the pre-gas stops.
- 5、now all the preparation done.

4.4 Cutting Operation

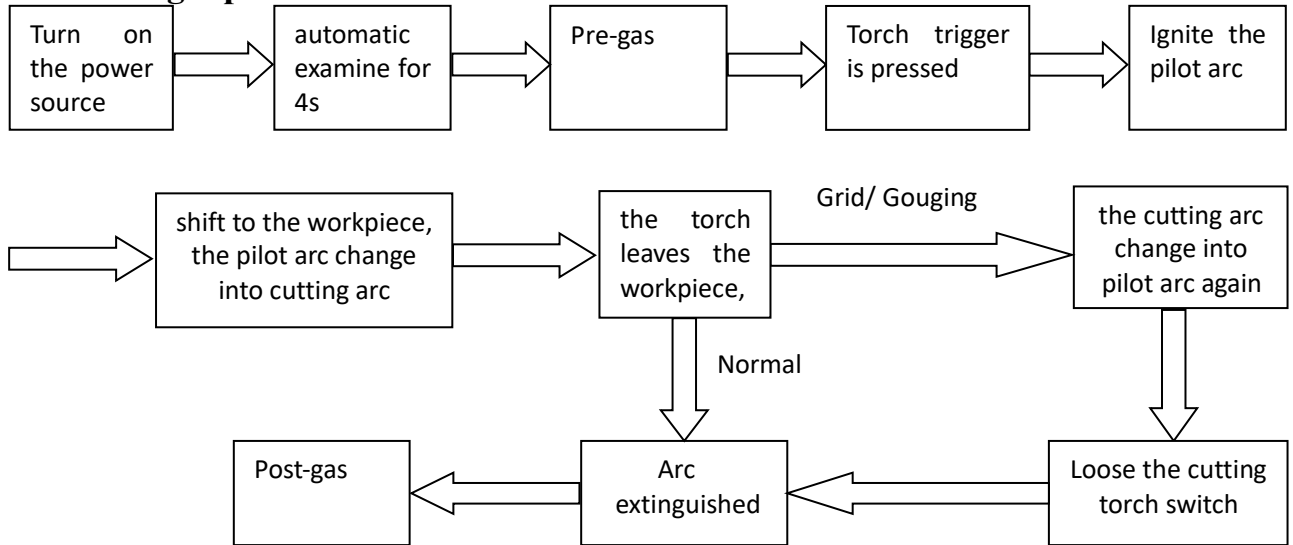

- Note:
- (1) The alarm lamp on when cutting, it is needed to loose the trigger of the torch until the alarm release, then press on the trigger to start cutting again.
 - (2) In the pre-gas and examine, if the torch trigger is pressed, E14 will display.
 - (3) After a long usage, the surface of the electrode and nozzle will have Oxidation reaction. Please replace the electrode and nozzle. The alarm lamp will on when install the shield cup, and stop working.

4.5 Restore Factory Defaults

Press the function button to turn it on, and the time will exceed 2S, the machine will be restored to the factory settings. The cutting current is 100A, the cutting mode is normal cutting mode, and the barometric pressure is Bar.

5 Maintenance

5.1 Cutting torch maintenance

Warning :

1. Check the consumable parts for damage, if worn, replace it.
2. Turn off the power source before check or remove cutting torch parts.

Note: When operating the torch in a normal condition, a small amount of gas vents through the gap between the shield cup and the torch handle, Do not attempt to over tighten the shield cup as irreparable damage to internal components may result.



Socket

1. Torch switch.
2. Common.
3. Machine/Manual torch.
5. Pilot arc cable.
6. Pilot arc.
8. Common.
9. Torch shield cable.

Function	Connection method
Torch switch	1.2
Pilot arc	5.6
Torch shield	8.9

5.2 Troubleshooting Principle



WARNING

There are extremely dangerous voltage and power levels present inside this unit. Do not attempt to diagnose or repair unless you have had training in power electronics measurement and troubleshooting techniques.

A. Temperature lamp on.

1. Fan blocked, check and correct condition.
2. Unit is overheated, let unit cool down for at least 5 minutes. Make sure the unit has not been operated beyond Duty Cycle limit, refer to technology parameters in Section 2.
3. Faulty components in unit, return for repair or have qualified technician repair per Service Manual.

B. Torch fails to ignite the arc when torch trigger is depressed

1. Faulty torch parts, inspect torch parts and replace if necessary.
2. Gas pressure too low, adjust to proper pressure.
3. Faulty components in unit, return for repair or have qualified technician repair per Service Manual.

C. No cutting output; Torch activated, power source on; Gas flows; Fan operates

1. Torch not properly connected to power supply, check that torch leads are properly connected to power supply.
2. Work cable not connected to work piece, or connection is poor, make sure that work cable has a proper connection to a clean, dry area of the workpiece.
3. Faulty components in unit, return for repair or have qualified technician repair per Service Manual.
4. Faulty Torch, return for repair or have qualified technician repair.

D. Low cutting output

1. Incorrect setting of CURRENT (A) control, check and adjust to proper setting.
2. Faulty components in unit, return for repair or have qualified technician repair.

E. Difficult Starting

1. Worn torch parts (consumables), shut off input power. Remove and inspect torch shield cup, tip and electrode. Replace electrode or tip if worn; replace shield cup if excessive spatter adheres to it.

F. Arc shuts off during operation; arc will not restart when torch switch is activated

1. Power Supply is overheated (OT lamp on), let unit cool down for at least 5 minutes. Make sure the unit has not been operated beyond Duty Cycle limit. Refer to Section 2 for duty cycle specifications.
2. Gas pressure is out of range; adjust as needed.
3. Torch consumables worn, check torch shield cup, tip, starter element, and electrode; replace as needed.
4. Faulty components in unit; return for repair or have qualified technician repair per Service Manual.

G. No gas flow; the power lamp on; Fan operates

1. Gas not connected or pressure too low, check gas connections. Adjust gas pressure to proper setting.
2. Faulty components in unit, return for repair or have qualified technician repair.

H. Torch cuts but low quality

1. Current (A) control set too low, increase current setting.
2. Torch is being moved too fast across workpiece, reduce cutting speed.
3. Excessive oil or moisture in torch, hold torch 1/8 inch (3 mm) from clean surface while purging and observe oil or moisture buildup (do not activate torch). If there are contaminants in the gas, additional filtering may be needed.

APPENDIX

6.1 About the CUT voltage divider

The CUT power supplies are equipped with an optional, factory-installed, four-position voltage divider that is designed to be safely connected without tools. The built-in voltage divider provides a scaled down arc voltage of 20:1, 21.1:1, 30:1, 40:1, and 50:1 (maximum output of 18 V). An optional receptacle on the rear of the power supply provides access to the scaled down arc voltage and signals for arc transfer and plasma start.

Note:

The factory presets the voltage divider to 50:1. To change the voltage divider to a different setting, refer to the section on the next page.

	<p>The factory-installed internal voltage divider provides a maximum of 18 V under open circuit conditions. This is an impedance-protected functional extra low voltage (ELV) output to prevent shock, energy, and fire under normal conditions at the machine interface receptacle and under single fault conditions with the machine interface wiring. The voltage divider is not fault tolerant and ELV outputs do not comply with safety extra low voltage (SELV) requirements for direct connection to computer products.</p>
---	---

Note:

The cover on the machine interface receptacle prevents dust and moisture from damaging the receptacle when not in use. This cover should be replaced if damaged or lost.

Installation of the machine interface cable must be performed by a qualified service technician. To install a machine interface cable:

1. Turn OFF the power and disconnect the power cord.
2. Remove the machine interface receptacle's cover from the front of the power supply.
3. Connect the Pritec machine interface cable to the power supply.

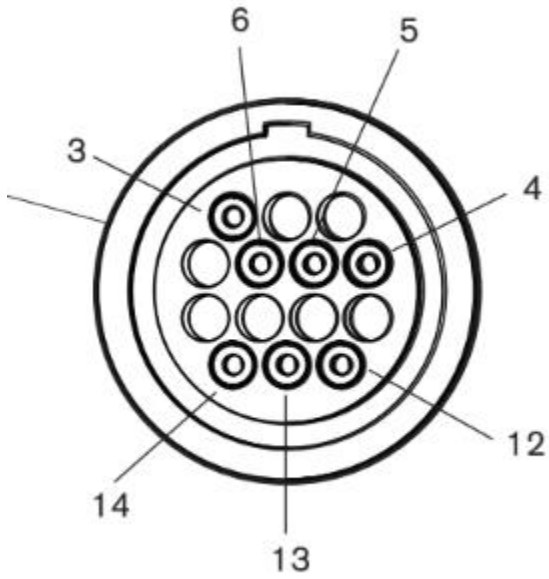

Refer to the following table when connecting the CUT system to a torch height controller or CNC controller with a machine interface cable.

signal	type	Instruction	The connector socket	Cable ends
Start (start plasma)	Input	Normally open. 18 VDC open circuit voltage at START terminals. Requires dry contact closure to activate.	3, 4	3 (yellow) 、 4 (yellow)
Transfer(start machine motion)	Output	Normally open. Dry contact closure when the arc transfers. 120 VAC/1 A maximum at the machine interface relay or switching device (supplied by the customer).	12、 14	12 (white) 、 14 (white)
Ground	Ground		13	
Voltage divider	Output	CUT: Divided arc signal of 20:1, 21.1:1, 30:1, 40:1, 50:1 (provides a maximum of 18 V).	5 (-) 、 6 (+)	5 (white) 、 6 (red)

Setting the five-position voltage divider on the CUT

The factory presets the voltage divider to 50:1. To change the voltage divider to a different setting:



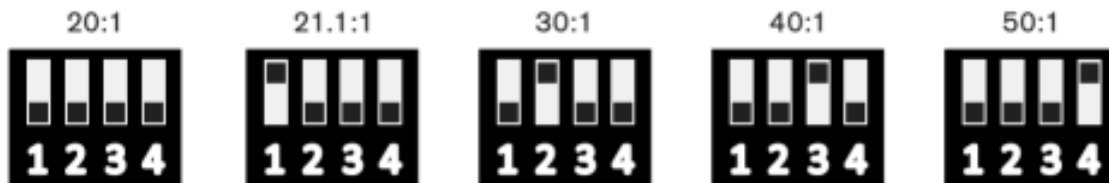

1. Turn OFF the power supply and disconnect the power cord.
2. Remove the power supply cover.
3. Locate the voltage divider DIP switches on the left side of the power supply.

Note: the table below for the shift and scale selection

scale selection dial number	20:1	21.1:1	30:1	40:1	50:1
1	OFF	ON	OFF	OFF	OFF
2	OFF	OFF	ON	OFF	OFF
3	OFF	OFF	OFF	ON	OFF
4	OFF	OFF	OFF	OFF	ON

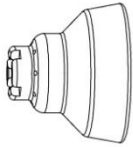

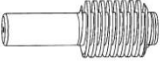
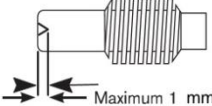
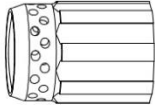
Inspect the consumables

Part	Inspect	Action
 <p>Shield or deflector</p>	<p>The center hole for roundness. The gap between the shield and the nozzle for accumulated debris.</p>	<p>Replace the shield if the hole is no longer round. Remove the shield and clean any material away.</p>
 <p>Nozzle</p>	<p>The center hole for roundness.</p>  <p>Good Worn</p>	<p>Replace if the center hole is not round. Replace the nozzle and the electrode together.</p>
 <p>Electrode</p>	<p>The center surface for wear and verify the pit depth.</p>  <p>Maximum 1 mm</p>	<p>Replace if the surface is worn or the pit depth is greater than 1 mm deep. Replace the nozzle and the electrode together.</p>
 <p>Swirl ring</p>	<p>The internal surface for damage or wear and the gas holes for blockages.</p>	<p>Replace if the surface is damaged or worn or any of the gas holes are blocked.</p>
 <p>Torch o-ring</p>	<p>The surface for damage, wear, or a lack of lubrication.</p>	<p>If the o-ring is dry, lubricate it and the threads with a thin layer of silicone lubricant. If the o-ring is cracked or worn, replace it.</p>