

ITEM NO.	QTY.	PART NUMBER	DESCRIPTION	Material
1	1	2434-3001	COVER: 1524K	356.2-F
2	1	0011-2002	HUB, AL, 4 HOLE	535-F
3	4	0211-2004	DOG, LOCKING ARM 1524, AL	535-F
4	4	0413-2005	WASHER, .406X1.25X.062 NYLON	PTFE (general)
5	4	0411-2033	WASHER .406 X 1.25 X .125IN SS 316	316/316L
6	4	0411-2032	NUT, HEX .375-16 SS 316 NYLOCK	316/316L
7	1	0021-2005	HANDLE, S/S, ROUND BAR	BAR, SS 316L .75IN DIA ROUND (0613-9521)
8	1	0411-2004	PIN, KNURLED .25 DIA X 2.25IN SS 316	316/316L
9	1	0112-2001	ACTUATOR, AL	535-F
10	1	9835-2008	GASKET, 1524K (5.58' OF 0631-9835)	Rubber
11	1	0031-2058	BUSHING ASSY, W/O-RING NO SLEEVE	REF S.A. BOM
12	1	0435-2136	MOUNT, SENSOR, CAST HATCH	6061-T6/T651
13	1	0411-2110	SCREW, SET A 8-32X.188IN CUP PT SS 316	SS 316/316L
14	1	0437-2026	SENSOR MAGNET, PROXIMITY	(SENSOR MAGNET, CYL PROXIMITY 1000 WHT)

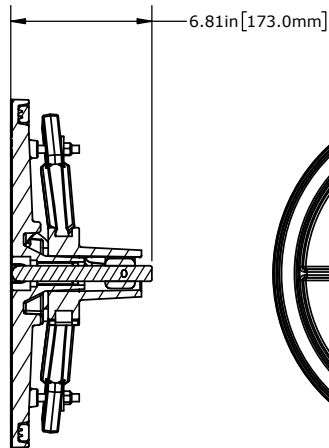

SECTION A-A  
SCALE 1 : 6

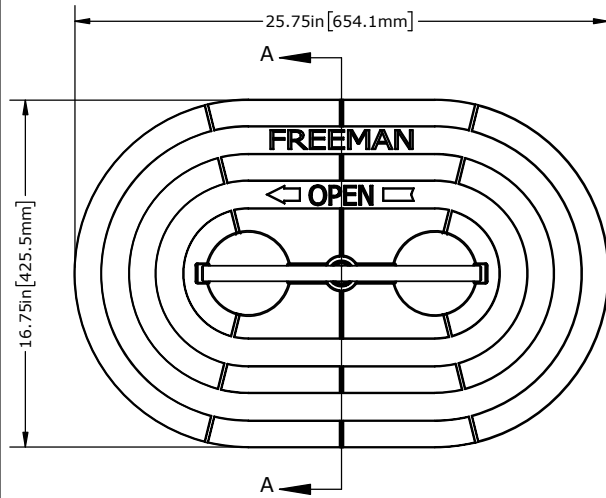
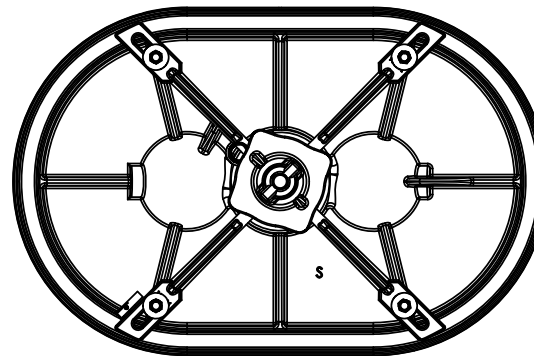

**REVISIONS**

REV.	DESCRIPTION	BY	DATE

**GENERAL NOTES**

1. ALL DIMENSIONS SHOWN SUBJECT TO CASTING VARIATION AND ARE REFERENCE ONLY.
2. QUICK-ACTING, MECHANISM ENGAGES OR DISENGAGES IN QUARTER-TURN OF CENTER SPINDLE.
3. APPROXIMATE WEIGHT: 11.23kg (24.75lb)
4. FINISH: COVER-BARE, NO PAINT/PRIMER.

FOR ADDITIONAL INFORMATION CONTACT YOUR SALES REPRESENTATIVE OR PROJECT MANAGER.

SHEETS AFTER SHEET 2 ARE USED FOR PRODUCTION.

**CUSTOMER APPROVAL**

IMPORTANT! THIS DRAWING SUPERSEDES ALL OTHER DOCUMENTS. BY SIGNING THIS APPROVAL YOU ACCEPT AND AGREE THAT THE DIMENSIONS AND DETAILS SHOWN ARE CORRECT AND PROPERLY FIT YOUR APPLICATION, REGARDLESS OF ANY DIFFERENCES BETWEEN THIS DRAWING AND ANY PRIOR CONTRACT SPECIFICATIONS. SHOULD YOU HAVE ANY QUESTIONS OR SEE ANY ERRORS, DO NOT SIGN THIS APPROVAL UNTIL THE DRAWING IS CORRECTED.

SIGN \_\_\_\_\_ DATE \_\_\_\_\_

UNLESS OTHERWISE SPECIFIED, DIMENSIONS ARE IN MILLIMETERS. TOLERANCES FOR ROUGH AND CLEAR OPENINGS ARE ±3mm (.125"). ALL OTHERS ARE:

METRIC	X	.X	.XX	ANGLES
	±2.5	±.8	±.25	±2°
IMPERIAL	.X	.XX	.XXX	ANGLES
	±.1	±.03	±.010	±2°

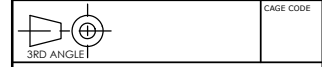

COPYRIGHT 2016 ADVANTEC GLOBAL INNOVATIONS. ALL RIGHTS RESERVED. CONFIDENTIAL PROPERTY OF ADVANTEC GLOBAL INNOVATIONS. UNAUTHORIZED USE, REPRODUCTION OR DISTRIBUTION IS STRICTLY PROHIBITED. COPIES REMAIN THE PROPERTY OF ADVANTEC GLOBAL INNOVATIONS AND MUST BE RETURNED UPON REQUEST.

CLIENT  
**FREEMAN MARINE**

PROJECT TITLE  
**STANDARD HATCH CPA**

DWG TITLE  
**HATCH, 1524 COVER**

SCALE	DRAWN	DATE	CHECKED	DATE	SIZE
1:8	DR	03/30/2023	10/30/2023		B

S.O. NO.	DWG NO.	SHEET	REV
	2434-1001	1	
		1	