

ITEM NO.	QTY.	PART NUMBER	DESCRIPTION	Material
1	1	0011-2002	HUB, AL, 4 HOLE	535-F
2	4	0211-2004	DOG, LOCKING ARM 1524, AL	535-F
3	4	0413-2005	WASHER, .406X1.25X.062 NYLON	PTFE (general)
4	4	0411-2033	WASHER .406 X 1.25 X .125IN SS 316	316/316L
5	4	0411-2032	NUT, HEX .375-16 SS 316 NYLOCK	316/316L
6	1	0021-2005	HANDLE, S/S, ROUND BAR	BAR, SS 316L .75IN DIA ROUND (0613-9521)
7	1	0411-2004	PIN, KNURLED .25 DIA X 2.25IN SS 316	316/316L
8	1	0112-2001	ACTUATOR, AL	535-F
9	1	9801-2005	GASKET: 1524 (5.58 FT. OF 0631-9801)	Rubber
10	1	0031-2058	BUSHING ASSY, W/O-RING NO SLEEVE	REF S.A. BOM
11	1	2433-3001 COVER ASSEMBLY	COVER: 1524	A356.0-F

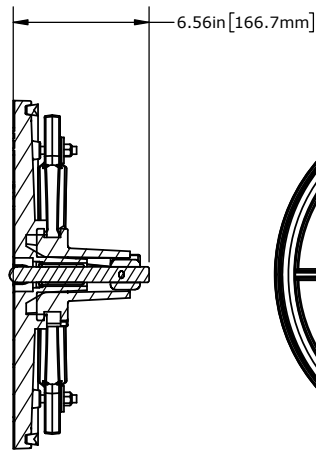

SECTION B-B  
SCALE 1 : 6

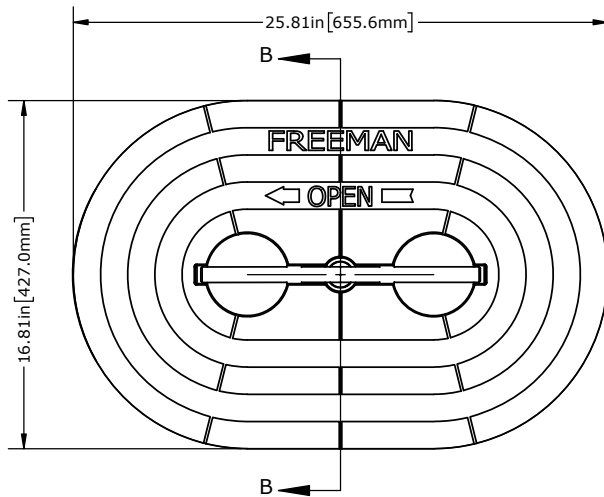
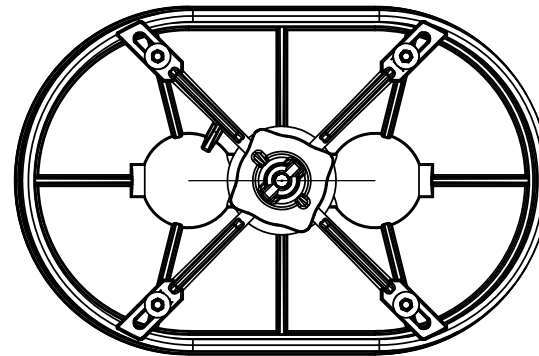

**REVISIONS**

REV.	DESCRIPTION	BY	DATE

**GENERAL NOTES**

1. ALL DIMENSIONS SHOWN SUBJECT TO CASTING VARIATION AND ARE REFERENCE ONLY.
2. QUICK ACTING, MECHANISM ENGAGES OR DISENGAGES IN QUARTER TURN OF CENTER SPINDLE.
3. APPROX WEIGHT 11.54kg (25.44lb)
4. FINISH: COVER-BARE, NO PAINT/PRIMER.

FOR ADDITIONAL INFORMATION CONTACT YOUR SALES REPRESENTATIVE OR PROJECT MANAGER.

SHEETS AFTER SHEET 2 ARE USED FOR PRODUCTION.

**CUSTOMER APPROVAL**

IMPORTANT! THIS DRAWING SUPERSEDES ALL OTHER DOCUMENTS. BY SIGNING THIS APPROVAL YOU ACCEPT AND AGREE THAT THE DIMENSIONS AND DETAILS SHOWN ARE CORRECT AND PROPERLY FIT YOUR APPLICATION, REGARDLESS OF ANY DIFFERENCES BETWEEN THIS DRAWING AND ANY PRIOR CONTRACT SPECIFICATIONS. SHOULD YOU HAVE ANY QUESTIONS OR SEE ANY ERRORS, DO NOT SIGN THIS APPROVAL UNTIL THE DRAWING IS CORRECTED.

SIGN \_\_\_\_\_ DATE \_\_\_\_\_

UNLESS OTHERWISE SPECIFIED, DIMENSIONS ARE IN MILLIMETERS. TOLERANCES FOR ROUGH AND CLEAR OPENINGS ARE ±3mm (.125"). ALL OTHERS ARE:

METRIC	X	.X	.XX	ANGLES
	±2.5	±.8	±.25	±2°
IMPERIAL	.X	.XX	.XXX	ANGLES
	±.1	±.03	±.010	±2°

	CAGE CODE
	64747



COPYRIGHT 2016 ADVANTEC GLOBAL INNOVATIONS. ALL RIGHTS RESERVED. CONFIDENTIAL PROPERTY OF ADVANTEC GLOBAL INNOVATIONS. UNAUTHORIZED USE, REPRODUCTION OR DISTRIBUTION IS STRICTLY PROHIBITED. COPIES REMAIN THE PROPERTY OF ADVANTEC GLOBAL INNOVATIONS AND MUST BE RETURNED UPON REQUEST.

CLIENT

FREEMAN MARINE

PROJECT TITLE  
STANDARD HATCH CPA

DWG TITLE  
HATCH, 2433 COVER

SCALE	DRAWN	DATE	CHECKED	DATE	SIZE
1:8	DR	10/30/2023			B

S.O. NO.	DWG NO.	SHEET	REV
	2433-1001	1	B
		1	