

ITEM	QTY	PART NUMBER	DESCRIPTION	MATERIAL
1	1	0011-2002	HUB, AL, 4 HOLE	535-F
2	1	0021-2005	HANDLE, S/S, ROUND BAR	BAR, SS 316L .75IN DIA ROUND (0613-9521)
3	1	0031-2058	BUSHING ASSY, W/O-RING NO SLEEVE	REF S.A. BOM
4	1	0112-2001	ACTUATOR, AL	535-F
5	4	0211-2008	DOG, LOCKING ARM 20, AL	535-F
6	1	0411-2004	PIN, KNURLED .25 DIA X 2.25IN SS 316	316/316L
7	4	0411-2032	NUT, HEX .375-16 SS 316 NYLOCK	316/316L
8	4	0411-2033	WASHER .406 X 1.25 X .125IN SS 316	316/316L
9	4	0413-2005	WASHER, .406X1.25X.062 NYLON	PTFE (general)
10	1	0441-2010	SLEEVE, HATCH FLUTED BUSHING SS 304 2.0	TUBING, W&BR 1.125 ODX.065 WALL SS 304(0441-2007)
11	1	2406-3001	COVER: 20 ALUM, FINISHED CASTING	A356-F
12	1	9801-2007	GASKET, 20 - 5.48FT 0631-9801	GASKET, DIE #207 50 DURO NEOPRENE (0631-9801)

REVISIONS			
REV.	DESCRIPTION	BY	DATE
00	PRODUCTION RELEASE	GB	5/30/2023

- GENERAL NOTES**
1. ALL DIMENSIONS SHOWN SUBJECT TO CASTING VARIATION AND ARE REFERENCE ONLY.
 2. QUICK-ACTING, MECHANISM ENGAGES OR DISENGAGES IN QUARTER-TURN OF CENTER SPINDLE.
 3. APPROX WEIGHT: 11.6 kg (25.5 lb).
 4. FINISH: COVER-BARE, NO PAINT/PRIMER.

FOR ADDITIONAL INFORMATION CONTACT YOUR SALES REPRESENTATIVE OR PROJECT MANAGER.

CUSTOMER APPROVAL
 IMPORTANT! THIS DRAWING SUPERSEDES ALL OTHER DOCUMENTS. BY SIGNING THIS APPROVAL YOU ACCEPT AND AGREE THAT THE DIMENSIONS AND DETAILS SHOWN ARE CORRECT AND PROPERLY FIT YOUR APPLICATION, REGARDLESS OF ANY DIFFERENCES BETWEEN THIS DRAWING AND ANY PRIOR CONTRACT SPECIFICATIONS. SHOULD YOU HAVE ANY QUESTIONS OR SEE ANY ERRORS, DO NOT SIGN THIS APPROVAL UNTIL THE DRAWING IS CORRECTED.

SIGN _____ DATE _____

UNLESS OTHERWISE SPECIFIED, DIMENSIONS ARE IN MILLIMETERS. TOLERANCES FOR ROUGH AND CLEAR OPENINGS ARE ±3mm (.125"). ALL OTHERS ARE:

METRIC	X	.X	.XX	ANGLES
	±2.5	±.8	±.25	±2°
IMPERIAL	.X	.XX	.XXX	ANGLES
	±.1	±.03	±.010	±2°

 3RD ANGLE
 CAGE CODE
 64747



COPYRIGHT 2016 ADVANTEC GLOBAL INNOVATIONS. ALL RIGHTS RESERVED. CONFIDENTIAL PROPERTY OF ADVANTEC GLOBAL INNOVATIONS. UNAUTHORIZED USE, REPRODUCTION OR DISTRIBUTION IS STRICTLY PROHIBITED. COPIES REMAIN THE PROPERTY OF ADVANTEC GLOBAL INNOVATIONS AND MUST BE RETURNED UPON REQUEST.

CLIENT
FREEMAN MARINE

PROJECT TITLE
STANDARD HATCH CPA

DWG TITLE
HATCH, 20 AL COVER

SCALE	DRAWN	DATE	CHECKED	DATE	SIZE
1:5	GB	5/30/2023			B

S.O. NO	DWG NO	SHEET	REV
	2406-1001	1 of 1	00

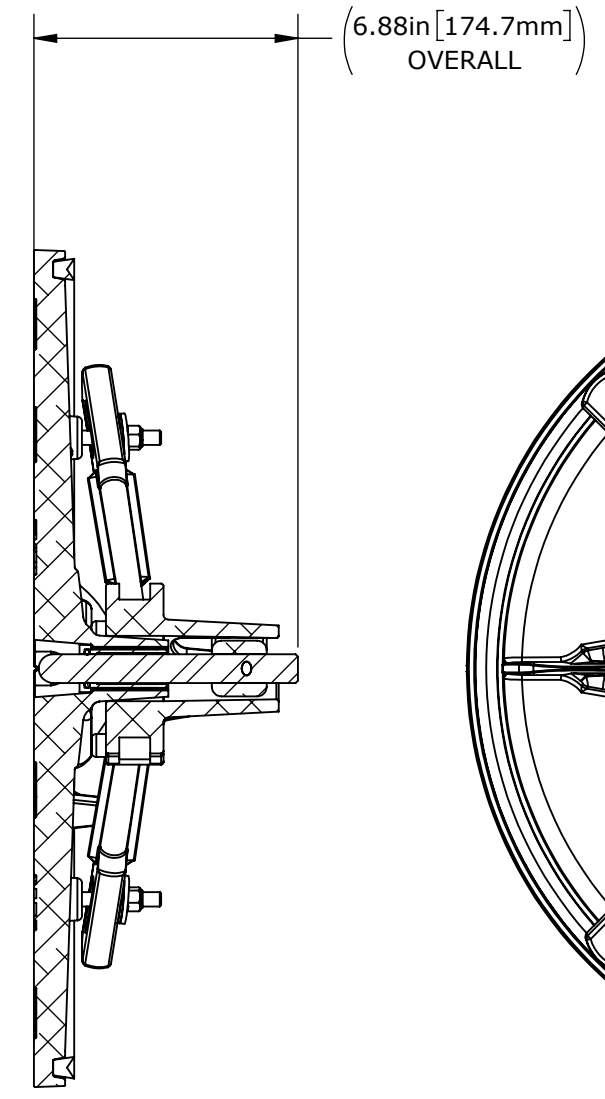
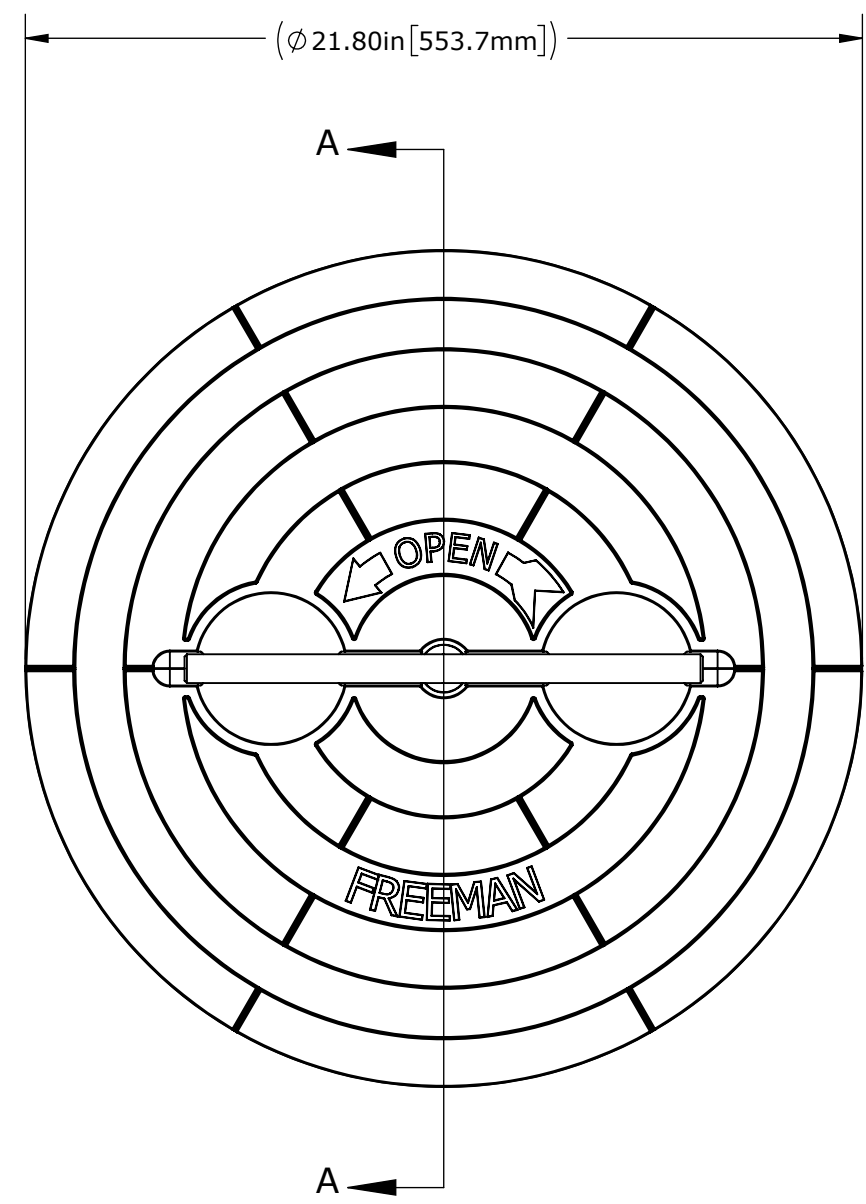

SECTION A-A

