

ITEM	QTY	PART NUMBER	DESCRIPTION	MATERIAL
1	1	0011-2001	HUB, 3 HOLE	535-F
2	1	0021-2005	HANDLE, S/S, ROUND BAR	BAR, SS 316L .75IN DIA ROUND (0613-9521)
3	1	0112-2001	ACTUATOR, AL	535-F
4	3	0211-2003	DOG, LOCKING ARM 15 AL	535-F
5	1	0411-2004	PIN, KNURLED .25 DIA X 2.25IN SS 316	316/316L
6	3	0411-2032	NUT, HEX .375-16 SS 316 NYLOCK	316/316L
7	3	0411-2033	WASHER .406 X 1.25 X .125IN SS 316	316/316L
8	3	0413-2005	WASHER, .406X1.25X.062 NYLON	PTFE (general)
9	1	2403-3001	COVER: 15 ROUND	A356-F
10	1	9801-2004	GASKET, 15 - 4.17FT (0631-9801)	GASKET, DIE #207 50 DURO NEOPRENE (0631-9801)

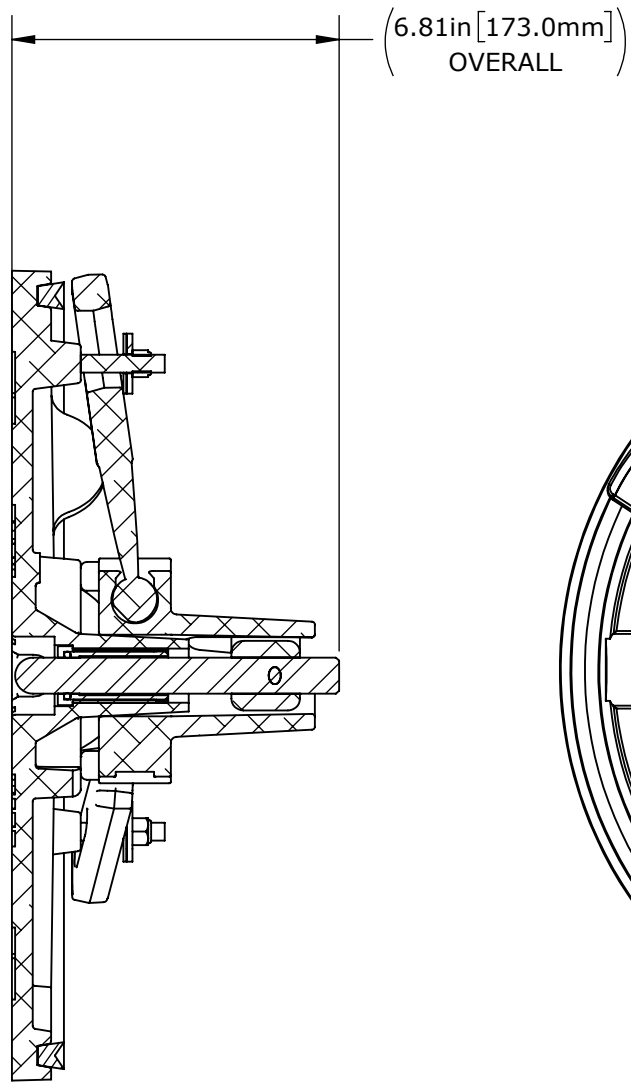

SECTION A-A

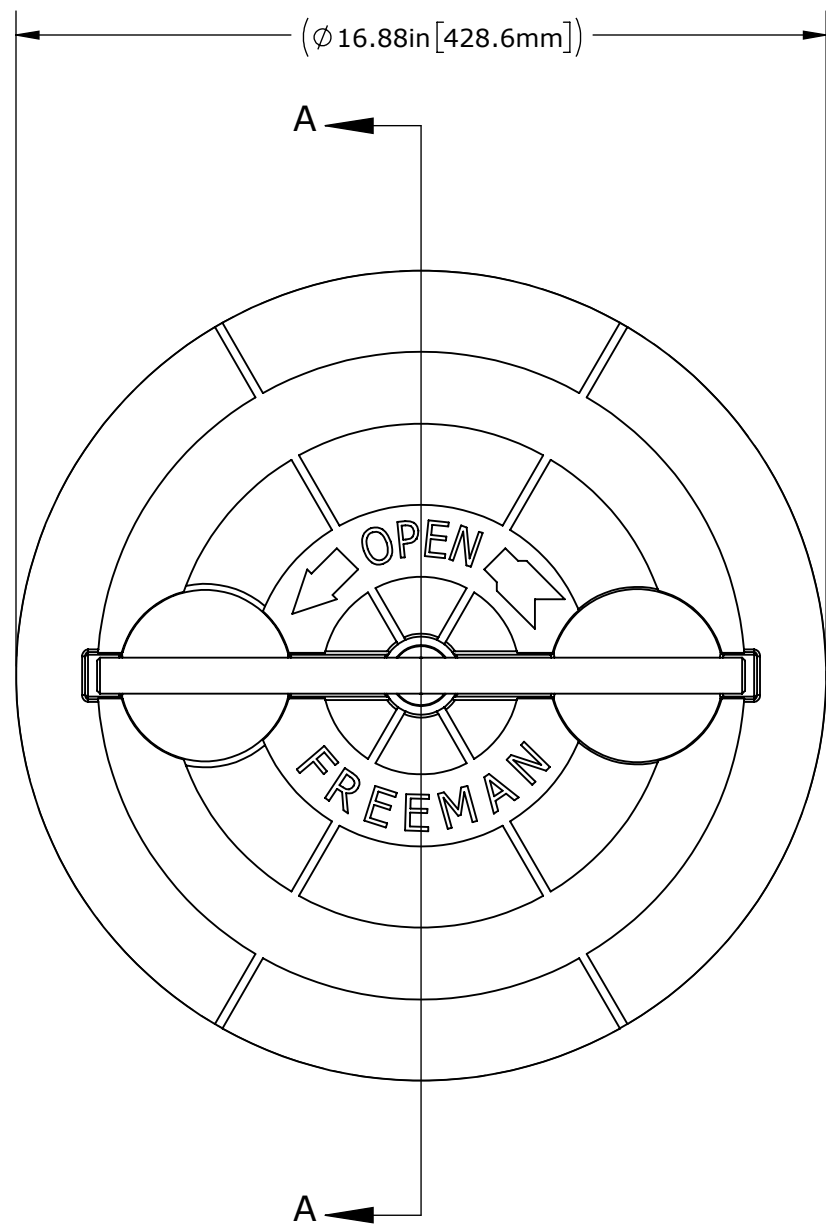
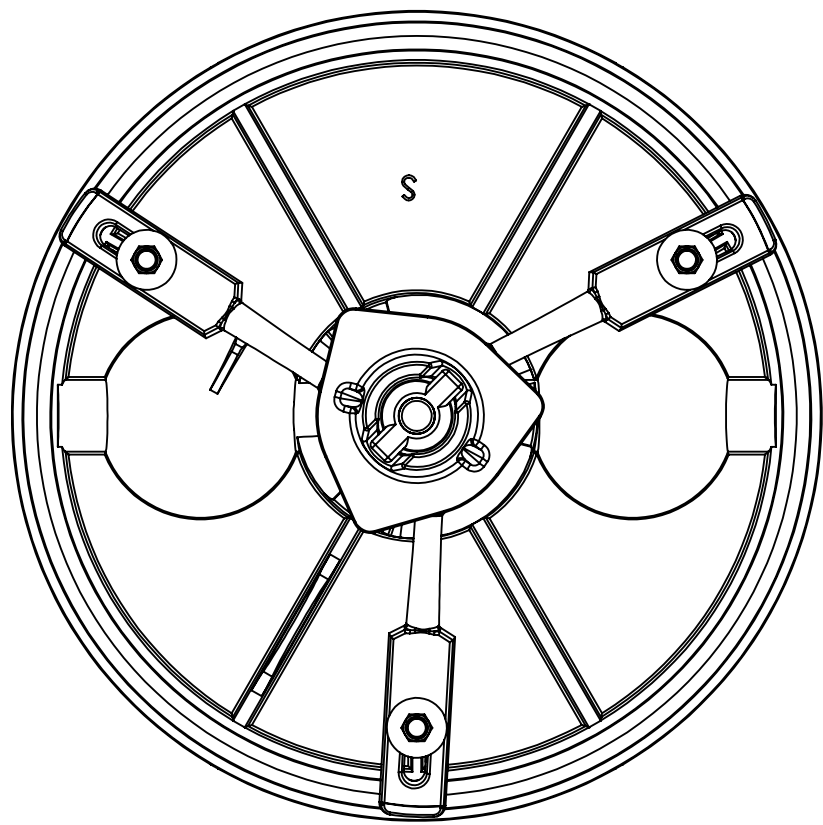

REVISIONS

REV.	DESCRIPTION	BY	DATE
00	PRODUCTION RELEASE	GB	5/18/2023

GENERAL NOTES

1. ALL DIMENSIONS SHOWN SUBJECT TO CASTING VARIATION AND ARE REFERENCE ONLY.
2. QUICK-ACTING, MECHANISM ENGAGES OR DISENGAGES IN QUARTER-TURN OF CENTER SPINDLE.
3. APPROX WEIGHT: 10.4 kg (22.9 lb).
4. FINISH: COVER-BARE, NO PAINT/PRIMER.

FOR ADDITIONAL INFORMATION CONTACT YOUR SALES REPRESENTATIVE OR PROJECT MANAGER.

CUSTOMER APPROVAL

IMPORTANT! THIS DRAWING SUPERSEDES ALL OTHER DOCUMENTS. BY SIGNING THIS APPROVAL YOU ACCEPT AND AGREE THAT THE DIMENSIONS AND DETAILS SHOWN ARE CORRECT AND PROPERLY FIT YOUR APPLICATION, REGARDLESS OF ANY DIFFERENCES BETWEEN THIS DRAWING AND ANY PRIOR CONTRACT SPECIFICATIONS. SHOULD YOU HAVE ANY QUESTIONS OR SEE ANY ERRORS, DO NOT SIGN THIS APPROVAL UNTIL THE DRAWING IS CORRECTED.

SIGN _____ DATE _____

UNLESS OTHERWISE SPECIFIED, DIMENSIONS ARE IN MILLIMETERS. TOLERANCES FOR ROUGH AND CLEAR OPENINGS ARE ±3mm (.125"). ALL OTHERS ARE:

METRIC	X	.X	.XX	ANGLES
	±2.5	±.8	±.25	±2°
IMPERIAL	.X	.XX	.XXX	ANGLES
	±.1	±.03	±.010	±2°

CAGE CODE
64747



COPYRIGHT 2016 ADVANTEC GLOBAL INNOVATIONS. ALL RIGHTS RESERVED. CONFIDENTIAL PROPERTY OF ADVANTEC GLOBAL INNOVATIONS. UNAUTHORIZED USE, REPRODUCTION OR DISTRIBUTION IS STRICTLY PROHIBITED. COPIES REMAIN THE PROPERTY OF ADVANTEC GLOBAL INNOVATIONS AND MUST BE RETURNED UPON REQUEST.

CLIENT
FREEMAN MARINE

PROJECT TITLE
STANDARD HATCH CPA

DWG TITLE
HATCH, 15 AL COVER

SCALE	DRAWN	DATE	CHECKED	DATE	SIZE
1:4	GB	5/18/2023	MS	5/18/2023	B

S.O. NO	DWG NO	SHEET	REV
	2403-1001	1 of 1	00