

MATERIAL

EPDM

REVISIONS

REV.	DESCRIPTION	BY	DATE
00	PRODUCTION RELEASE	ZC	2/17/22
1	PART DESCRIPTION UPDATE	GG	12/8/2022

GENERAL NOTES

1. GASKET D150 FRAME

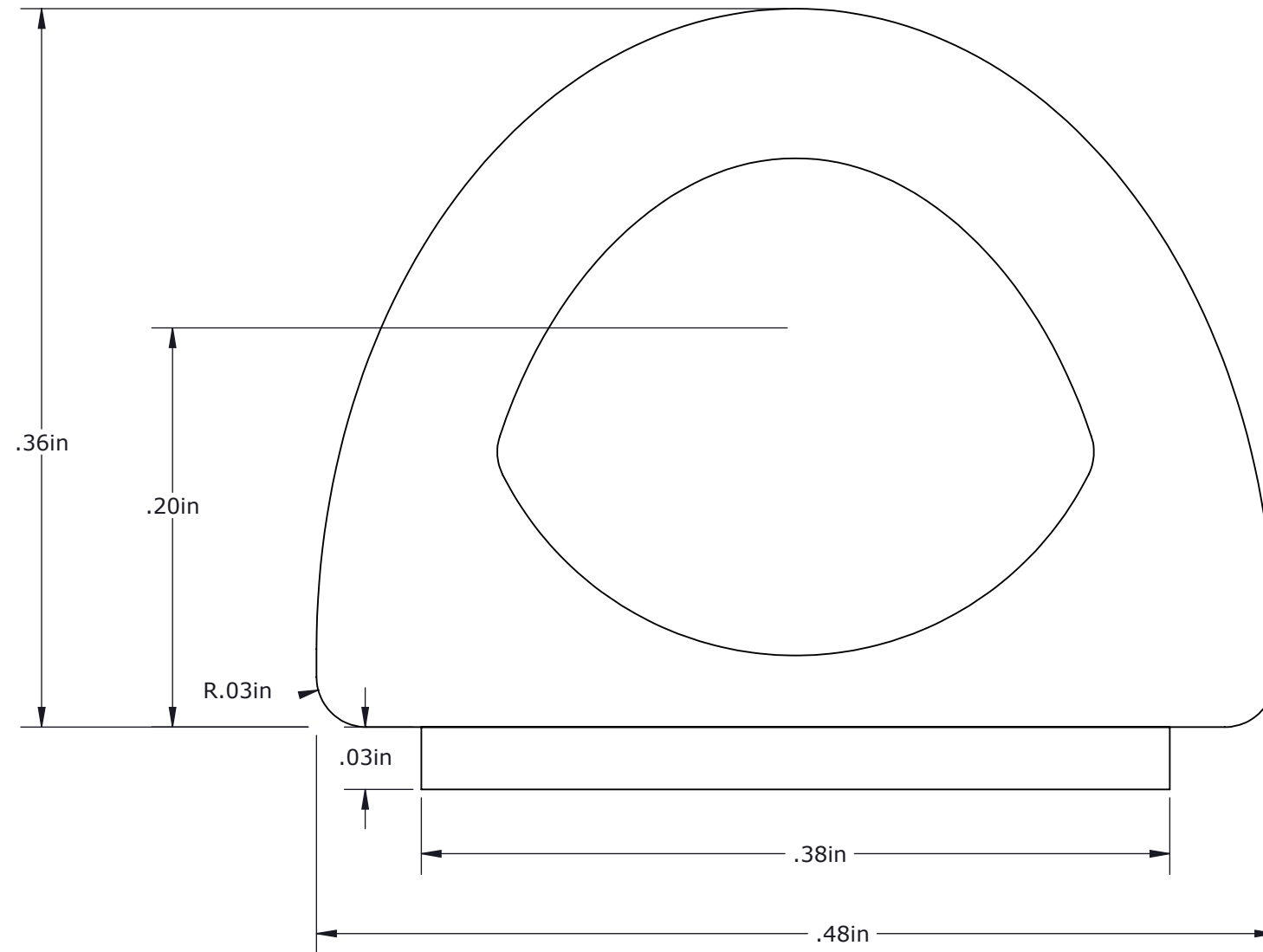

UNLESS OTHERWISE SPECIFIED, DIMENSIONS ARE IN MILLIMETERS. TOLERANCES FOR ROUGH AND CLEAR OPENINGS ARE ±3mm (.125"). ALL OTHERS ARE:

METRIC	X	.X	.XX	ANGLES
	±2.5	±.8	±.25	±2°
IMPERIAL	.X	.XX	.XXX	ANGLES
	±.1	±.03	±.010	±2°

BAR CODE CAGE CODE



COPYRIGHT 2016 ADVANTEC GLOBAL INNOVATIONS. ALL RIGHTS RESERVED. CONFIDENTIAL PROPERTY OF ADVANTEC GLOBAL INNOVATIONS. UNAUTHORIZED USE, REPRODUCTION OR DISTRIBUTION IS STRICTLY PROHIBITED. COPIES REMAIN THE PROPERTY OF ADVANTEC GLOBAL INNOVATIONS AND MUST BE RETURNED UPON REQUEST.

DWG TITLE
GASK EPDM BLK 0360IN X
0.50IN 1 SD HIT ADH

SCALE	DRAWN	DATE	CHECKED	DATE	SIZE
12:1	ZC	2/17/2022			B

S.O. NO	DWG NO	SHEET	REV
	103024	1 of 1	1