

Savia Dining Table

ASSEMBLY INSTRUCTIONS

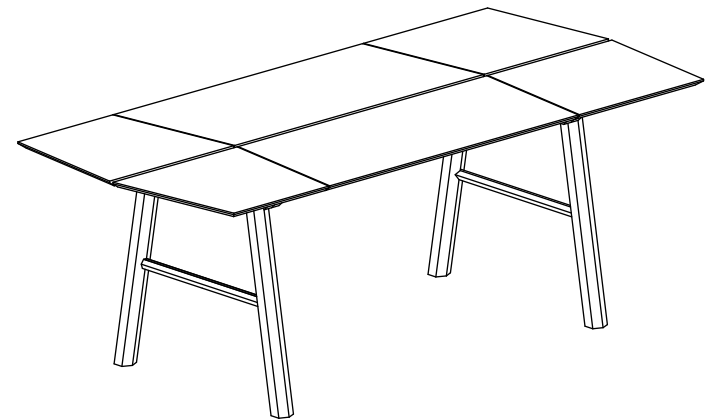

Woodendot

LIVE DESIGN



Approximate assembly time: 30 minutes



It is recommended to use an electric screwdriver, but be careful not to force it, it can damage the table



Assembly by 2 persons is recommended



A blanket or similar is recommended



It is recommended to use a hammer

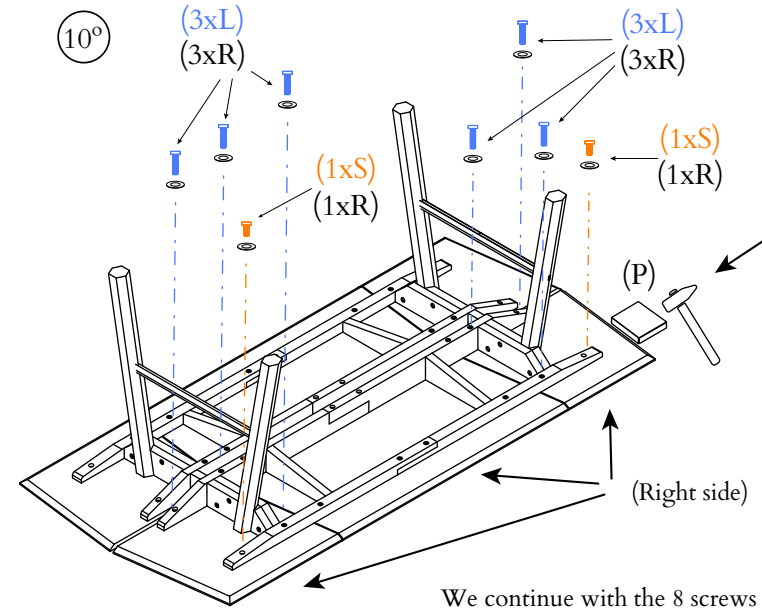
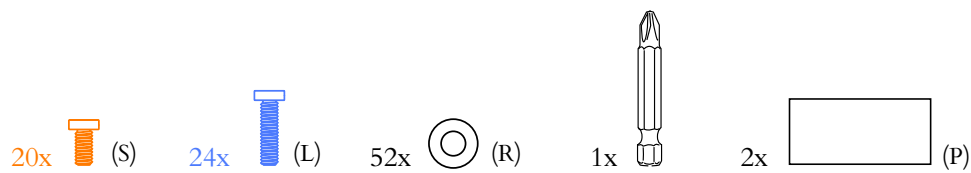
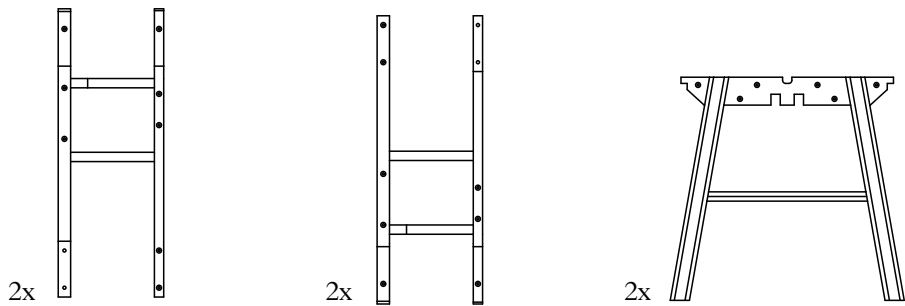
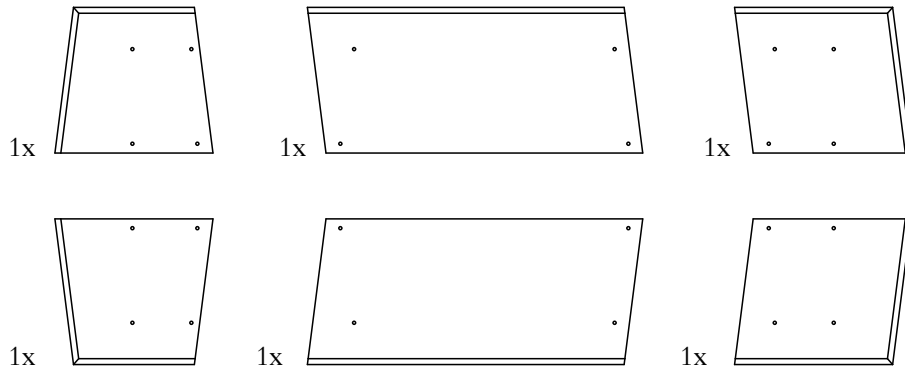

We continue with the 8 screws located at the ends. Please note that two of them are small screws (S). We can use the hammer and the piece (P) if any part of the table has been separated. It is important to align the holes correctly before screwing in.

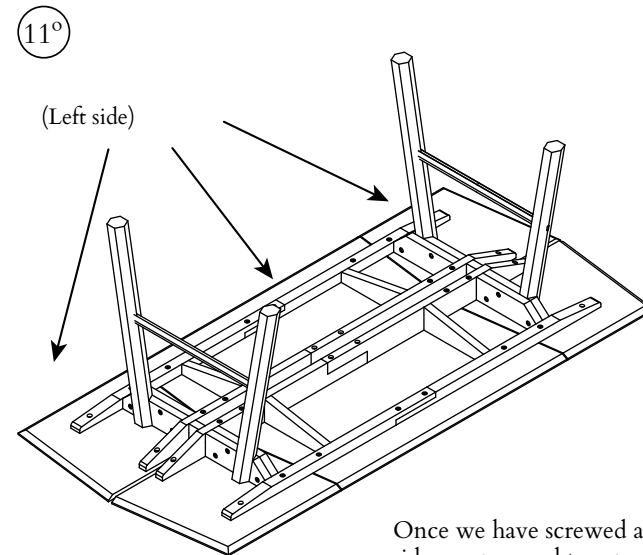

Once we have screwed all the screws on the right side, we proceed to repeat step 9 and 10 with the left side. Then, you can turn the table between two people by holding the ends.

4°

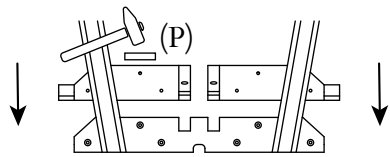
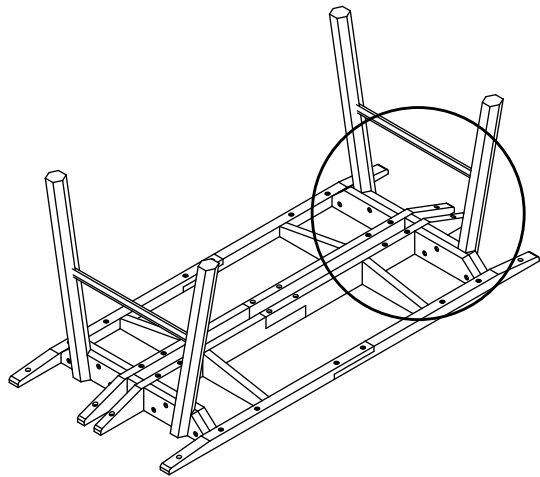

4-A

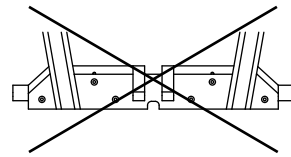

No

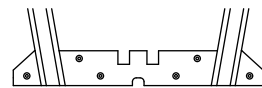

Yes

4-B

Put the legs at the ends. Follow these steps:

- 4.1 Place each leg at one end (see drawing 4-A)
- 4.2 Try to put both legs in at the same time.
- 4.3 The table is designed so that these legs fit very precisely ensuring the stability of the assembly, you can help yourself with a hammer and the piece of wood (P) that comes in the packaging to join the legs to the frame by hitting on the piece (P) without damaging the table.
- 4.4 Before screwing in, make sure that the frame and legs are flush with each other, as shown in drawing 4-B

5°

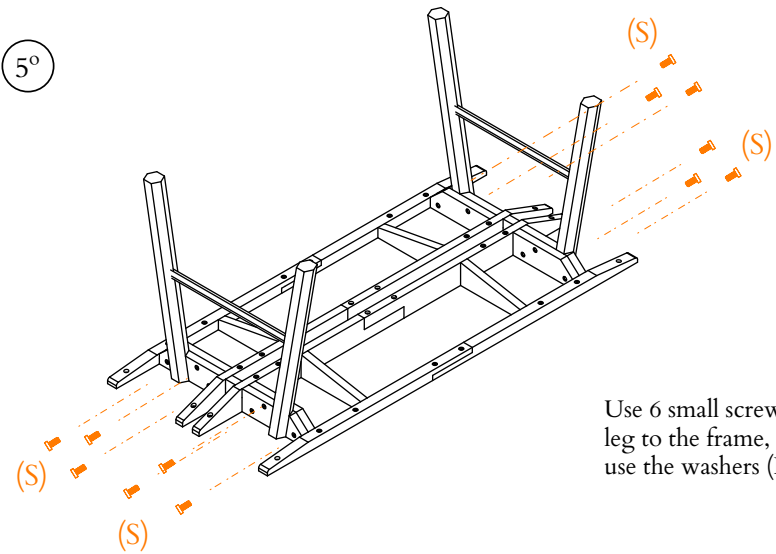

Use 6 small screws (S) to attach each leg to the frame, this time do NOT use the washers (R).

6°

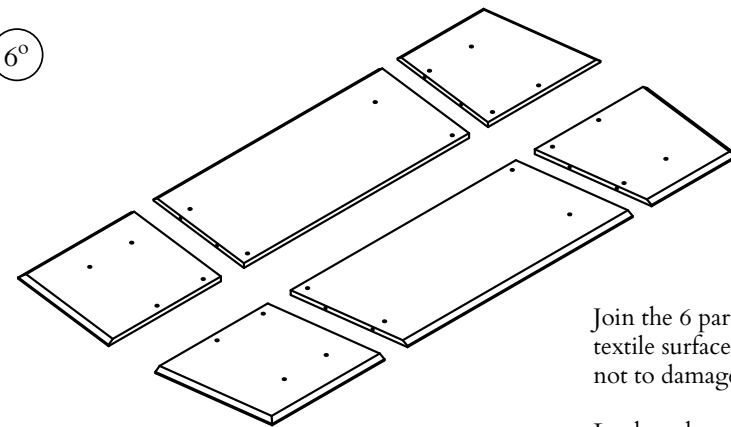

Join the 6 parts of the table on a textile surface such as a blanket, so as not to damage the table.

Look at the perimeter profile so you don't make a mistake.

7°

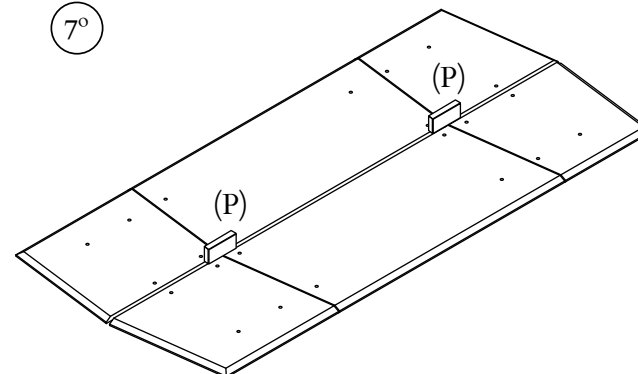

Use the wood pieces (P) to separate one part from another, as shown in the picture and once positioned remove.

8°

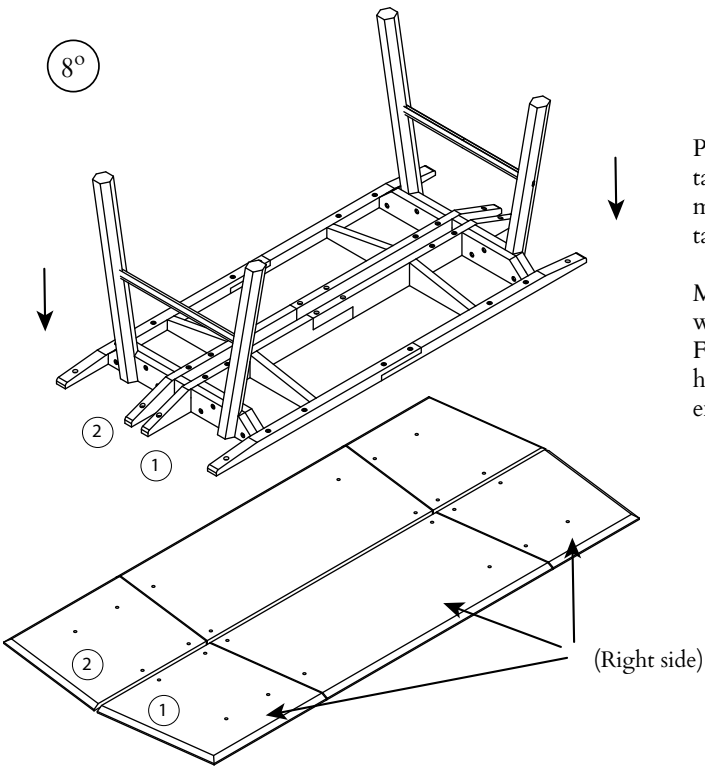

Place the entire structure on the tabletop. Frame number 1 must match the piece on the number 1 tabletop.

Match the holes in the frame with the holes in the tabletop. First we focus on matching the holes on one of the two sides, for example the Right side.

1°

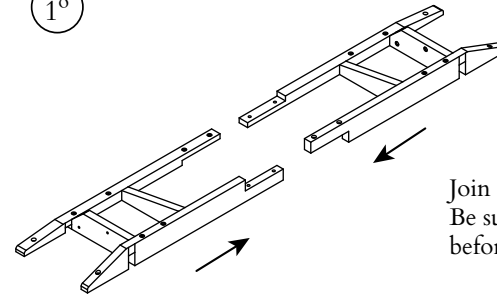

Join the two pieces of frame number 1. Be sure to put the two frame parts together before screwing in the 4 screws.

2°

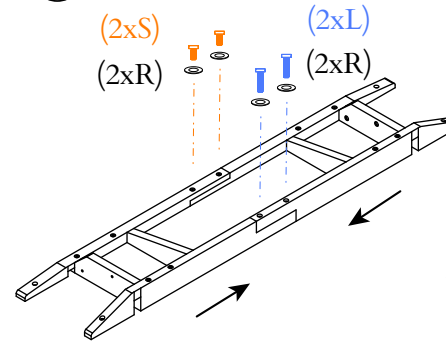

Join the two parts of frame number 1 using 2 large screws (L) and 2 small screws (S) together with the washers (R).

Repeat the operation with the number 2 frame.

9°

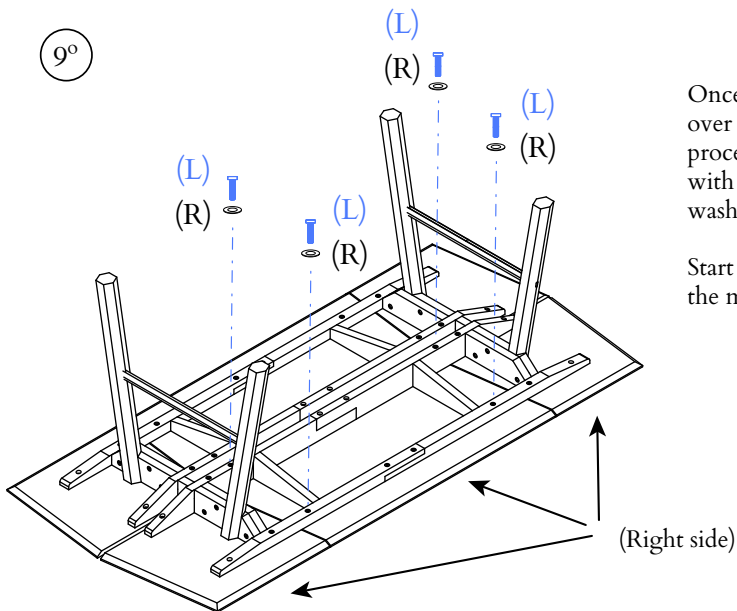

Once the leg frame is positioned over the holes in the tables, we proceed to join the two parts with the large screws (L) and washers (R).

Start by screwing the 4 screws in the middle.

3°

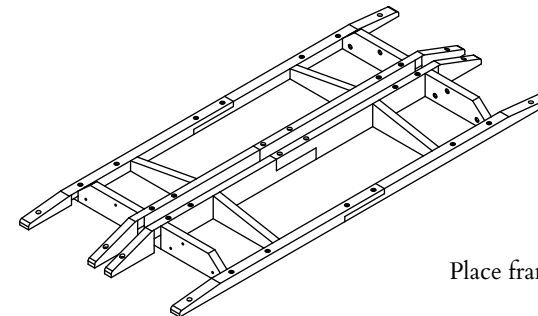

Place frames 1 and 2 in parallel.