

Sound insulating floor system

GypFloor SILENT is specified in residential conversion or improvement work to upgrade an existing timber joist floor. It is also used in new-build to meet the acoustic requirements of national Building Regulations to reduce sound transmission through upper floors. It should be used in conjunction with an appropriate ceiling lining.

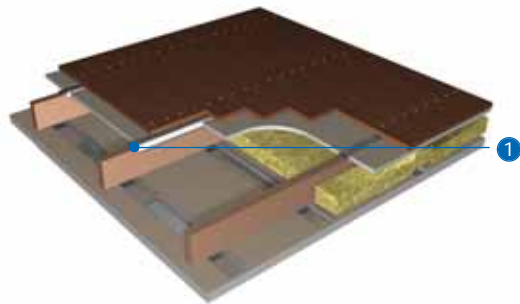



1 Gypframe SIF1 Floor Channel, Gypframe SIF2 Floor Channel or Gypframe SIF4 Floor Channel.

Key facts

- Dramatically improves airborne and impact sound insulation of existing timber joist floors
- Minimal increase in floor depth
- Used in conversion work and refurbishment to meet acoustic regulations
- Resilient interface between channel and floor joist

Components

Gyproc and Glasroc products

			Take-off quantities ¹
	Gyproc WallBoard^{2,3}		100m ² per layer
	Thickness	12.5mm	
	Width	1200mm	
	Gyproc SoundBloc²		100m ² per layer
	Thickness	12.5, 15mm	
	Width	1200mm	
	Gyproc FireLine²		100m ² per layer
	Thickness	15mm	
	Width	1200mm	
	Gyproc Plank		100m ² for floor 100m ² for ceiling if specified
	Thickness	19mm	
	Width	600mm	
	Glasroc MultiBoard		150m ² for Glasroc bridges if specified
	Thickness	12.5mm	
	Width	1200mm	

¹ Quantities are for 100m² of regular shaped rectangular floor, based on joists of 75mm or less at 400mm centres, with a chipboard walking surface and a double layer ceiling installation with Gypframe RB1 Resilient Bar component at 450mm centres. Quantities are approximate and for guidance only, no allowance has been made for waste. Can be used in conjunction with CasoLine MF ceiling or GypLyner UNIVERSAL ceiling sections.



Gypframe metal products

			Take-off quantities ¹
	Gypframe SIF1 Floor Channel		250m
	Length	2000mm	
	Width	127mm	
	Gypframe SIF2 Floor Channel		as required
	Length	2000mm	
	Width	85mm	
	Gypframe SIF4 Floor Channel		250m
	Length	2000mm	
	Width	140mm	
	Gypframe RB1 Resilient Bar		250m
	Length	3000mm	

² Moisture resistant boards are specified in intermittent wet use areas e.g. shower cubicles.

³ Also available in DUPLEX grades where vapour control is required.

Fixing and finishing products	Take-off quantities ¹
 <p>Gypframe SIF5 Floor Screws For fixing floorboards through Gyproc Plank into the Gypframe floor channel flange.</p>	1250
 <p>Gyproc Drywall Screws For fixing boards to Gypframe RB1 Resilient Bars, and Gypframe RB1 Resilient Bars to timber joists.</p>	1800 per layer
 <p>Gyproc Sealant For sealing air paths to achieve optimum sound insulation.</p>	1 cartridge per 35m based on a 6 - 10m bead
 <p>Gyproc jointing materials For seamless jointing.</p>	as required

Fixing and finishing products	Take-off quantities ¹
 <p>Thistle Multi-Finish or Thistle Board Finish To provide a plaster skim finish.</p>	10m ² per 25kg bag
 <p>Thistle Spray Finish Gypsum finish plaster for spray or hand application.</p>	11m ² per 25kg bag
 <p>Isover General Purpose Roll For providing acoustic / thermal insulation.</p>	100m ²

Construction tips

- Estimated construction time 0.5m²/ man hour - ready for finishing
- The system will add approx. 7mm height to the finish floor level
- The finished surface of the applied ceiling will be 48mm from the underside of the joists (when Gypframe RB1 Resilient Bar, a layer of Gyproc Plank and 12.5mm Gyproc SoundBloc are applied)
- The system is primarily intended for traditional solid timber joist floors – intensity of distributed load of up to 5.0kN/m² and a concentrated load of 4.5kN/m²
- In refurbishment work check the level of existing joists is not misaligned – if so consider **GypLyner** systems or **CasoLine MF** suspended ceiling to the underside of the joists
- Ensure tops of joists are level to accommodate SIF floor channels
- Ascertain the correct Gypframe SIF Floor Channel to use - Joist width up to 63mm use Gypframe SIF1 Floor Channel, joist widths between 64 -75mm use Gypframe SIF4 Floor Channel and joists over 75mm use Gypframe SIF2 Floor Channel (2 per joist position unless adjacent to the wall)

Construction tips (cont'd)

- To maintain optimum sound insulation consider the following:
 - Ceilings should be fixed prior to drylining / plastering on walls. If this is not possible abut the ceiling against the wall surface
 - If an existing ceiling is being retained additional sound insulation will be required – contact British Gypsum for further guidance
 - Make suitable provision to minimise flanking sound in the surrounding structure
 - Seal the perimeter, including gaps between wall and floor linings with Gyproc Sealant
 - Glue joints of chipboard flooring
 - Gypframe SIF Floor Channel must not be mechanically fixed to the joists

Installation - Floor



Installation (standard) for joists 63mm or less

- Locate Gypframe SIF1 Floor Channel sections centrally over the joists, leaving a 6mm clearance gap at walls.
- Where joints in channel occur, butt the sections together.



2

- Where joists run close to the wall (30mm gap or less), locate Gypframe SIF2 Floor Channel in place of Gypframe SIF1 Floor Channel.



3

- Stop SIF channels either side of strutting or services which interrupt channel location.



4

- Where joists overlap, cut away the channel legs to allow channels to run through.



• Cut Gyproc Plank to a neat (not tight) fit between channels. Allow a 3mm gap between Gyproc Plank and channel sides.

NB Ensure that the vertical flanges of the channels do not impinge on the sides of the joists when the Gyproc Plank infills are installed.

NB To minimise waste cut Gyproc Plank across its length to create tiles which lie bound edge to bound edge.



• Lay flooring across the channels and screw-fix through the Gyproc Plank to the channel flange on one side only using a Gyppframe SIF5 Floor Screw (see Figure 12).



Services

• Where water pipes or other services penetrate the floor, cut Gyproc Plank and flooring to allow a small clearance. Seal any gaps in order to minimise loss of acoustic performance, and suitably fire-stop (if required).

Installation - RB1 Ceiling



- Mark the underside of joists at 450mm centres to indicate the positioning of Gyproframe RB1 Resilient Bars (centres will be 400mm for 2400mm long board).
- Fix Gyproframe RB1 Resilient Bars through their flange to each joist using 36mm Gyproc Drywall Screws.
- If the resilient bars are not long enough to span the ceiling, join by nesting together under a joist and a screw through both flanges.

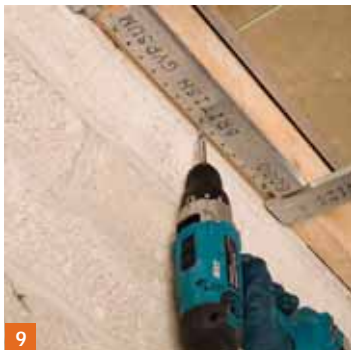

- Cut Gyproframe RB1 Resilient Bar noggings to fit between the rows of bar at the ceiling perimeter and screw-fix to the joist.



- Lay Isover General Purpose Roll (100mm) between joists to rest on the resilient bars.
- Fix base layer board to the resilient bars using appropriate length Gyproc Drywall Screws with the long edge of boards at right angles to the resilient bars.
- Insert screws at 230mm maximum centres in the field of boards, and 150mm maximum centres at board ends.



- Fix face layer board through to all resilient bar supports using appropriate length Gyproc Drywall Screws. Insert screws no closer than 10mm from bound board edges and 13mm from cut edges. Stagger board joints in the second layer relative to the first (see **Junction details**).

NB Select length of fixing to provide a nominal 10mm penetration into the Gypframe RB1 Resilient Bar supports. Ensure no contact of screw with timber joists.

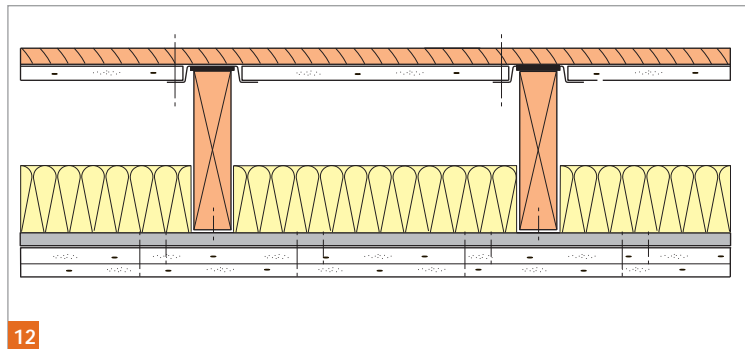

12

Typical section through floor

- Gypframe SIF1 Floor Channel - for joists up to 63mm wide
- Gypframe SIF4 Floor Channel - for joists 64 - 75mm wide

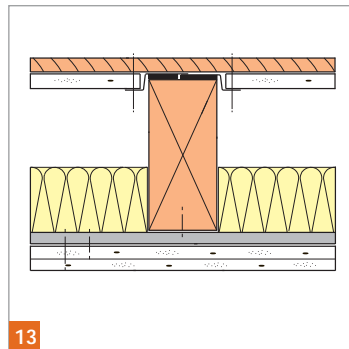

13

Installation for joists over 75mm

- As standard but use two Gypframe SIF2 Floor Channels per joist.
- Cut away the foam inlay on one channel to facilitate overlap, and leave a 2 - 3mm clearance gap between each channel and the side of the joist.

Junction details

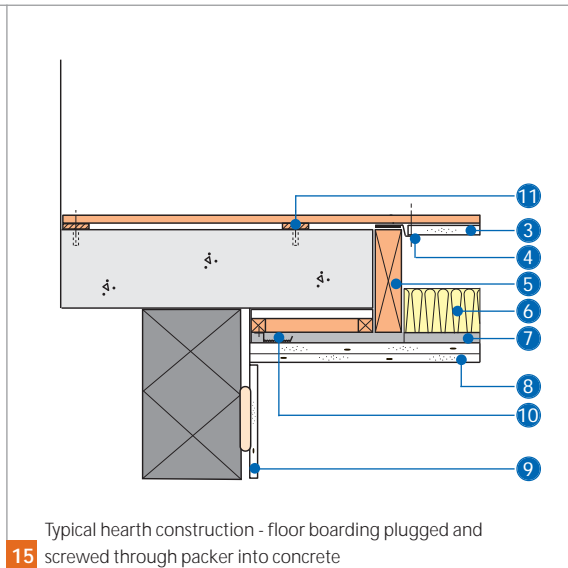
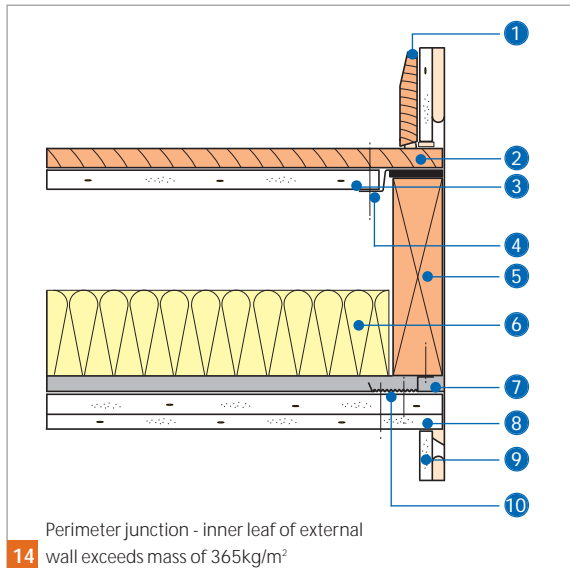

- ① Skirting
- ② Chipboard / softwood flooring
- ③ Gyproc Plank
- ④ Gypframe SIF2 Floor Channel

- ⑤ Solid timber joist.
- ⑥ 100mm Iover General Purpose Roll
- ⑦ Gypframe RB1 Resilient Bars
- ⑧ Ceiling lining boards

- ⑨ Wall lining
- ⑩ Gypframe RB1 Resilient Bar noggings
- ⑪ Packer

Junction details

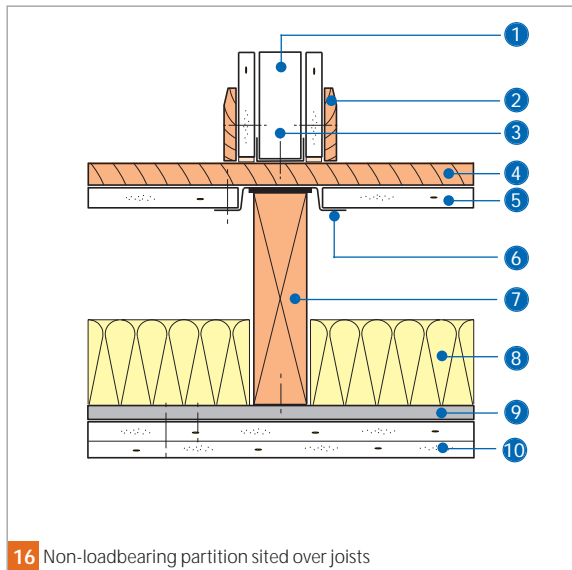

Siting of non-loadbearing partitions

- Where the partition is required to run parallel to the joists, but not directly over them, provide joist noggings at 600mm intervals.
- Cap the noggings with short lengths of Gypframe SIF1 Floor Channel under the line of the partition.

1 **GypWall** partition

2 Skirting

3 Fixing length selected to avoid reaching the Gypframe SIF1 Floor Channel

4 Chipboard / softwood flooring

5 Gyproc Plank

6 Gypframe SIF1 / SIF4 Floor Channel

7 Solid timber joist

8 100mm Isover General Purpose Roll

9 Gypframe RB1 Resilient Bars

10 Ceiling lining boards

Junction details - plan drawings

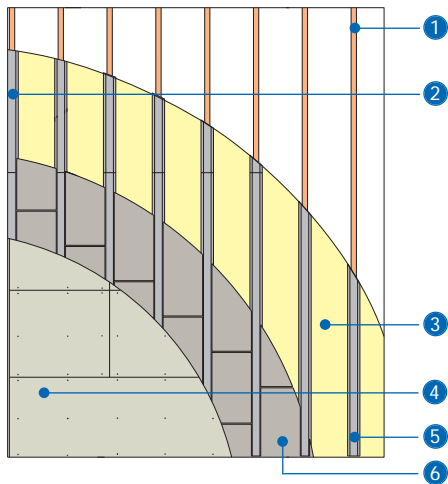

17 Cut-away floor plan (chipboard flooring)

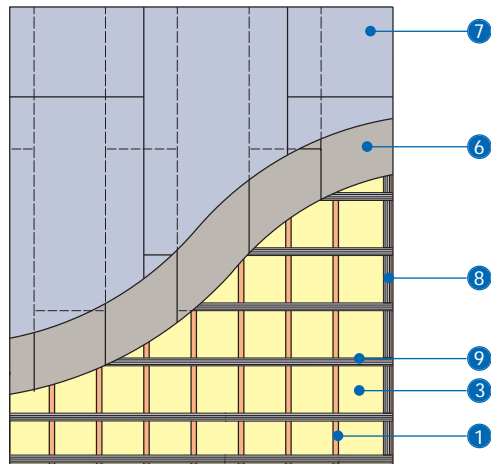

18 Reflected ceiling plan (12.5mm x 1200mm x 2700mm Gyproc SoundBloc over Gyproc Plank fixed to Gyproframe RB1 Resilient Bars)

- | | | |
|--|---|--|
| 1 Solid timber joists | 5 Gypframe SIF1 / SIF4 Floor Channel | 8 Gypframe RB1 Resilient Bar noggings at room perimeter |
| 2 Gypframe SIF2 Floor Channel | 6 Gyproc Plank | 9 Gypframe RB1 Resilient Bar |
| 3 Isover General Purpose Roll (100mm) | 7 Gyproc SoundBloc | |
| 4 Chipboard flooring | | |