

FUNKY Monkey bars[®]

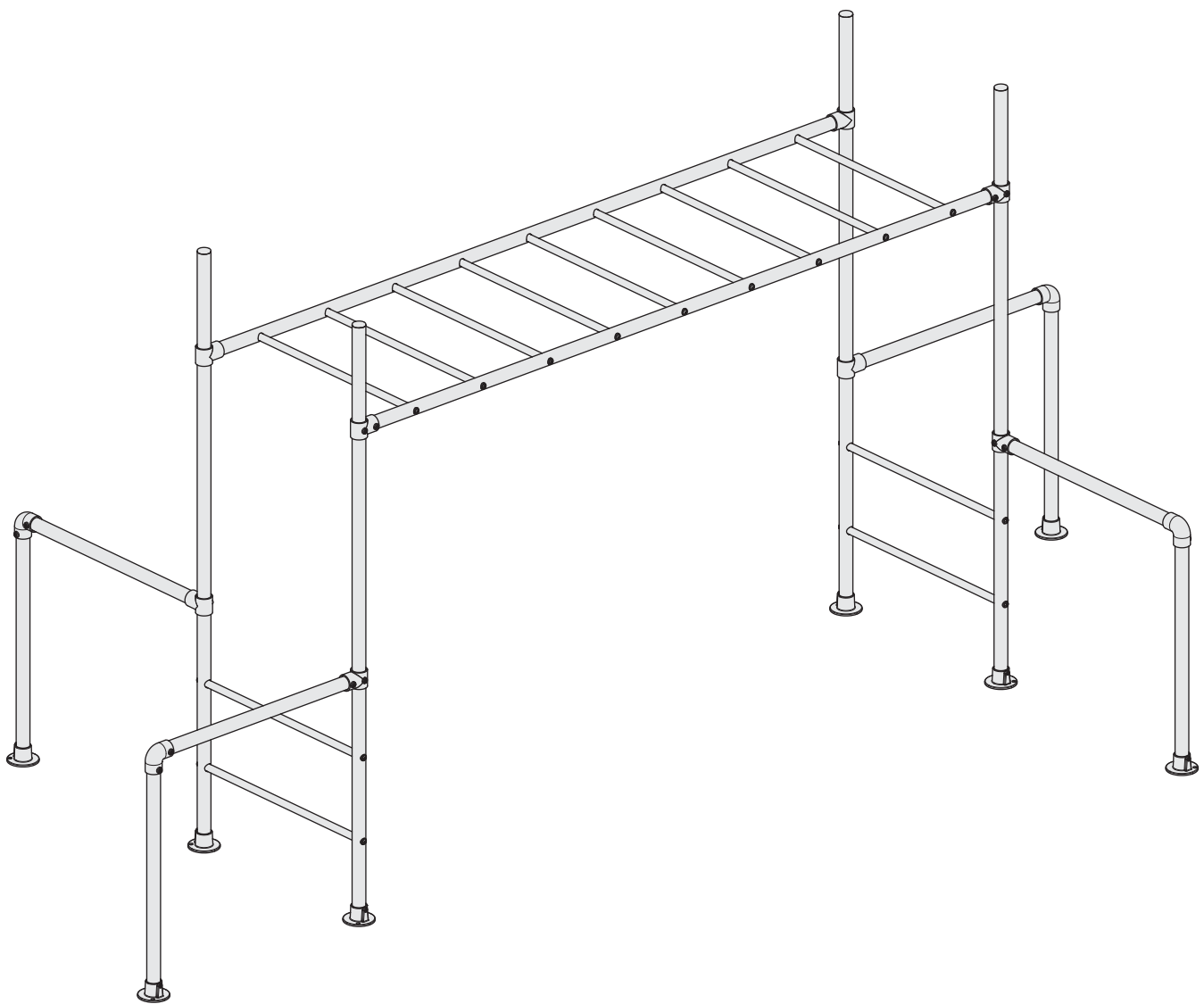

**THE ORIGINAL
ASSEMBLY INSTRUCTIONS**

CONTENTS

Warnings	Page 1
Load Rating	Page 3
Dimensions	Page 4
Assembly Tips	Page 5
Inventory	Page 7
Assembly Instructions	Page 9
Ladder Bar Assembly	Page 9
Leg Assembly	Page 11
Twirly Whirly Bar Assembly	Page 15
Main Monkey Bar Assembly	Page 16
Load Twirly Whirly Bars	Page 19
Sticker Placement Guide	Page 20
Maintenance	Page 22

WARNING

PLEASE CAREFULLY READ ALL INFORMATION CONTAINED IN THIS ASSEMBLY MANUAL BEFORE YOU INSTALL AND USE YOUR FUNKY MONKEY BARS®.

SAFETY NOTICE

1. Any person handling or using the Funky Monkey Bars® products must follow the instructions as described in this document. The person in charge of assembling and using the equipment must ensure that the recommendations for use given in this document are seen by all users.
2. Only use the Funky Monkey Bars® after they have been fully assembled and after checking that the fittings are tightened properly (*refer to page 5 - Correct Tightening Method*).
3. DO NOT install your Funky Monkey Bars® over concrete, asphalt, packed earth, wood decking or any other hard surface. A fall onto a hard surface can result in serious injury or death.
4. Inspect all grub screws, bolts and nuts at the beginning of each play session to ensure your Funky Monkey Bars® are tight and secure.
5. Ensure all tubes are fully inserted into fittings until you hear the magic "CLUNK" sound.
6. Ensure your Funky Monkey Bars® are properly secure at ALL times. Pegs are in place and inserted fully into the ground.
7. DO NOT exceed the maximum load/weight limit as recommended by Funky Monkey Bars®.
8. Children should be supervised by an adult at all times.
9. Installing a gym/crash mat under the fall zone area of your Funky Monkey Bars® would be recommended for children learning this new skill. This will reduce the chance of injury and build the child's confidence while they build strength and master the skill.
10. Ensure you have thoroughly read your assembly and installation instructions and viewed our on-line installation videos at <https://www.funkymonkeybars.com/blogs/installation-maintenance-videos>
11. DO NOT climb, sit or stand on top of the monkey bar (horizontal ladder) section.
12. DO NOT jump from the top of any section of the monkey bar.
13. DO NOT use your Funky Monkey Bars® when wet as the steel will be slippery.
14. DO NOT attach items to your frame that are not designed specifically to be used with Funky Monkey Bars®, especially lower quality products that have not been approved by Funky Monkey Bars®.
15. Ensure the height of your Funky Monkey Bars® (horizontal ladder) are set at a level that is age appropriate.
16. DO NOT install your Funky Monkey Bars® over or near objects that could interfere with users in an unsafe way. Maintain a clear area around your Funky Monkey Bars®.
17. DO NOT use your Funky Monkey Bars® while under the influence of drugs and alcohol.
18. Wear clothing free of drawstrings, hooks, loops or anything that could get caught while using your Funky Monkey Bars® and result in entanglement and/or strangulation.

ASSEMBLY

1. Keep small children away from the Funky Monkey Bars® during assembly.
2. Do not attempt to use the Funky Monkey Bars® until it is completely assembled and every fitting is tight and secured.
3. Installation typically takes 2-3 hours to complete. Two people are recommended for assembly.
4. Ensure all fittings are tightened to the correct tightening method as described on page 4.
5. Assembly should be carried out on clean, dry, level surface

Please refer to the video section on the Funky Monkey Bars® website for more handy tips and assembly instructions at <http://www.funkymonkeybars.com/pages/videos>

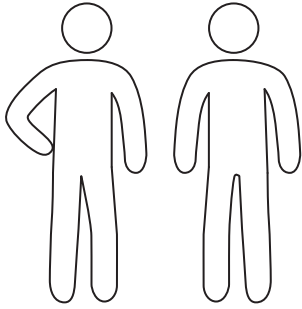

Assembly requires 2 adults.

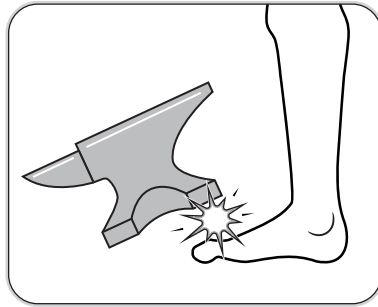

Heavy items !

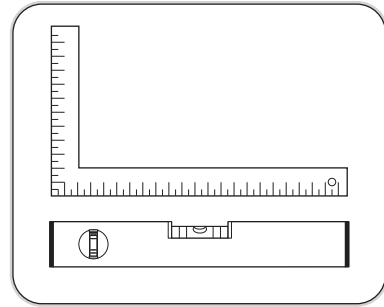

Work on flat level surface.

LOCATION

1. A safe fall zone around your Funky Monkey Bars® is essential. A minimum distance of 1.5m to 2m (5 ft to 6.5ft) is recommended around the elevated hanging points of your Funky Monkey Bars®.
2. Place your Funky Monkey Bars® on level ground, away from any structure or obstruction such as a fence, garage, house, overhanging branches, laundry lines or electrical wires and remove any obstructions beneath your Funky Monkey Bars®.
3. Ensure your Funky Monkey Bars® are positioned away from retaining walls, pool fences, structures and other play equipment. Maintain a clear space around the whole perimeter of your Funky Monkey Bars®.
4. Place your Funky Monkey Bars® on the most level surface available.

MAINTENANCE

1. At the beginning of each heavy play session we recommend the following maintenance processes be performed on your Funky Monkey Bars®:
 - Tighten all bolts, grub screws and applicable hardware (as per page 3)
 - Lubricate all metallic moving parts as per instructions (flying fox, swing hooks etc)
 - Check all protective coverings on bolts, pipes, edges and corners. Replace if they are loose, cracked or missing.
 - Check all moving parts including swing seats, shackles, snap hooks, chains and trolleys for wear, rust, or other deterioration. Replace as needed.
2. Twice a month during play season we would recommend the following maintenance processes be performed on your Funky Monkey Bars®:
 - Tighten all connections and hardware
 - Check all protective coverings on bolts, pipes, edges and corners. Replace if they are loose, cracked or missing.
3. Once a month during play season we would recommend the following maintenance processes be performed on your Funky Monkey Bars®:
 - Lubricate all metallic moving parts as per instructions (flying fox, swing hooks etc). If swings start to squeak then lubricate swing hooks.
 - Check all moving parts including swing seats, ropes, chains and trolleys for wear, rust, or other deterioration. Replace as needed.
 - Owners shall be responsible for maintaining the legibility of any warning labels.

For additional information concerning your Funky Monkey Bars®, please contact our customer service team or check our website for any important updates. Phone: 1300 912 198 or www.funkymonkeybars.com



QUALITY & INDEPENDENT TESTING

At Funky Monkey Bars® we take the quality of our designs and safety very seriously. All Funky Monkey Bars® frames go through a stringent, independent structural testing process prior to being made available for release to our customers.

Our frames are designed within the parameters of the Australian Standard for Playground Equipment AS4685.1:2014.

The structural integrity of our frames has been tested for performance through a combination of engineering calculations and physical testing. The tests have been performed by independent, certified structural engineers in accordance with Australian Standard for Playground Equipment AS4685.1:2014 and European Standards EN1176-1:2008.

The independent testing conducted on The Original certified the frame to a load rating of 486kgs or 7 users.

LOAD TESTING CERTIFICATION				
DATE OF TEST	MODEL	NUMBER OF USERS	USER LOAD (KG)	LOAD RATING (KG)
October 2015	The Original	7	69.5	486
I hereby confirm all testing was undertaken in accordance with Physical Testing of Structural Integrity requirements of AS 4685.1: 2014 App C / EN 1176-1:2008 ^o except where noted below;				
COMMENTS: N/A				
APPROVED BY: Funky Monkey Bars® 			WITNESSED BY: Independent Engineer 	
DATE : October 2015			DATE : October 2015	

DIMENSIONS

FUNKY MONKEY BARS® THE ORIGINAL OVERALL DIMENSIONS

A minimum of 2.0 Metres clear fall zone is recommended around the elevated hanging points of your Funky Monkey Bars®.

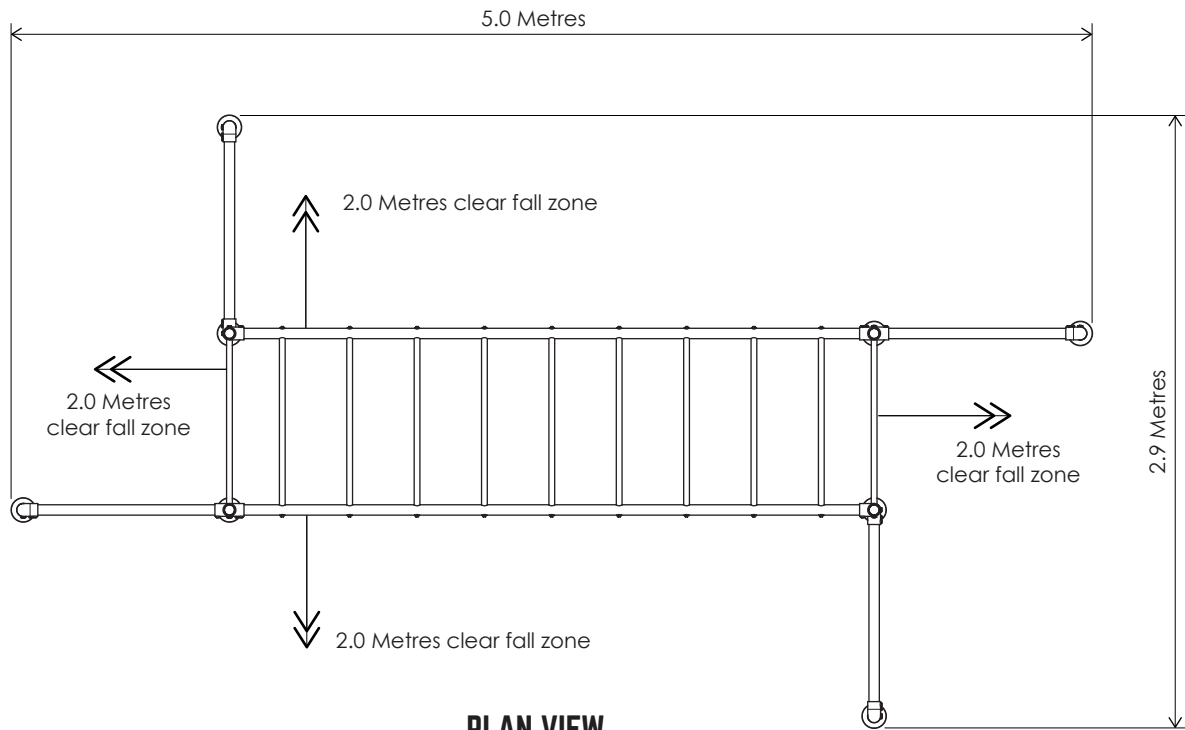

PLAN VIEW
(not to scale)

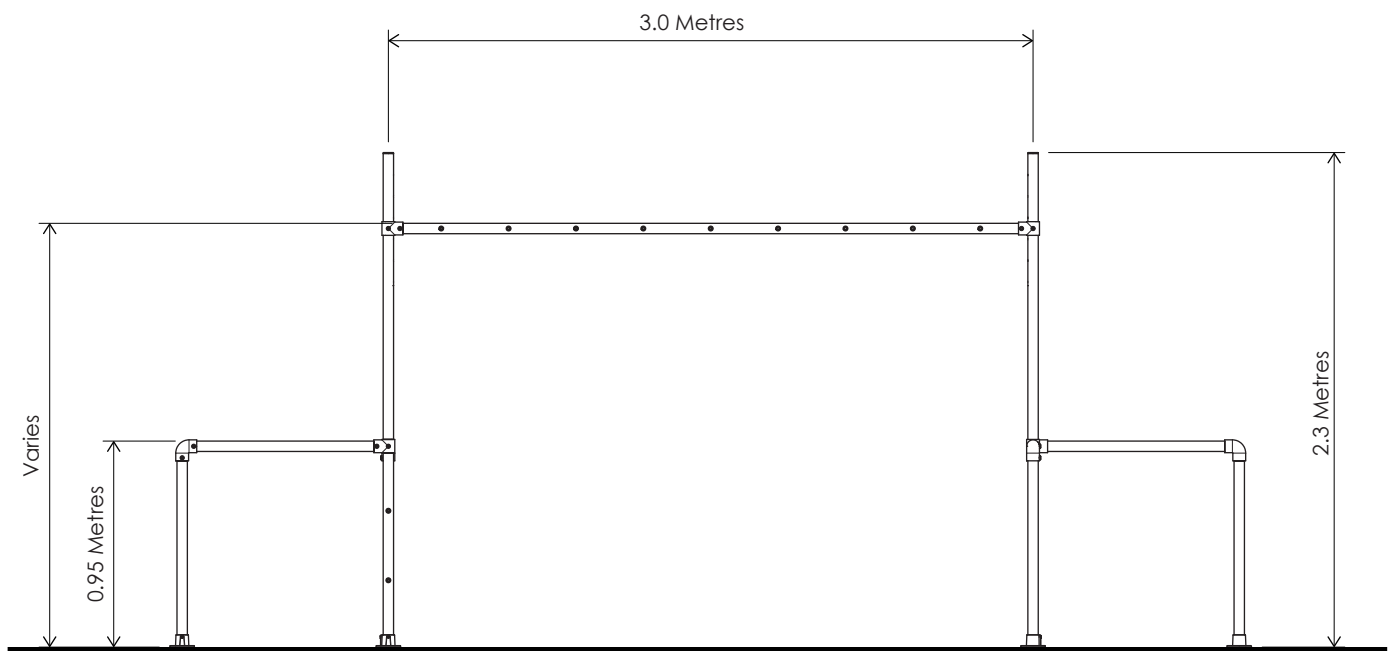

SIDE VIEW
(not to scale)

ASSEMBLY TIPS

CORRECT INSERTION INTO FITTINGS - (INDICATIVE DIAGRAM SHOWN)

All tubes must be fully inserted until contact is made with adjoining tube.

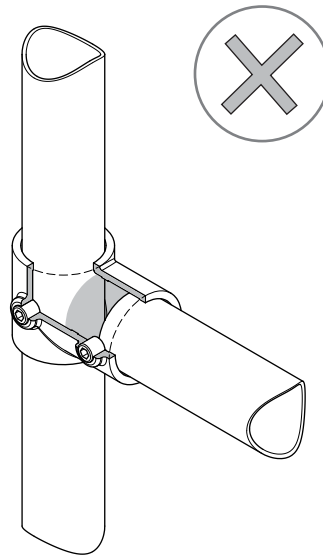

Gap.

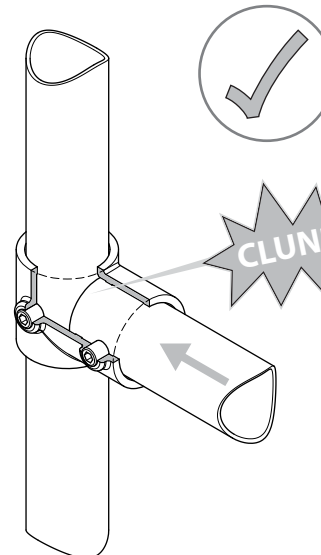

No gap.

CORRECT TIGHTENING METHOD OF GRUB SCREWS - (INDICATIVE DIAGRAM SHOWN)

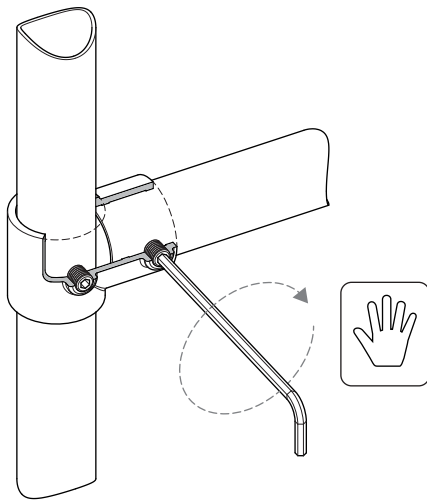

1. With long end of allen key, hand tighten grub screw as much as possible.

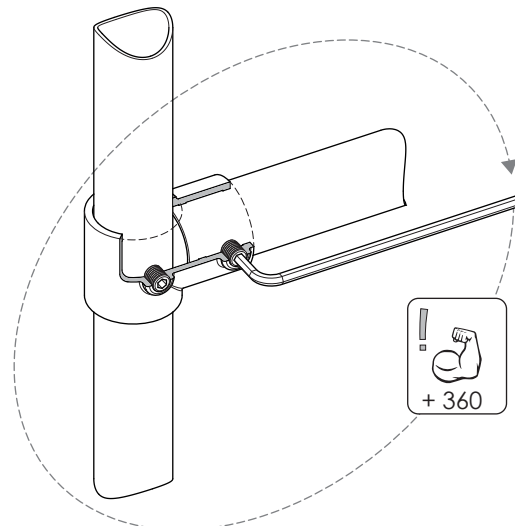

2. Using other end of the allen key do one full 360 degree turn as a minimum, use muscles!



CORRECT TIGHTENING METHOD OF RUNG BOLTS - (INDICATIVE DIAGRAM SHOWN)

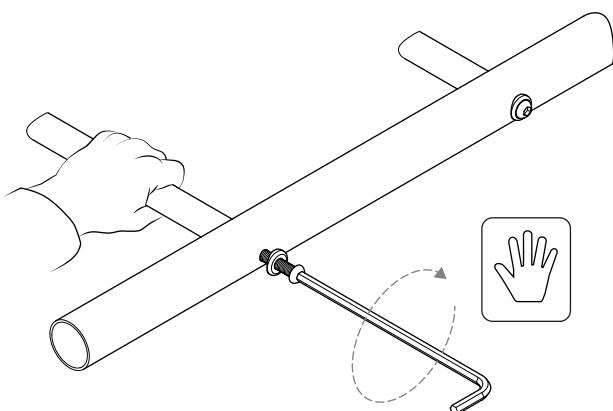

1. With long end of allen key, hand tighten bolt hard up against washer and outside of tube. Hold rung to avoid rotation.

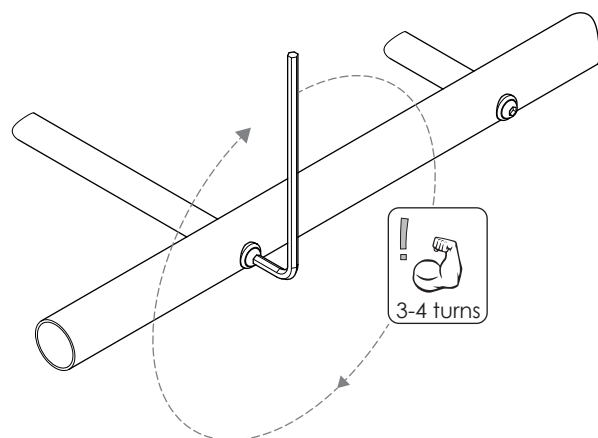

2. Using short end of the allen key fully tighten, approximately 3-4 full turns .



ASSEMBLY TIPS (CONTINUED)

IT IS CRITICAL YOUR MAIN FRAME IS 100% SQUARE AND LEVEL (INDICATIVE DIAGRAM SHOWN)

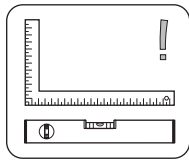

Check assembly is 100% level, square & straight.

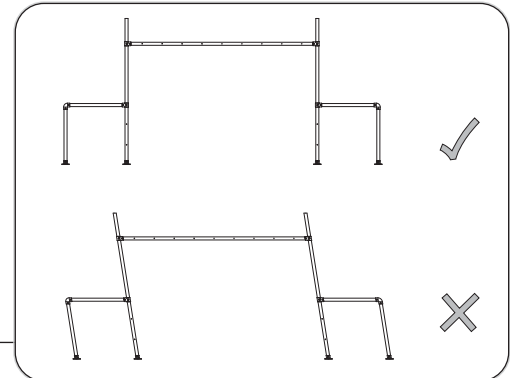
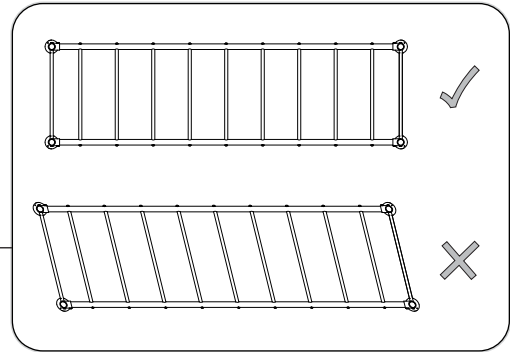
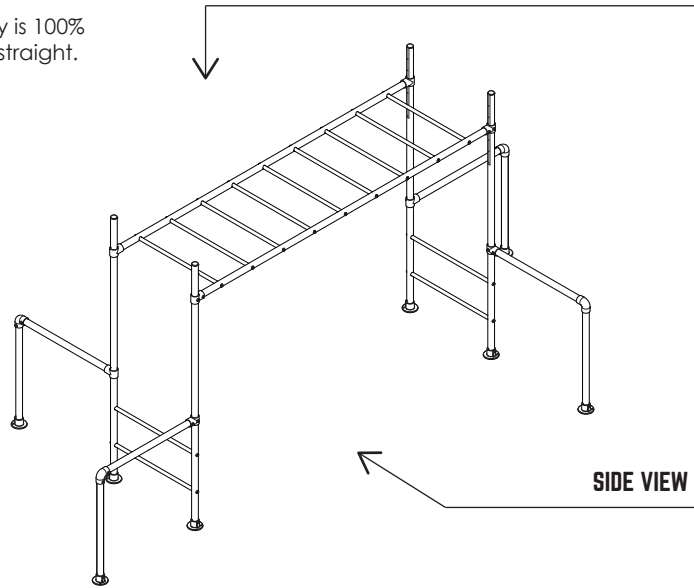

If your frame is not straight or level remove pegs, loosen grub screws, re-adjust re-tighten and re-peg the frame.

INSTALLATION ON A SLOPE

If your frame is being installed on a slope ensure the monkey ladder bar is level. Either install at different heights on the legs or dig down at one end until level.

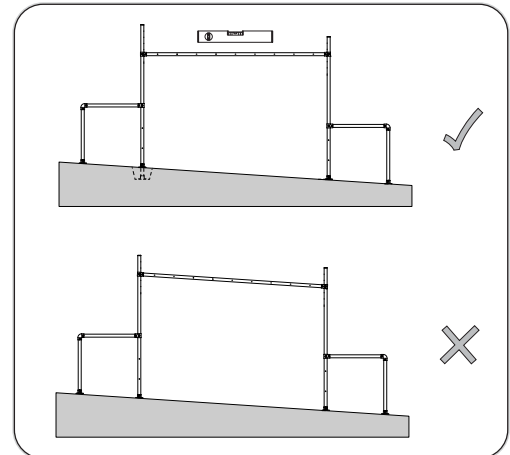

FIXING TYPICAL ORIENTATION - (INDICATIVE DRAWING SHOWN)

Unless otherwise stated all grub screws and fittings should face downwards and outwards. This will reduce weathering damage, help with assembly and ease of maintenance.

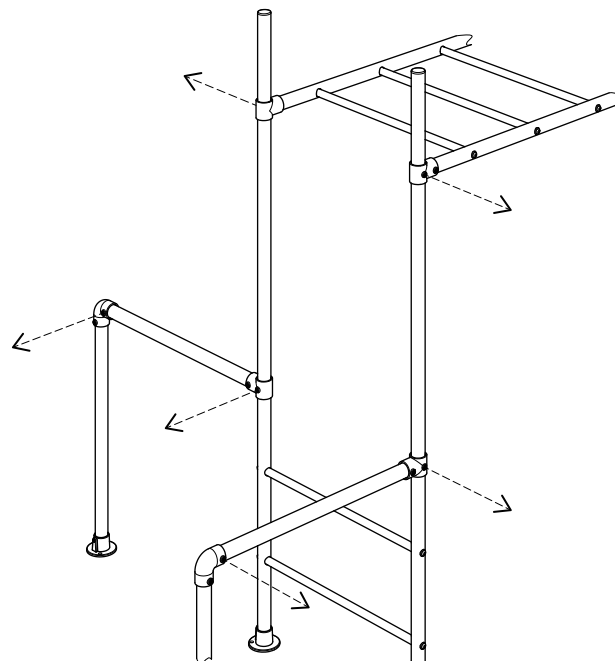

INVENTORY

TOOLS REQUIRED FOR INSTALLATION

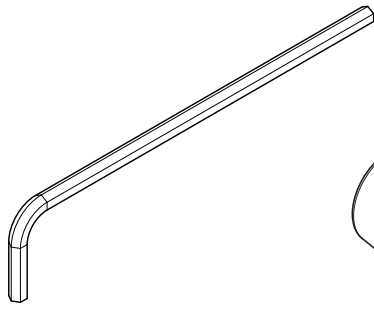

1x
8mm Allen key
(Included)

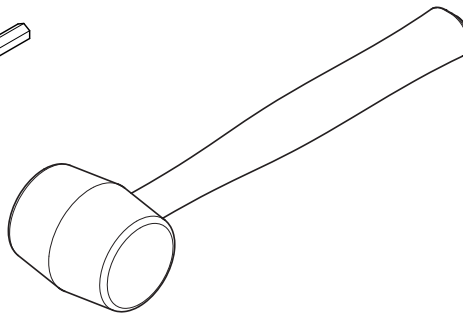

1x
Soft Hammer
(Not included)

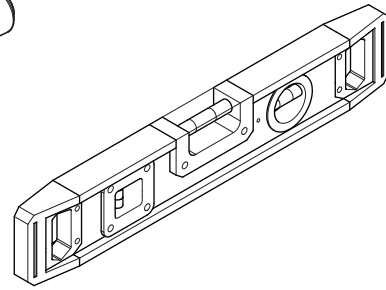

1x
Spirit Level
(Not included)

TUBES

13x
Rung Tube 25Dia. x 850mm

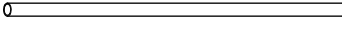

8x
Twirly Tube 50Dia. x 900mm

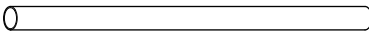

4x
Adj. Leg Tube 50Dia. x 2300mm



2x
Ladder Tube 50Dia. x 2950mm

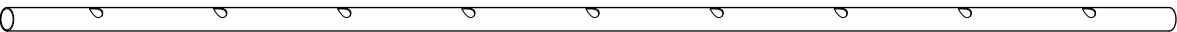

FITTINGS

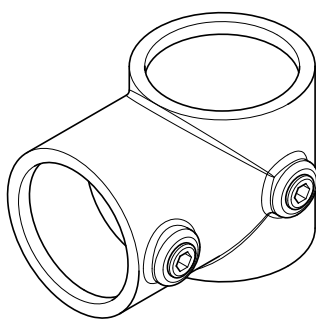

8x
Short Tee
D-101

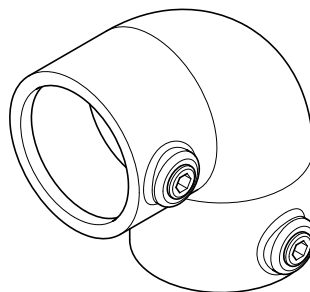

4x
Elbow
D-125

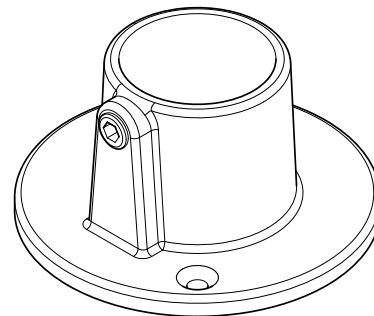

8x
Base Plate
D-131



8x
Peg

INVENTORY (CONTINUED)

HARDWARE

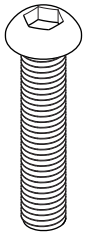

27x
M10 Bolt

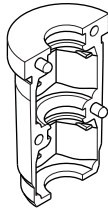

54x
Rung Insert

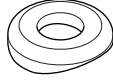

27x
Washer



54x
M10 Hex Nut

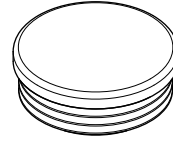

4x
Plastic End Cap



1x
Manufacture Sticker



4x
Height Sticker

COMPONENTS (NOT APPLICABLE)

One of the best things about a Funky Monkey Bar is the ability to add new equipment and accessories as your child and family grows. You can swap or add accessories to your existing frame, or add extra frames that will give you more versatility to attach equipment. Check out what we've got in store now at...

WWW.FUNKYMONKEYBARS.COM

ASSEMBLY INSTRUCTIONS - LADDER BAR ASSEMBLY

1 RUNG ASSEMBLY (X13)

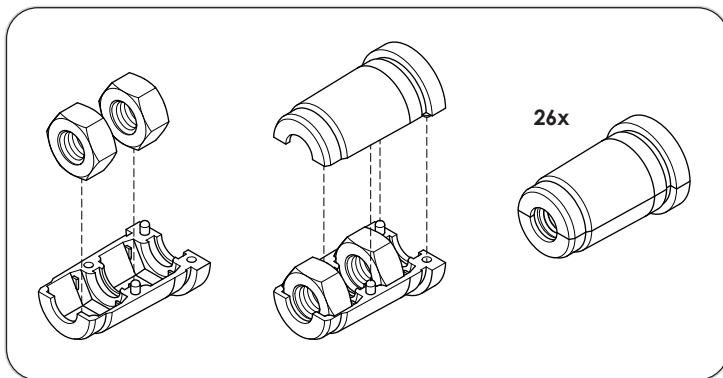

1. Assemble plastic rung inserts as shown above.

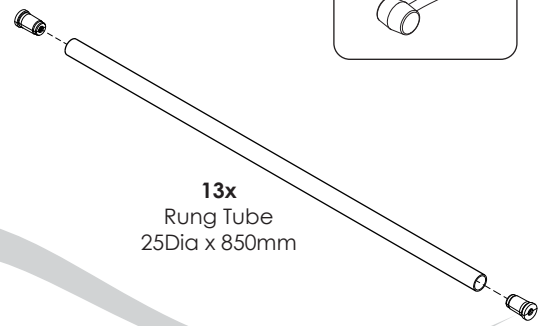

2. Push inserts into both ends of all rungs.

2 MONKEY BAR LADDER ASSEMBLY

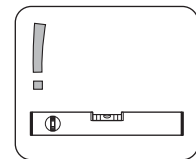
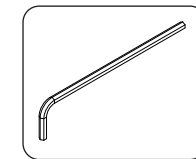
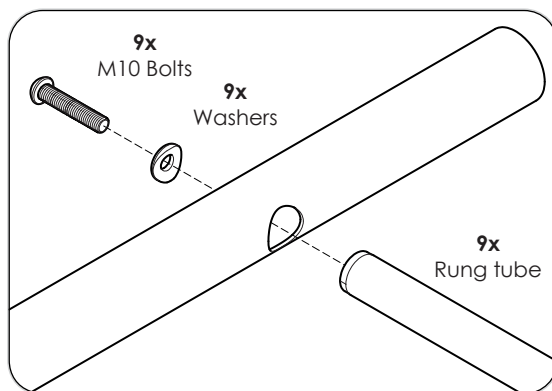

Hand tighten all bolts.

Assemble on flat surface.

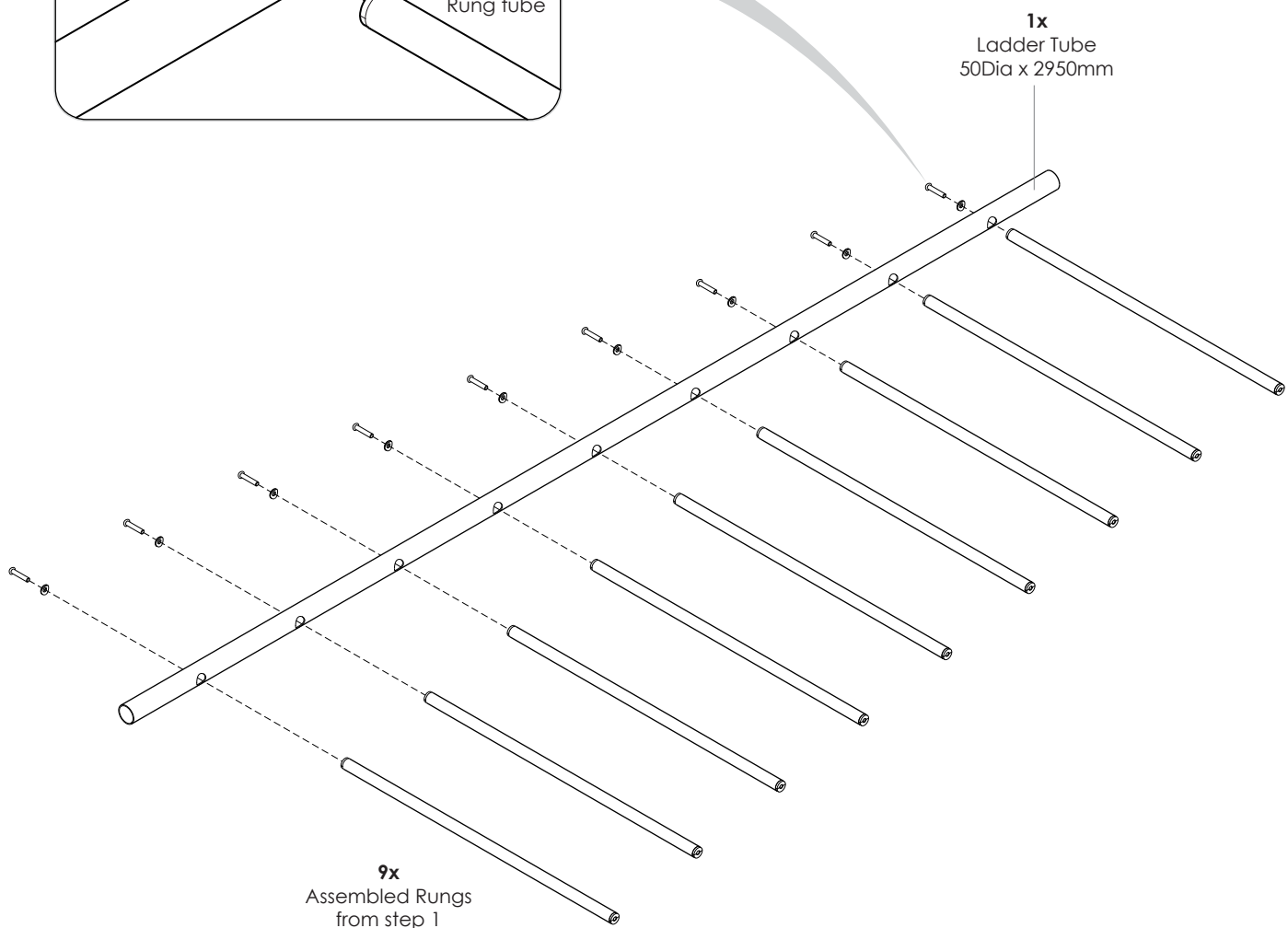

3 ATTACH SECOND LADDER TUBE

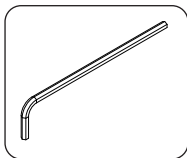

Hand tighten all bolts

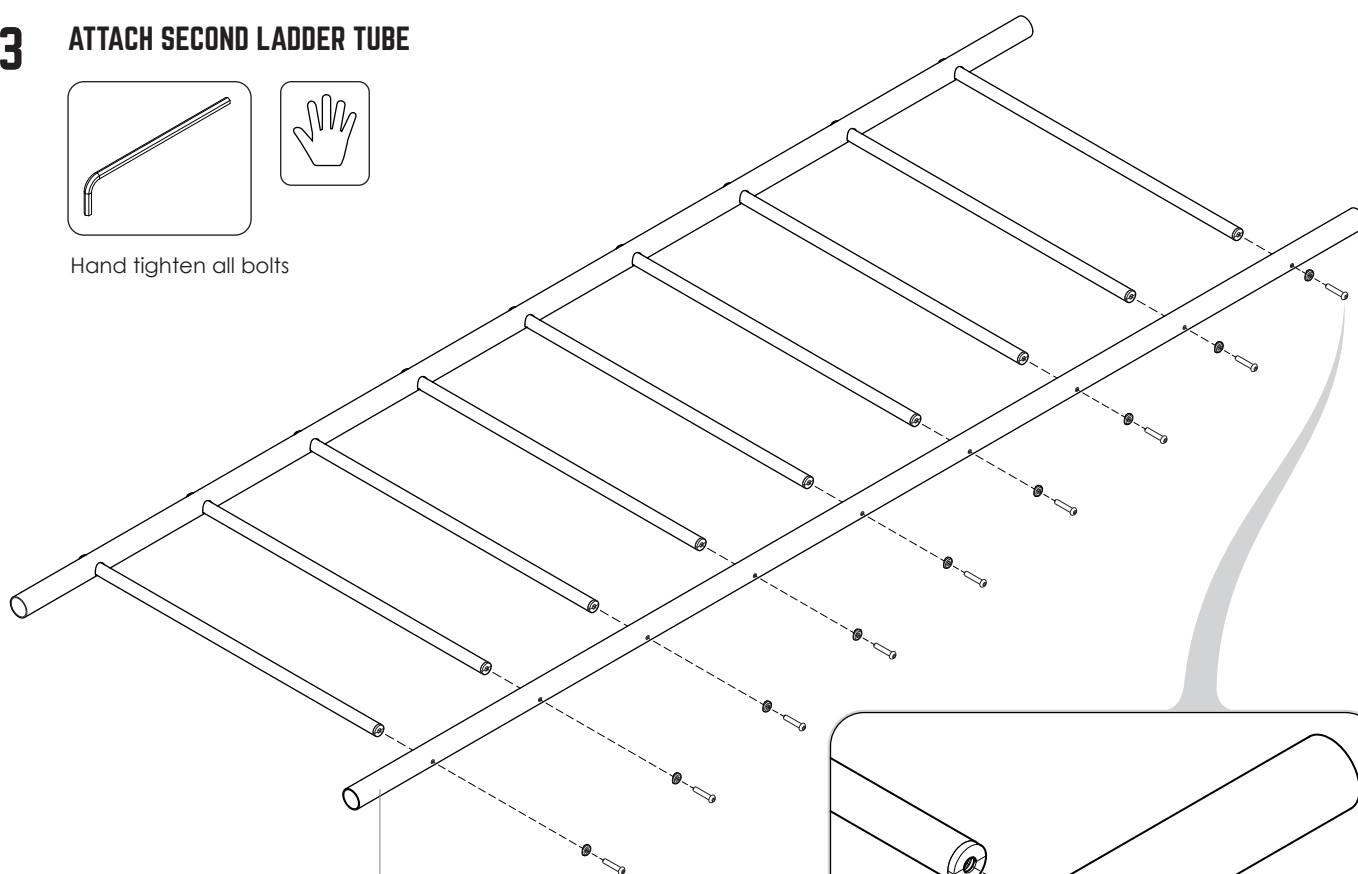

1x
Ladder Tube
50Dia x 2950mm

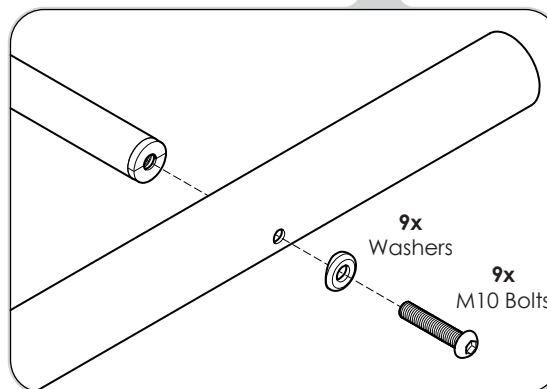

4 FIRMLY TIGHTEN ALL RUNG BOLTS.

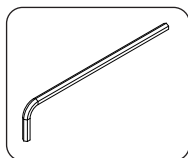

See page 5 for correct tightening method.

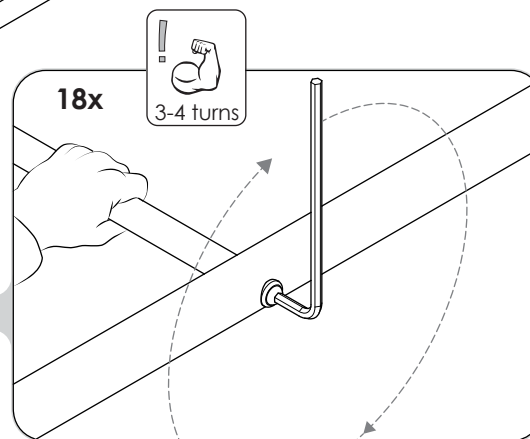
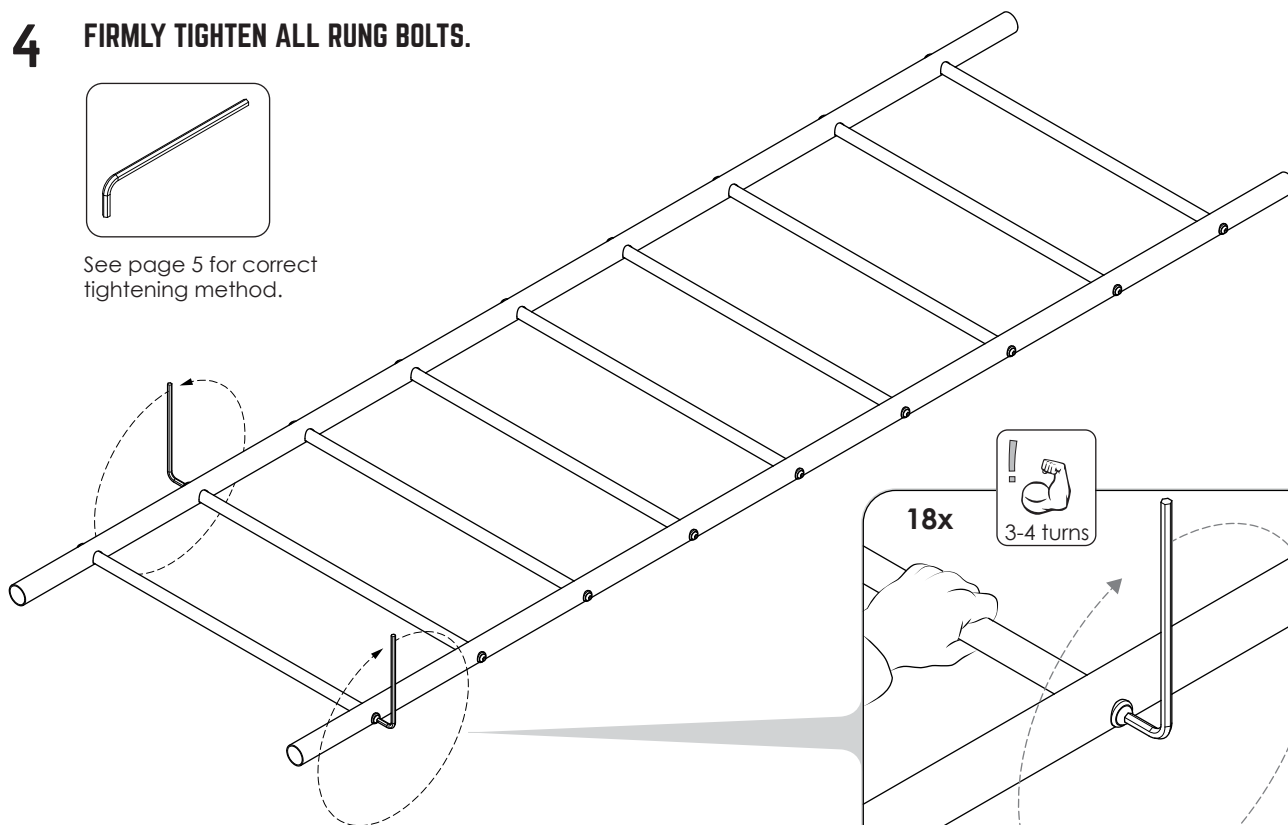

ASSEMBLY INSTRUCTIONS - LEG ASSEMBLY

5 LEG ASSEMBLY x 2

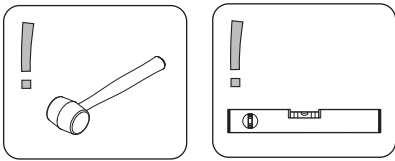

On a flat level surface insert plastic end caps into leg tubes.

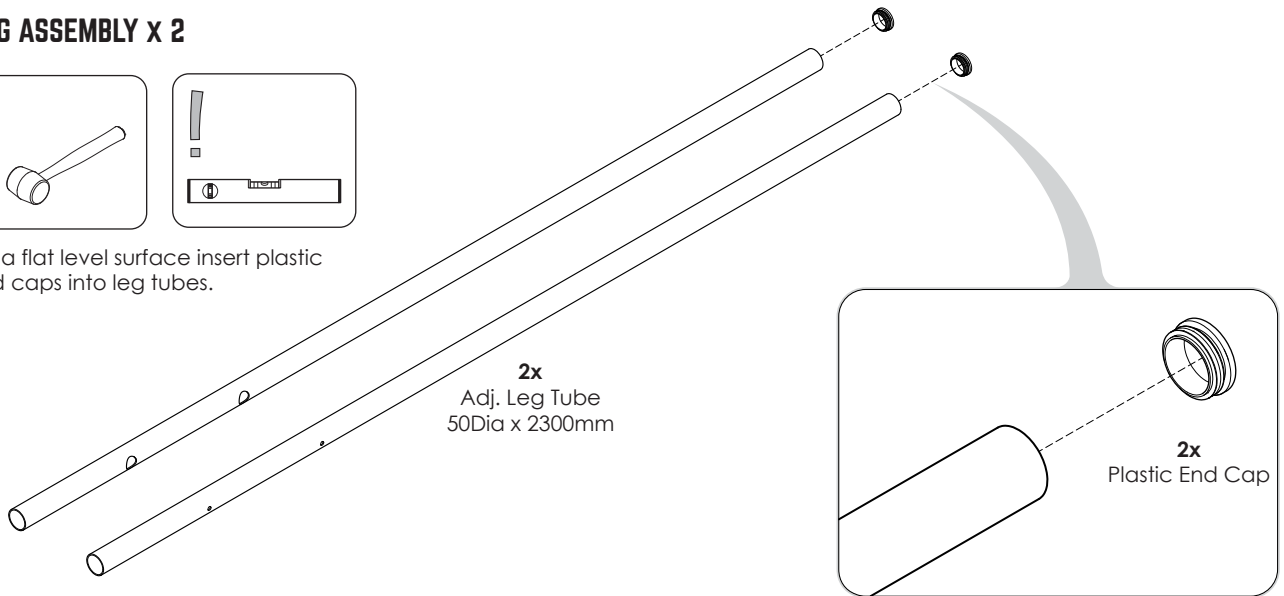

6 INSERT RUNGS

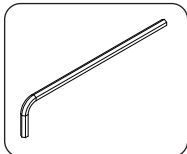

Tighten all bolts.

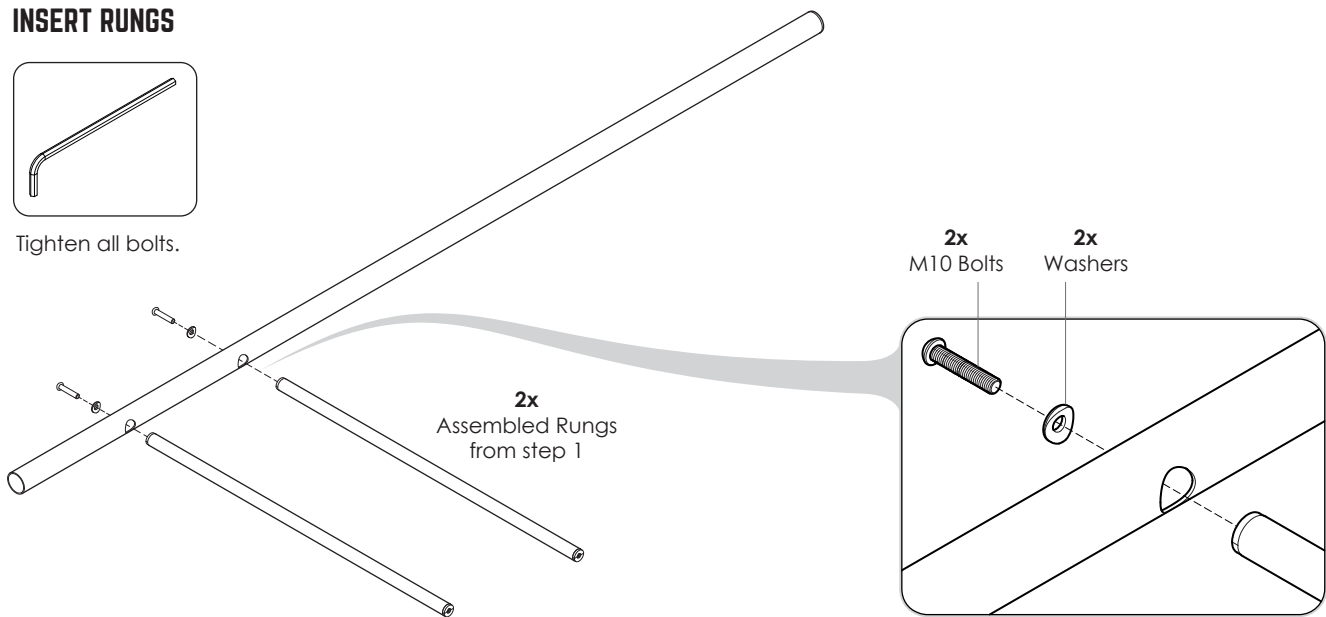

7 ATTACH SECOND LEG

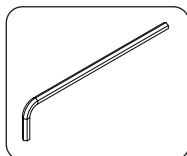

Tighten all bolts.

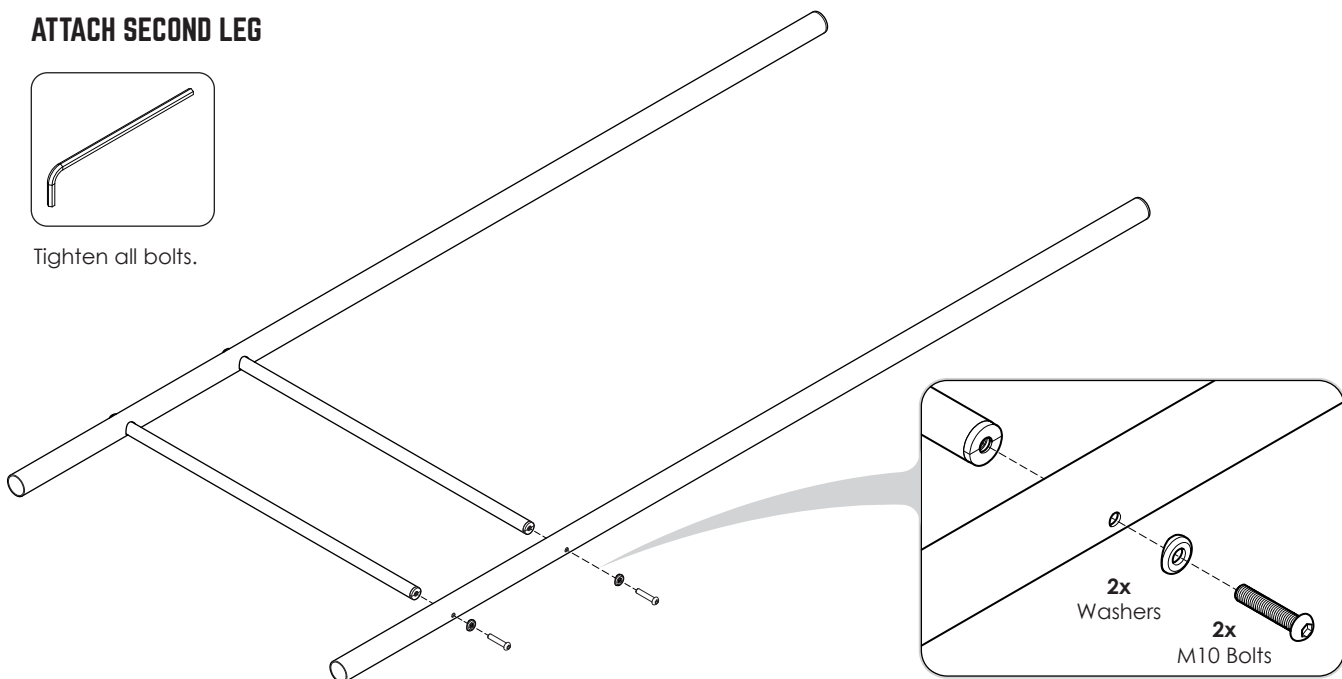

8 ATTACH BASE PLATES

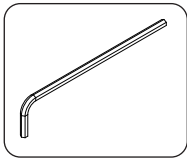

Tighten all grub screws.

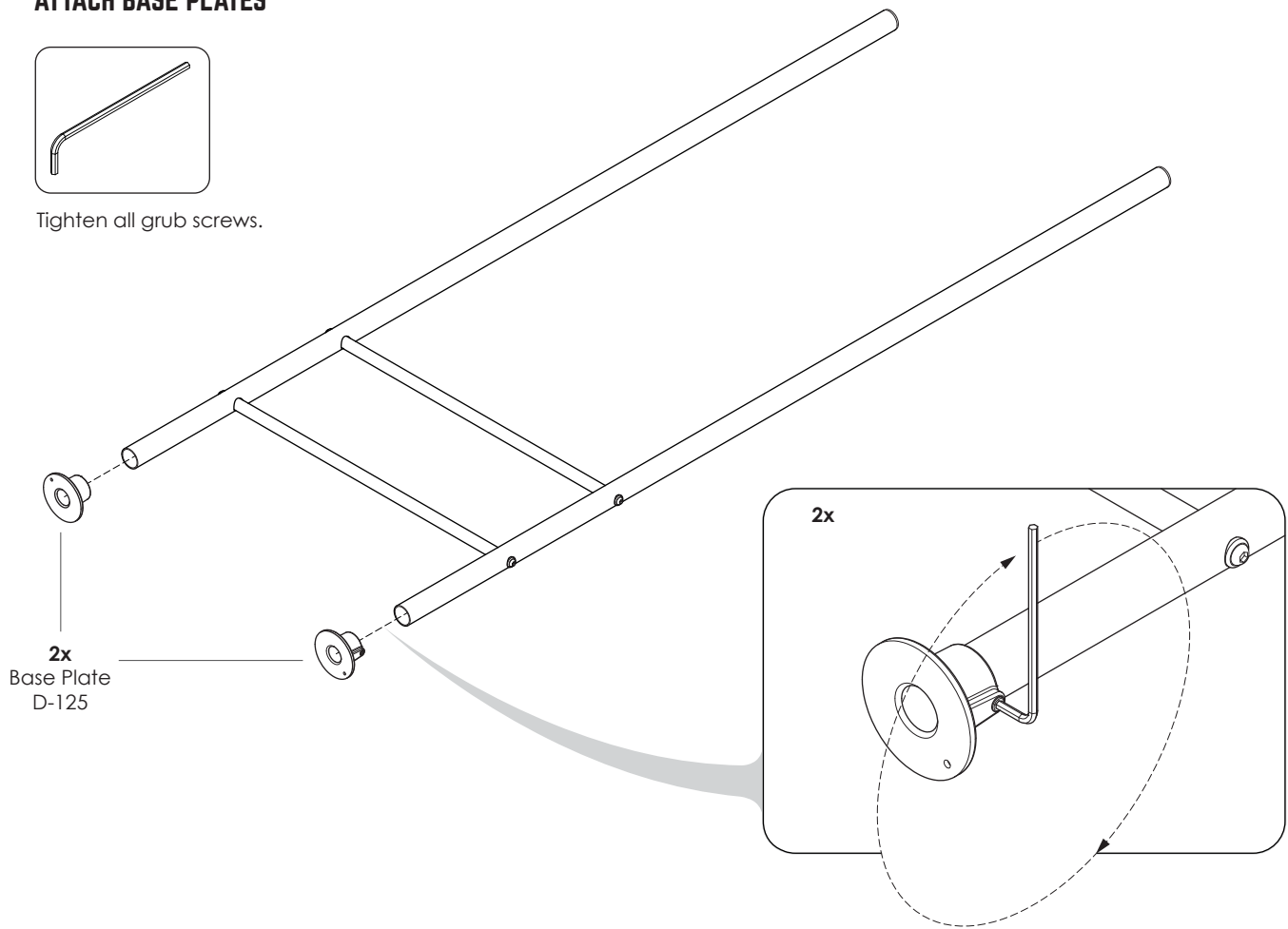

2x
Base Plate
D-125

9 SLIDE ON SHORT TEES

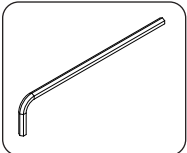

Hand tighten grub screws.
Temporary location.

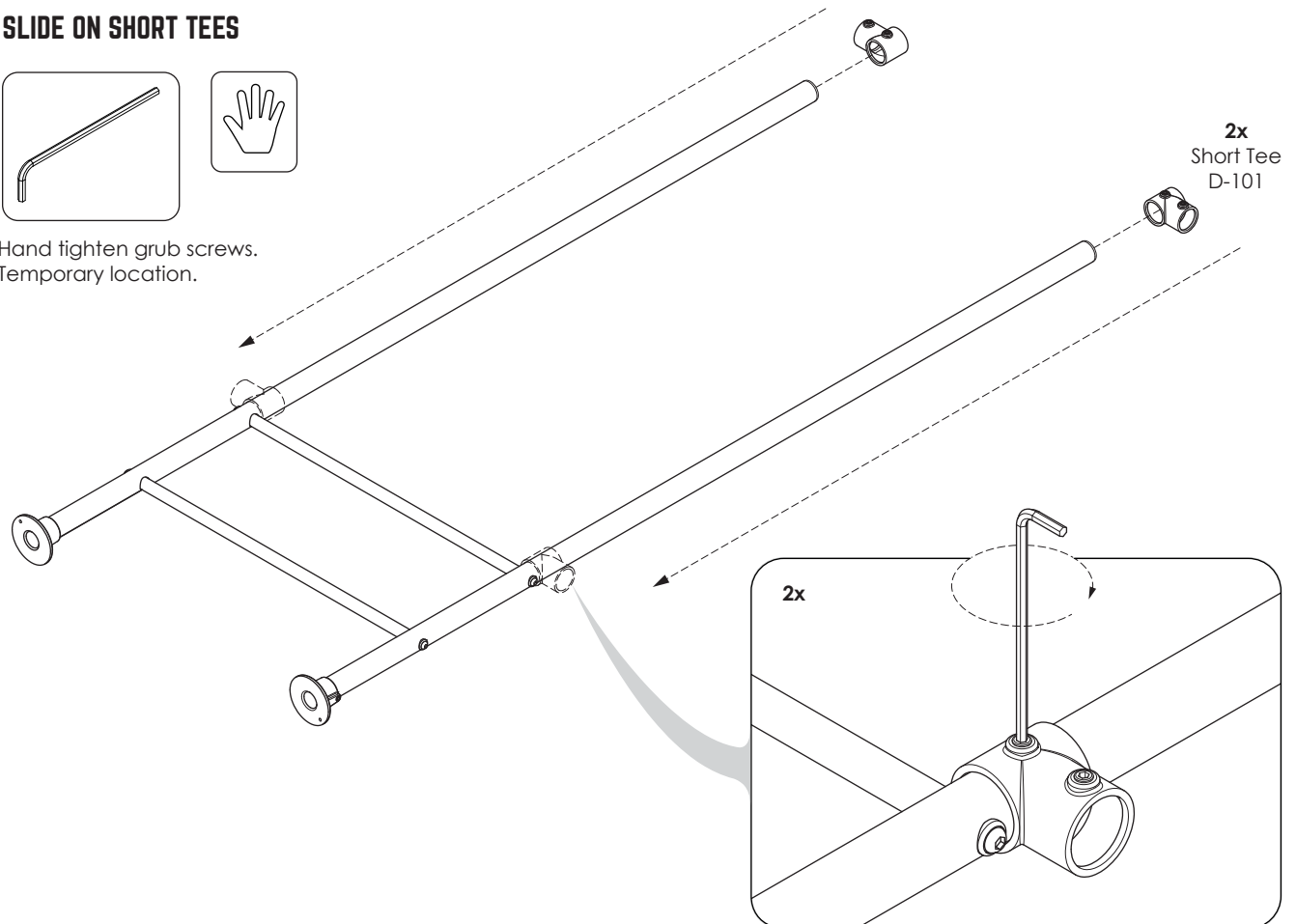

2x
Short Tee
D-101

10 APPLY HEIGHT STICKERS.

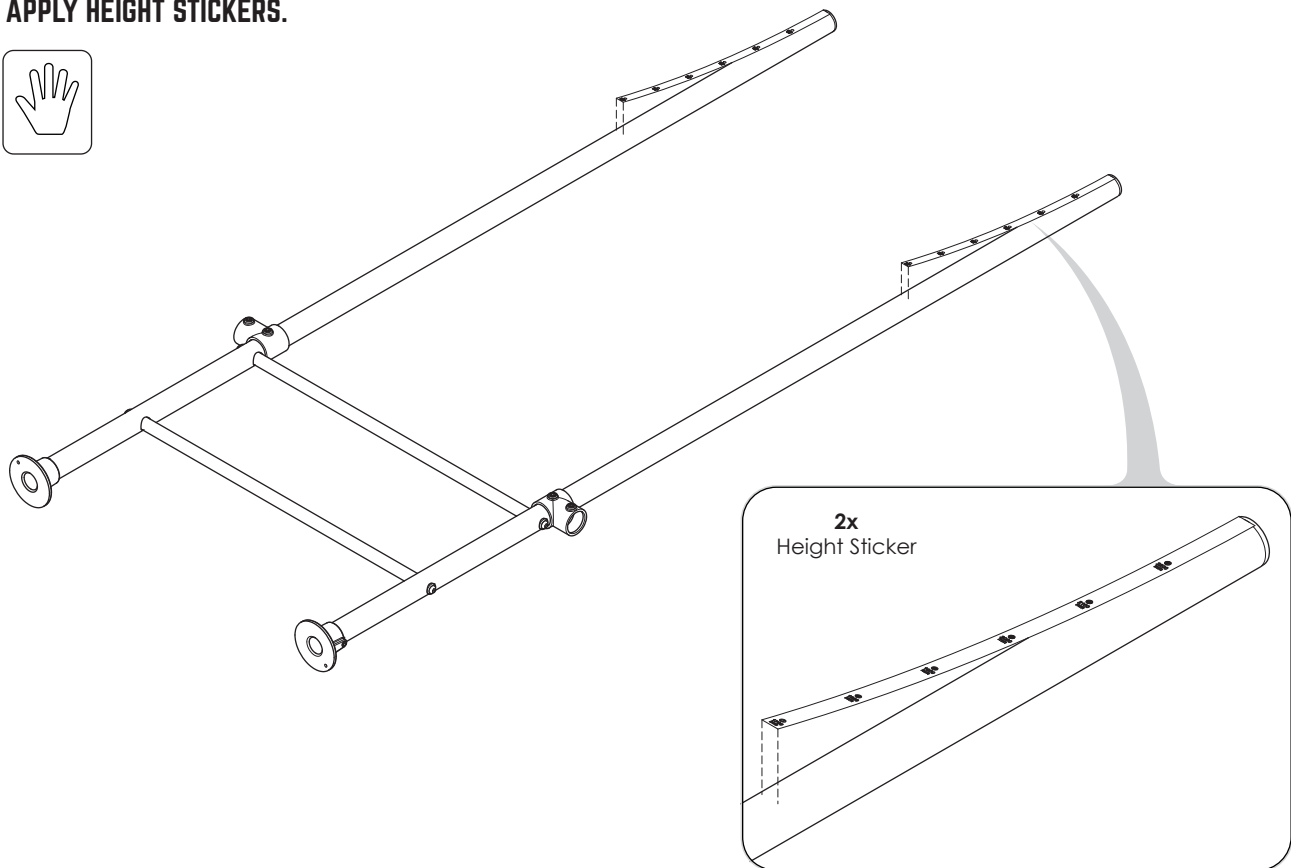

11 SET LADDER BAR HEIGHT.

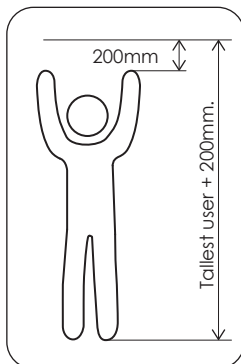

Good starting height is 100-200mm above reach.

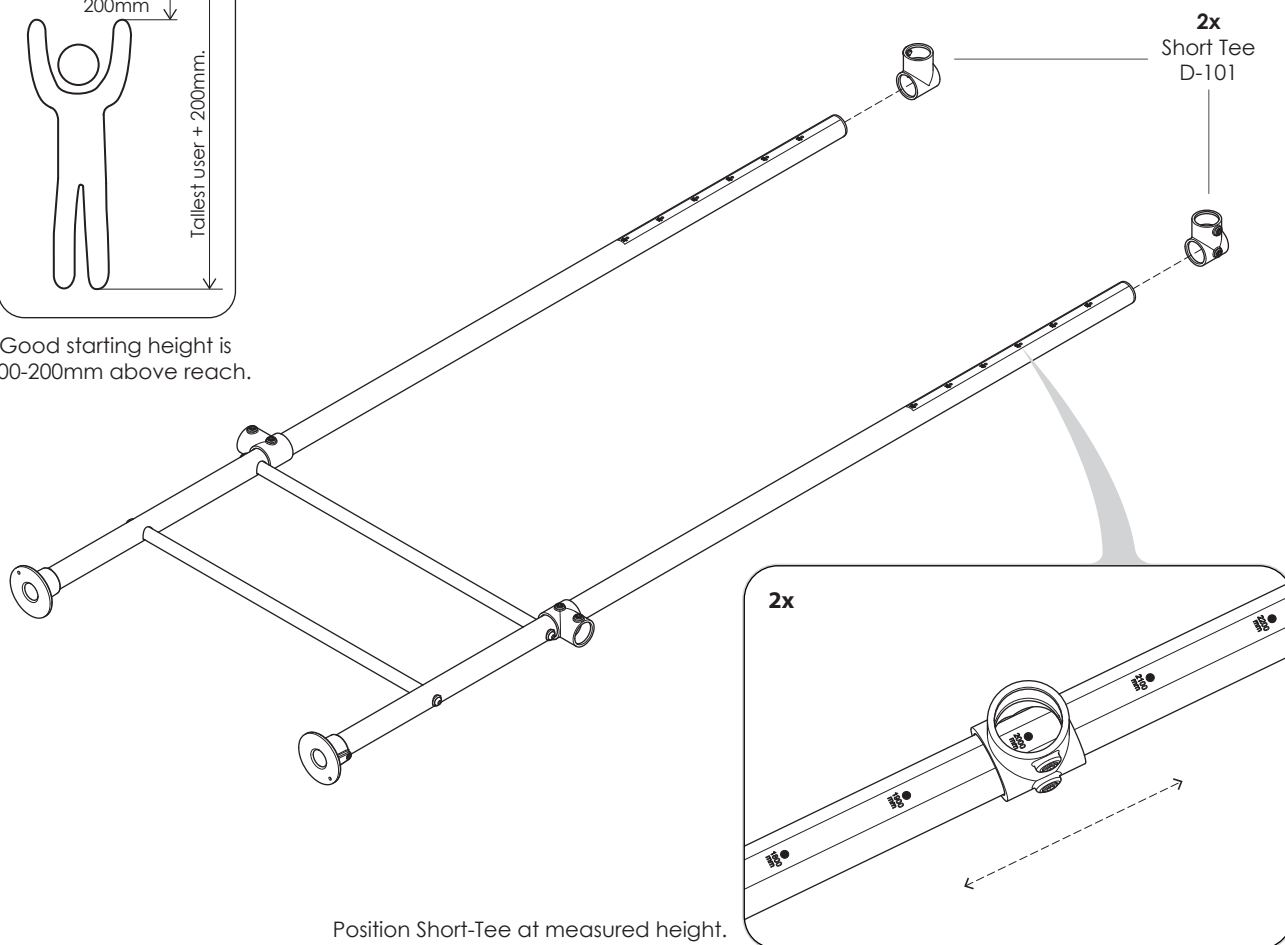

12 FIRMLY TIGHTEN ALL RUNG BOLTS & GRUB SCREWS.

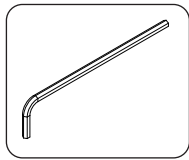

8x

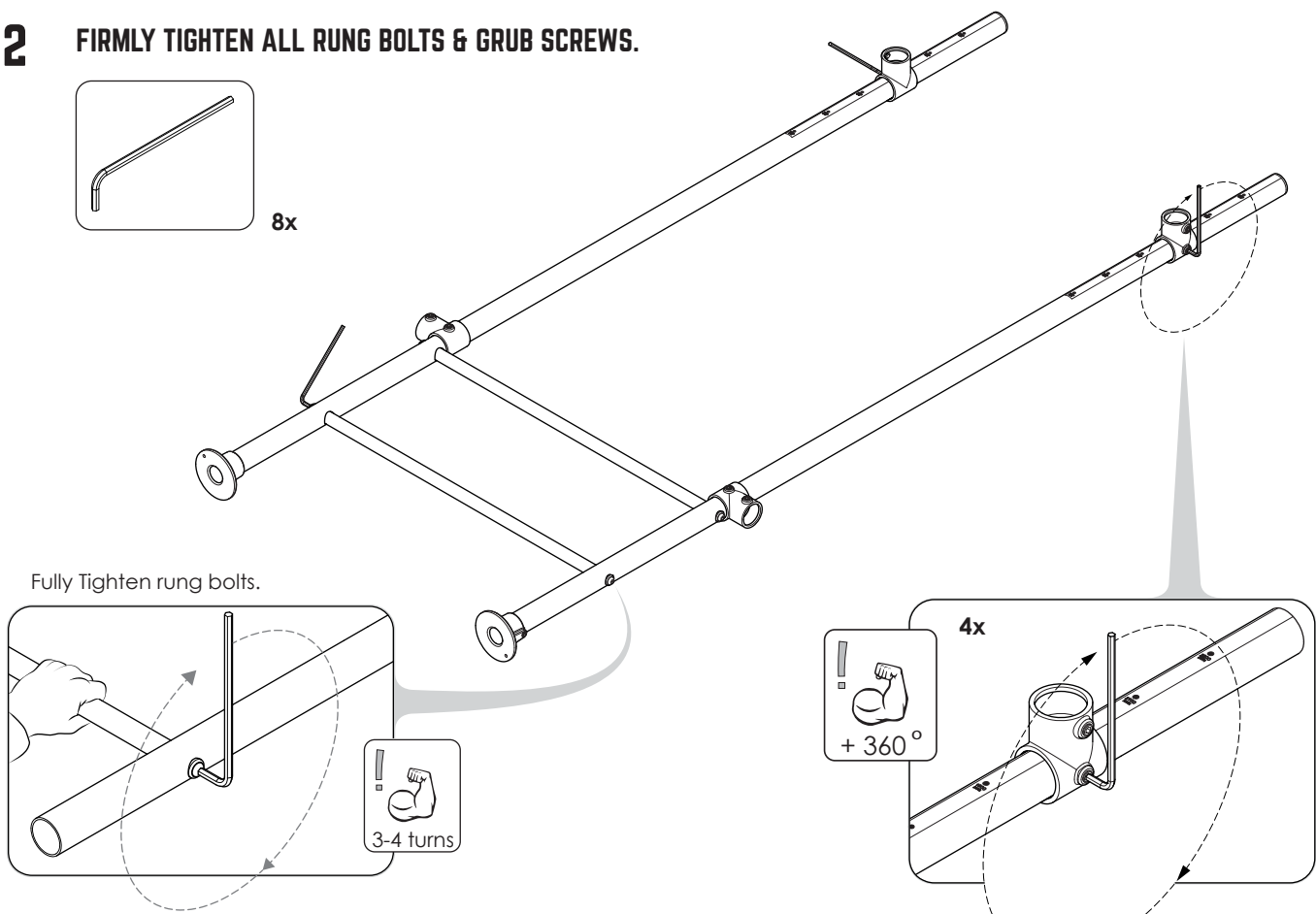

13 REPEAT STEPS 5 -12 FOR SECOND PAIR OF LEGS.

14 LEG ASSEMBLY X 2.

Standing up with top tees facing each other.
Check all grub screws are fully tightened.
Leave lower short tees hand tight only.

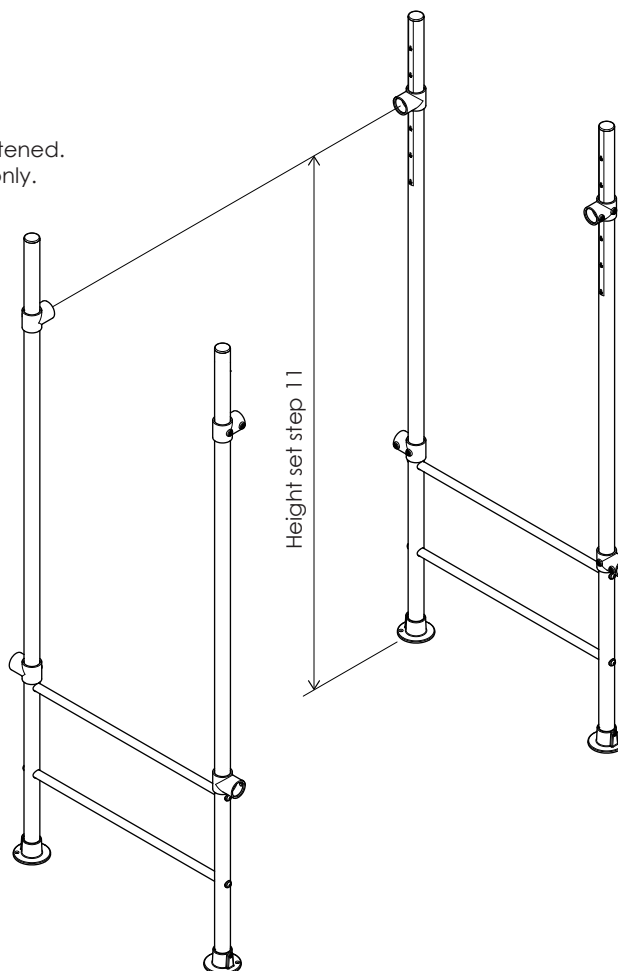

ASSEMBLY INSTRUCTIONS - TWIRLY WHIRLY BAR ASSEMBLY

15 ASSEMBLE VERTICAL TWIRLY TUBE

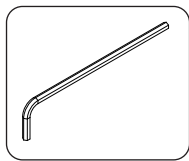

Tighten all grub screws.

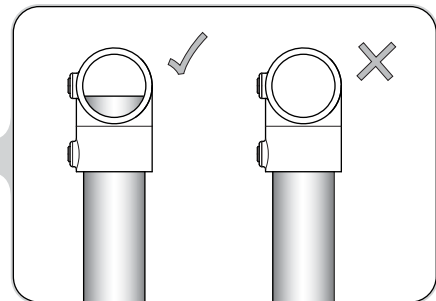
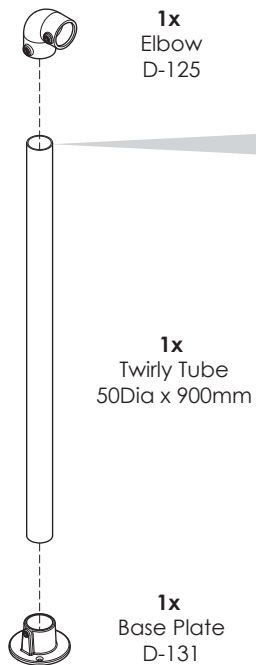

Insert Twirly Tube fully into Elbow.

16 ATTACH HORIZONTAL TWIRLY TUBE

Fully insert twirly tube then firmly tighten all grub screws.

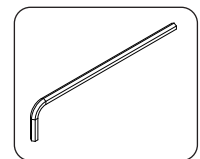
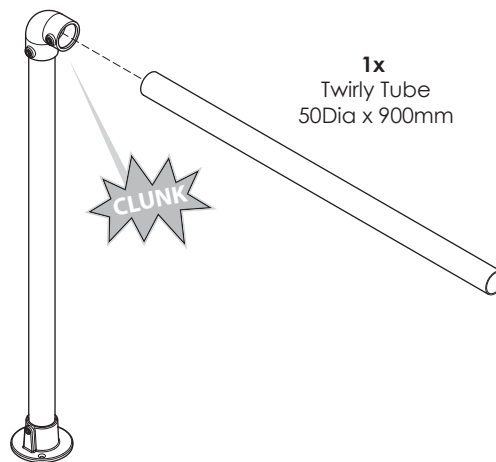
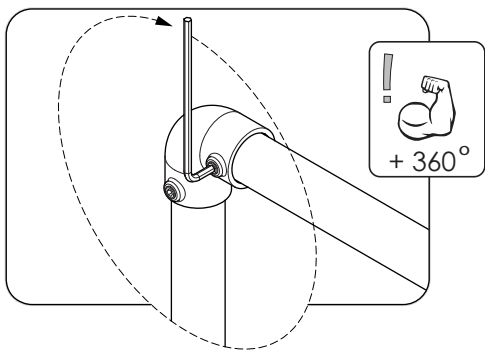

17 REPEAT STEPS 15 -16 FOR 3 MORE TWIRLY WHIRLY BARS.

18 TWIRLY WHIRLY BAR x4

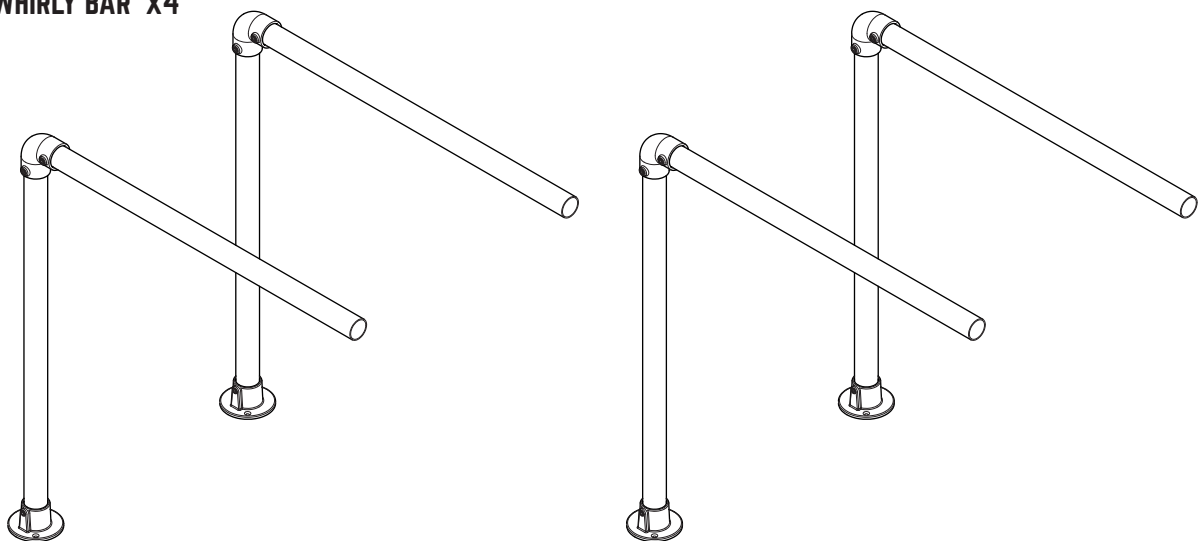

19 FLIP LEGS OVER

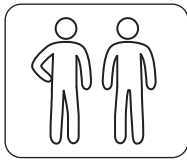

For the following step the legs should be flipped over & attached one at a time.

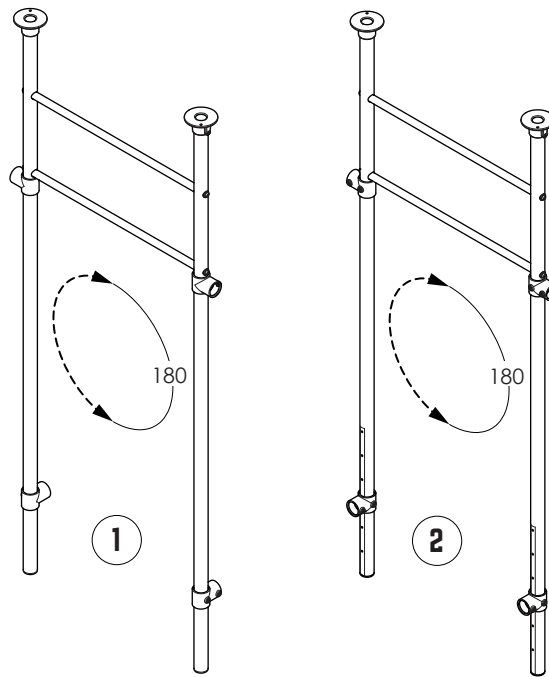

20 ATTACH 2X LEGS TO LADDER

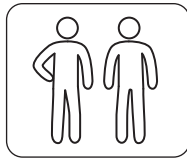
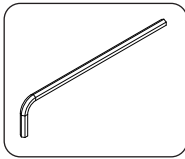

Using two people assemble 2x legs and ladder bar assembly from step 4.

1. Attach first set of legs ① - tighten all grub screws.
2. Attach second set of legs ② - tighten all grub screws.

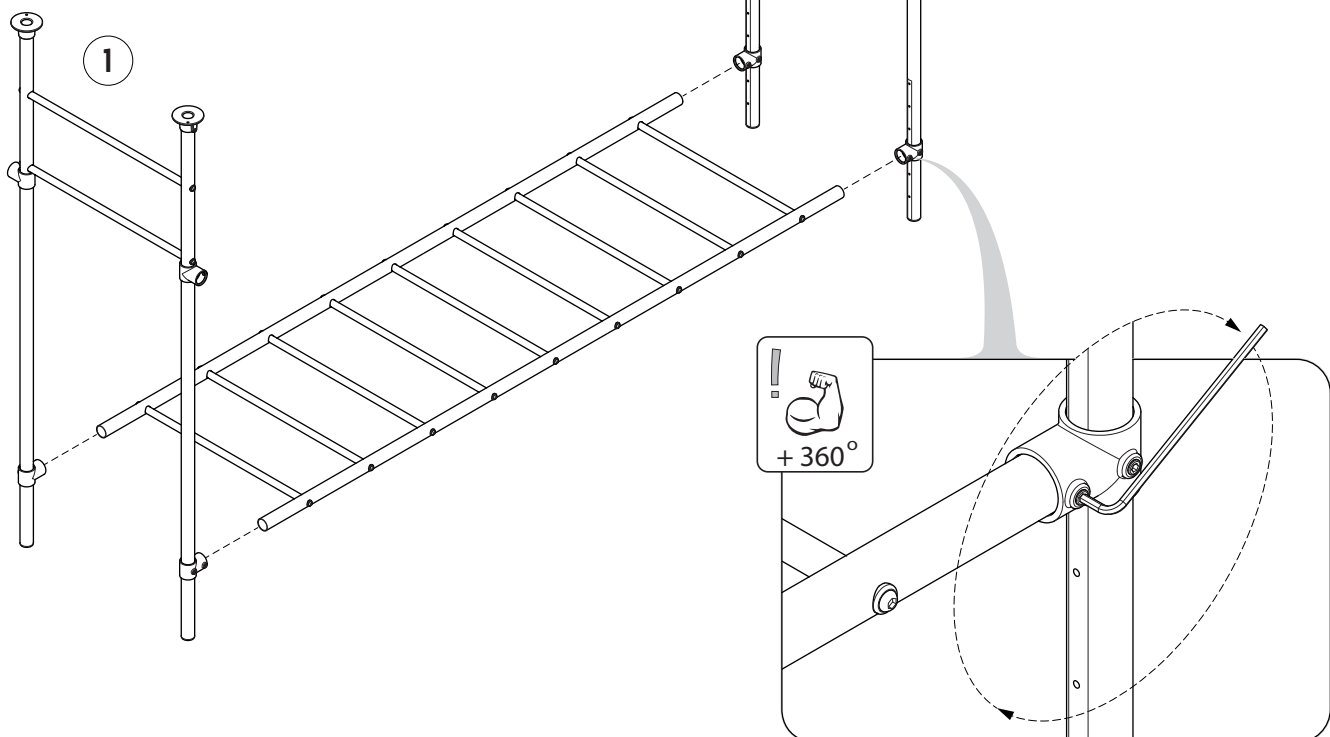

21 FLIP ASSEMBLY OVER

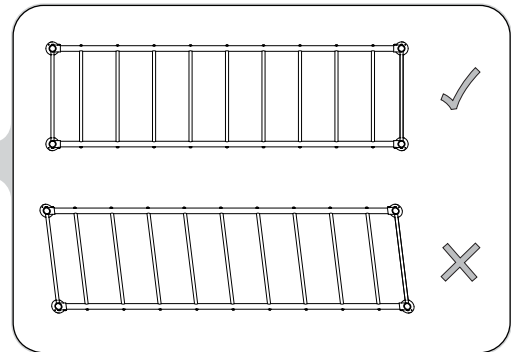
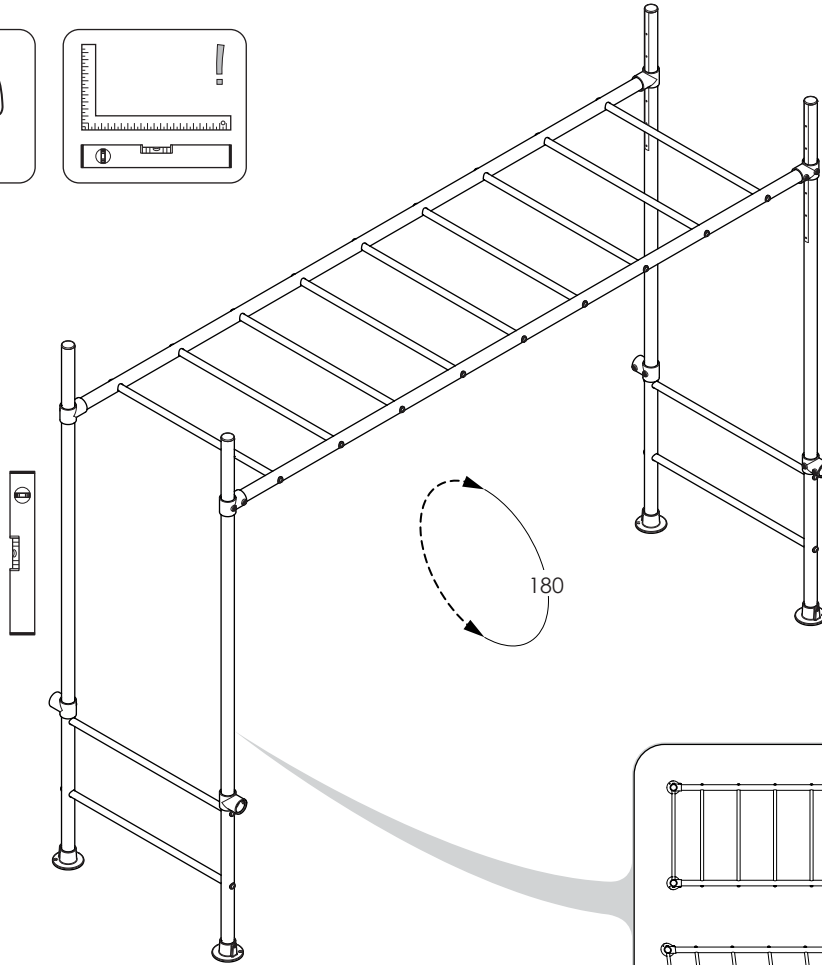
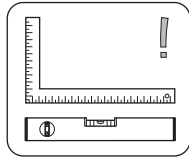
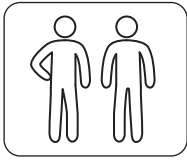

CRITICAL : ENSURE YOUR FRAME IS 100% SQUARE AND LEVEL (AS PER PAGE 6) BEFORE MOVING ONTO THE REST OF THE ASSEMBLY

22 SECURE TO GROUND

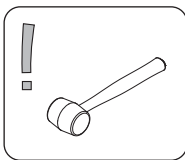

Select suitable location.
Hammer in pegs x4.

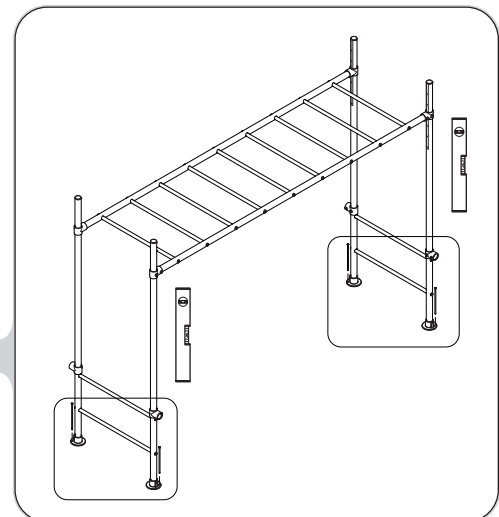
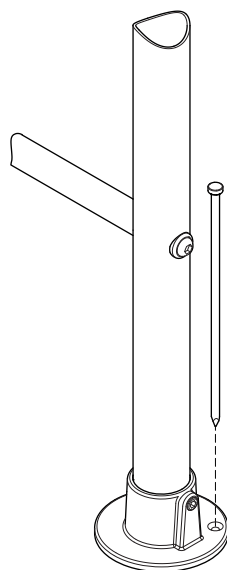

23 SELECT A CONFIGURATION OPTION

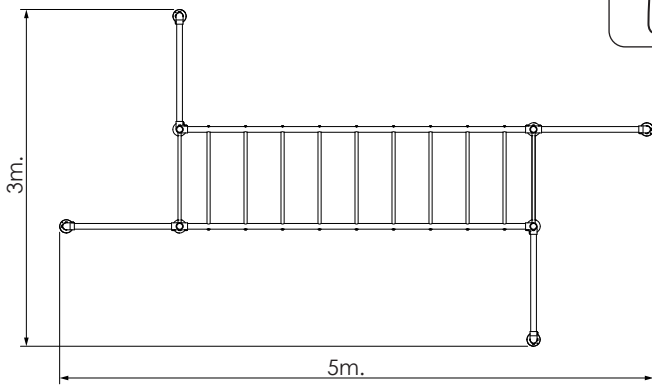

OR

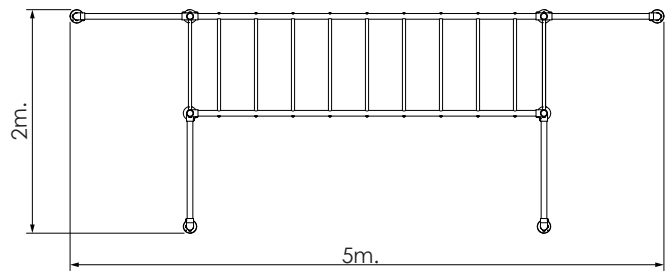

24 ATTACH TWIRLY WHIRLY BARS X4

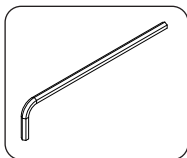

Adjust height of short tees to align with horizontal twirly whirly bars.

Tighten all grub screws fixing twirly whirlys to legs.

4x Twirly whirly bars from step 18.

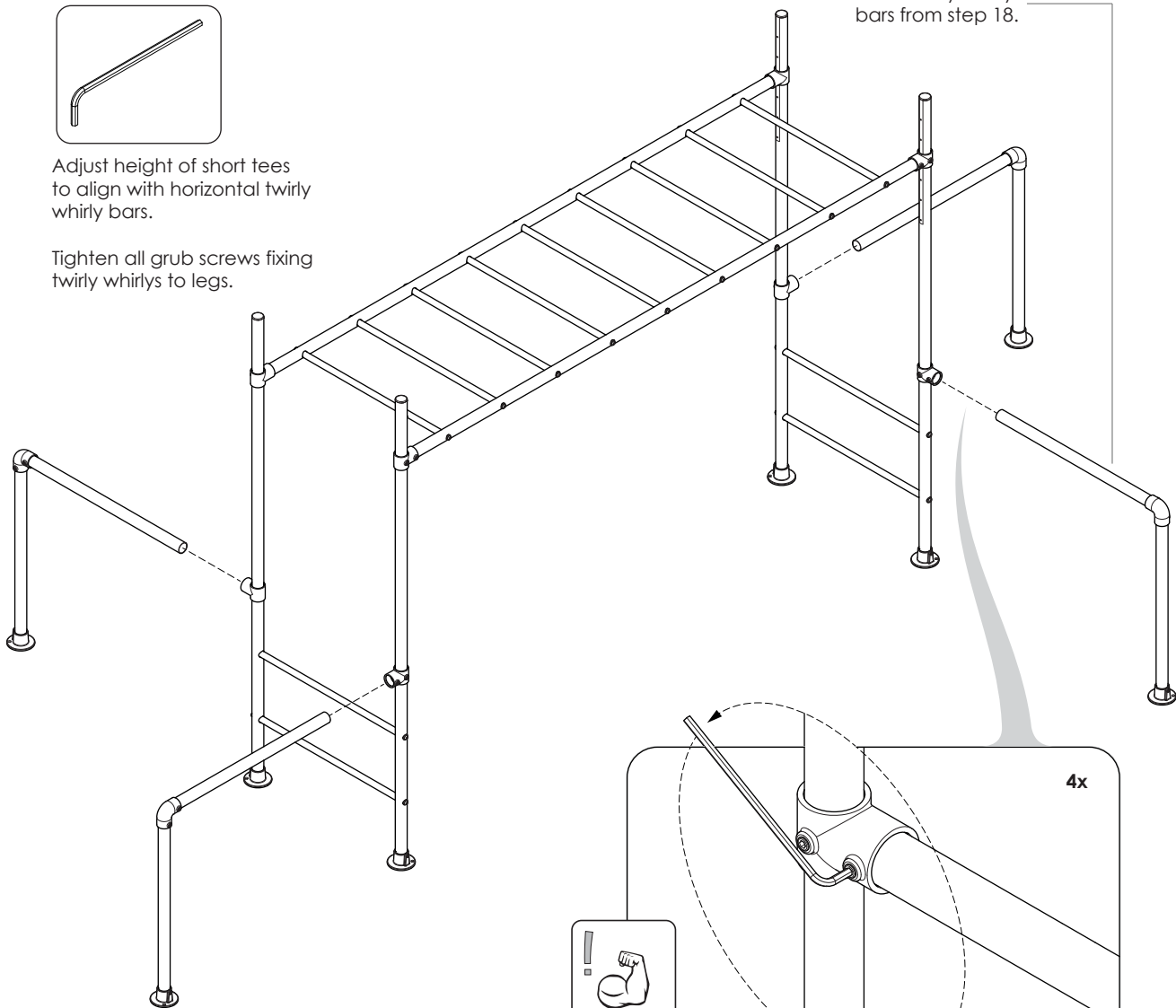

Tighten all grub screws.

25 LOAD YOUR TWIRLY WHIRLY BARS x2

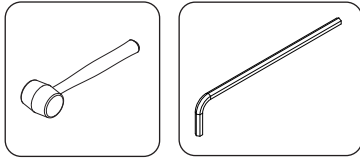

To reduce movement in your frame load your twirly whirly bars as follows.

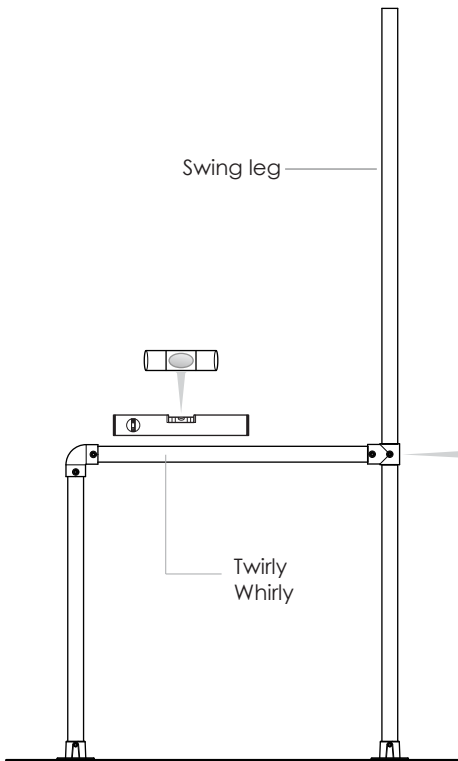

1. Ensure twirly whirly is level and square & swing leg is pegged down.

2. Loosen the grub screw fixing the short tee to the swing leg.

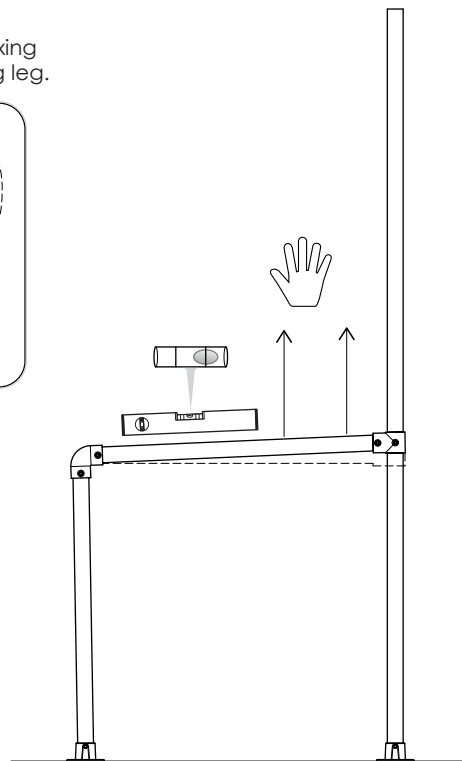
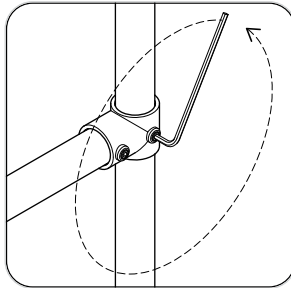

3. Pull upwards on the twirly whirly bar to make a slight angle. (Half a bubble off center on the level)

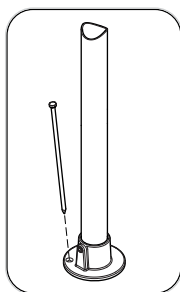

4. Peg down base plates on twirly whirly.

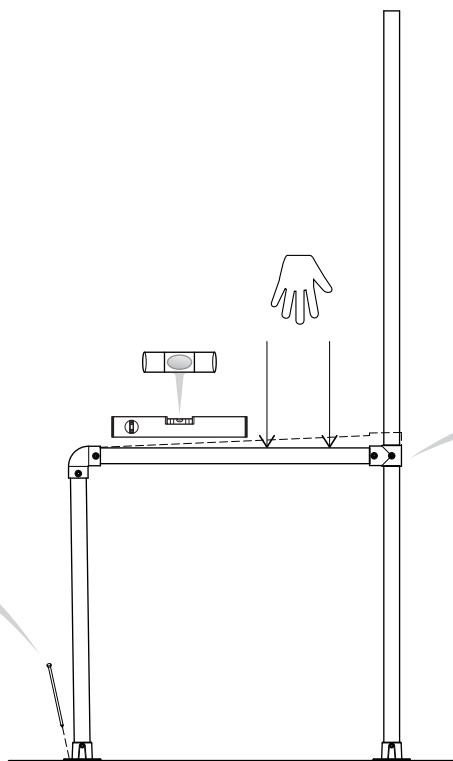

5. Push down on the twirly whirly bar until horizontal bar is level.

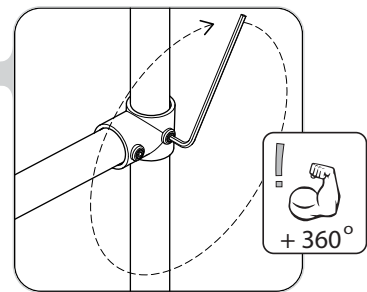

6. Tighten grub screw fixing the short tee to the swing leg tube. Apply to all twirly whirlys.

REFER TO VIDEO SECTION OF WEBSITE [HTTP://WWW.FUNKYMONKEYBARS.COM/PAGES/VIDEOS](http://www.funkymonkeybars.com/pages/videos)

STICKER PLACEMENT GUIDE

26 ATTACH STICKERS TO FRAME



2x
① Logo Sticker



1x
② Manufacture Sticker



1x
③ Warning Label Sticker



2x
④ Australia Made Sticker



4x
⑤ Height Marker Sticker

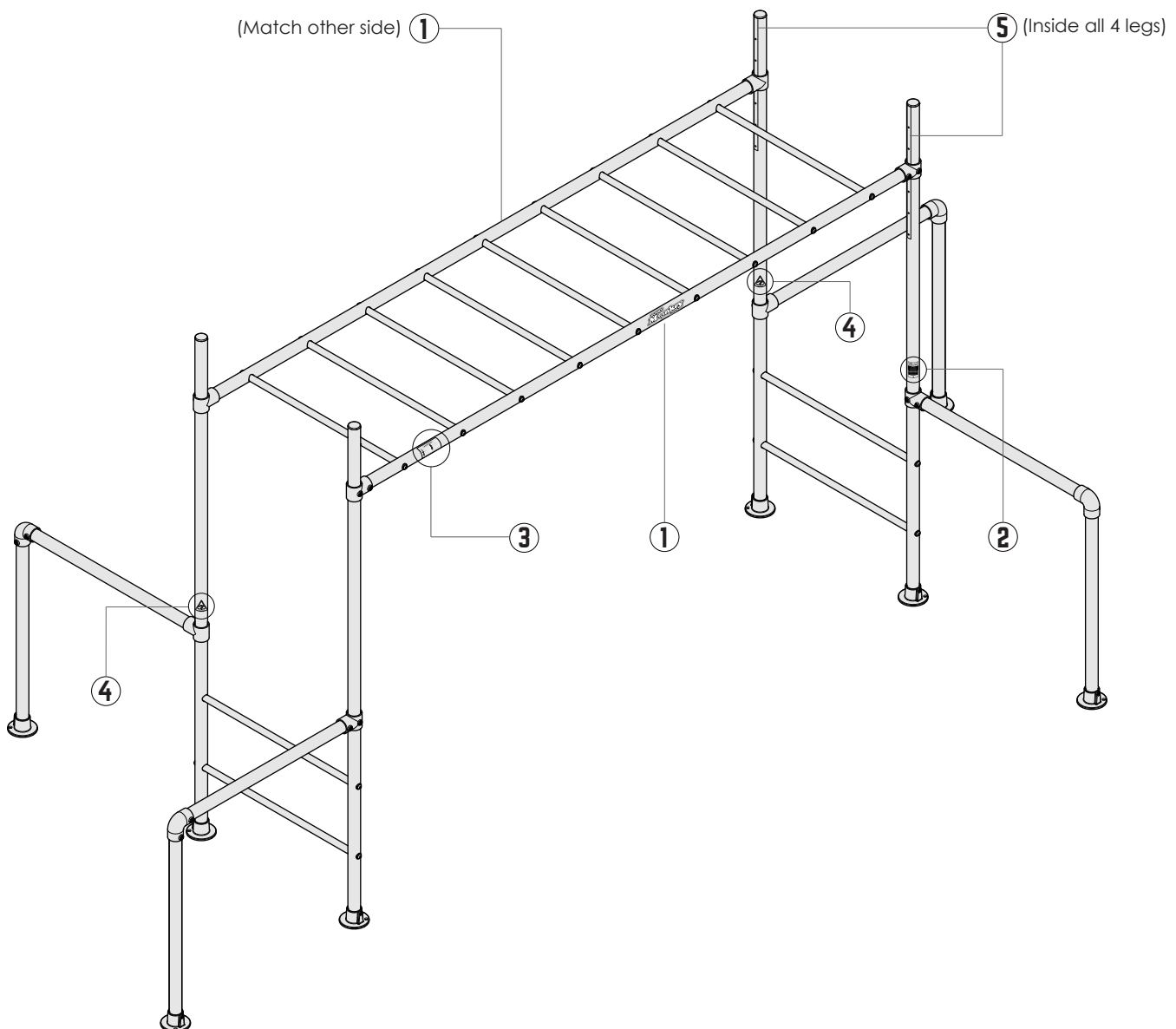

27 FINAL CHECKS

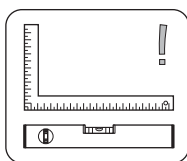
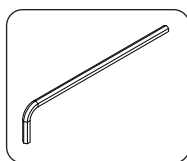

1. Ensure frame is square and level.
2. Firmly tighten all grub screws and bolts.
3. All base plates are pegged down.

NOTES

28 MAINTENANCE.

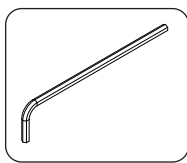
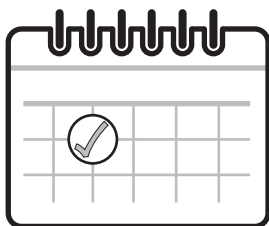

At the beginning of each heavy play session (especially a party) and twice a month during play season ensure;

1. Tighten all hardware - grub screws, nuts and bolts.
2. Pegs are in place and fully secure.
3. Lubricate all metallic moving parts (trolley and swing hooks.)
4. Ensure your frame is level and square.

FAILURE TO DO SO COULD RESULT IN SERIOUS INJURY OR DEATH.

**FOR MORE INFORMATION AND ASSEMBLY TIPS
PLEASE REFER TO OUR WEBSITE VIDEO INSTRUCTION SECTION AT
[HTTP://WWW.FUNKYMONKEYBARS.COM/PAGES/VIDEOS](http://www.funkymonkeybars.com/pages/videos)**

29 HAVE FUN





ABN 72 164 496 520



1300 912 198



info@funkymonkeybars.com



www.funkymonkeybars.com



9 Cutting Way,
Yangebup WA 6164



WE ARE SOCIAL MONKEYS



Australian Government
IP Australia

All Funky Monkey Bars® designs are registered and protected under IP Australian certification.