

FUNKY Monkey bars[®]

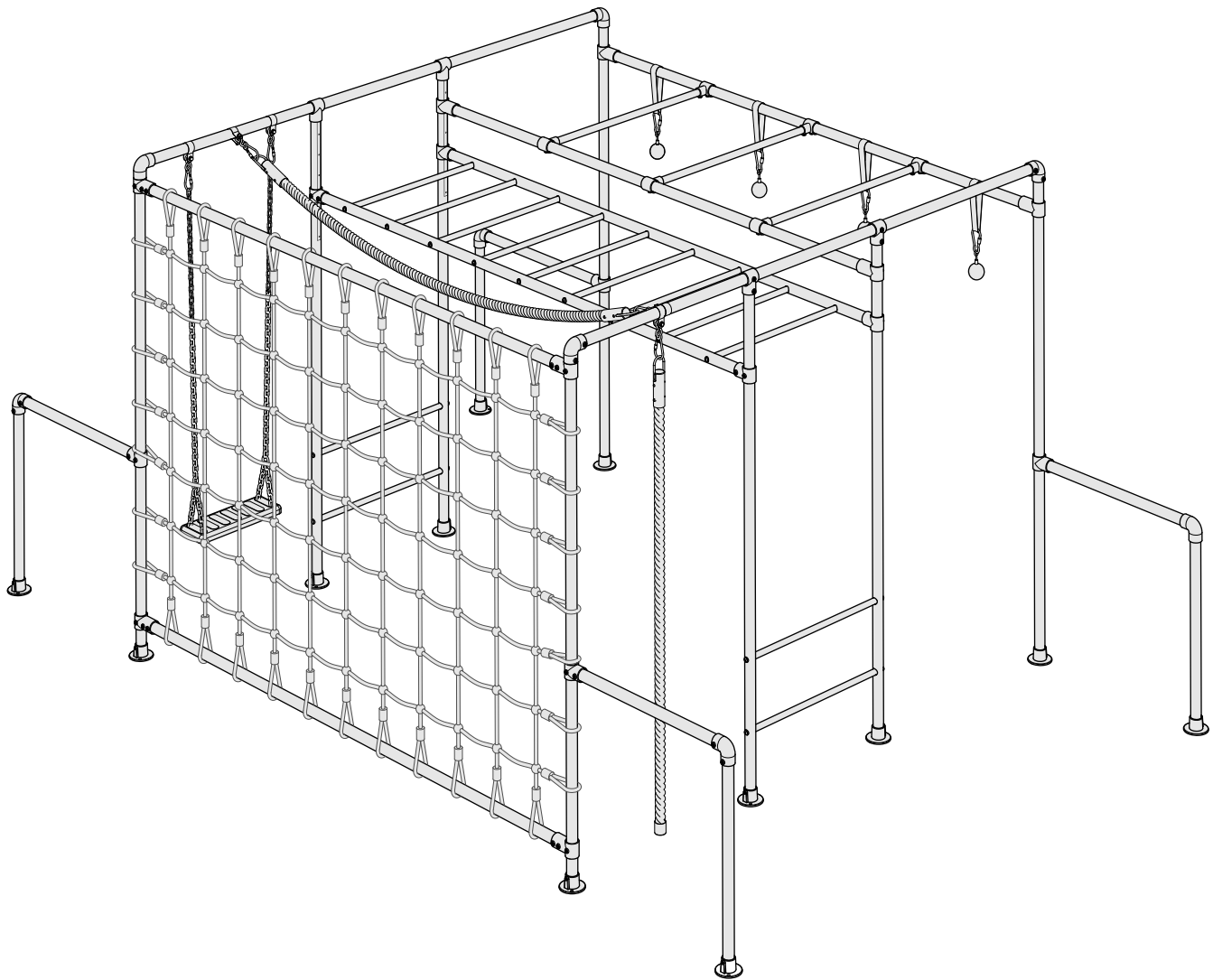

THE NEW NINJA ASSEMBLY INSTRUCTIONS

CONTENTS

Warnings	Page 1
Load Rating	Page 3
Dimensions	Page 4
Assembly Tips	Page 5
Inventory	Page 7
Assembly Instructions	Page 10
Ladder Bar Assembly	Page 10
Leg Assembly	Page 12
Main Monkey Bar Assembly	Page 16
Lache Accessories Bar Assembly	Page 18
Swing Bar Assembly	Page 20
Swing Leg Assembly	Page 22
Cargo Net Assembly	Page 25
Twirly Whirly Bar Assembly	Page 28
Load Twirly Whirly Bars	Page 30
Sticker Placement Guide	Page 32
Maintenance	Page 33

WARNING

PLEASE CAREFULLY READ ALL INFORMATION CONTAINED IN THIS ASSEMBLY MANUAL BEFORE YOU INSTALL AND USE YOUR FUNKY MONKEY BARS®.

SAFETY NOTICE

1. Any person handling or using the Funky Monkey Bars® products must follow the instructions as described in this document. The person in charge of assembling and using the equipment must ensure that the recommendations for use given in this document are seen by all users.
2. Only use the Funky Monkey Bars® after they have been fully assembled and after checking that the fittings are tightened properly (*refer to page 5 - Correct Tightening Method*).
3. DO NOT install your Funky Monkey Bars® over concrete, asphalt, packed earth, wood decking or any other hard surface. A fall onto a hard surface can result in serious injury or death.
4. Inspect all grub screws, bolts and nuts at the beginning of each play session to ensure your Funky Monkey Bars® are tight and secure.
5. Ensure all tubes are fully inserted into fittings until you hear the magic "CLUNK" sound.
6. Ensure your Funky Monkey Bars® are properly secure at ALL times. Pegs are in place and inserted fully into the ground.
7. DO NOT exceed the maximum load/weight limit as recommended by Funky Monkey Bars®.
8. Children should be supervised by an adult at all times.
9. Installing a gym/crash mat under the fall zone area of your Funky Monkey Bars® would be recommended for children learning this new skill. This will reduce the chance of injury and build the child's confidence while they build strength and master the skill.
10. Ensure you have thoroughly read your assembly and installation instructions and viewed our on-line installation videos at <https://www.funkymonkeybars.com/blogs/installation-maintenance-videos>
11. DO NOT climb, sit or stand on top of the monkey bar (horizontal ladder) section.
12. DO NOT jump from the top of any section of the monkey bar.
13. DO NOT use your Funky Monkey Bars® when wet as the steel will be slippery.
14. DO NOT attach items to your frame that are not designed specifically to be used with Funky Monkey Bars®, especially lower quality products that have not been approved by Funky Monkey Bars®.
15. Ensure the height of your Funky Monkey Bars® (horizontal ladder) are set at a level that is age appropriate.
16. DO NOT install your Funky Monkey Bars® over or near objects that could interfere with users in an unsafe way. Maintain a clear area around your Funky Monkey Bars®.
17. DO NOT use your Funky Monkey Bars® while under the influence of drugs and alcohol.
18. Wear clothing free of drawstrings, hooks, loops or anything that could get caught while using your Funky Monkey Bars® and result in entanglement and/or strangulation.

ASSEMBLY

1. Keep small children away from the Funky Monkey Bars® during assembly.
2. Do not attempt to use the Funky Monkey Bars® until it is completely assembled and every fitting is tight and secured.
3. Installation typically takes 3-4 hours to complete. Two people are recommended for assembly.
4. Ensure all fittings are tightened to the correct tightening method as described on page 5.
5. Assembly should be carried out on clean, dry, level surface

Please refer to the video section on the Funky Monkey Bars® website for more handy tips and assembly instructions at <http://www.funkymonkeybars.com/pages/videos>

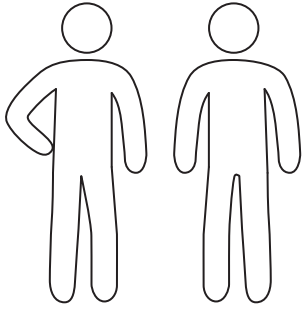

Assembly requires 2 adults.

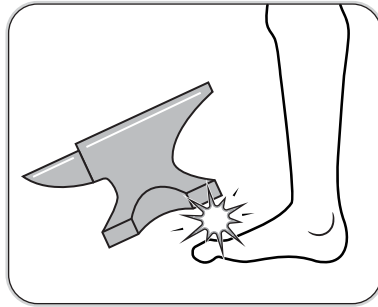

Heavy items !

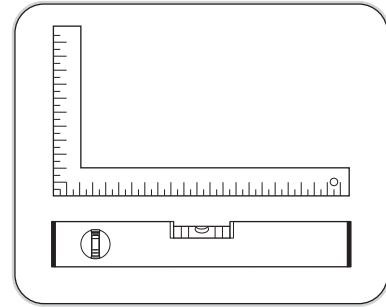

Work on flat level surface.

LOCATION

1. A safe fall zone around your Funky Monkey Bars® is essential. A minimum distance of 1.5m to 2m (5 ft to 6.5ft) is recommended around the elevated hanging points of your Funky Monkey Bars®.
2. Place your Funky Monkey Bars® on level ground, away from any structure or obstruction such as a fence, garage, house, overhanging branches, laundry lines or electrical wires and remove any obstructions beneath your Funky Monkey Bars®.
3. Ensure your Funky Monkey Bars® are positioned away from retaining walls, pool fences, structures and other play equipment. Maintain a clear space around the whole perimeter of your Funky Monkey Bars®.
4. Place your Funky Monkey Bars® on the most level surface available.

MAINTENANCE

1. At the beginning of each heavy play session we recommend the following maintenance processes be performed on your Funky Monkey Bars®:
 - Tighten all bolts, grub screws and applicable hardware (as per page 5)
 - Lubricate all metallic moving parts as per instructions (flying fox, swing hooks etc)
 - Check all protective coverings on bolts, pipes, edges and corners. Replace if they are loose, cracked or missing.
 - Check all moving parts including swing seats, shackles, snap hooks, chains and trolleys for wear, rust, or other deterioration. Replace as needed.
2. Twice a month during play season we would recommend the following maintenance processes be performed on your Funky Monkey Bars®:
 - Tighten all connections and hardware
 - Check all protective coverings on bolts, pipes, edges and corners. Replace if they are loose, cracked or missing.
3. Once a month during play season we would recommend the following maintenance processes be performed on your Funky Monkey Bars®:
 - Lubricate all metallic moving parts as per instructions (flying fox, swing hooks etc). If swings start to squeak then lubricate swing hooks.
 - Check all moving parts including swing seats, ropes, chains and trolleys for wear, rust, or other deterioration. Replace as needed.
 - Owners shall be responsible for maintaining the legibility of any warning labels.

For additional information concerning your Funky Monkey Bars®, please contact our customer service team or check our website for any important updates. Phone - 1300 912 198 or www.funkymonkeybars.com



QUALITY & INDEPENDENT TESTING

At Funky Monkey Bars® we take the quality of our designs and safety very seriously. All Funky Monkey Bars® frames go through a stringent, independent structural testing process prior to being made available for release to our customers.

Our frames are designed within the parameters of the Australian Standard for Playground Equipment AS4685.1:2014.

The structural integrity of our frames has been tested for performance through a combination of engineering calculations and physical testing. The tests have been performed by independent, certified structural engineers in accordance with Australian Standard for Playground Equipment AS4685.1:2014 and European Standards EN1176-1:2008.

The independent testing conducted on The New Ninja certified the frame to a load rating of 1200kgs or 21 users.

LOAD TESTING CERTIFICATION				
DATE OF TEST	MODEL	NUMBER OF USERS	USER LOAD (KG)	LOAD RATING (KG)
Jul 2020	New Ninja	21	60	1200
I hereby confirm all testing was undertaken in accordance with Physical Testing of Structural Integrity requirements of AS 4685.1: 2014 App C / EN 1176-1:2008 ^o except where noted below;				
COMMENTS: N/A				
APPROVED BY: Funky Monkey Bars®			WITNESSED BY: Independent Engineer	
				
DATE : Jul 2020			DATE : Jul 2020	

DIMENSIONS

FUNKY MONKEY BARS® THE NEW NINJA OVERALL DIMENSIONS

A minimum of 2.0 Metres clear fall zone is recommended around the elevated hanging points of your Funky Monkey Bars®.

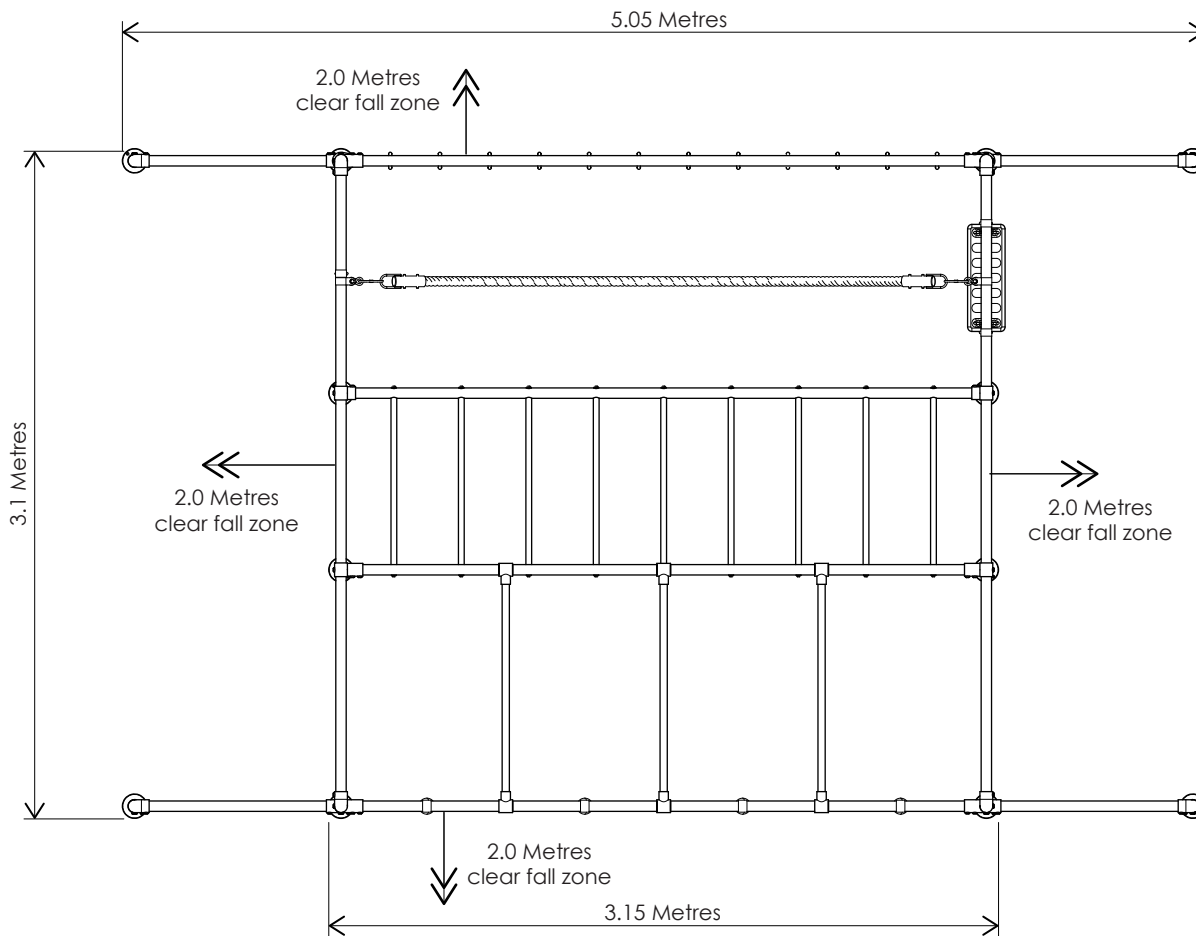

PLAN VIEW
(not to scale)

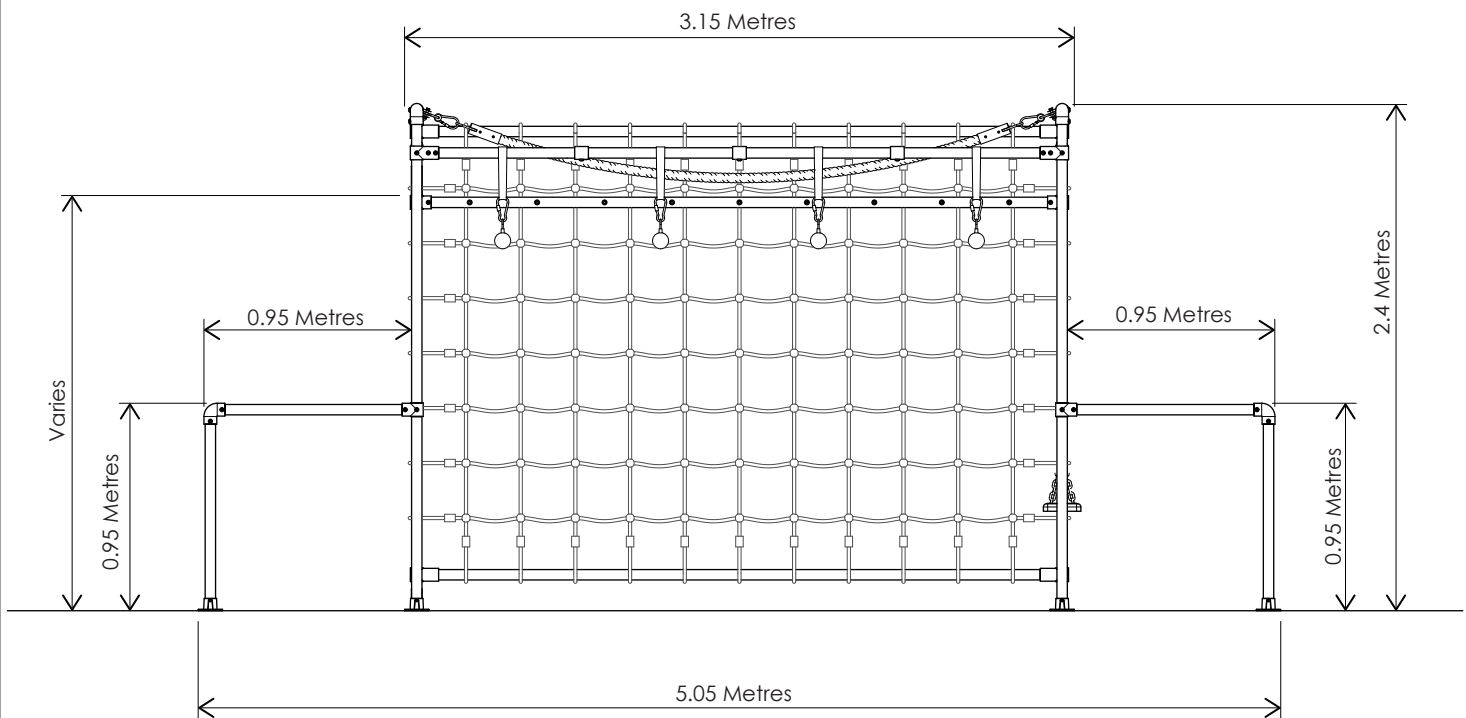

SIDE VIEW
(not to scale)

ASSEMBLY TIPS

CORRECT INSERTION INTO FITTINGS - (INDICATIVE DIAGRAM SHOWN)

All tubes must be fully inserted until contact is made with adjoining tube.

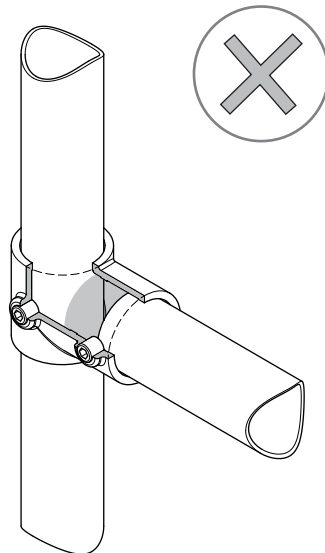

Gap.

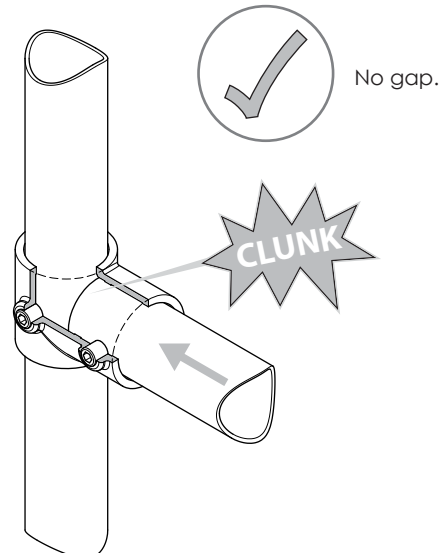

No gap.

CORRECT TIGHTENING METHOD OF GRUB SCREWS - (INDICATIVE DIAGRAM SHOWN)

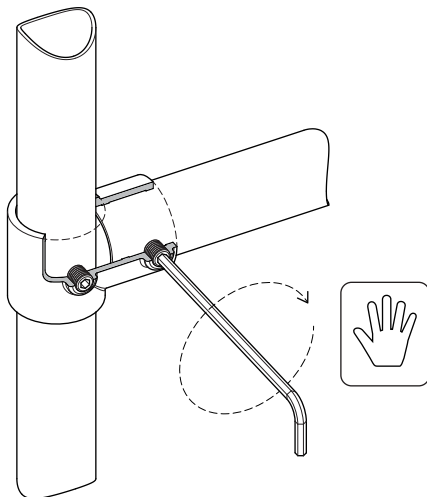

1. With long end of allen key, hand tighten grub screw as much as possible.

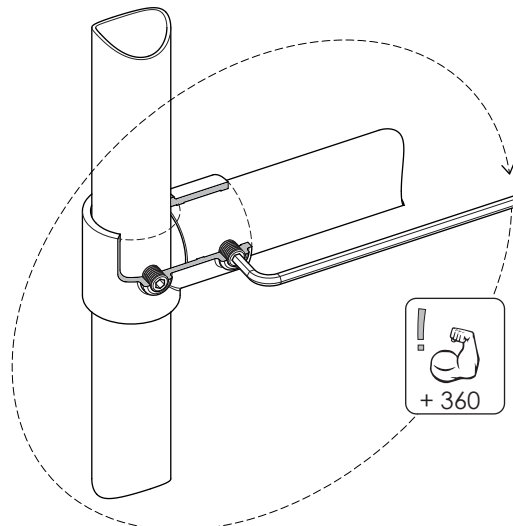

2. Using other end of the allen key do one full 360 degree turn as a minimum, use muscles!



CORRECT TIGHTENING METHOD OF RUNG BOLTS - (INDICATIVE DIAGRAM SHOWN)

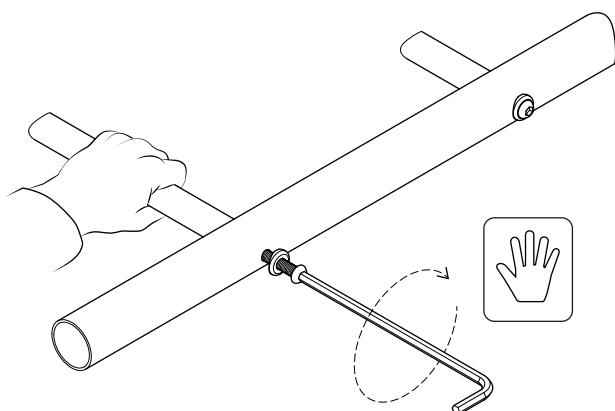

1. With long end of allen key, hand tighten bolt hard up against washer and outside of tube. Hold rung to avoid rotation.

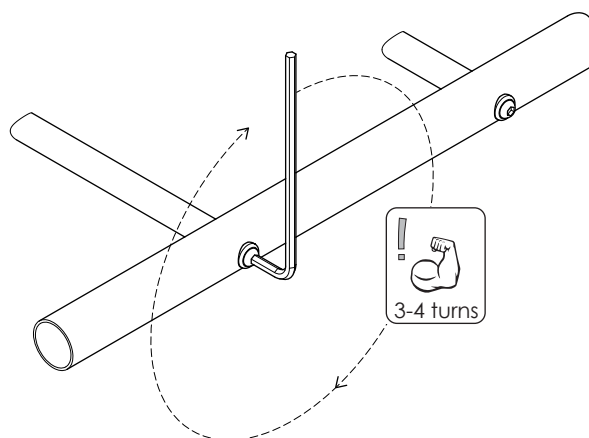

2. Using short end of the allen key fully tighten, approximately 3-4 full turns .



ASSEMBLY TIPS (CONTINUED)

IT IS CRITICAL YOUR MAIN FRAME IS 100% SQUARE AND LEVEL (INDICATIVE DIAGRAM SHOWN)

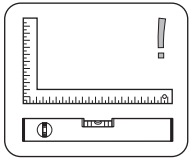

Check assembly is 100% level, square & straight.

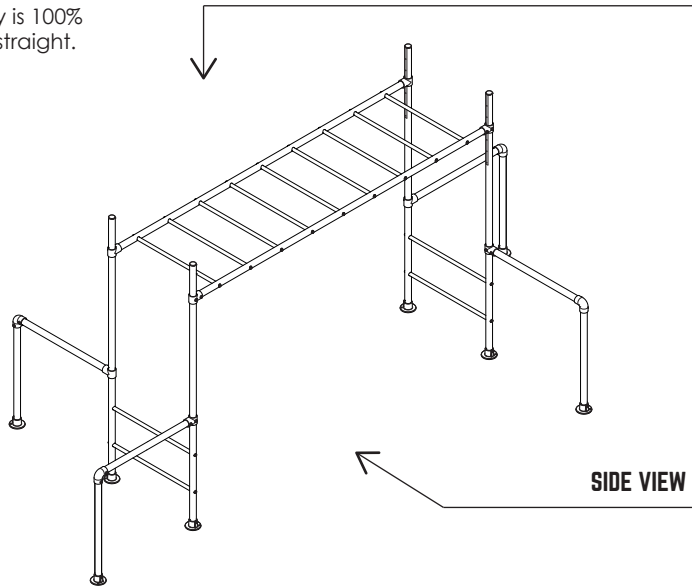

PLAN VIEW

SIDE VIEW

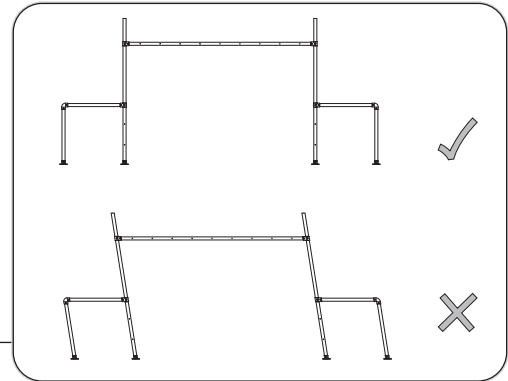
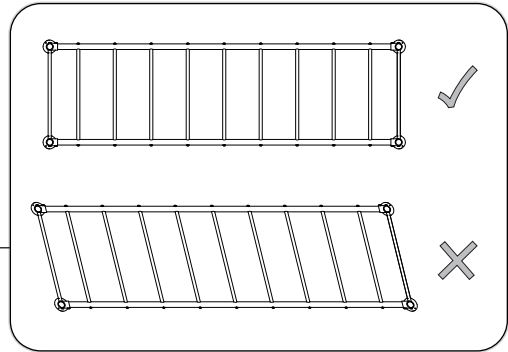

If your frame is not straight or level remove pegs, loosen grub screws, re-adjust re-tighten and re-peg the frame.

INSTALLATION ON A SLOPE

If your frame is being installed on a slope ensure the monkey ladder bar is level. Either install at different heights on the legs or dig down at one end until level.

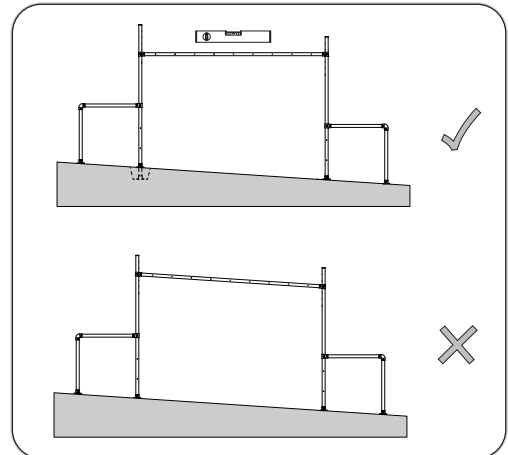

FIXING TYPICAL ORIENTATION - (INDICATIVE DRAWING SHOWN)

Unless otherwise stated all grub screws and fittings should face downwards and outwards. This will reduce weathering damage, help with assembly and ease of maintenance.

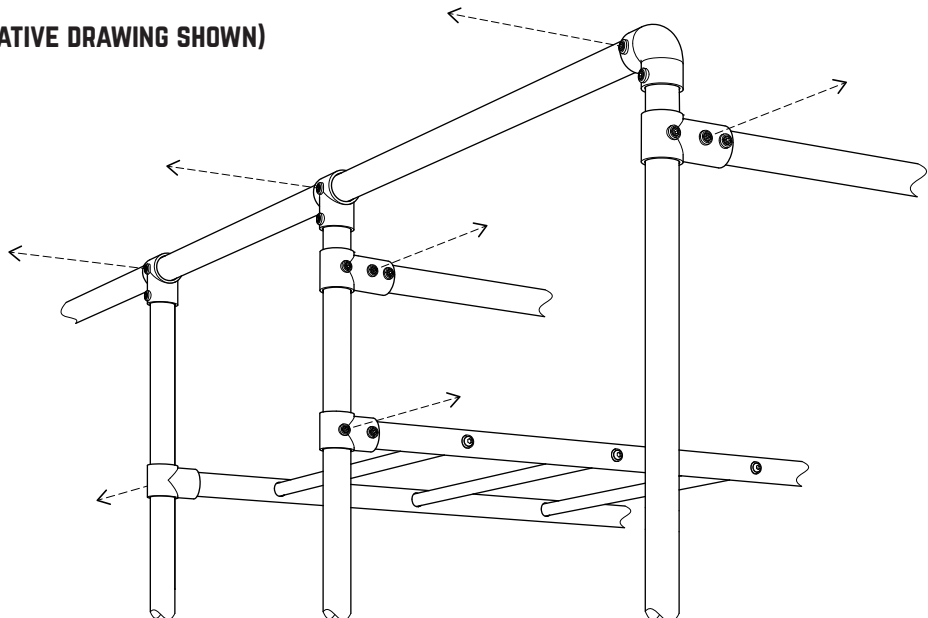

INVENTORY

SUPPLIED BOXES.

NOTE: The New Ninja frame comprises of a total of 18 boxes: (some found inside other boxes)

QUANTITY.	CODE.	DESCRIPTION.
1	A1	2 x Ladder Tubes
2	B1	2 x Adjustable Leg Tubes
1	C1	8 x Colour Twirly Whirly Tubes
1	D-13	13 x Colour Rung Tubes
3	F2	6 (Total) x Silver 2950mm Accessories Tubes
2	F5	4 (Total) x Silver 2300 Swing Leg Tubes
1	I6	3 x Silver 1040mm Lache Bar Tubes 33Ø
1	N	Accessories Box
1	O2	Cargo Net
1	Q5	Fittings and Hardware
1	Q20	Fittings and Hardware
1	Q31	Fittings and Hardware (Inside box N)
2	Q32	Fittings and Hardware (Inside box N)
Total 18		

TOOLS REQUIRED FOR INSTALLATION

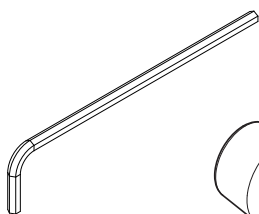

1x
8mm Allen key
(Included)

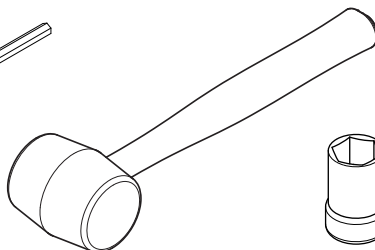

1x
Soft Hammer
(Not included)

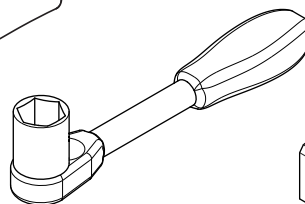

1x
17mm Ratchet
(Not included)

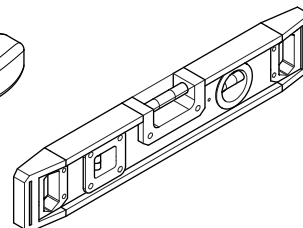

1x
Spirit Level
(Not included)

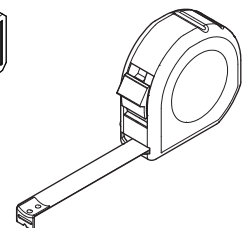



1x
Tape Measure
(Not included)

INVENTORY (CONTINUED)

TUBES

13x
Rung Tube 

8x
Twirly Tube 

3x
Lache Tube 

4x
Swing Leg Tube 

4x
Adj. Leg Tube 

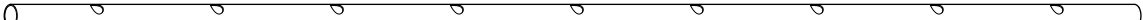
2x
Ladder Tube 

6x
Double Swing/
Accessories Tube 

FITTINGS

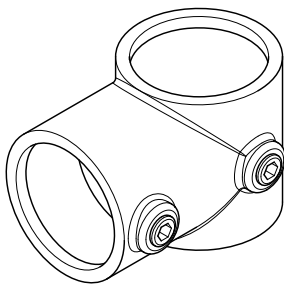

12x
Short Tee
D-101

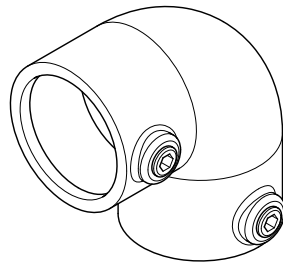

8x
Elbow
D-125

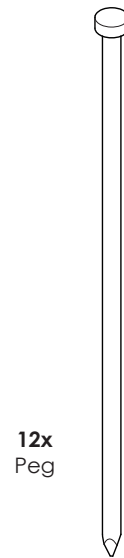

12x
Peg

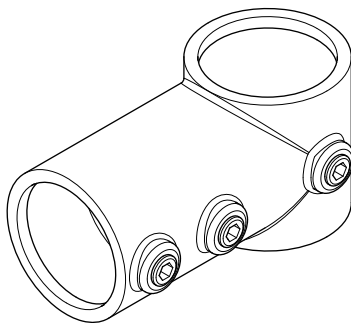

8x
Long Short Tee
D-101L

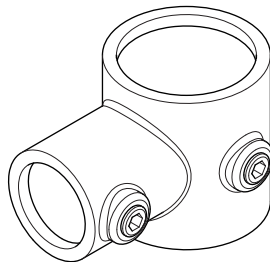

6x
Reducing Tee
D-101 D48-B34

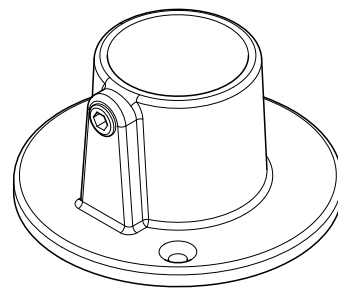

12x
Base Plate
D-131

INVENTORY (CONTINUED)

HARDWARE

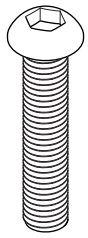

27x
M10 Bolt

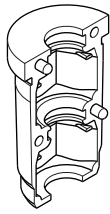

54x
Rung Insert

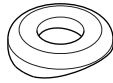

27x
Washer



54x
M10 Hex Nut

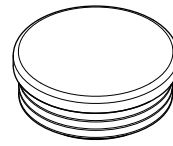

4x
Plastic End Cap



1x
Manufacture Sticker



2x
Logo Sticker



1x
Warning Label Sticker



2x
Australia Made Sticker

4x
Height Sticker

COMPONENTS (ACCESSORIES IF APPLICABLE)

5x
Swing Hooks



4x
Ninja Grips
(Round)



1x
Rubber Swing

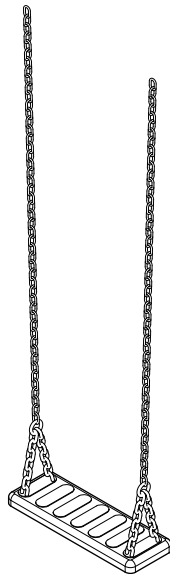

1x
2.3m
Jungle Rope



1x
3m Cargo Net
(11x7 rungs)

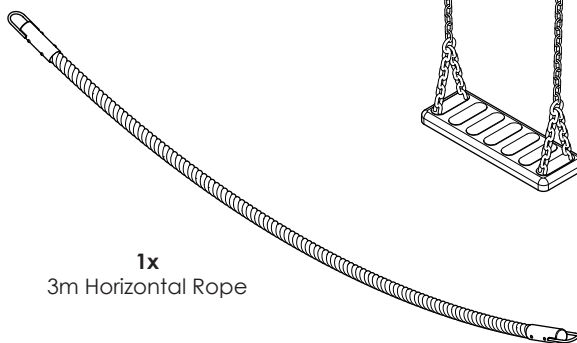
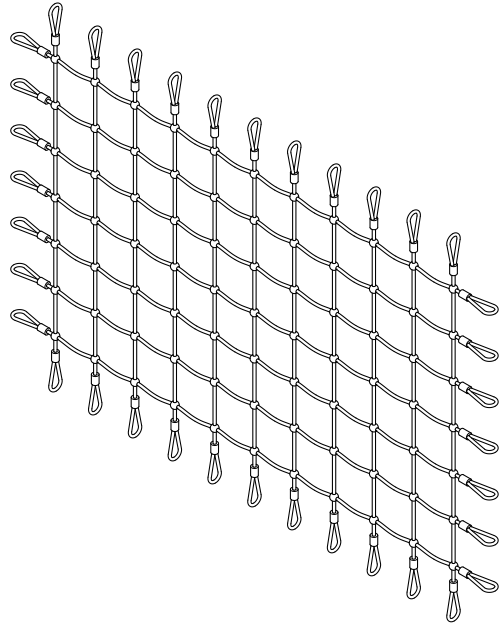

1x
3m Horizontal Rope

NOTE: Refer to separate accessory installation instructions if supplied.

One of the best things about Funky Monkey Bars® is the ability to add new equipment and accessories as your child and family grows. You can swap or add accessories to your existing frame, or add extra frames that will give you more versatility to attach equipment. Check out what we've got in store now at...

WWW.FUNKYMONKEYBARS.COM

ASSEMBLY INSTRUCTIONS - LADDER BAR ASSEMBLY

1 RUNG ASSEMBLY (X13)

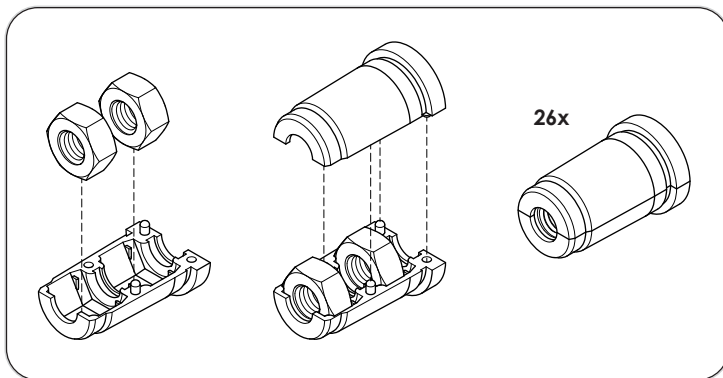

1. Assemble plastic rung inserts as shown above.

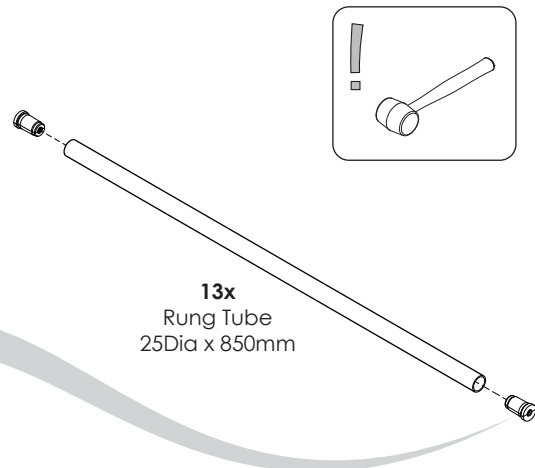

2. Push inserts into both ends of all rungs.

2 MONKEY BAR LADDER ASSEMBLY

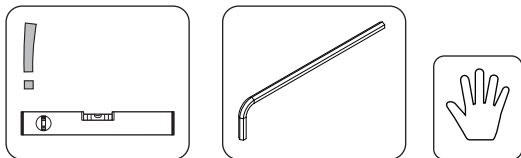

On flat surface insert rungs from step 1 into a ladder tube. Hand tighten grub screws.

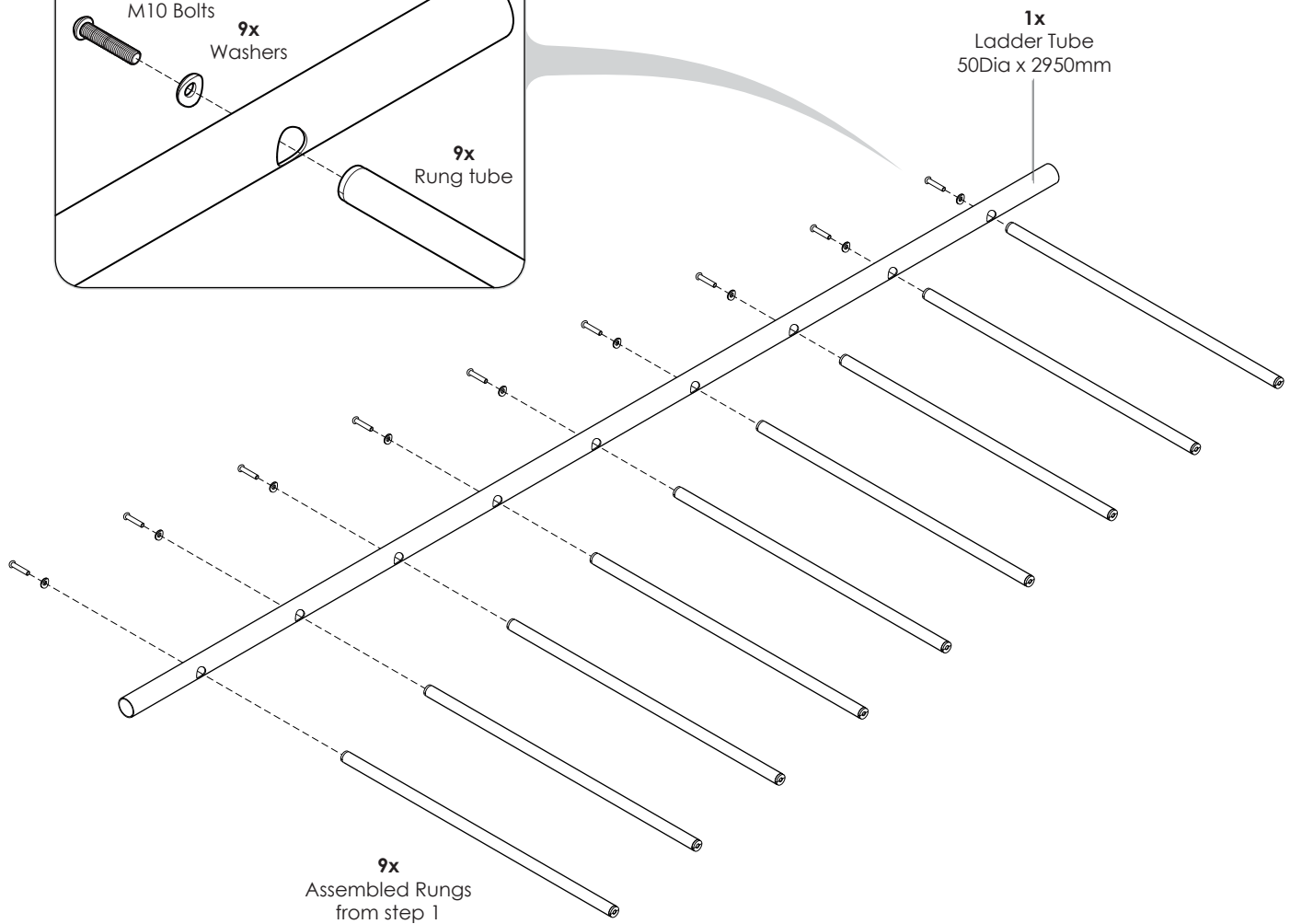
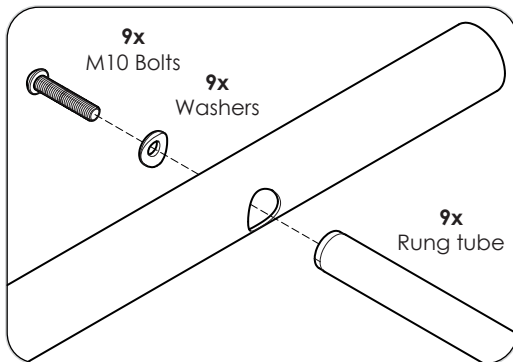

3 ATTACH SECOND LADDER TUBE

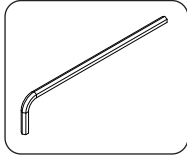

Hand tighten all bolts

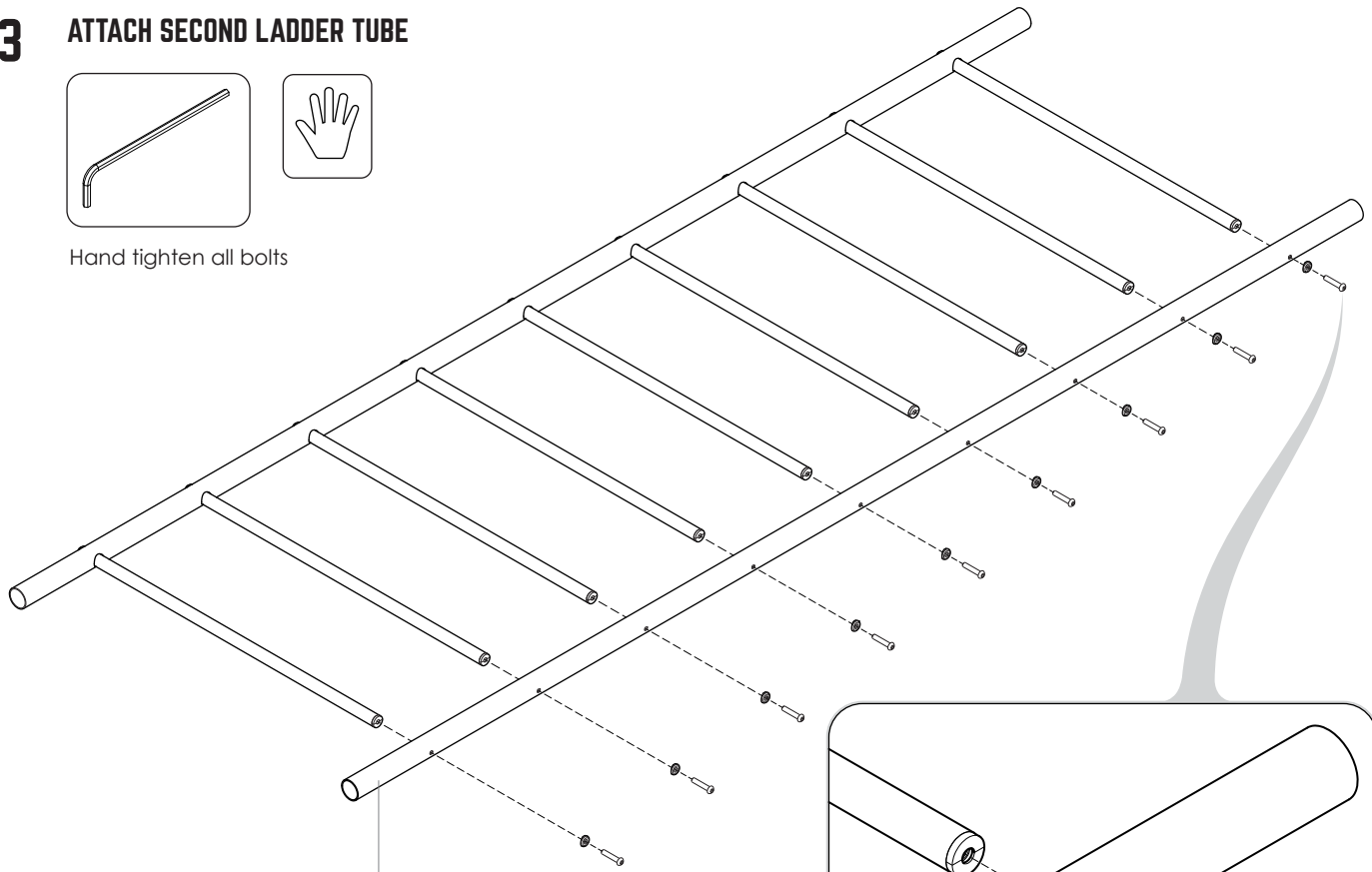

1x
Ladder Tube
50Dia x 2950mm

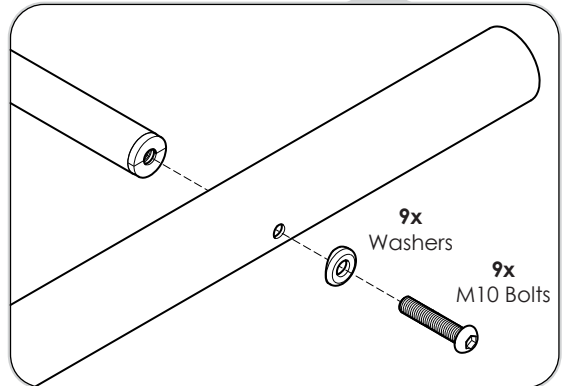

4 FIRMLY TIGHTEN ALL RUNG BOLTS.

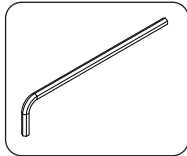

See page 5 for correct tightening method.

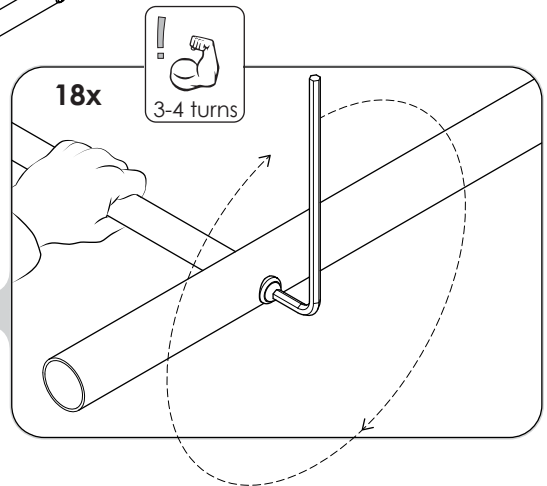
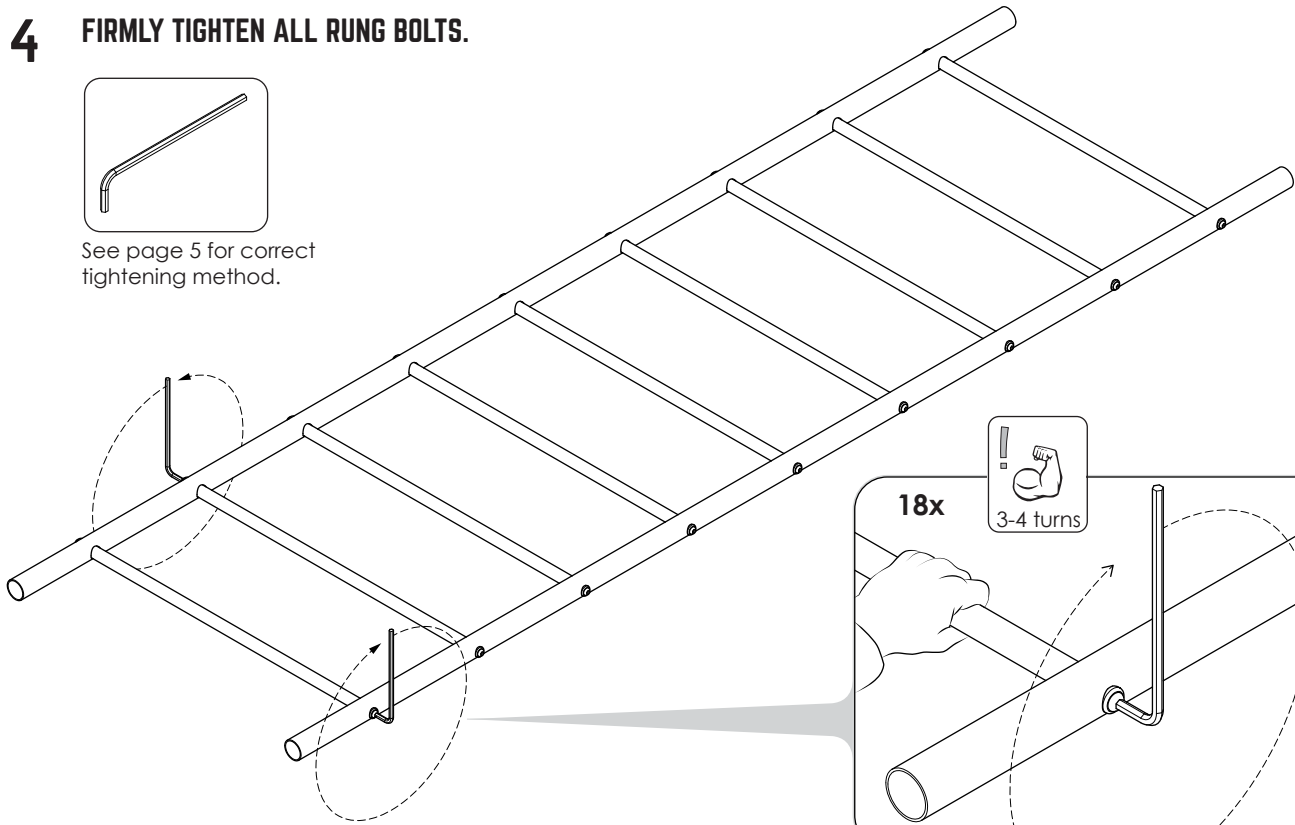

ASSEMBLY INSTRUCTIONS - LEG ASSEMBLY

5 LEG ASSEMBLY X2

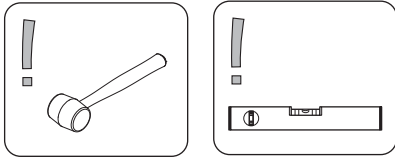

On flat level ground insert plastic end caps into leg tubes.

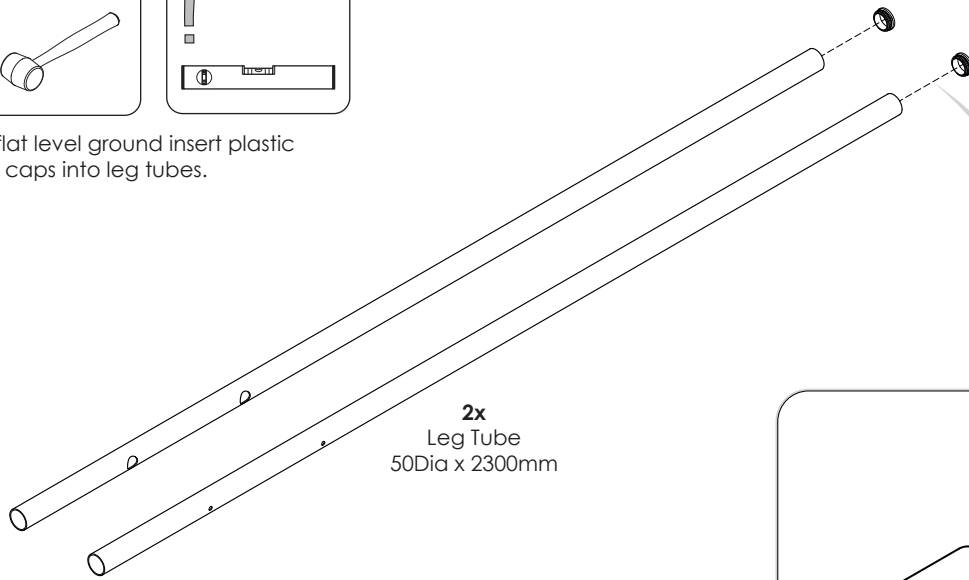

2x
Leg Tube
50Dia x 2300mm

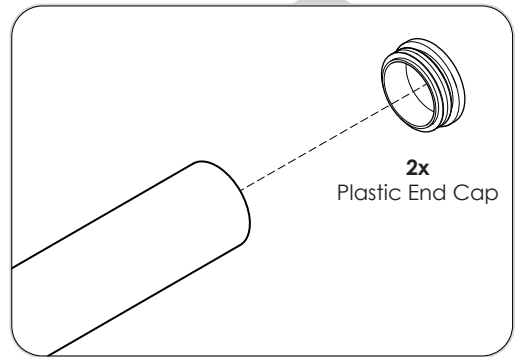

2x
Plastic End Cap

6 INSERT RUNGS INTO LEG

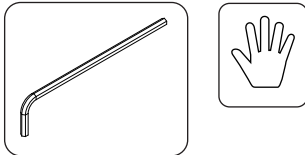

Hand tighten all bolts.

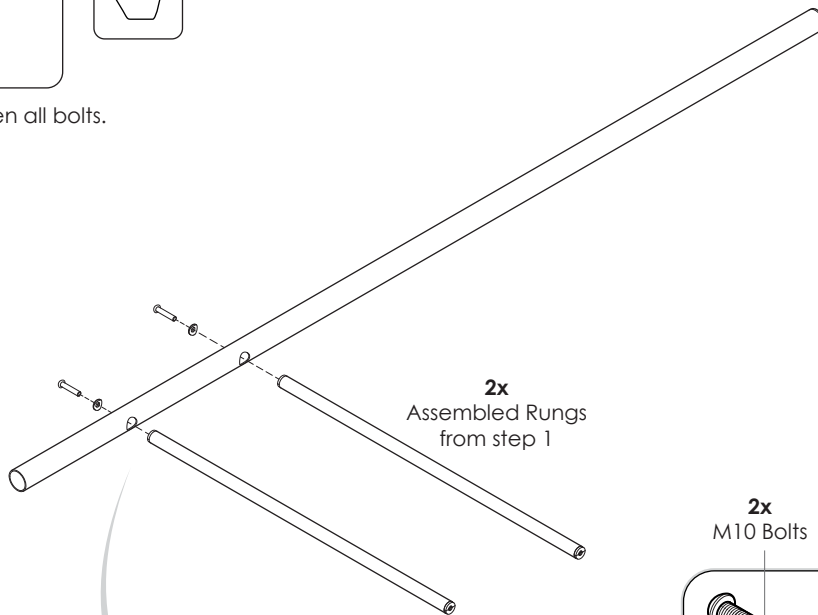

2x
Assembled Rungs
from step 1

2x M10 Bolts
2x Washers

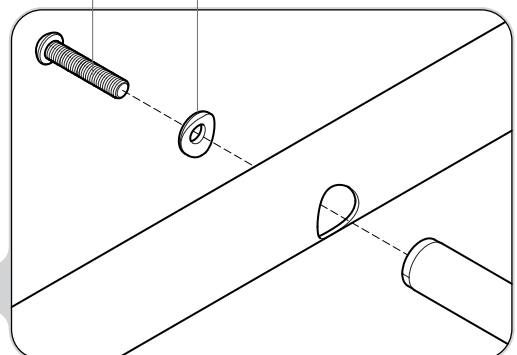

7 ATTACH SECOND LEG

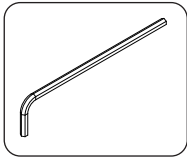

Hand tighten all bolts.

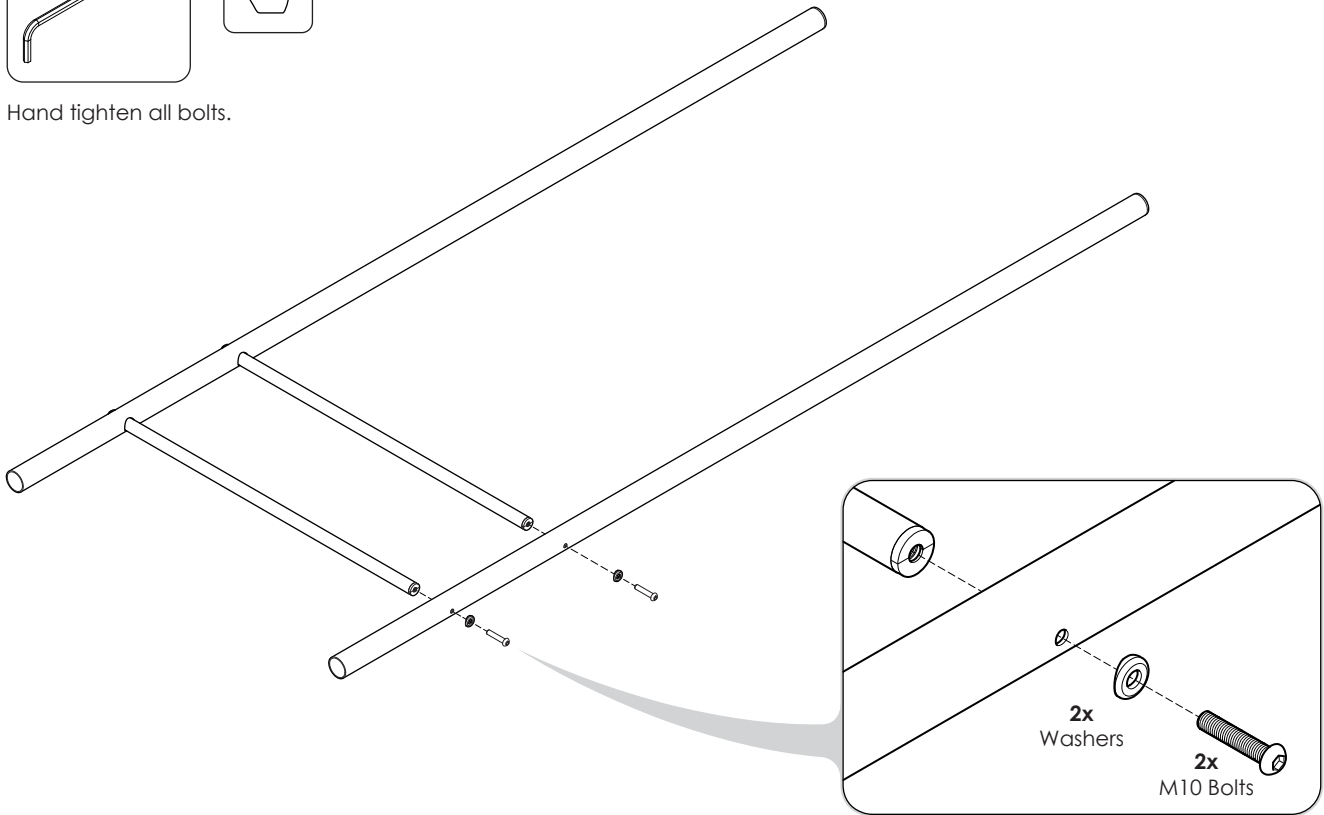

8 ATTACH BASE PLATES

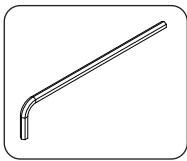

Tighten all grub screws.

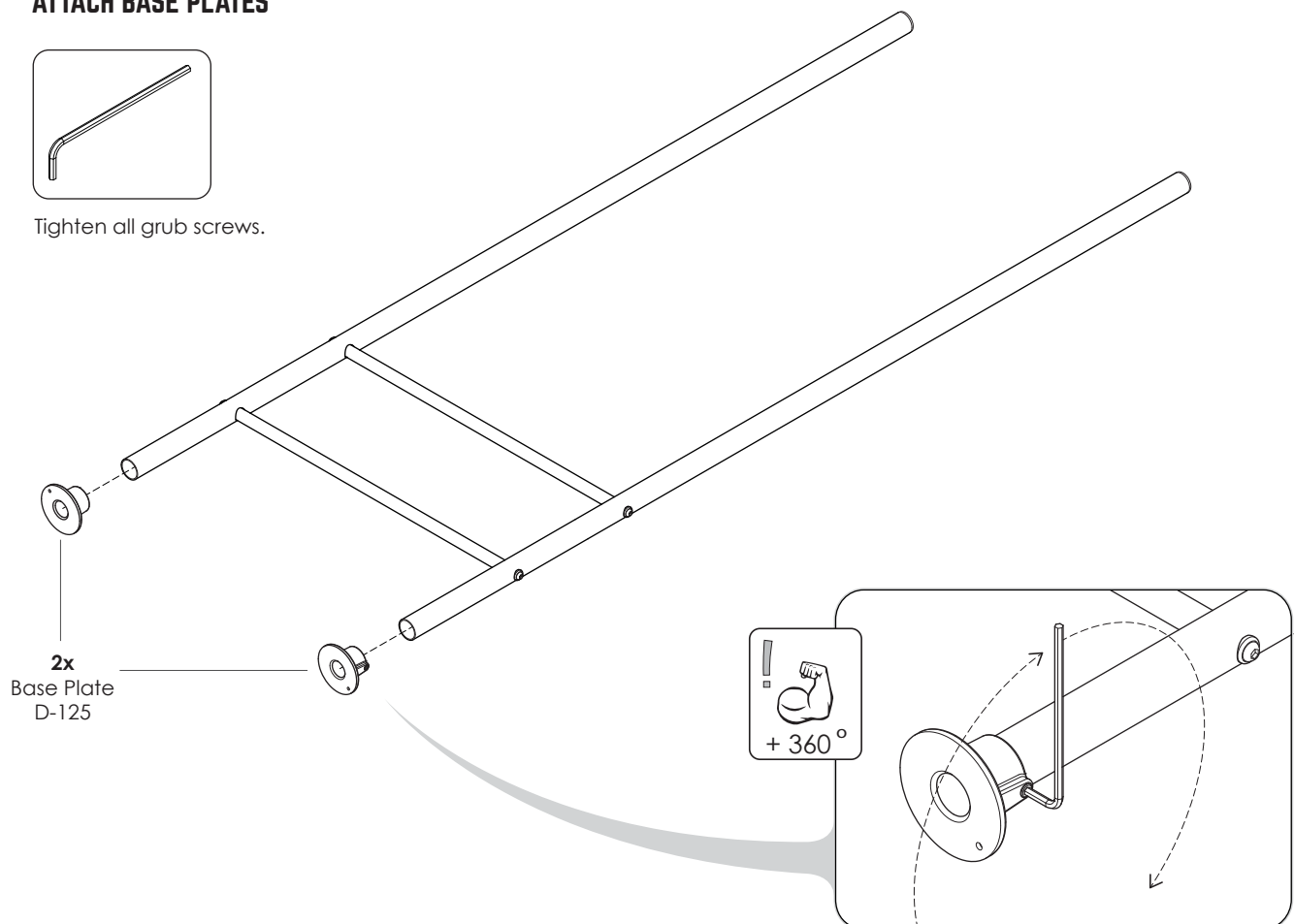

9 APPLY HEIGHT STICKERS.

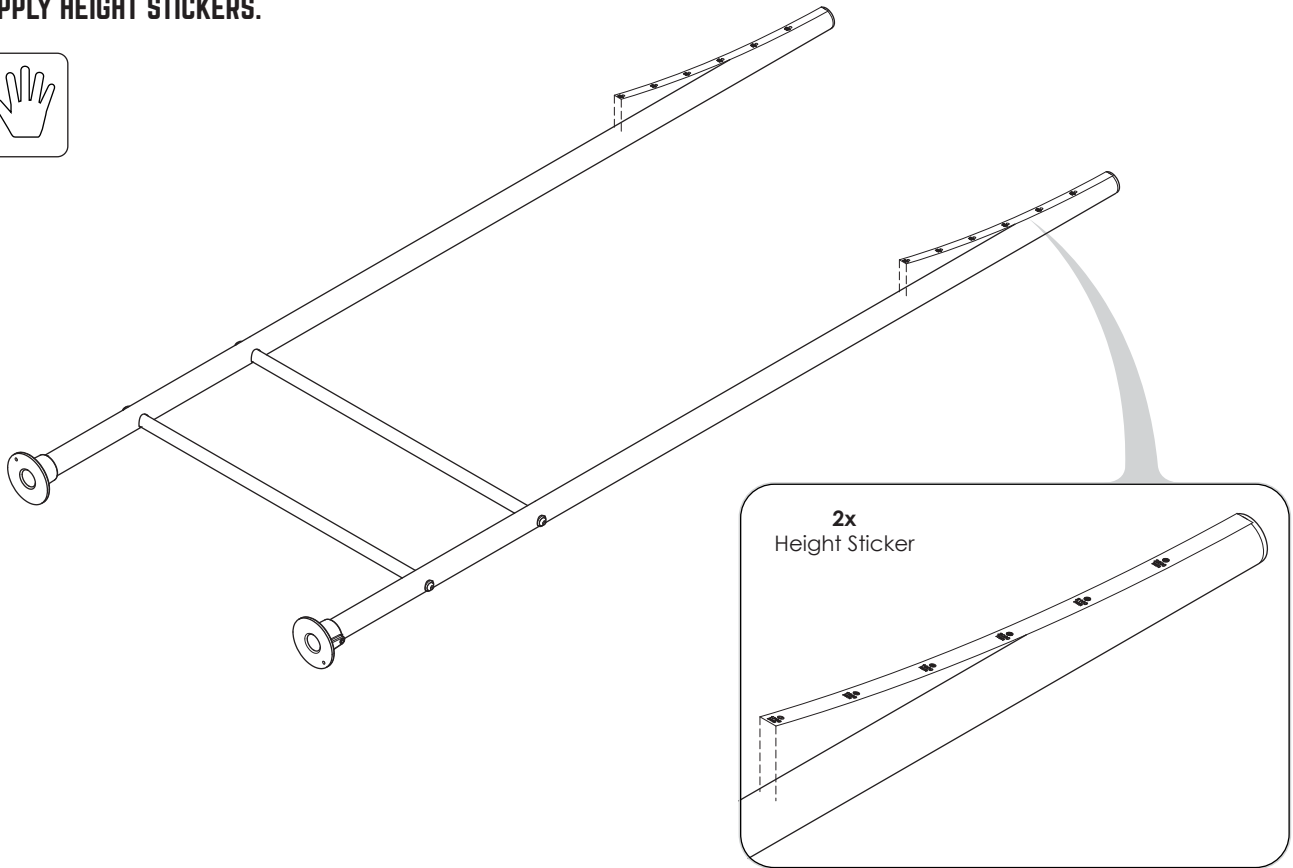

10 SET LADDER BAR HEIGHT.

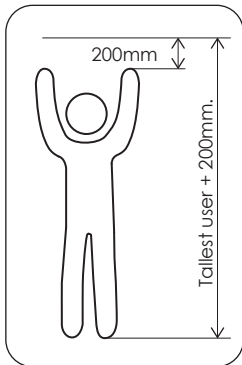

Good starting height is 100-200mm above reach.

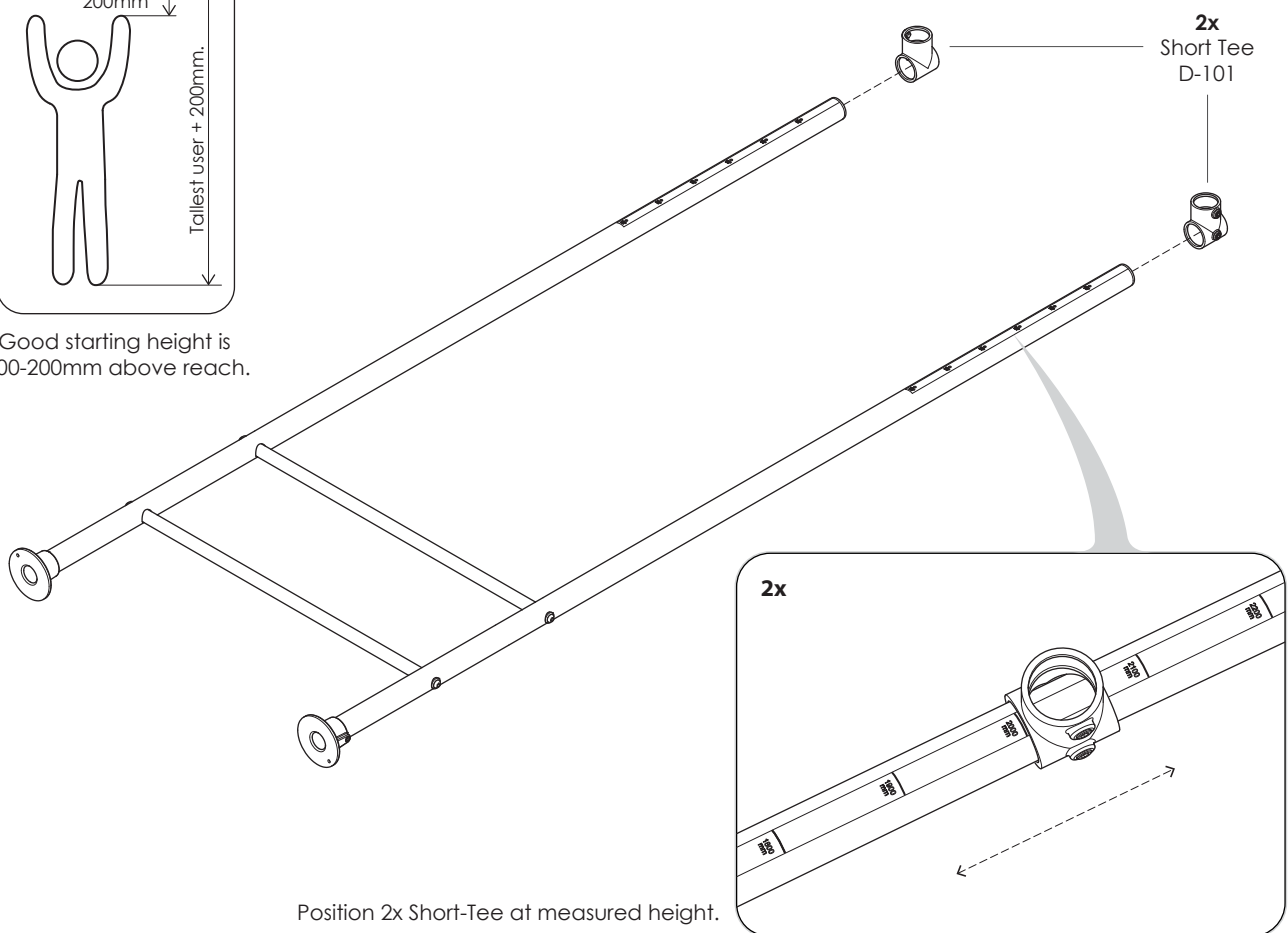

Position 2x Short-Tee at measured height.

11 FIRMLY TIGHTEN ALL RUNG BOLTS & GRUB SCREWS.

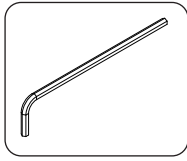

6x

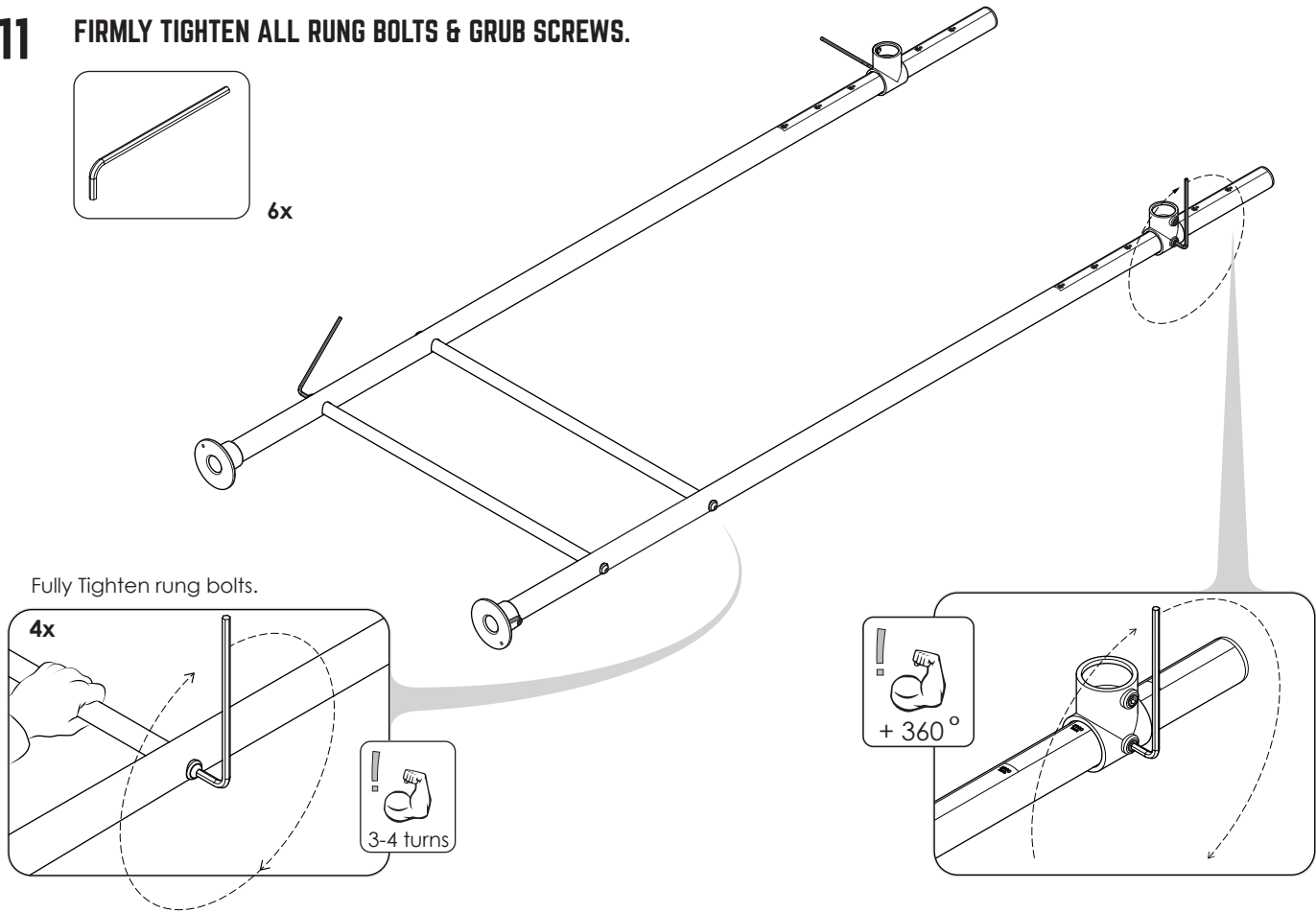

Fully Tighten rung bolts.

4x

3-4 turns

+ 360°

12 REPEAT STEPS 5 - 11 FOR 1X MORE SET OF LEGS. (ENSURE SHORT TEES ARE SET AT THE SAME HEIGHT)

13 LEG ASSEMBLY x 2.

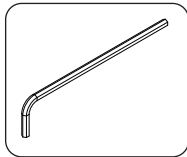

1. Stand legs up with top tees facing each other.
2. Check all grub screws are fully tightened.

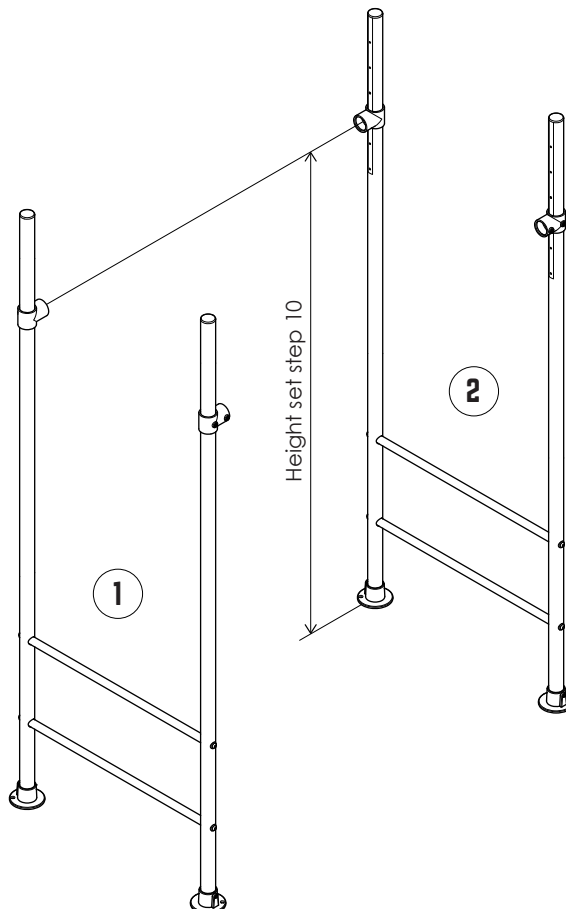

ASSEMBLY INSTRUCTIONS - MAIN MONKEY BAR ASSEMBLY

14 FLIP LEGS 1 & 2 OVER

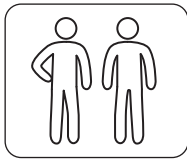

For the following step the legs should be flipped over & attached one at a time.

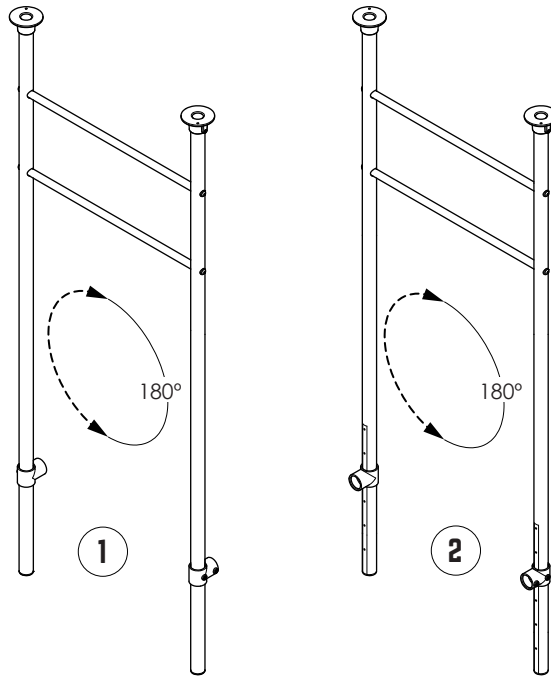

15 ATTACH 2X LEGS TO LADDER

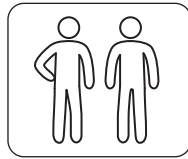
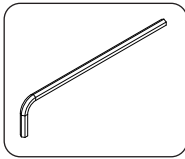

1. Attach first set of legs ① - tighten all grub screws.
2. Attach second set of legs ② - tighten all grub screws.

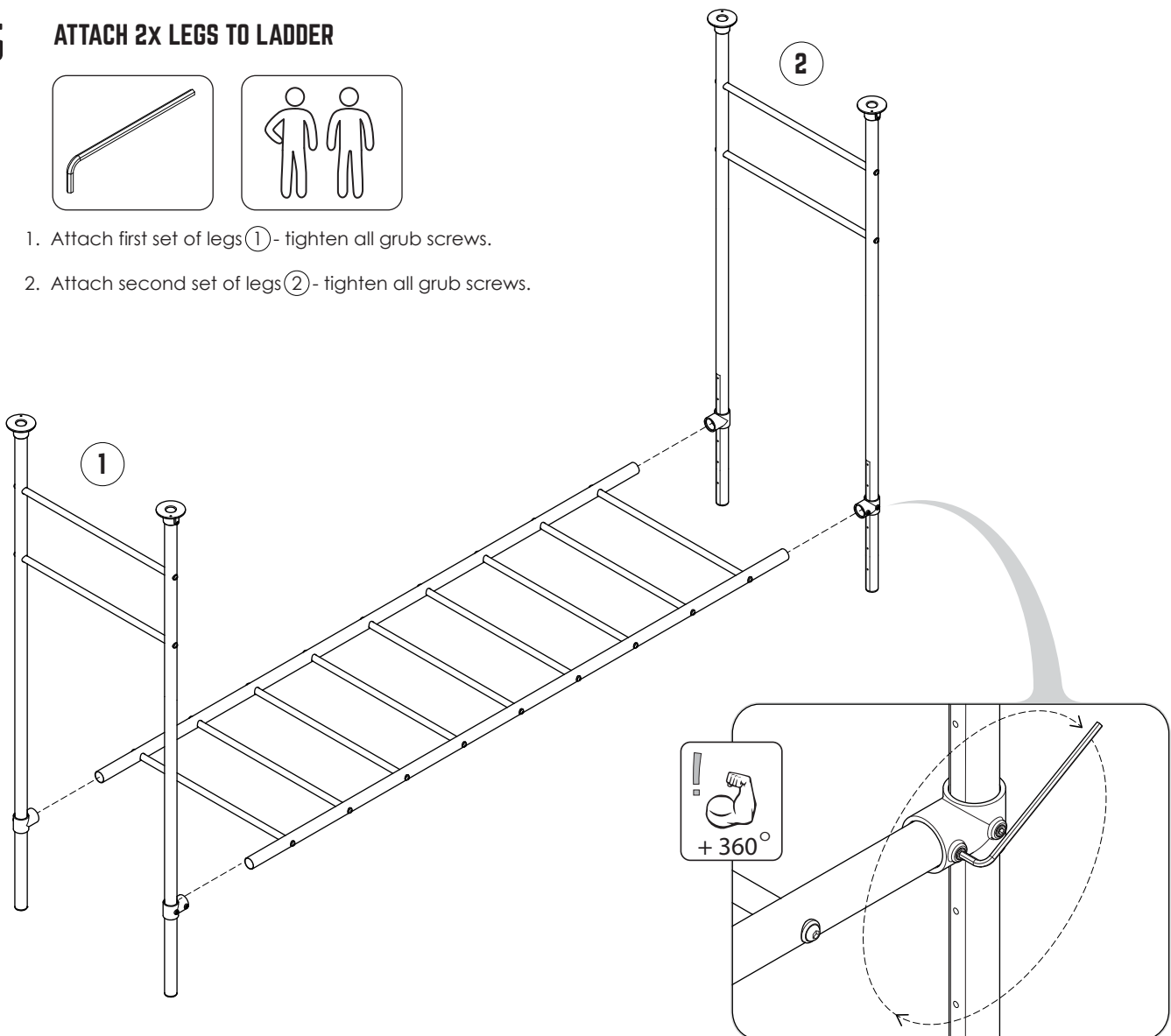

16 FLIP ASSEMBLY OVER

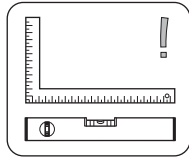
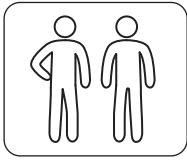

1. With 2 people flip the assembly over on its base plates.
2. Check that it is square and level.

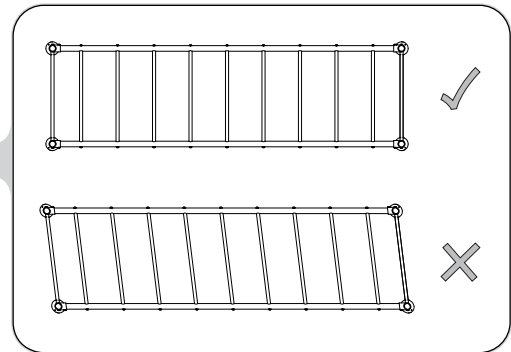
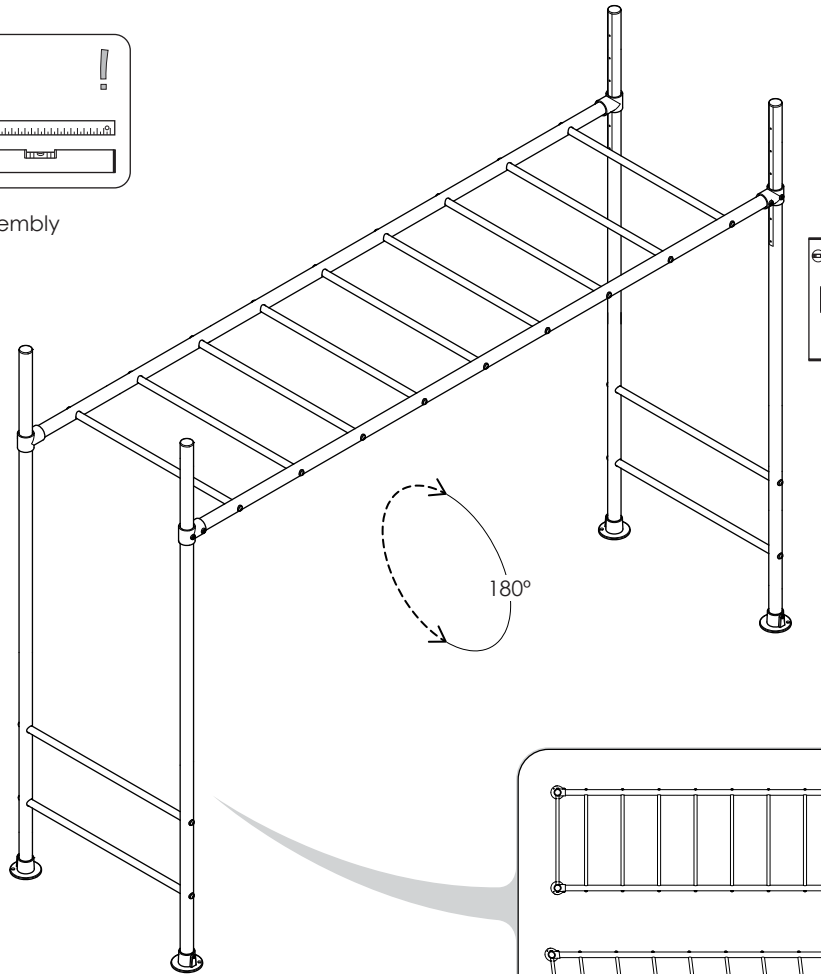

CRITICAL : ENSURE YOUR FRAME IS 100% SQUARE AND LEVEL (AS PER PAGE 6) BEFORE MOVING ONTO THE REST OF THE ASSEMBLY

17 SECURE TO GROUND

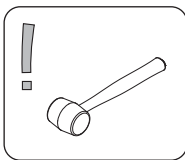

1. Move into selected suitable location with adequate fall zone. (refer to page 4).
2. Hammer in pegs x4.

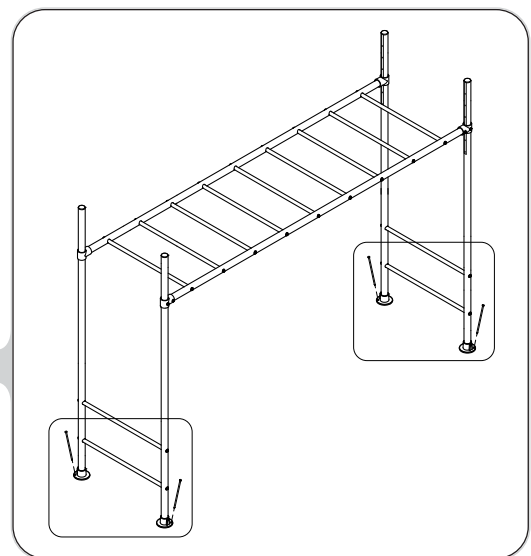
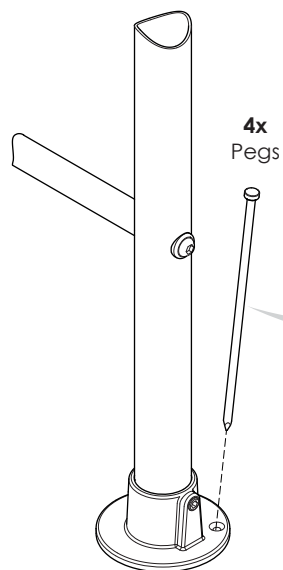

18 ATTACH FITTINGS

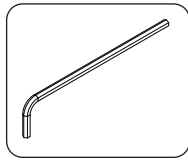

1. On flat level ground slide 3 reducing tees onto the accessories bar, then attach a long short tee to each end.
2. Ensure the long short tees are correctly fitted as per detail.
3. Fully tighten grub screws on long short tees and leave loose on reducing tees.

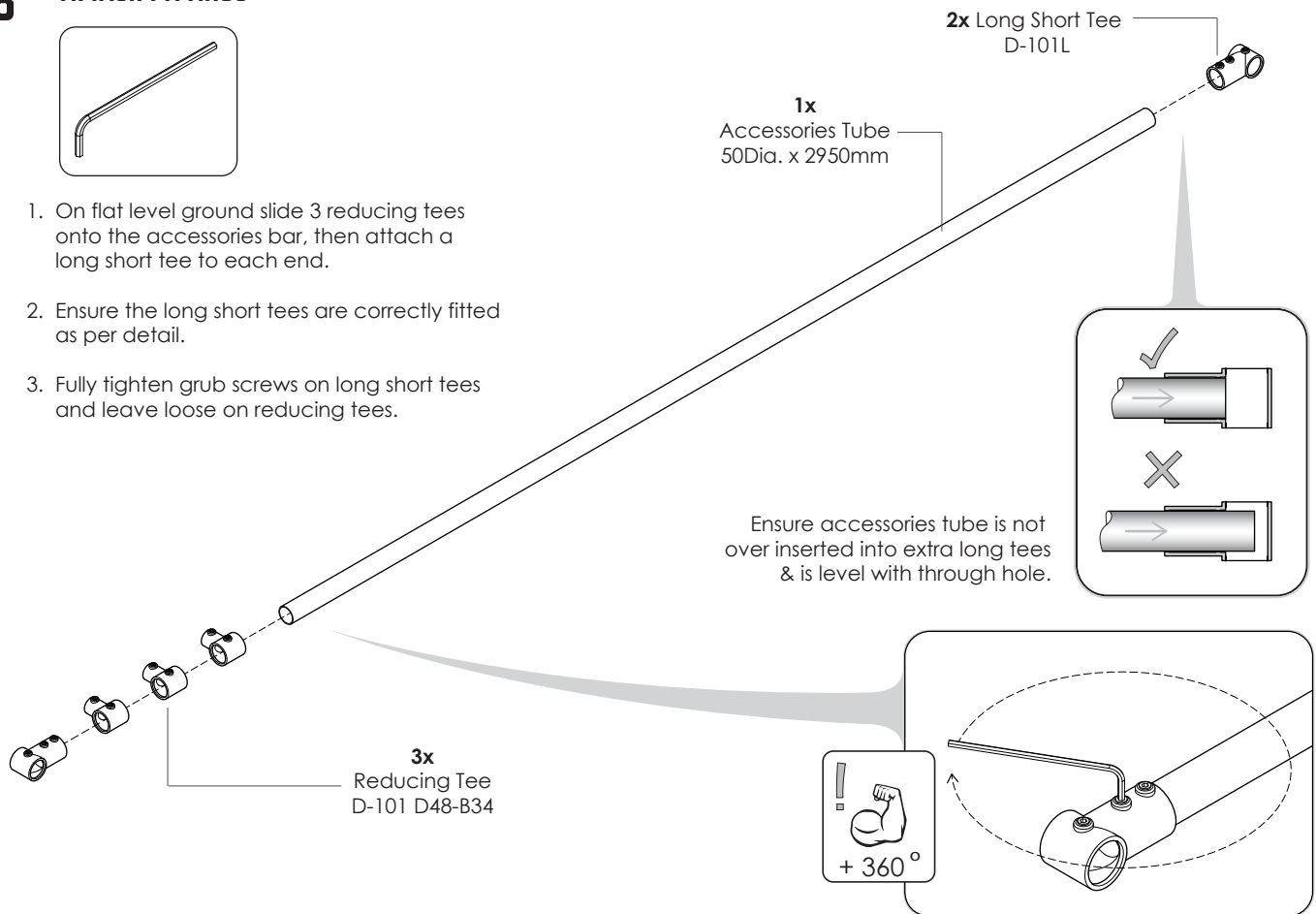

19 ATTACH LACHE TUBES

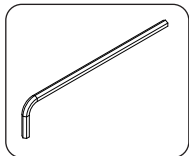

1. Space reducing tees as shown. (User preference)
2. Attach 3x lache bars and fully tighten fixings 'A' but leave fixings 'B' loose for later adjustment.

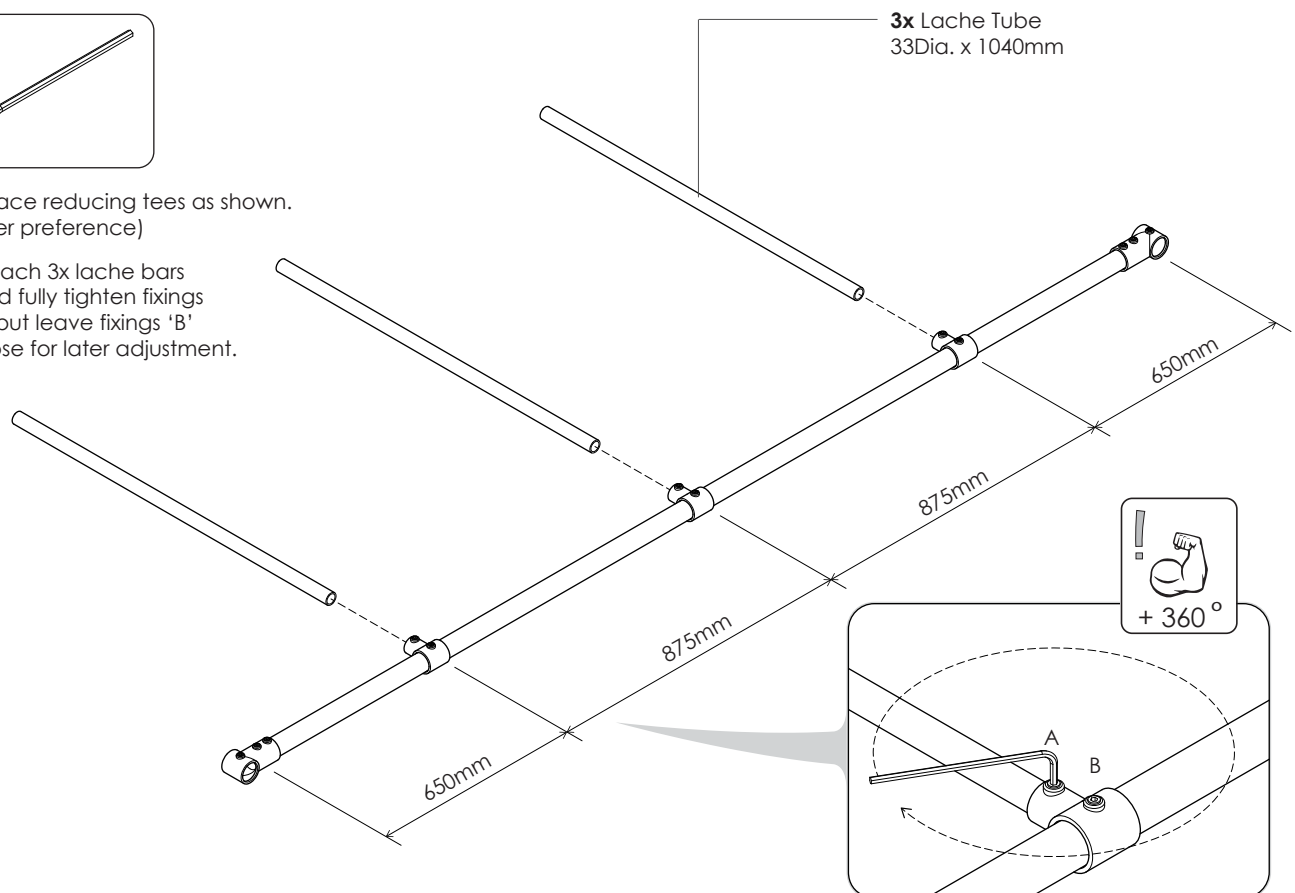

20 ATTACH LACHE BAR ASSEMBLY

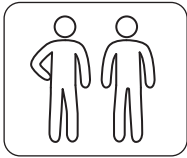

1. With 2 people rotate the assembly and slide onto adjustable legs to a desired height 'X'.
2. Check that it is square and level.
3. Ensure that the grub screws on the reducing tees will be facing downwards when lifted into position.
3. Fully tighten long short tee grub screws. Leave reducing tees loose.

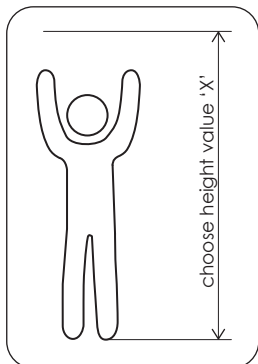
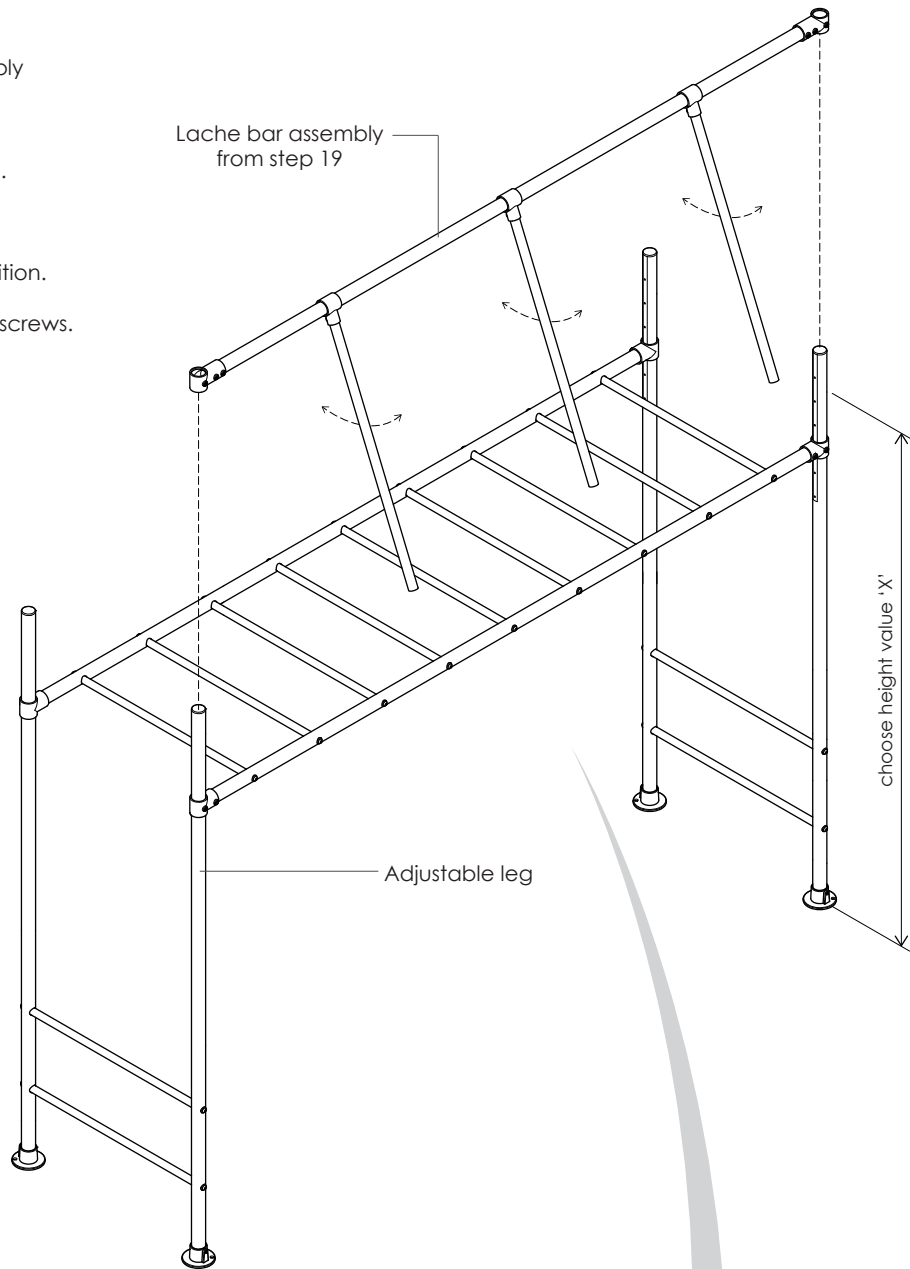

Depending on skills and user height, select a suitable lache bars height.

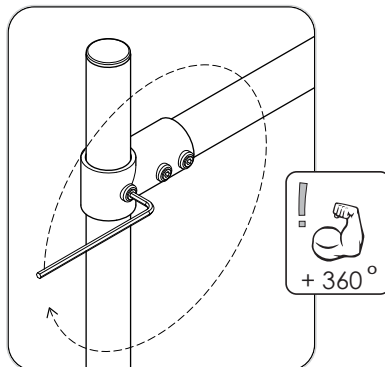

Fully tighten grub screws.

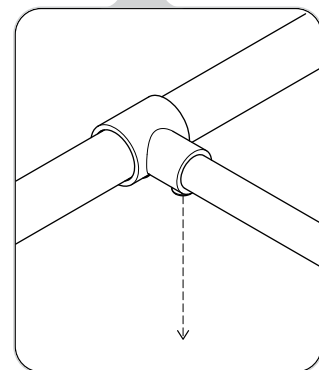

Grub screws facing downwards when in position.

ASSEMBLY INSTRUCTIONS - SWING BAR ASSEMBLY

21 SWING BAR ASSEMBLY X2.

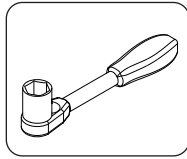
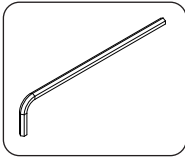

Slide on all fittings. Leave short tees and swing hooks hand tight only for assembly adjustment later, see below for spacing.

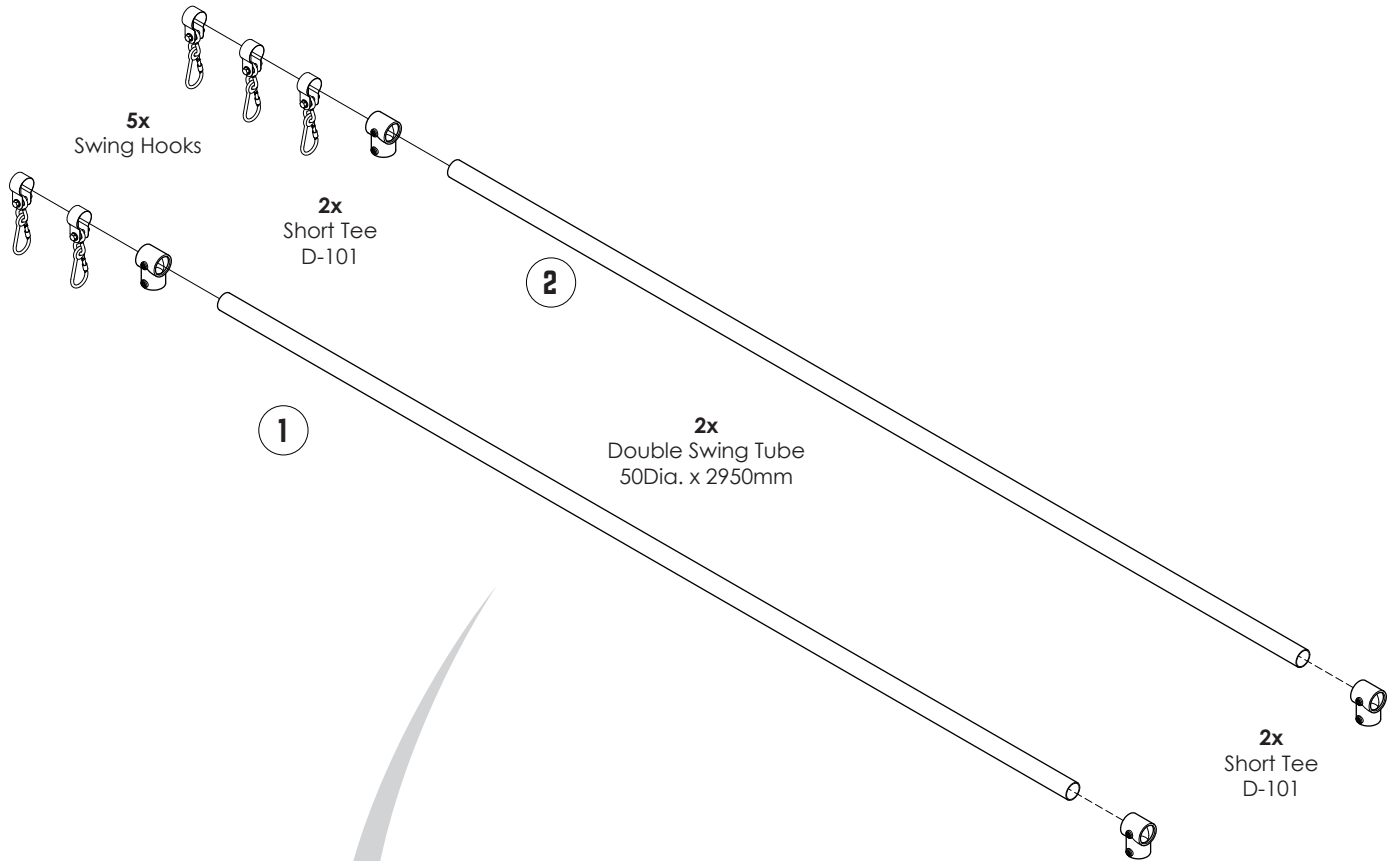

2X SWING BARS ASSEMBLED

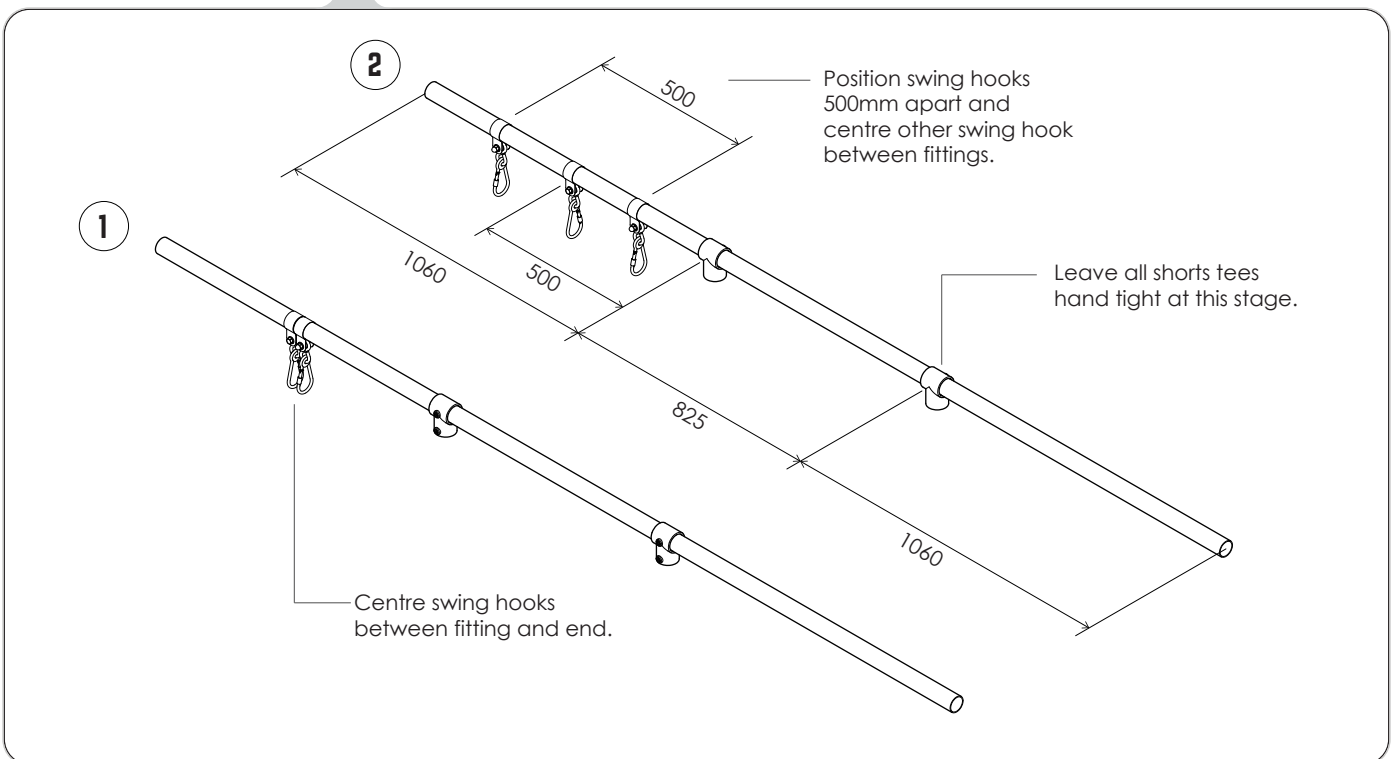

22

ATTACH 2x SWING BAR ASSEMBLY.

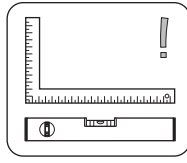
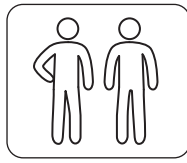
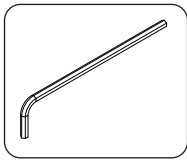

Attach the short tees (on the double swing bars) to the main monkey bar ladder legs. Check the swing bars are level and square. Fully tighten all grub screws.

Double swing bar assemblies from step 21.

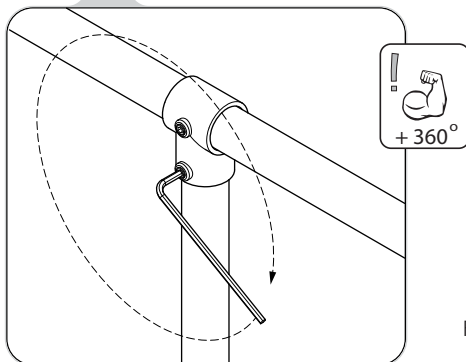
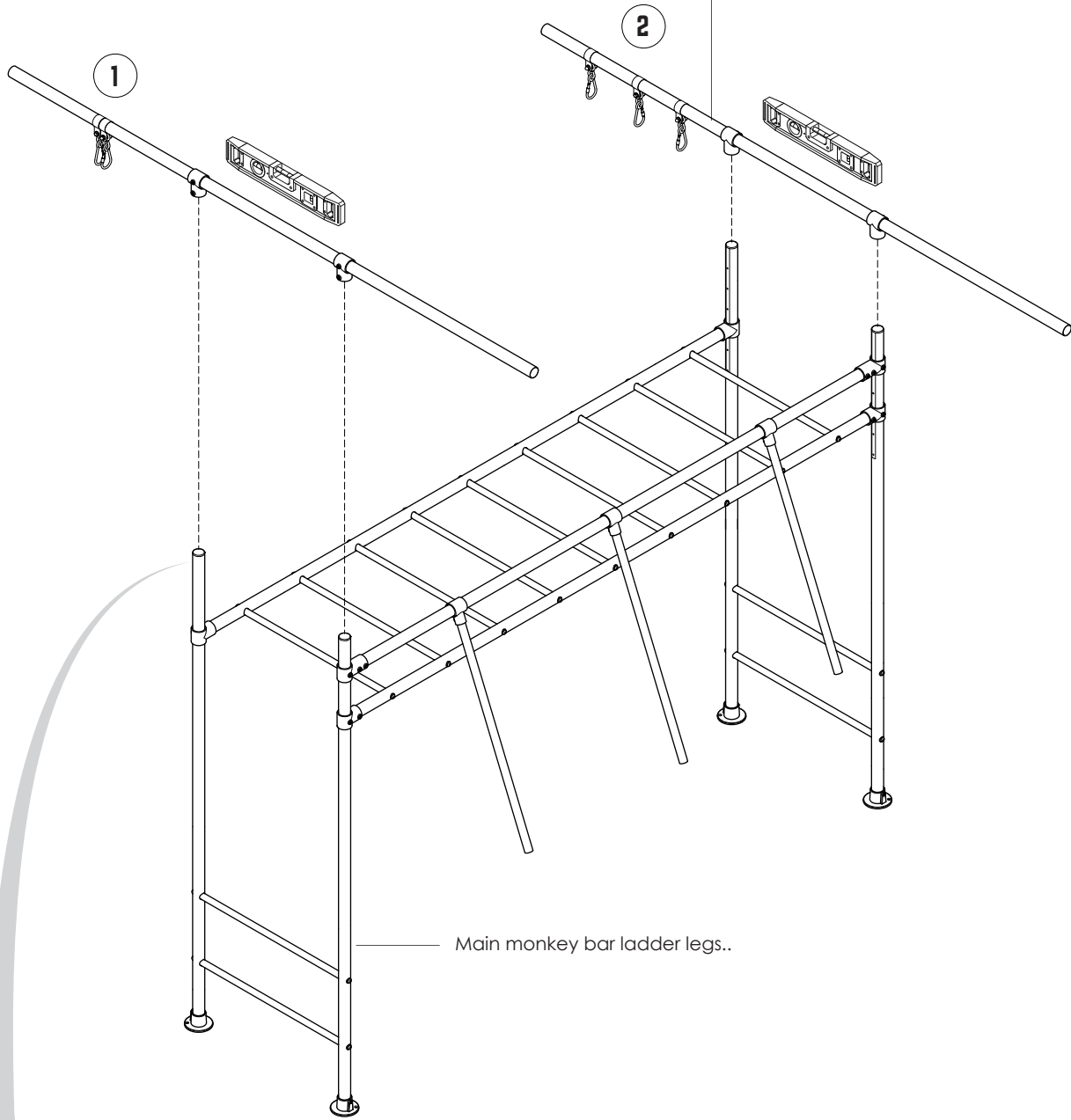

Fully tighten all grub screws on all short tees.

ASSEMBLY INSTRUCTIONS - SWING LEG ASSEMBLY

23 ASSEMBLE SWING BAR LEGS X2

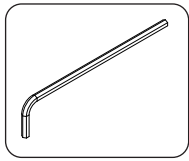

1. On flat level ground slide on all fittings.
2. Firmly tighten elbow & base plate grub screws.
3. Leave short tee 'C and D' hand tight at approx. 950mm above base plate.
4. Position long short tee 'A and B' at selected height 'X' from step 20.

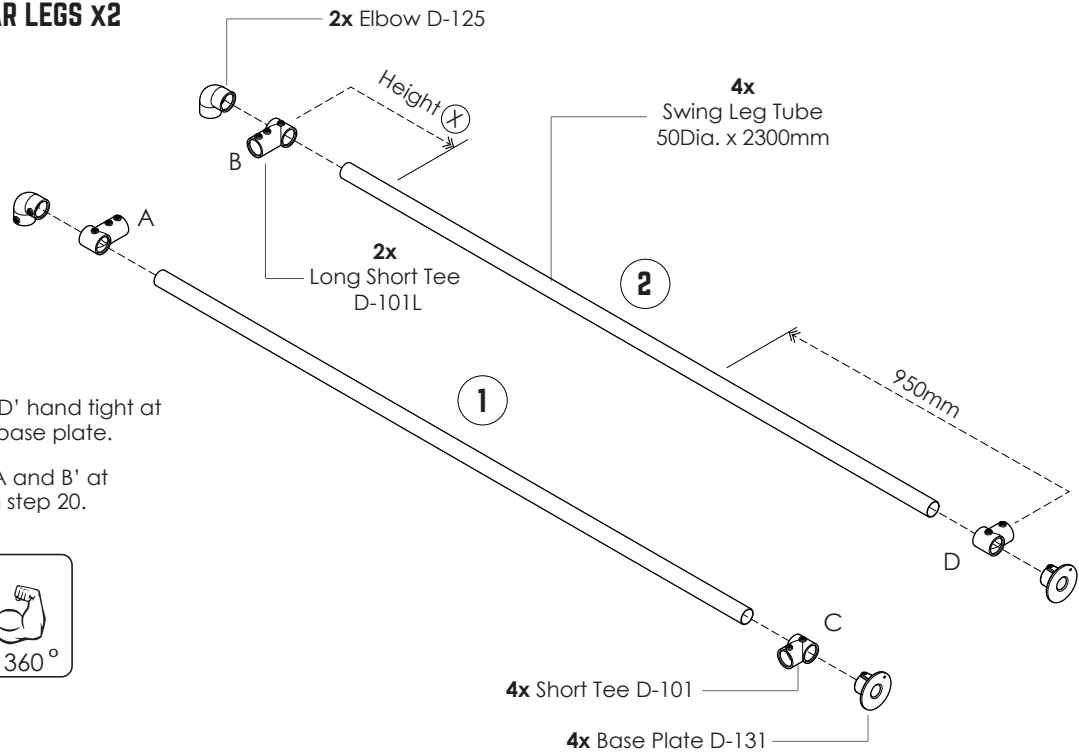
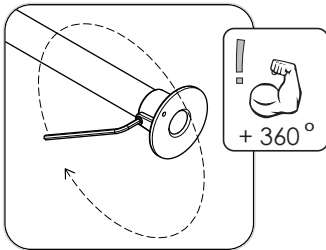

24 ASSEMBLE LEGS & ACCESSORIES BAR.

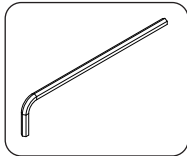

1. Slide 3x reducing tees onto accessories tube, spacing the same as the other lache accessories tube in step 19. Ensure the grub screws are facing the base plates on the legs.
2. Fully tighten all grub screws.

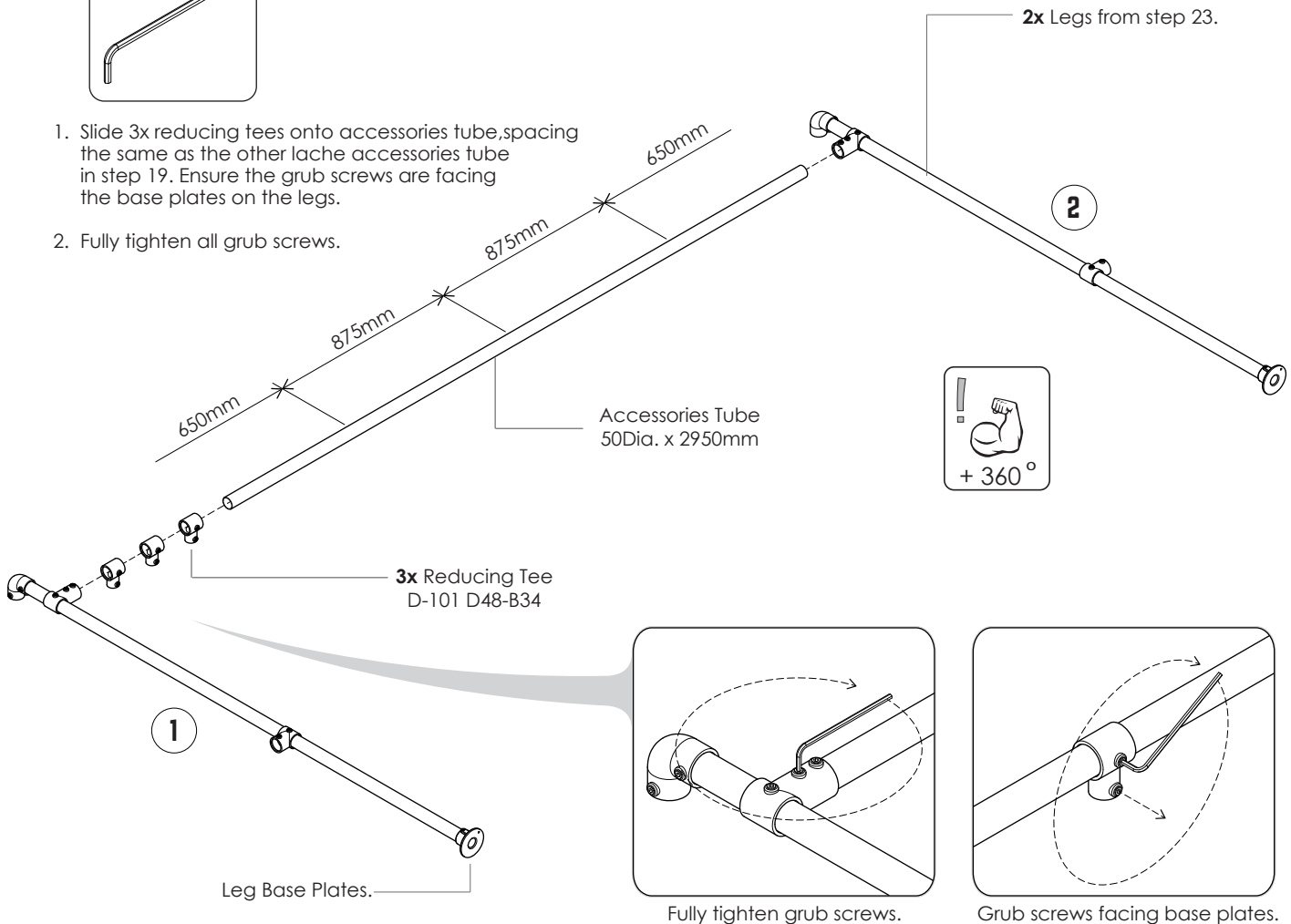

25 ATTACH SWING LEG ASSEMBLY

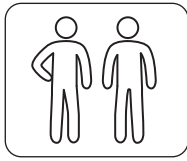
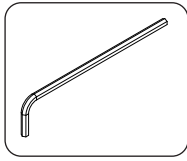

1. With 2 people slide leg assembly onto double swing bar ends (lache tube side).
2. At the same time swivel the lache tubes into position in the leg assembly reducing tees.
3. Fully tighten all grub screws.

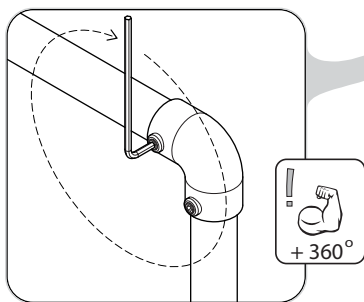
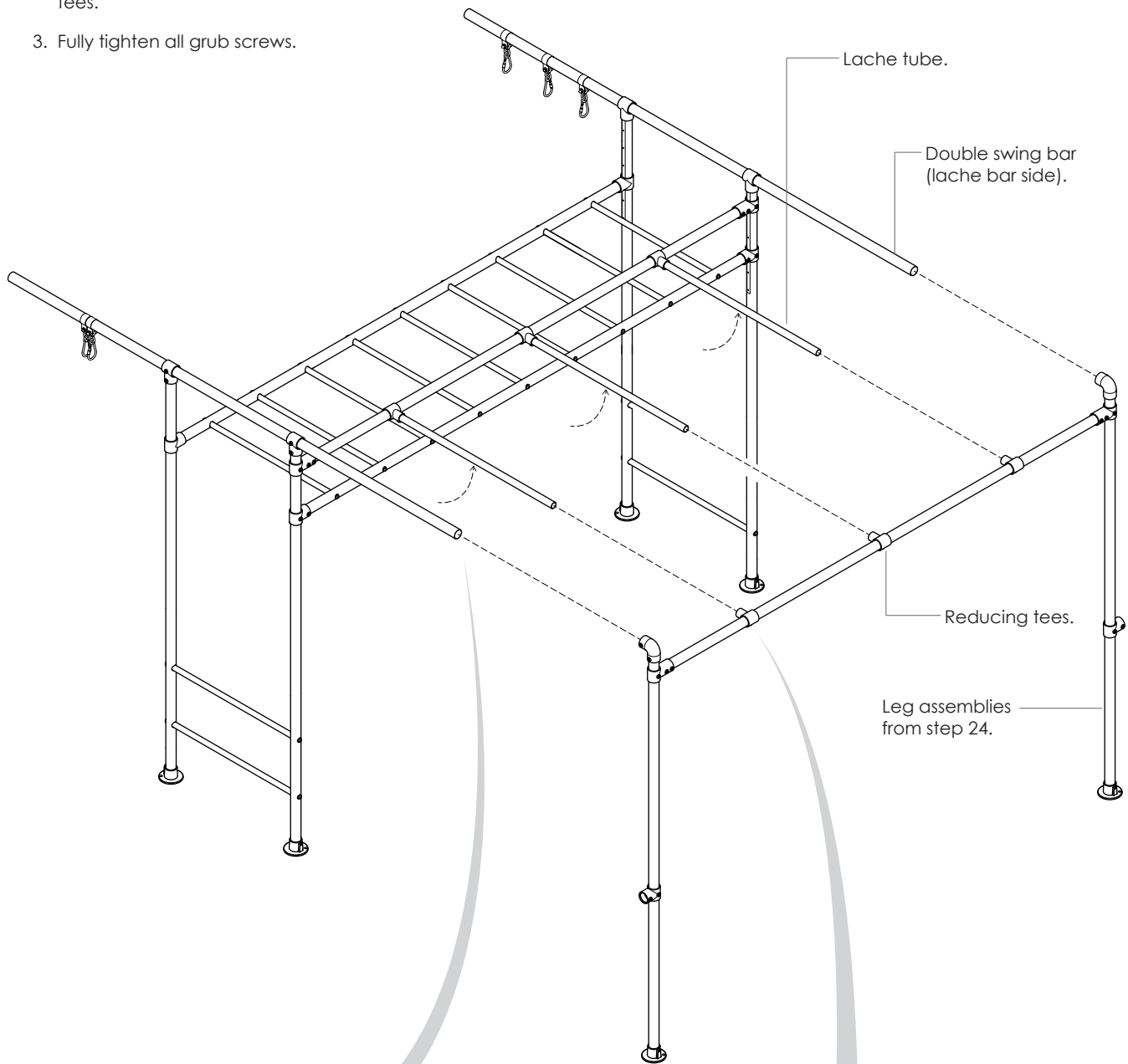

Fully tighten all grub screws.

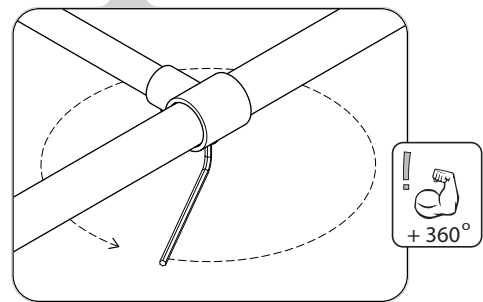

Fully tighten all grub screws.

26 SECURE TO GROUND

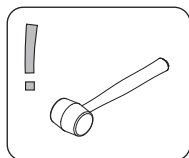
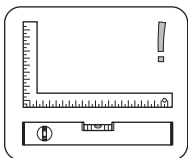

1. Check frame is level and square.
2. Ensure all grub screws are firmly tightened.
3. Hammer in pegs x2.

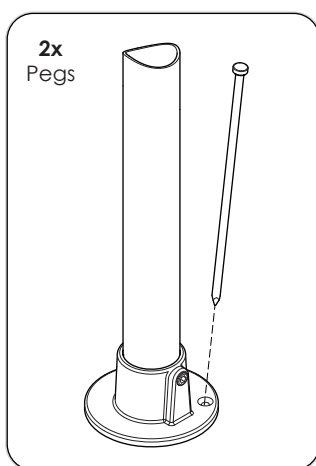
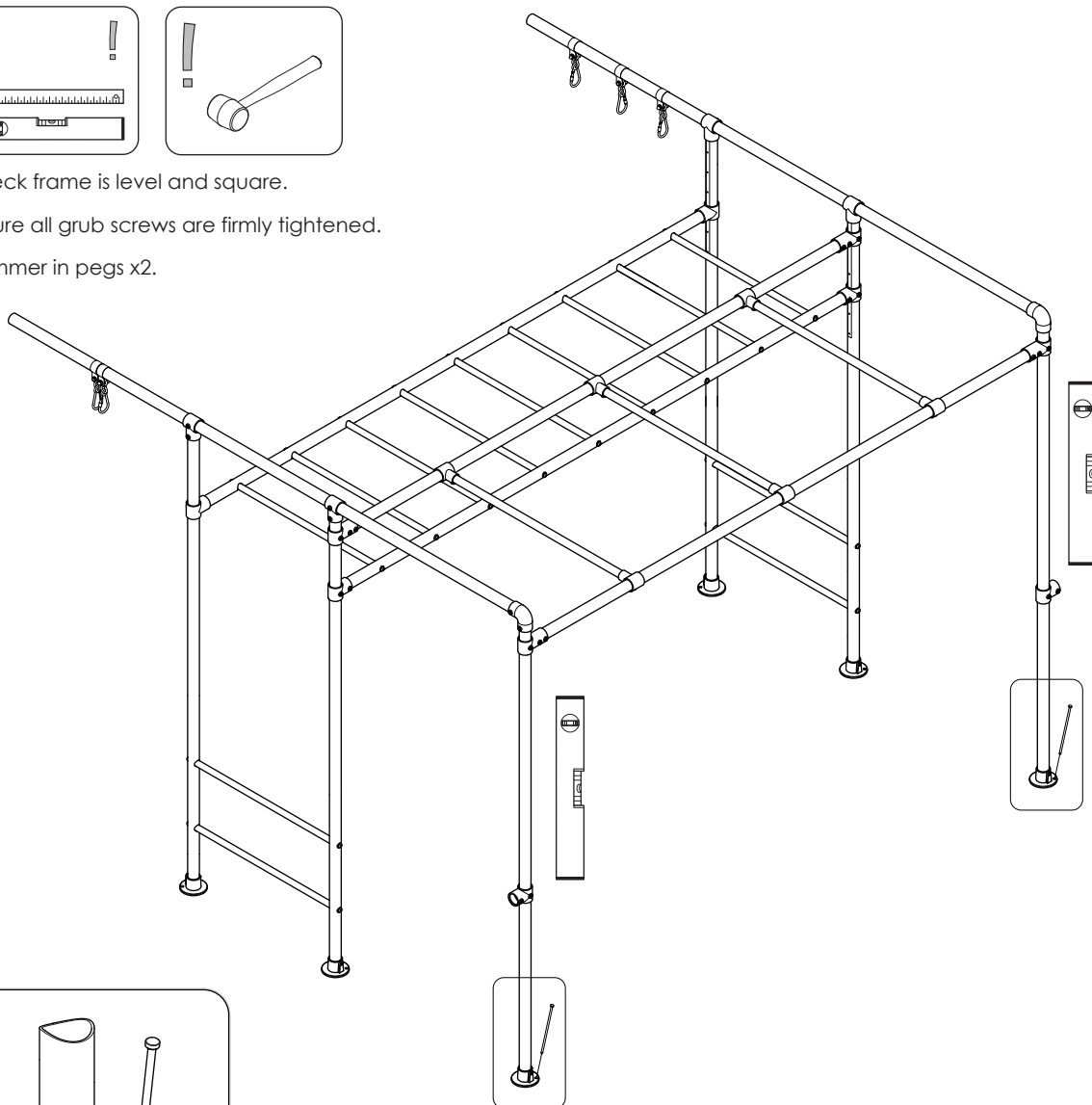

27 THE FOLLOWING STEPS ARE PERFORMED ON THE OTHER SIDE OF THE FRAME.
FOR DRAWING CLARITY THE VIEW WILL BE ON THE OTHER SIDE FROM HERE ON FORTH.

28 ATTACH ACCESSORIES SUPPORT TUBE

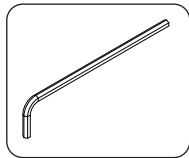

1. On flat level ground feed the accessories tubes through the long side cargo net hoops. Slide long short tees onto the ends of the accessories tubes.
2. Ensure the long short tees are correctly fitted.
3. Leave grub screws hand tight only

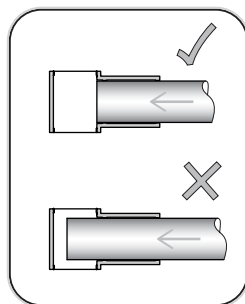

Ensure accessories tube is not over inserted into extra long tees & is level with through hole.

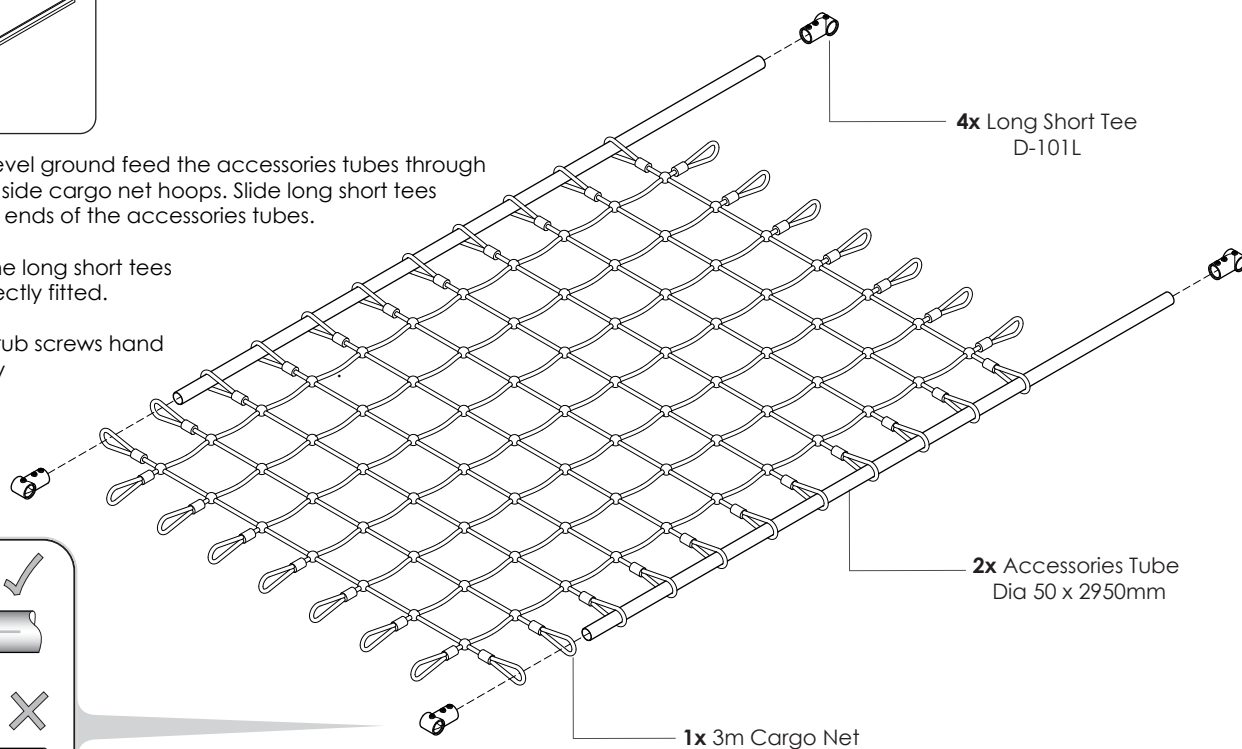

29 ATTACH CARGO LEG TUBES

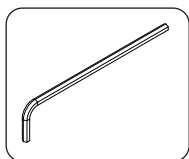

1. Feed the leg tubes through the accessories support tube long short tees, side cargo net hoops and short tees A & B. A & B (located between cargo hoops 2 & 3)
2. Attach elbows and base plates. Ensure they are fully inserted and fully tighten grub screws.
3. Ensure the elbows and top accessories support tube C are hard up together.
4. Fully tighten all grub screws. (Leave grub screws on D & E loose).

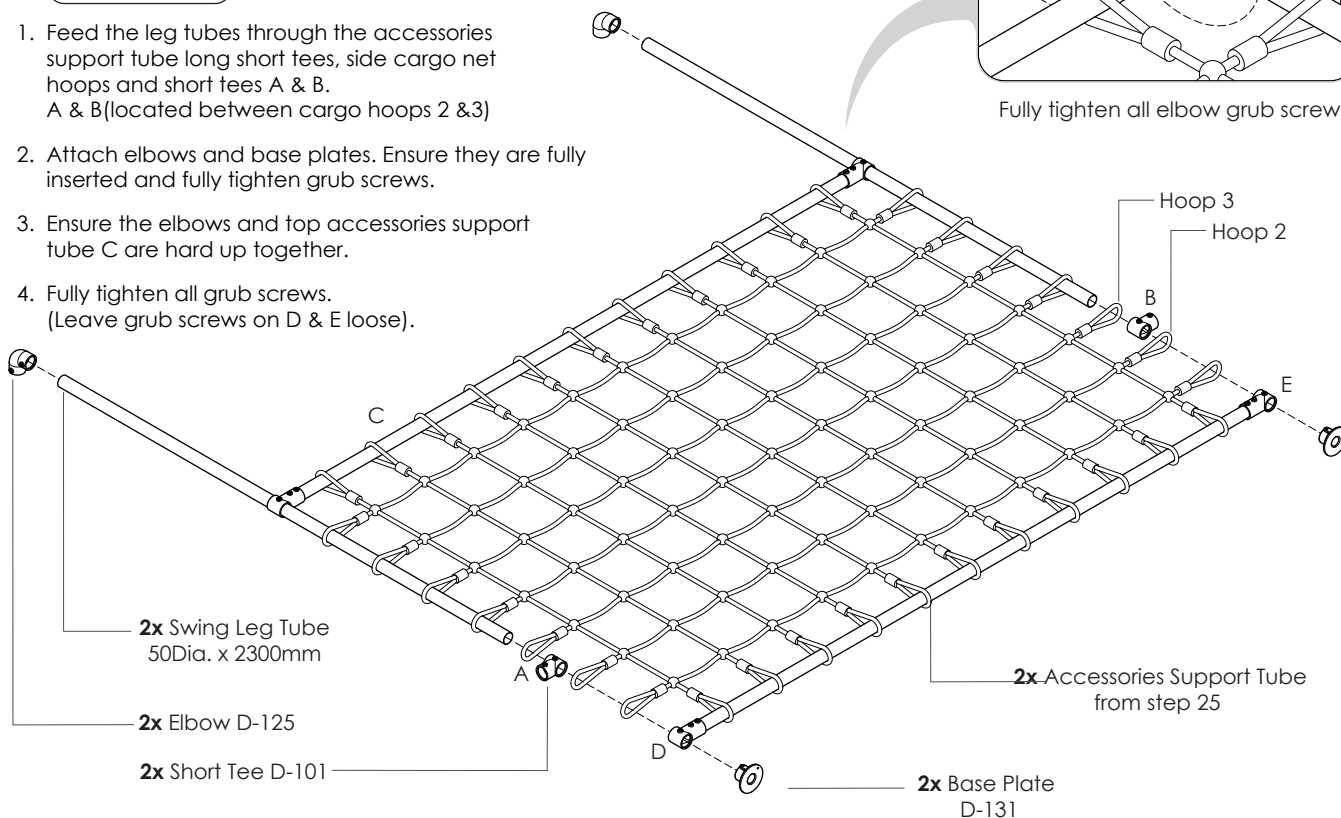
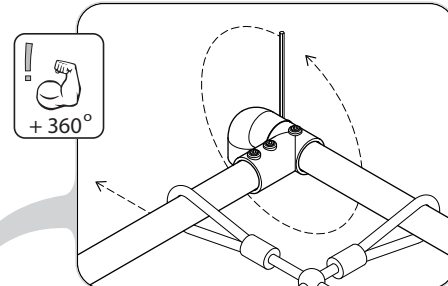

30 ATTACH CARGO NET INTO POSITION

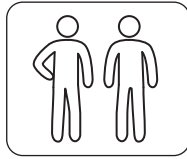
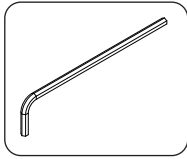

1. With 2 people lift the cargo net frame into position and fully insert elbows into the double swing bar ends.
2. Fully tighten all grub screws.

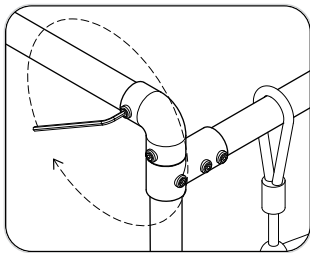
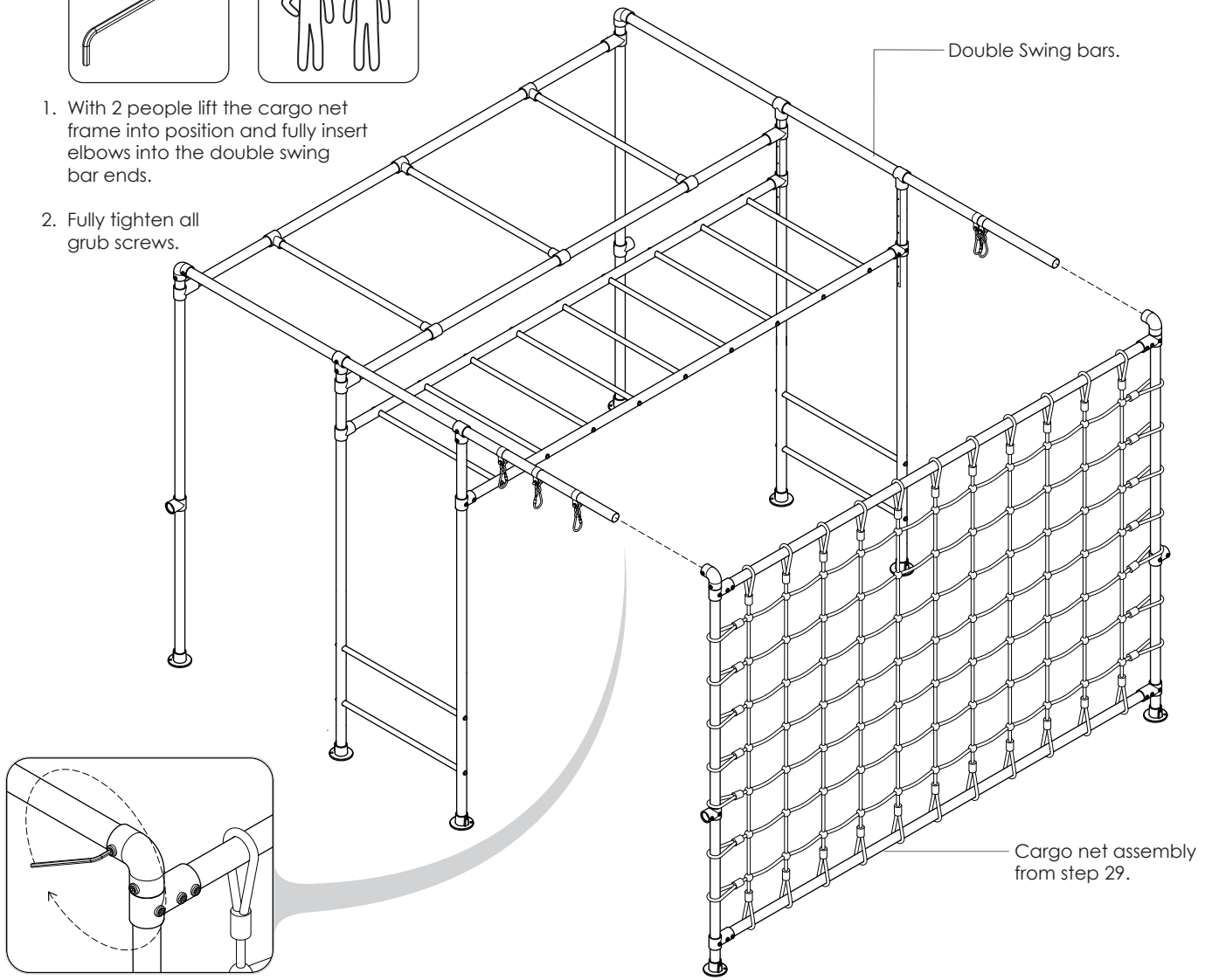

31 SECURE TO GROUND

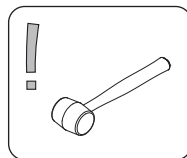
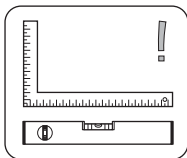

1. Check level and square.
2. Hammer in pegs x2.

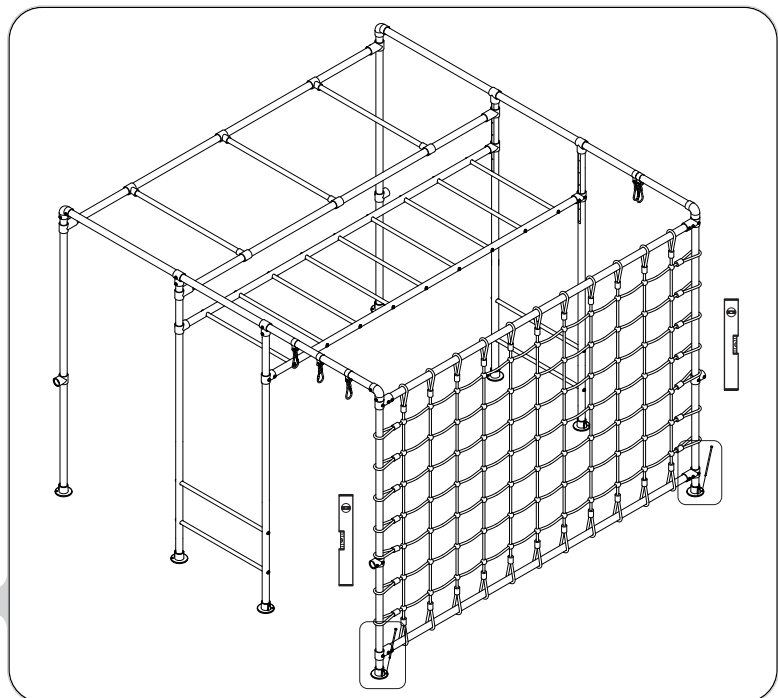
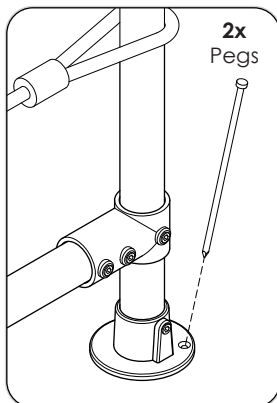

32 TIGHTEN CARGO NET

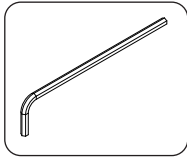

1. Loosen outside grub screws on long short tees A & B connecting to leg.
2. Get a second person to stand on lower tube to make cargo net taught and level.
3. Fully tighten all grub screws on long short tees A & B.
4. Check all other grub screws are tight.

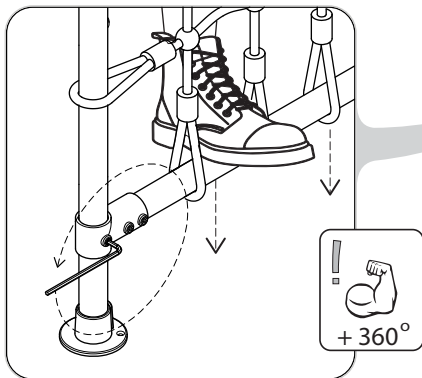
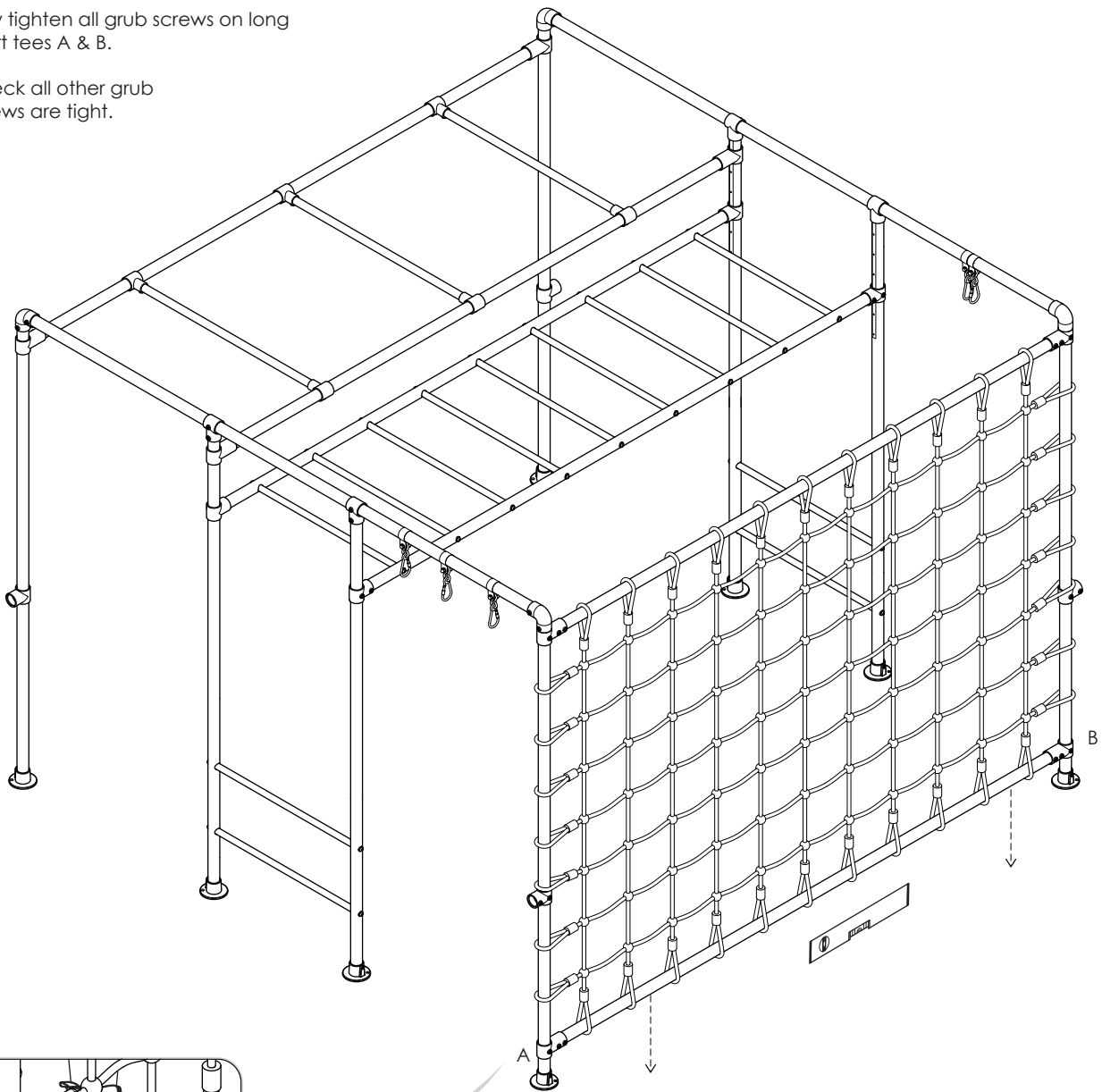

ASSEMBLY INSTRUCTIONS - TWIRLY WHIRLY BAR ASSEMBLY

33 ASSEMBLE VERTICAL TWIRLY TUBE

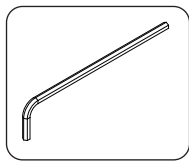

Tighten all grub screws.



1x
Elbow
D-125



1x
Twirly Tube
50Dia x 900mm



1x
Base Plate
D-131

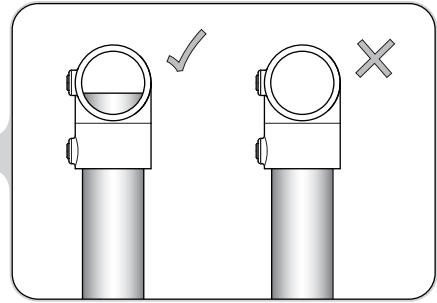

Insert Twirly Tube fully into Elbow.

34 ATTACH HORIZONTAL TWIRLY TUBE

Fully insert twirly tube then firmly tighten all grub screws.

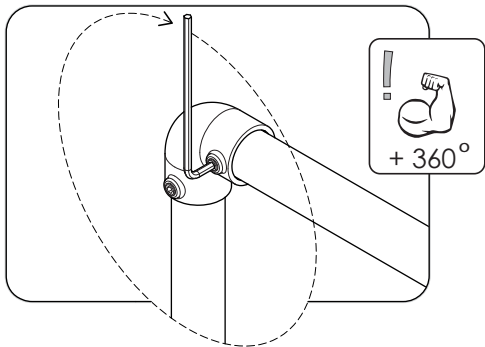

1x
Twirly Tube
50Dia x 900mm

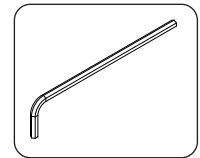

35 REPEAT STEPS 34 - 35 FOR 3 MORE TWIRLY WHIRLY BARS.

36 TWIRLY WHIRLY BAR x4

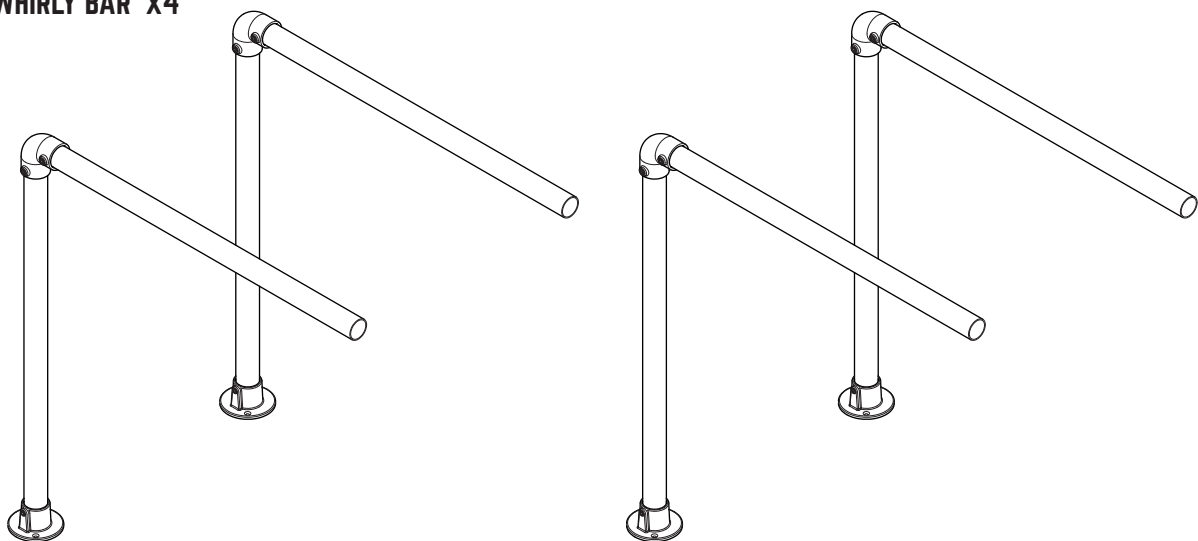

37 ATTACH TWIRLY WHIRLY BARS x4

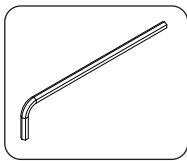

1. Adjust & rotate short tees A,B,C & D to align level with twirly whirly bars.
2. Tighten all grub screws fixing twirly whirlys to legs.

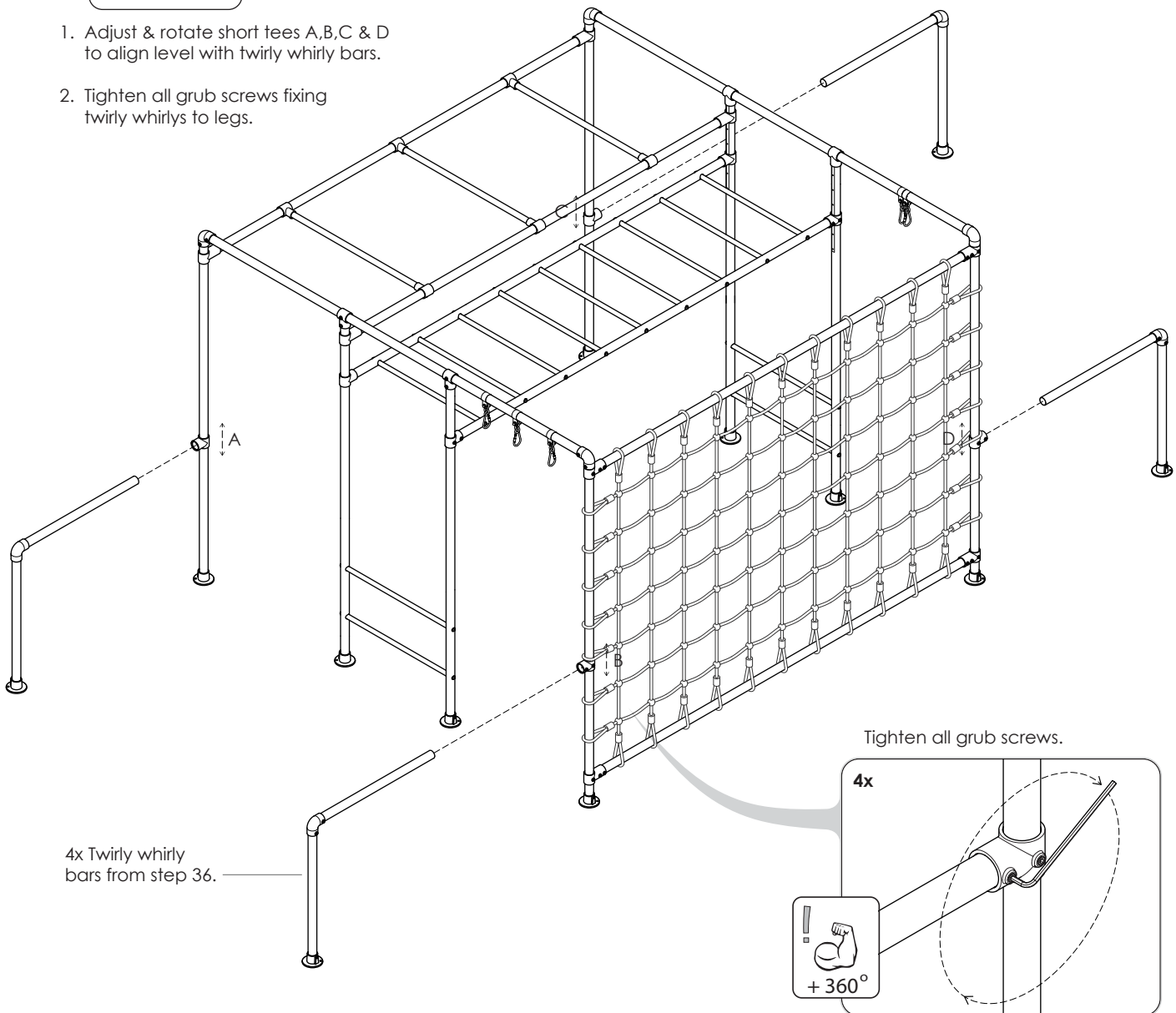

38 CHECK ALL FITTING GRUB SCREWS ARE FULLY TIGHTENED

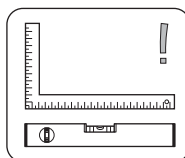
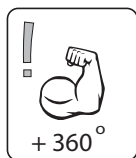
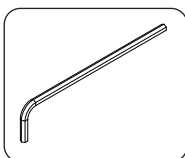

1. Ensure frame is square and level.
2. Firmly tighten all grub screws and bolts.

39 LOAD YOUR TWIRLY WHIRLY BARS x4

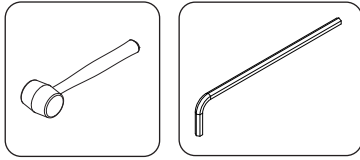

To reduce movement in your frame load your twirly whirly bars as follows.

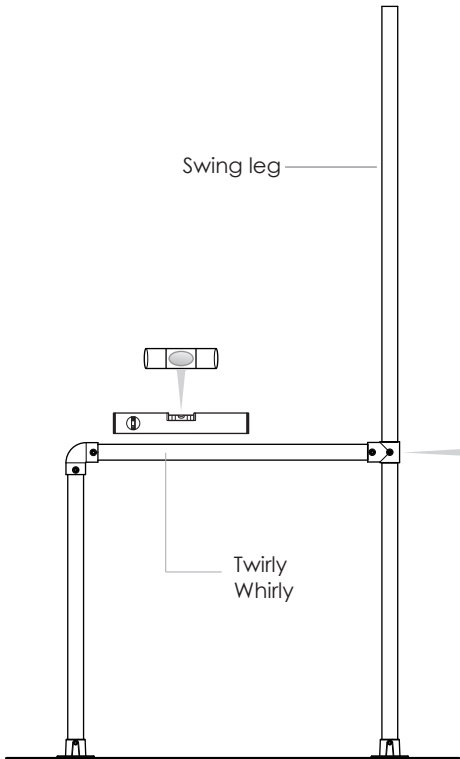

1. Ensure twirly whirly is level and square & swing leg is pegged down.

2. Loosen the grub screw fixing the short tee to the swing leg.

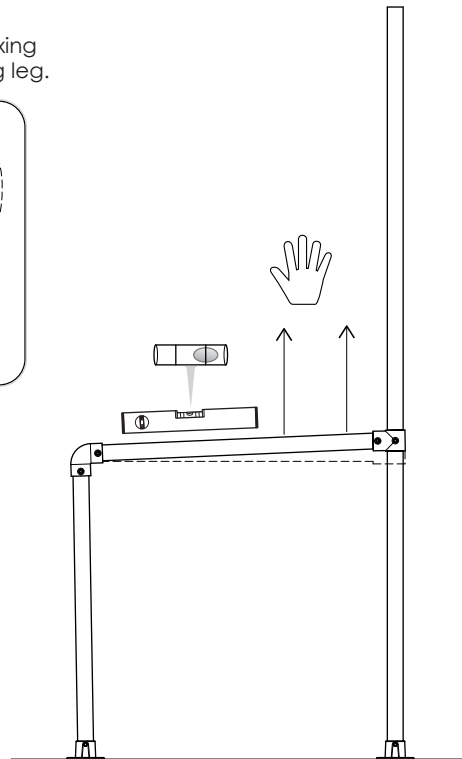
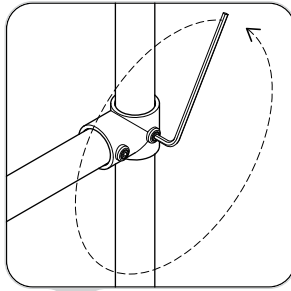

3. Pull upwards on the twirly whirly bar to make a slight angle. (Half a bubble off center on the level)

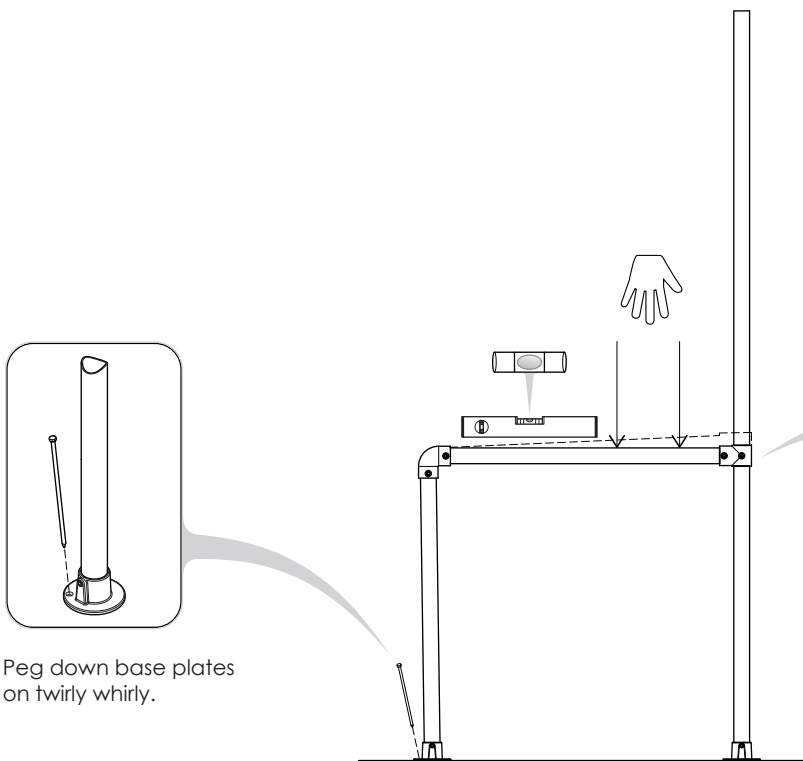

4. Peg down base plates on twirly whirly.

5. Push down on the twirly whirly bar until horizontal bar is level.

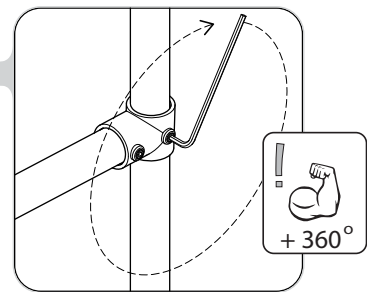

6. Tighten grub screw fixing the short tee to the swing leg tube. Apply to all twirly whirlys.

REFER TO VIDEO SECTION OF WEBSITE [HTTP://WWW.FUNKYMONKEYBARS.COM/PAGES/VIDEOS](http://www.funkymonkeybars.com/pages/videos)

40 ATTACH ACCESSORIES (IF APPLICABLE)

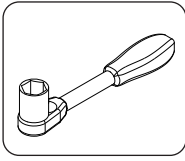

Attach new accessories in desired position (if applicable) and ensure swing hook bolts are tightened with a ratchet.

Rotate swing hooks 60° for horizontal rope before tightening bolts.

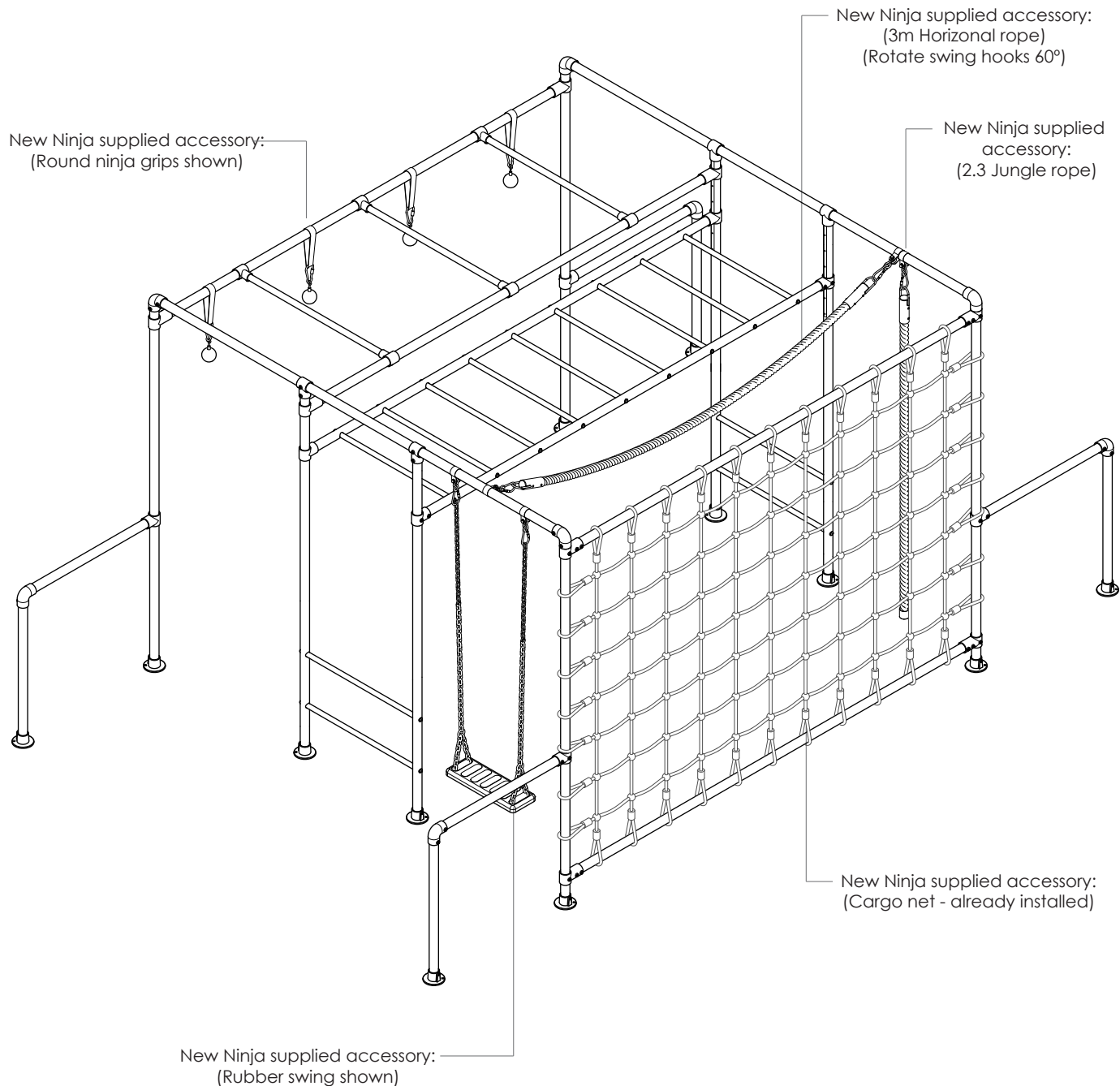

REFER TO SEPARATE ACCESSORIES INSTRUCTIONS IF APPLICABLE

One of the best things about Funky Monkey Bars® is the ability to add new equipment and accessories as your child and family grows. You can swap or add accessories to your existing frame, or add extra frames that will give you more versatility to attach equipment. Check out what we've got in store now at...

WWW.FUNKYMONKEYBARS.COM

46 FINAL CHECKS

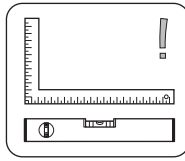
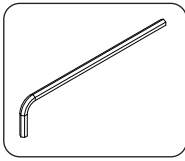

1. Ensure frame is square and level.
2. Firmly tighten all grub screws and bolts.
3. All base plates are pegged down.

47 MAINTENANCE.

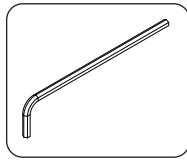
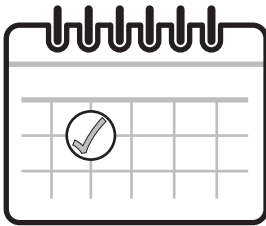

At the beginning of each heavy play session (especially a party) and twice a month during play season ensure;

1. Tighten all hardware - grub screws, nuts and bolts.
2. Pegs are in place and fully secure.
3. Lubricate all metallic moving parts with WD40 or Vaseline - (trolley and swing hooks.)
4. Ensure your frame is level and square.

FAILURE TO DO SO COULD RESULT IN SERIOUS INJURY OR DEATH.

**FOR MORE INFORMATION AND ASSEMBLY TIPS
PLEASE REFER TO OUR WEBSITE VIDEO INSTRUCTION SECTION AT
[HTTP://WWW.FUNKYMONKEYBARS.COM/PAGES/VIDEOS](http://www.funkymonkeybars.com/pages/videos)**

48 HAVE FUN





ABN 72 164 496 520



1300 912 198



info@funkymonkeybars.com



www.funkymonkeybars.com



9 Cutting Way,
Yangebup WA 6164



WE ARE SOCIAL MONKEYS



Australian Government
IP Australia

All Funky Monkey Bars® designs are registered and protected under IP Australian certification.