

# FUNKY Monkey bars®

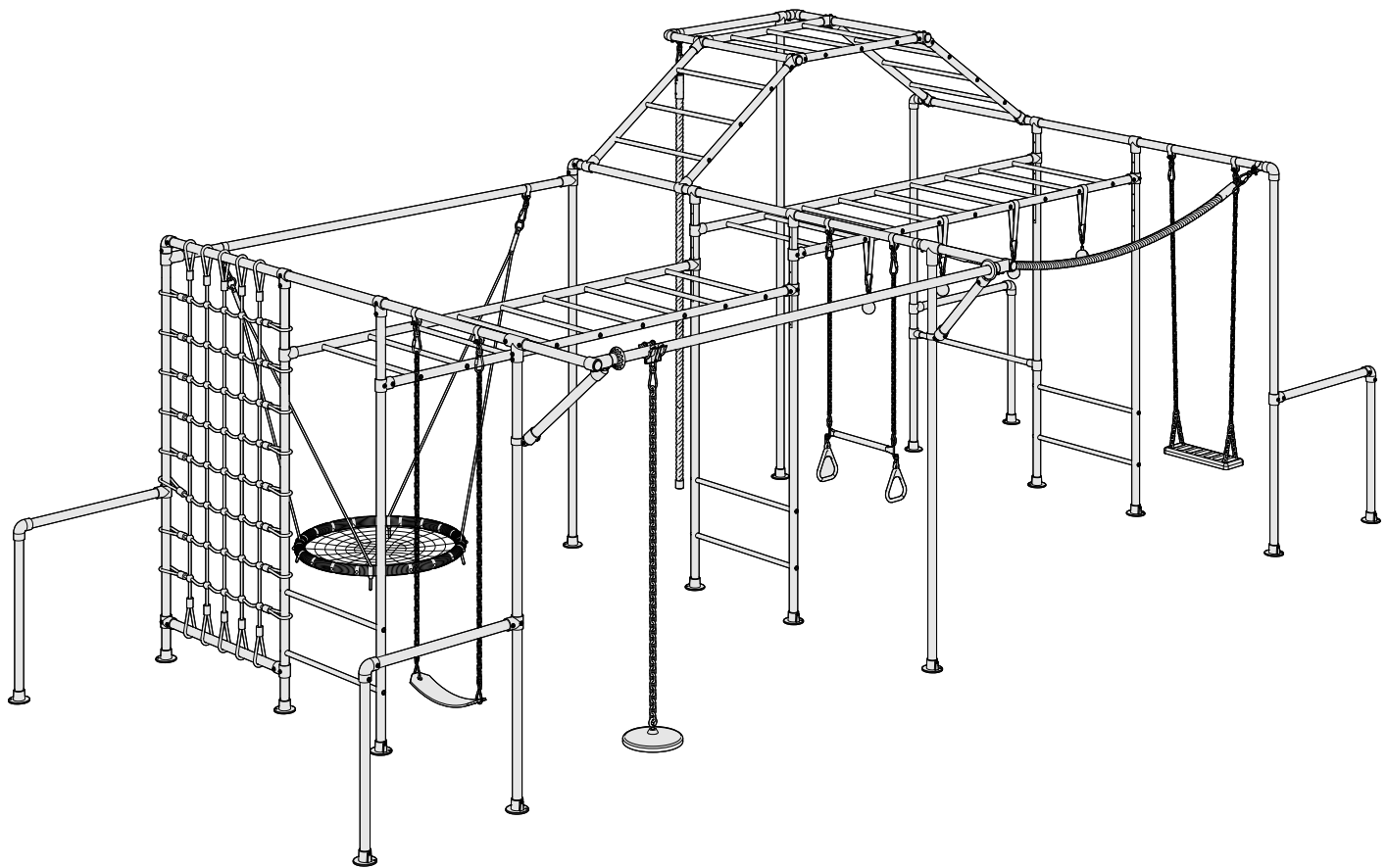

## THE MANDRILL PLUS ASSEMBLY INSTRUCTIONS

## CONTENTS

Warnings . . . . .	Page 1
Load Rating . . . . .	Page 3
Dimensions . . . . .	Page 4
Assembly Tips . . . . .	Page 5
Inventory . . . . .	Page 7
Assembly Instructions . . . . .	Page 10
Ladder Bar Assembly . . . . .	Page 10
Combat Ladder Bar Assembly . . . . .	Page 13
Leg Assembly . . . . .	Page 15
Twirly Whirly Bar Assembly . . . . .	Page 20
Main Monkey Bar Assembly . . . . .	Page 21
Swing Bar Assembly . . . . .	Page 25
Swing Leg Assembly . . . . .	Page 28
Floating Flying Fox Assembly . . . . .	Page 30
Combat Ladder Assembly . . . . .	Page 34
Load Twirly Whirly Bars . . . . .	Page 40
Maintenance . . . . .	Page 42

## WARNING

PLEASE CAREFULLY READ ALL INFORMATION CONTAINED IN THIS ASSEMBLY MANUAL BEFORE YOU INSTALL AND USE YOUR FUNKY MONKEY BARS®.

## SAFETY NOTICE

1. Any person handling or using the Funky Monkey Bars® products must follow the instructions as described in this document. The person in charge of assembling and using the equipment must ensure that the recommendations for use given in this document are seen by all users.
2. Only use the Funky Monkey Bars® after they have been fully assembled and after checking that the fittings are tightened properly (*refer to page 5 - Correct Tightening Method*).
3. DO NOT install your Funky Monkey Bars® over concrete, asphalt, packed earth, wood decking or any other hard surface. A fall onto a hard surface can result in serious injury or death.
4. Inspect all grub screws, bolts and nuts at the beginning of each play session to ensure your Funky Monkey Bars® are tight and secure.
5. Ensure all tubes are fully inserted into fittings until you hear the magic "CLUNK" sound.
6. Ensure your Funky Monkey Bars® are properly secure at ALL times. Pegs are in place and inserted fully into the ground.
7. DO NOT exceed the maximum load/weight limit as recommended by Funky Monkey Bars®.
8. Children should be supervised by an adult at all times.
9. Installing a gym/crash mat under the fall zone area of your Funky Monkey Bars® would be recommended for children learning this new skill. This will reduce the chance of injury and build the child's confidence while they build strength and master the skill.
10. Ensure you have thoroughly read your assembly and installation instructions and viewed our on-line installation videos at <https://www.funkymonkeybars.com/blogs/installation-maintenance-videos>
11. DO NOT climb, sit or stand on top of the monkey bar (horizontal ladder) section.
12. DO NOT jump from the top of any section of the monkey bar.
13. DO NOT use your Funky Monkey Bars® when wet as the steel will be slippery.
14. DO NOT attach items to your frame that are not designed specifically to be used with Funky Monkey Bars®, especially lower quality products that have not been approved by Funky Monkey Bars®.
15. Ensure the height of your Funky Monkey Bars® (horizontal ladder) are set at a level that is age appropriate.
16. DO NOT install your Funky Monkey Bars® over or near objects that could interfere with users in an unsafe way. Maintain a clear area around your Funky Monkey Bars®.
17. DO NOT use your Funky Monkey Bars® while under the influence of drugs and alcohol.
18. Wear clothing free of drawstrings, hooks, loops or anything that could get caught while using your Funky Monkey Bars® and result in entanglement and/or strangulation.

## ASSEMBLY

1. Keep small children away from the Funky Monkey Bars® during assembly.
2. Do not attempt to use the Funky Monkey Bars® until it is completely assembled and every fitting is tight and secured.
3. Installation typically takes 4-5 hours to complete. Two people are recommended for assembly.
4. Ensure all fittings are tightened to the correct tightening method as described on page 5.
5. Assembly should be carried out on clean, dry, level surface

Please refer to the video section on the Funky Monkey Bars® website for more handy tips and assembly instructions at <http://www.funkymonkeybars.com/pages/videos>

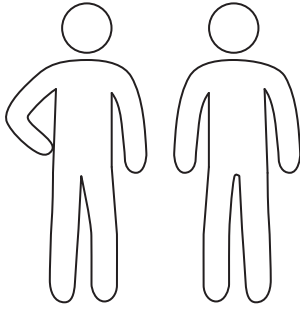

Assembly requires 2 adults.

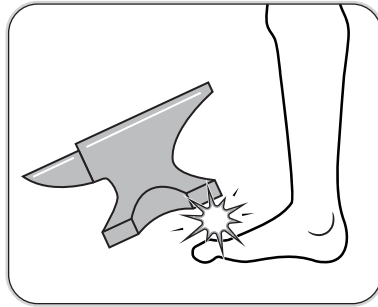

Heavy items !

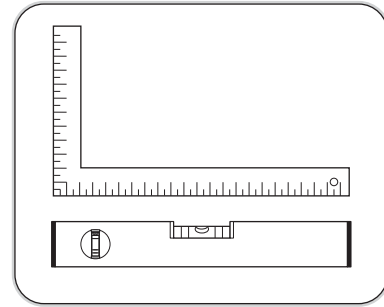

Work on flat level surface.

## LOCATION

1. A safe fall zone around your Funky Monkey Bars® is essential. A minimum distance of 1.5m to 2m (5 ft to 6.5ft) is recommended around the elevated hanging points of your Funky Monkey Bars®.
2. Place your Funky Monkey Bars® on level ground, away from any structure or obstruction such as a fence, garage, house, overhanging branches, laundry lines or electrical wires and remove any obstructions beneath your Funky Monkey Bars®.
3. Ensure your Funky Monkey Bars® are positioned away from retaining walls, pool fences, structures and other play equipment. Maintain a clear space around the whole perimeter of your Funky Monkey Bars®.
4. Place your Funky Monkey Bars® on the most level surface available.

## MAINTENANCE

1. At the beginning of each heavy play session we recommend the following maintenance processes be performed on your Funky Monkey Bars®:
  - Tighten all bolts, grub screws and applicable hardware (as per page 5)
  - Lubricate all metallic moving parts as per instructions (flying fox, swing hooks etc)
  - Check all protective coverings on bolts, pipes, edges and corners. Replace if they are loose, cracked or missing.
  - Check all moving parts including swing seats, shackles, snap hooks, chains and trolleys for wear, rust, or other deterioration. Replace as needed.
2. Twice a month during play season we would recommend the following maintenance processes be performed on your Funky Monkey Bars®:
  - Tighten all connections and hardware
  - Check all protective coverings on bolts, pipes, edges and corners. Replace if they are loose, cracked or missing.
3. Once a month during play season we would recommend the following maintenance processes be performed on your Funky Monkey Bars®:
  - Lubricate all metallic moving parts as per instructions (flying fox, swing hooks etc). If swings start to squeek then lubricate swing hooks.
  - Check all moving parts including swing seats, ropes, chains and trolleys for wear, rust, or other deterioration. Replace as needed.
  - Owners shall be responsible for maintaining the legibility of any warning labels.

For additional information concerning your Funky Monkey Bars®, please contact our customer service team or check our website for any important updates. Phone - 1300 912 198 or [www.funkymonkeybars.com](http://www.funkymonkeybars.com)



**QUALITY & INDEPENDENT TESTING**

At Funky Monkey Bars® we take the quality of our designs and safety very seriously. All Funky Monkey Bars® frames go through a stringent, independent structural testing process prior to being made available for release to our customers.

Our frames are designed within the parameters of the Australian Standard for Playground Equipment AS4685.1:2014.

The structural integrity of our frames has been tested for performance through a combination of engineering calculations and physical testing. The tests have been performed by independent, certified structural engineers in accordance with Australian Standard for Playground Equipment AS4685.1:2014 and European Standards EN1176-1:2008.

The independent testing conducted on The Mandrill Plus certified the frame to a load rating of 1620kgs or 27 users.

<b>LOAD TESTING CERTIFICATION</b>				
<b>DATE OF TEST</b>	<b>MODEL</b>	<b>NUMBER OF USERS</b>	<b>USER LOAD (KG)</b>	<b>LOAD RATING (KG)</b>
Aug 2018	Mandrill Plus	27	60	1620
I hereby confirm all testing was undertaken in accordance with Physical Testing of Structural Integrity requirements of AS 4685.1: 2014 App C / EN 1176-1:2008 <sup>o</sup> except where noted below;				
<b>COMMENTS:</b> The maximum number of users for the Floating Flying Fox is noted as 1 user. The maximum number of users on the Accessories Bar is noted as 3 users.(180kgs) The maximum number of users on the Combat Ladder is to be 4 users. (240kgs)				
<b>APPROVED BY:</b> Funky Monkey Bars®    <b>DATE :</b> Aug 2018			<b>WITNESSED BY:</b> Independent Engineer    <b>DATE :</b> Aug 2018	

# DIMENSIONS

## FUNKY MONKEY BARS® THE MANDRILL PLUS OVERALL DIMENSIONS

A minimum of 2.0 Metres clear fall zone is recommended around the elevated hanging points of your Funky Monkey Bars®.

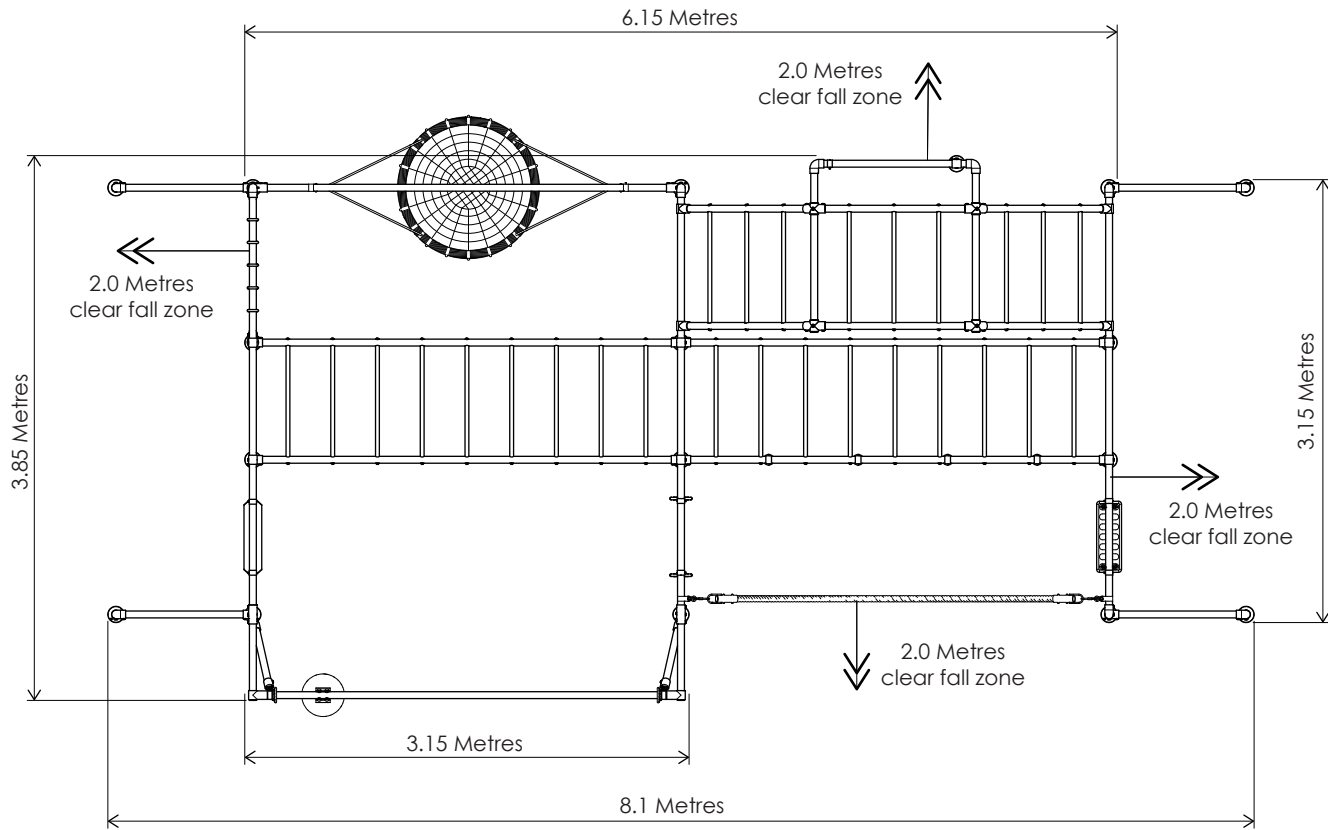

**PLAN VIEW**  
(not to scale)

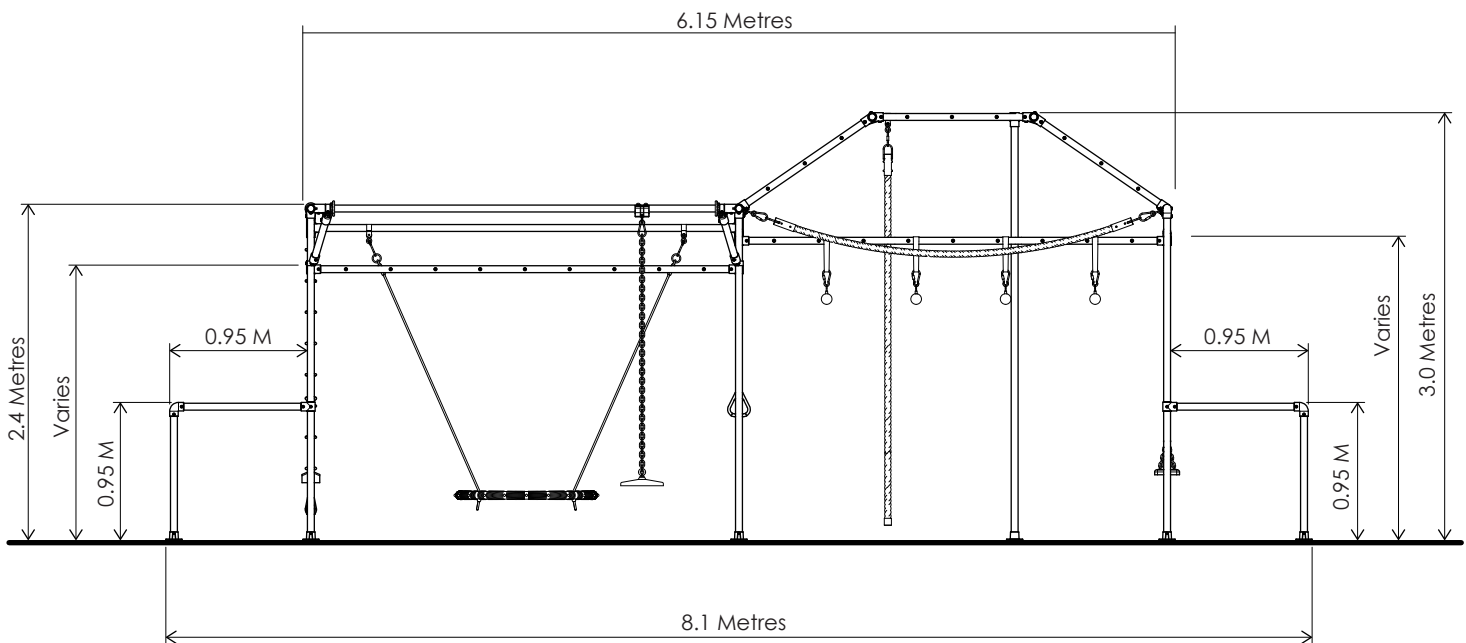

**SIDE VIEW**  
(not to scale)

## ASSEMBLY TIPS

### CORRECT INSERTION INTO FITTINGS - (INDICATIVE DIAGRAM SHOWN)

All tubes must be fully inserted until contact is made with adjoining tube.

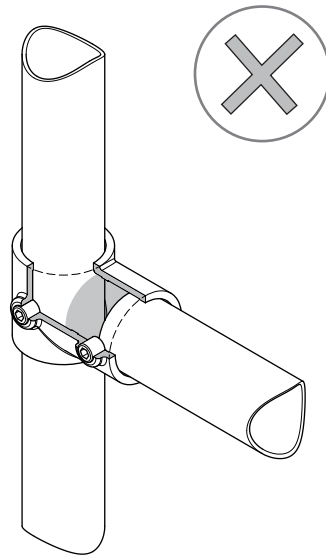

Gap.

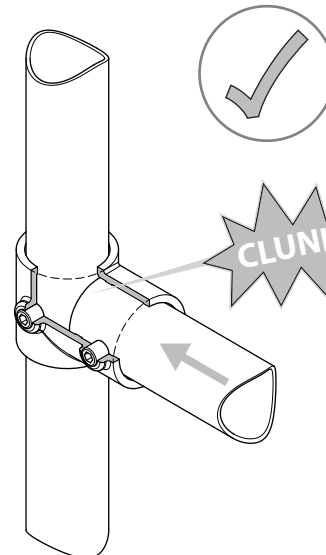

No gap.

### CORRECT TIGHTENING METHOD OF GRUB SCREWS - (INDICATIVE DIAGRAM SHOWN)

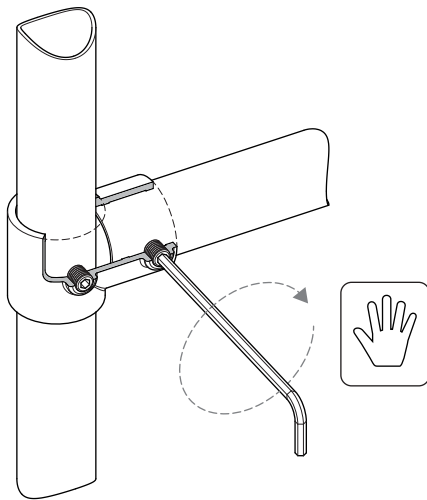

1. With long end of allen key, hand tighten grub screw as much as possible.

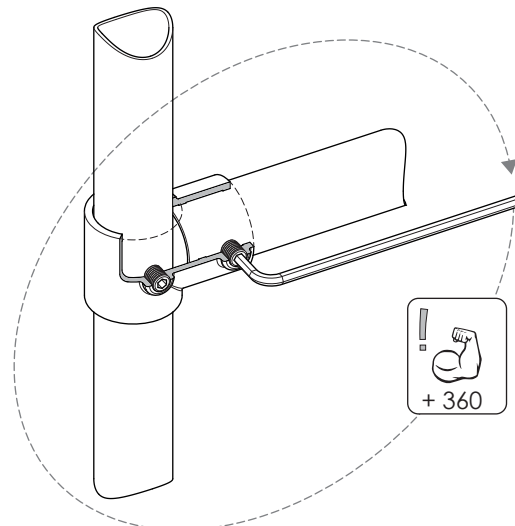

2. Using other end of the allen key do one full 360 degree turn as a minimum, use muscles!



### CORRECT TIGHTENING METHOD OF RUNG BOLTS - (INDICATIVE DIAGRAM SHOWN)

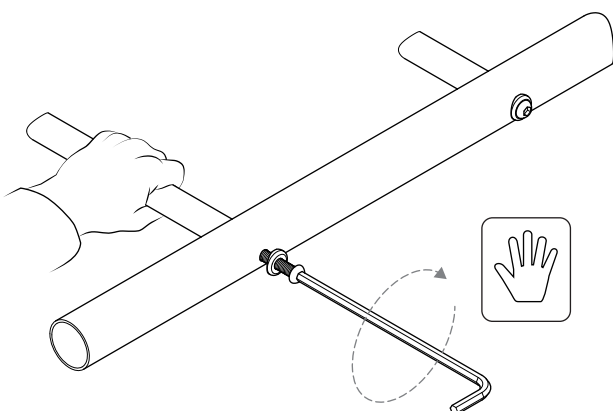

1. With long end of allen key, hand tighten bolt hard up against washer and outside of tube. Hold rung to avoid rotation.

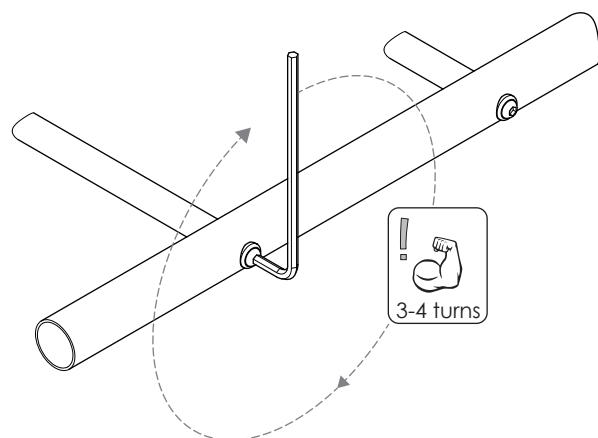

2. Using short end of the allen key fully tighten, approximately 3-4 full turns .



## ASSEMBLY TIPS (CONTINUED)

### IT IS CRITICAL YOUR MAIN FRAME IS 100% SQUARE AND LEVEL (INDICATIVE DIAGRAM SHOWN)

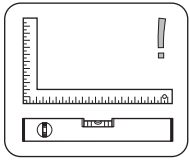

Check assembly is 100% level, square & straight.

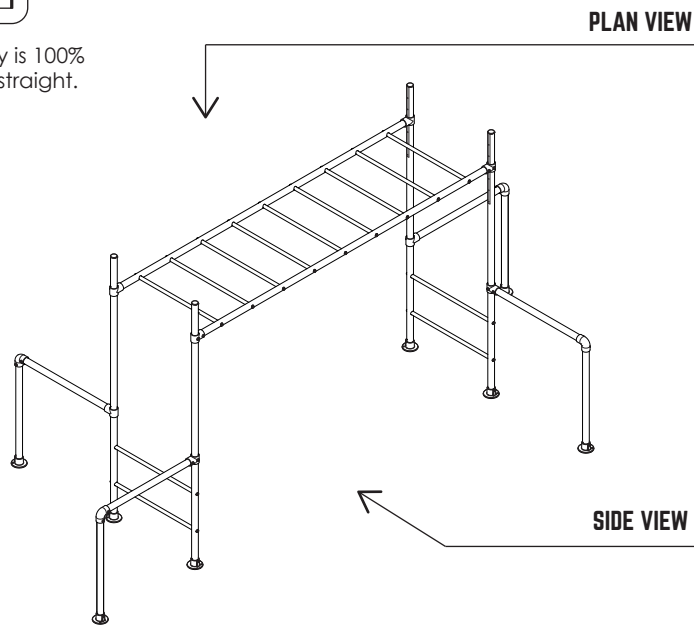

If your frame is not straight or level remove pegs, loosen grub screws, re-adjust re-tighten and re-peg the frame.

### INSTALLATION ON A SLOPE

If your frame is being installed on a slope ensure the monkey ladder bar is level. Either install at different heights on the legs or dig down at one end until level.

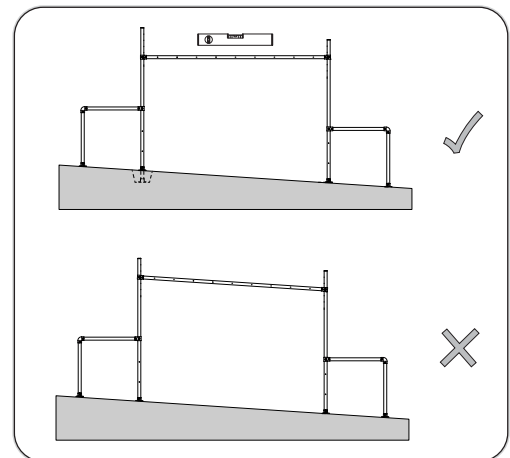
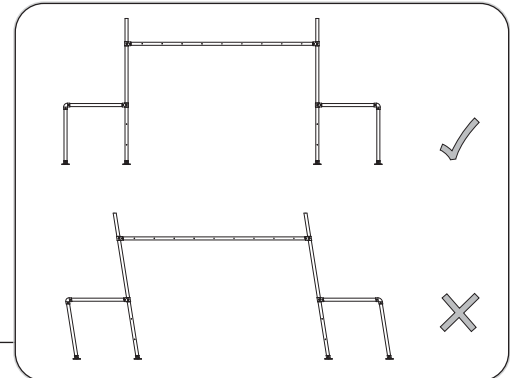
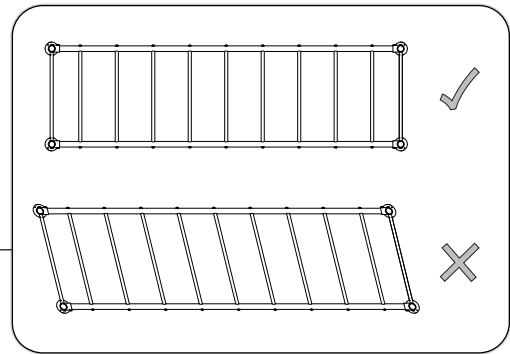

### FIXING TYPICAL ORIENTATION - (INDICATIVE DRAWING SHOWN)

Unless otherwise stated all grub screws and fittings should face downwards and outwards. This will reduce weathering damage, help with assembly and ease of maintenance.

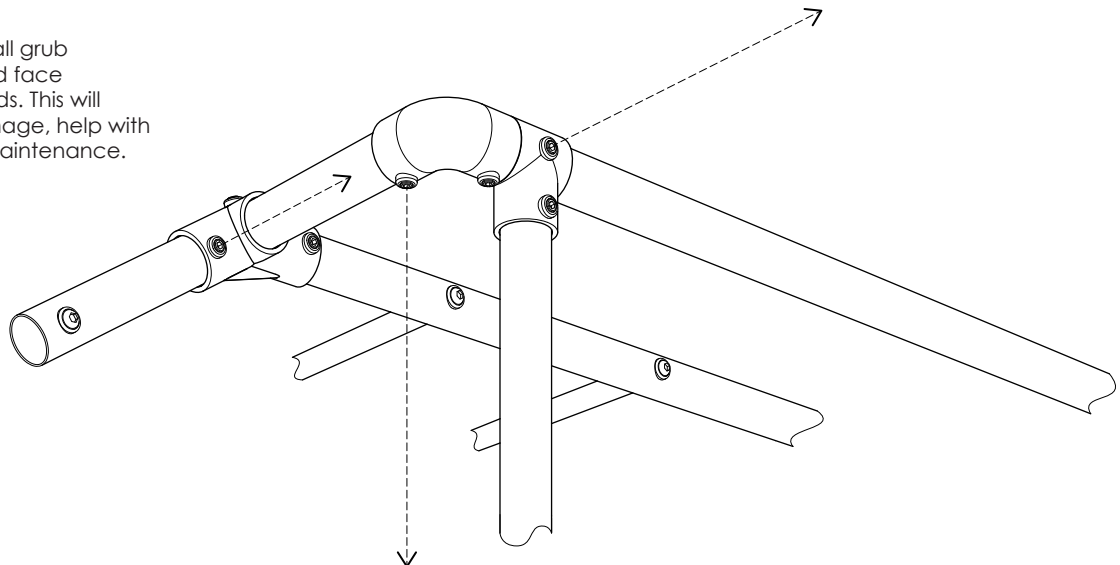

# INVENTORY

## TOOLS REQUIRED FOR INSTALLATION

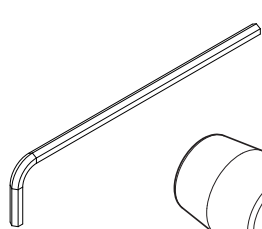

**1x**  
8mm Allen key  
(Included)

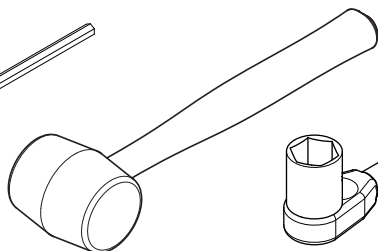

**1x**  
Soft Hammer  
(Not included)

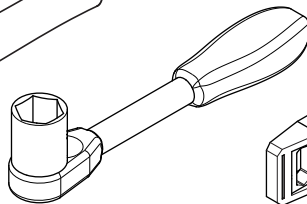

**1x**  
17mm Ratchet  
(Not included)

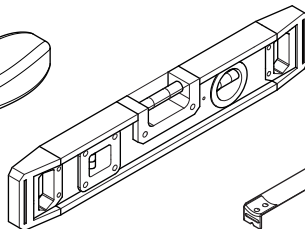

**1x**  
Spirit Level  
(Not included)

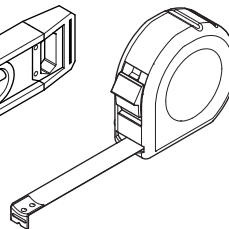

**1x**  
Tape Measure  
(Not included)

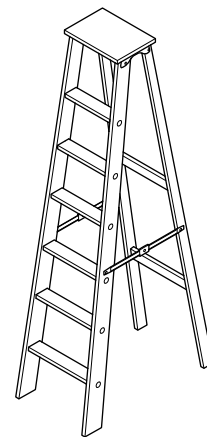

**2x**  
3m Step Ladder  
(Not included)

## TUBES

**33x**  
Rung Tube  
25Dia. x 850mm

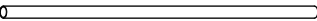

**1x**  
Step Tube  
33Dia. x 1040mm

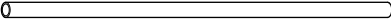

**4x**  
Brace Tube/  
Extension Tube  
50Dia. x 600mm

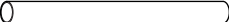

**8x**  
Twirly Tube  
50Dia. x 900mm



**1x**  
Cargo Tube  
50Dia. x 1040mm



**3x**  
Top Support  
Tube  
50Dia. x 1085mm



**6x**  
Combat  
Ladder tube  
50Dia. x 1085mm

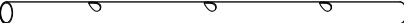

**6x**  
Swing Leg Tube  
50Dia. x 2300mm



**6x**  
Adj. Leg Tube  
50Dia. x 2300mm



**4x**  
Ladder Tube  
50Dia. x 2950mm



**6x**  
Double Swing Tube/  
Accessories Tube/  
Flying Fox Tube/  
Power Pole  
50Dia. x 2950mm





# INVENTORY (CONTINUED)

## FITTINGS

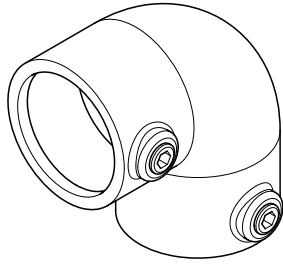

**10x**  
Elbow  
D-125

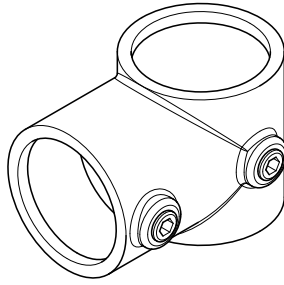

**25x**  
Short Tee  
D-101

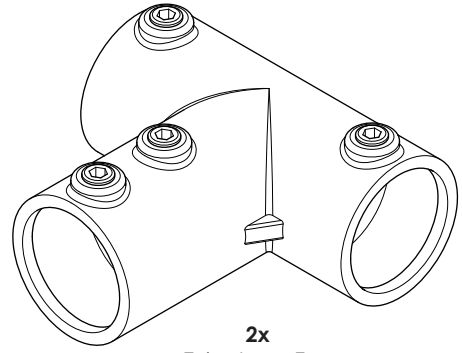

**2x**  
Extra Long Tee  
D-104L

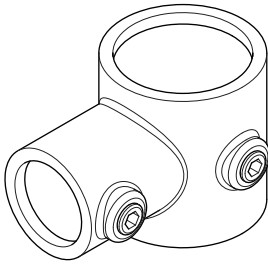

**2x**  
Reducing Tee  
D-101 D48-B34

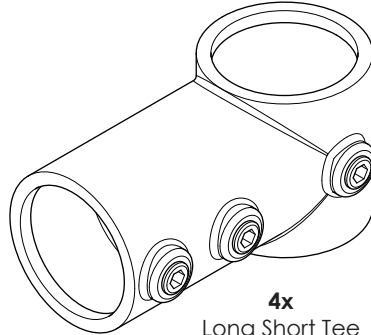

**4x**  
Long Short Tee  
D-101L

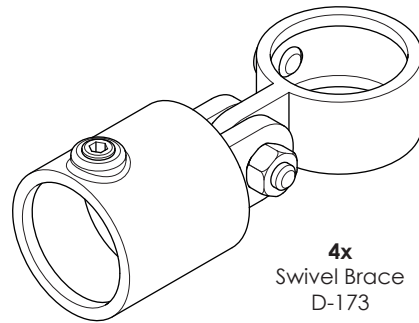

**4x**  
Swivel Brace  
D-173

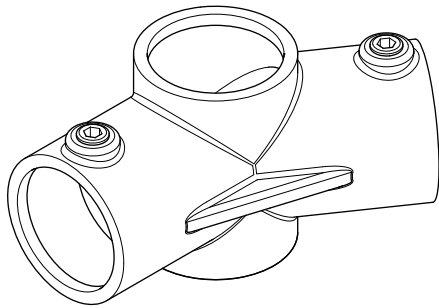

**4x**  
145° 3 Way  
D-120

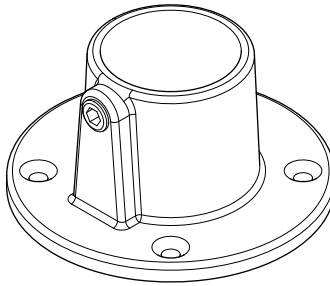

**1x**  
4 Hole Base Plate  
D-131

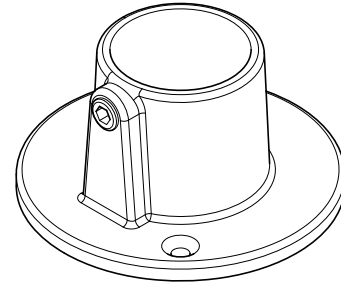

**16x**  
Base Plate  
D-131

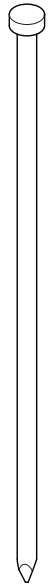

**20x**  
Peg

## HARDWARE

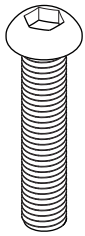

**73x**  
M10 Bolt

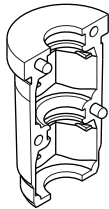

**146x**  
Rung Insert

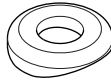

**73x**  
Washer



**146x**  
M10 Hex Nut

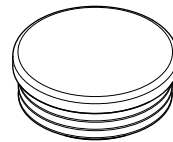

**10x**  
Plastic End Cap



**1x**  
Manufacture Sticker

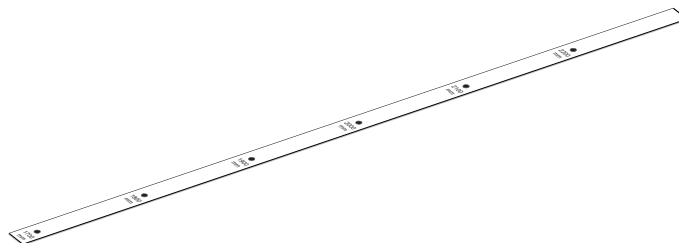

**6x**  
Height Sticker

# INVENTORY (CONTINUED)

## COMPONENTS (ACCESSORIES IF APPLICABLE)

11x  
Swing Hooks



1x  
Trolley

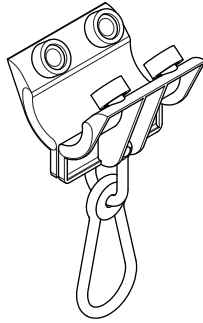

4x  
Ninja Grips  
(Round)



2x  
Rubber Stopper

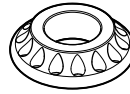

1x  
Trapeze

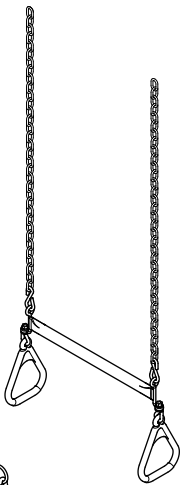

1x  
Sling swing

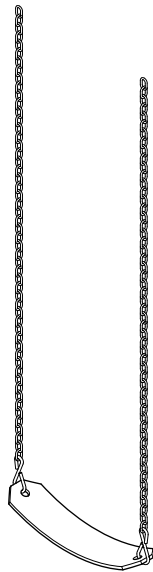

1x  
Rubber swing

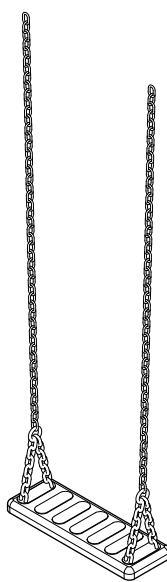

1x  
Button swing

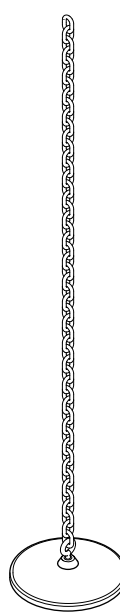

1x  
Cargo Net

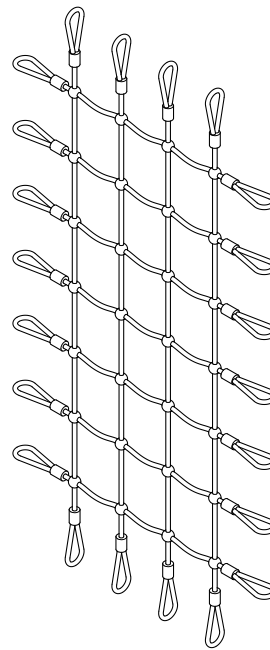

1x  
3m  
Jungle Rope



1x  
Nest swing

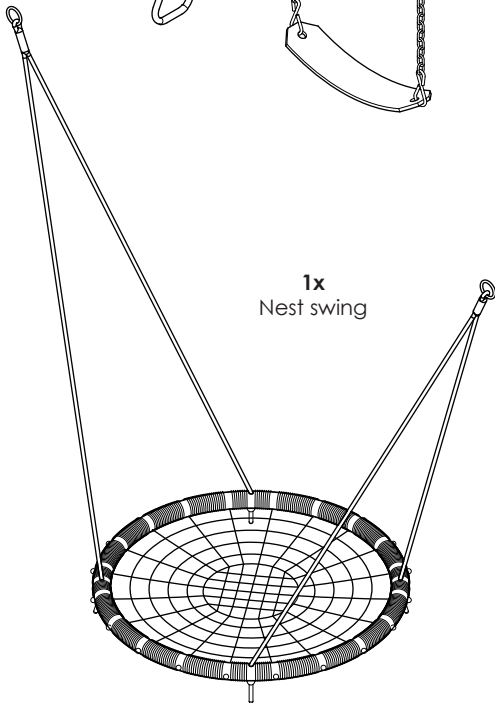

1x  
3m Horizontal Rope

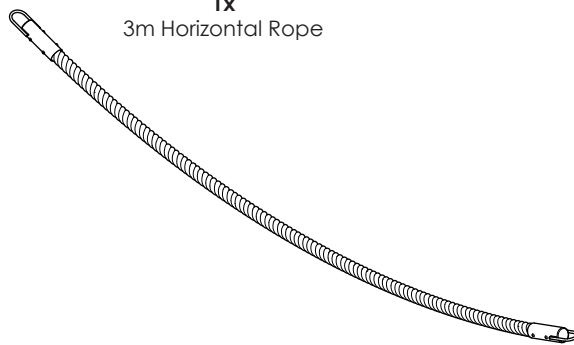

NOTE: Components not to scale.

One of the best things about a Funky Monkey Bar is the ability to add new equipment and accessories as your child and family grows. You can swap or add accessories to your existing frame, or add extra frames that will give you more versatility to attach equipment. Check out what we've got in store now at...

[WWW.FUNKYMONKEYBARS.COM](http://WWW.FUNKYMONKEYBARS.COM)

# ASSEMBLY INSTRUCTIONS - LADDER BAR ASSEMBLY

## 1 RUNG ASSEMBLY (X33)

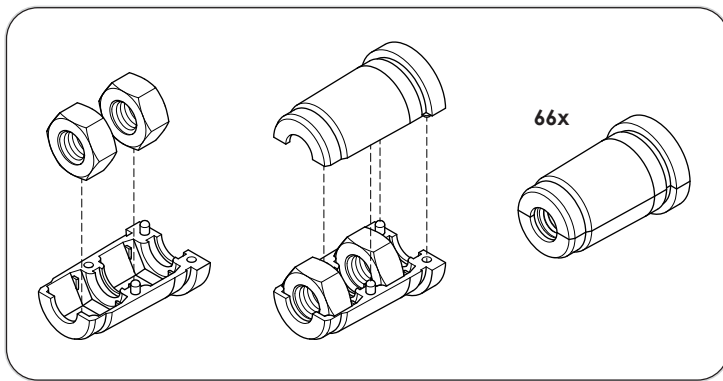

1. Assemble plastic rung inserts as shown above.

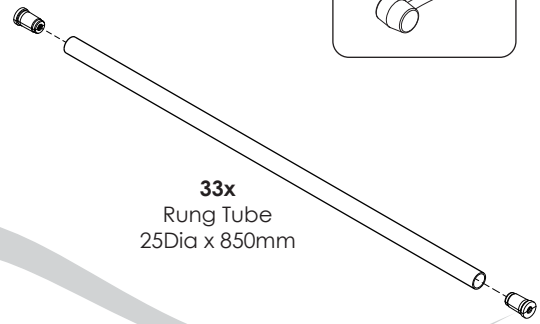

2. Push inserts into both ends of all rungs.

## 2 MONKEY BAR LADDER ASSEMBLY

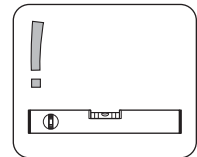
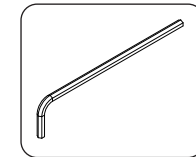
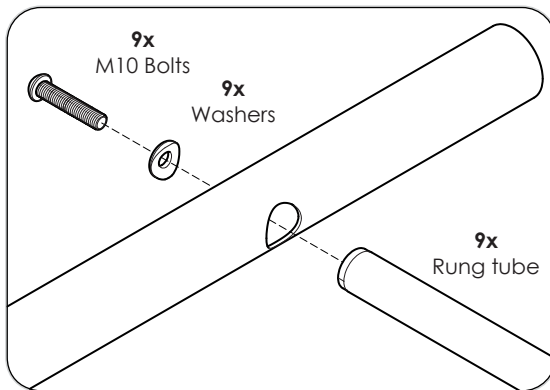

Hand tighten all bolts.

Assemble on flat surface.

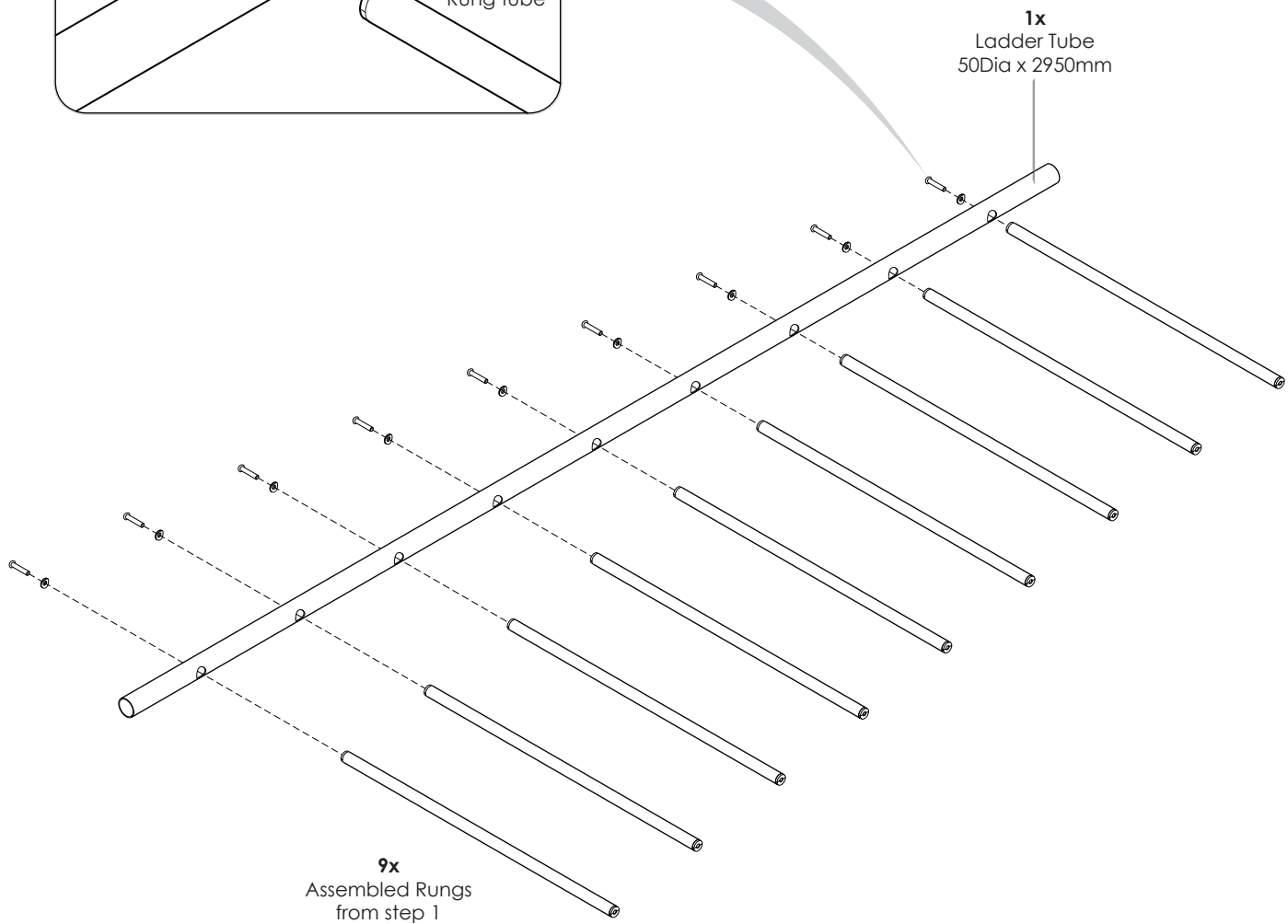

### 3 ATTACH SECOND LADDER TUBE

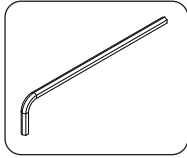

Hand tighten all bolts

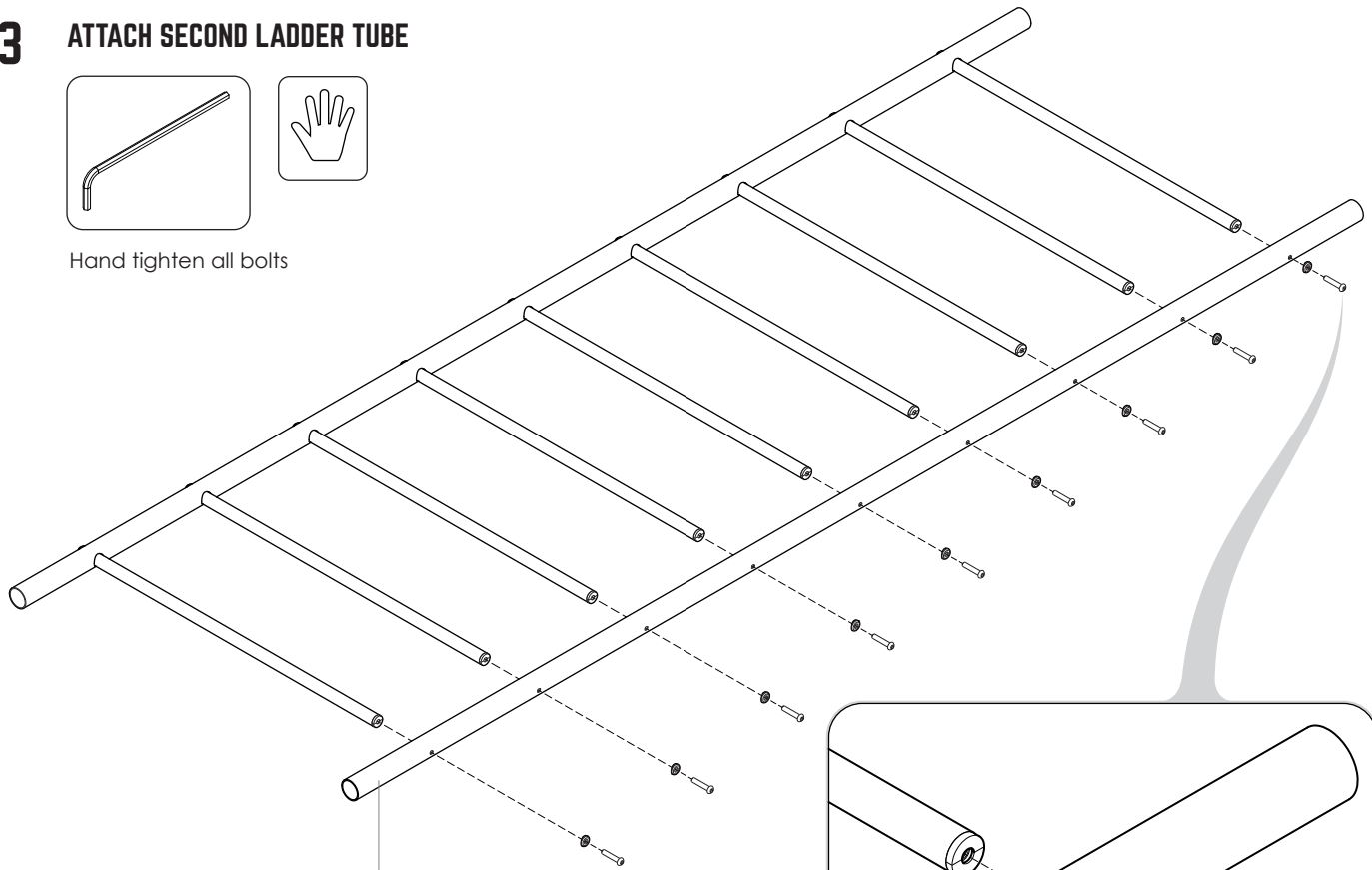

1x  
Ladder Tube  
50Dia x 2950mm

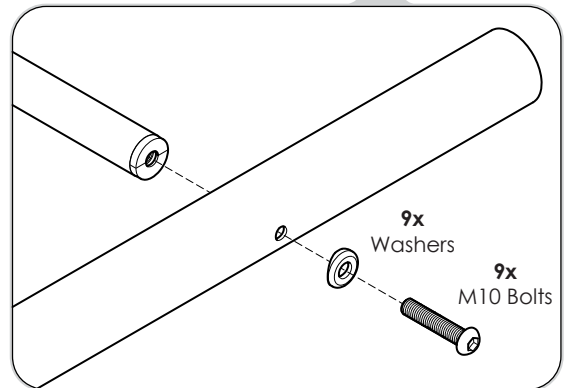

### 4 FIRMLY TIGHTEN ALL RUNG BOLTS.

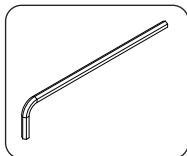

See page 5 for correct tightening method.

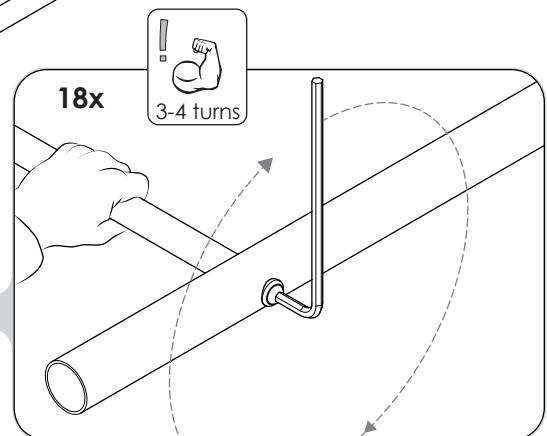
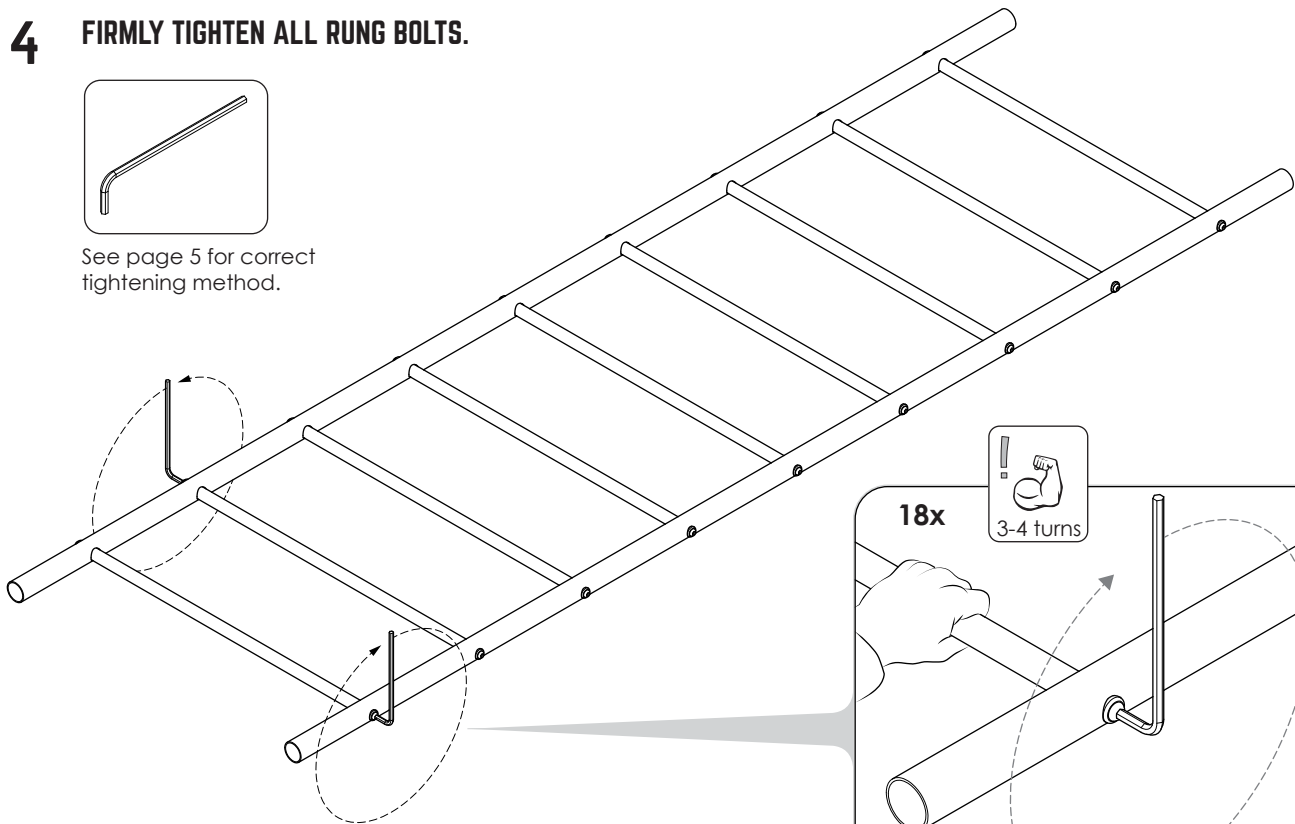

**5** REPEAT STEPS 2 - 4 FOR 1X MORE LADDER BAR ASSEMBLY.

**6** LADDER BAR ASSEMBLY X2.

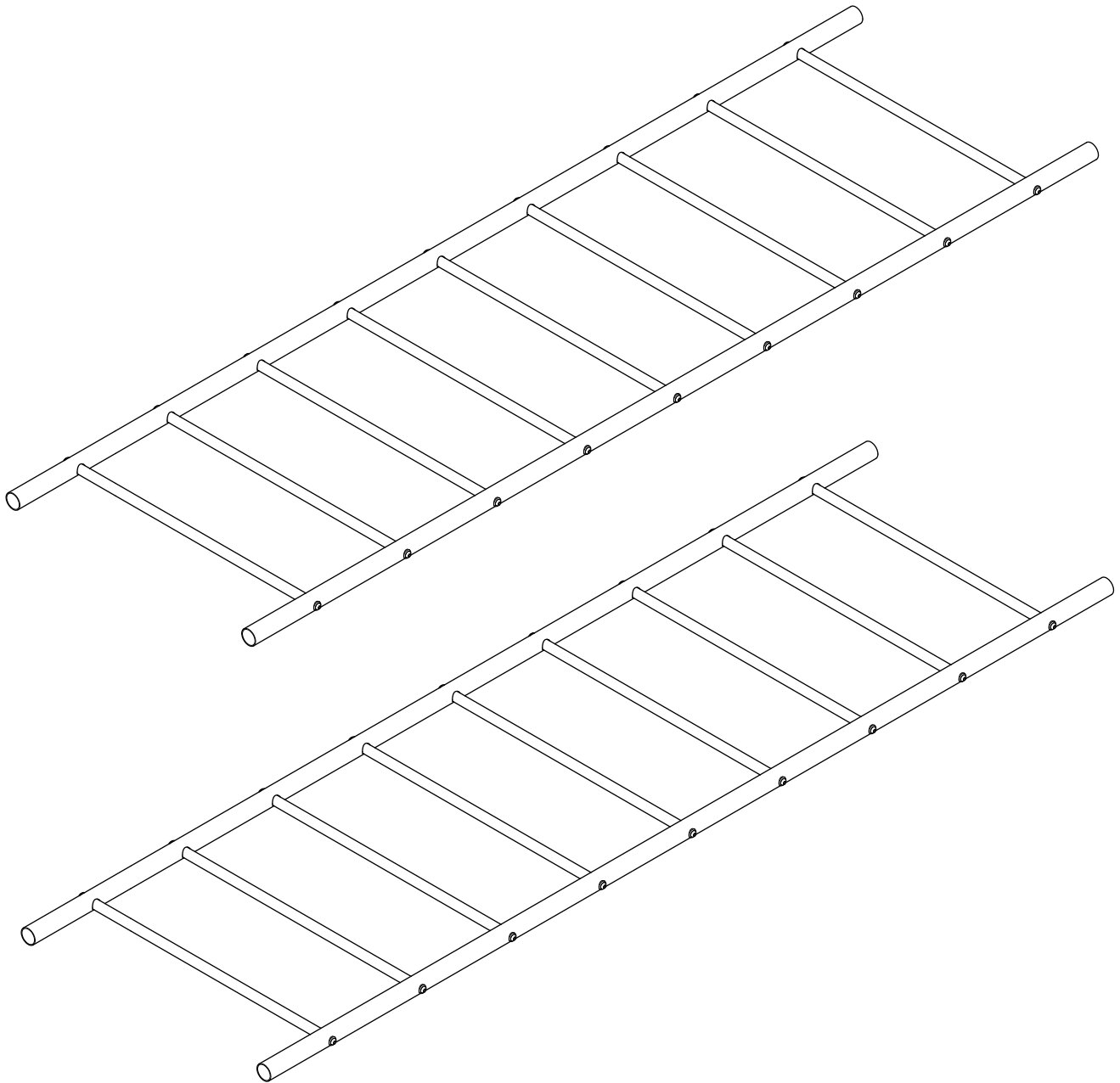

# ASSEMBLY INSTRUCTIONS - COMBAT LADDER BAR ASSEMBLY

## 7 COMBAT LADDER (x3)

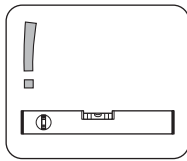
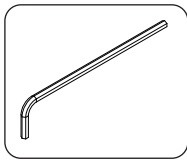

Hand tighten all bolts.  
Assemble on flat surface.

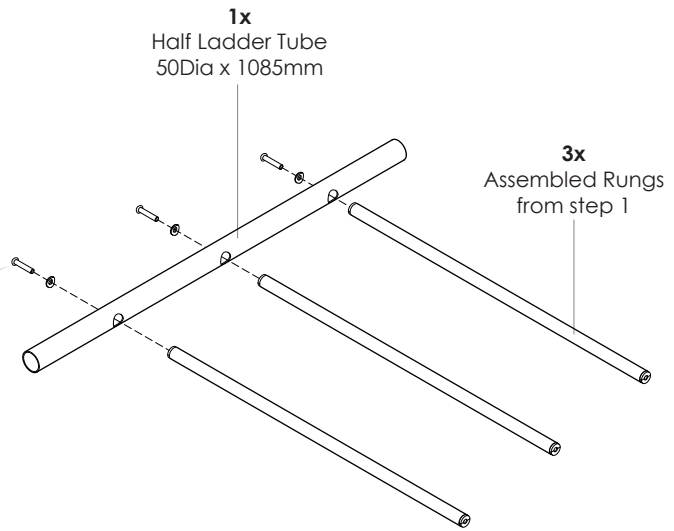
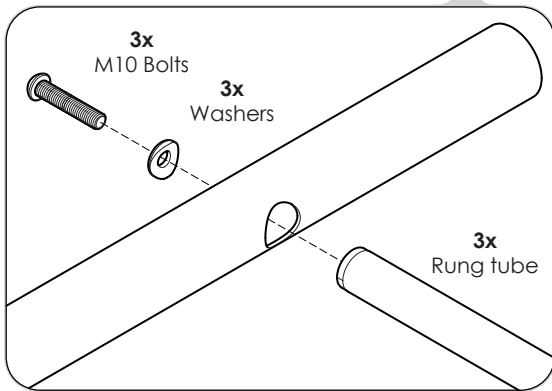

## 8 ATTACH SECOND HALF LADDER TUBE

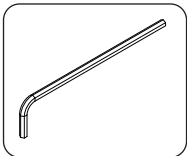

Hand tighten all bolts

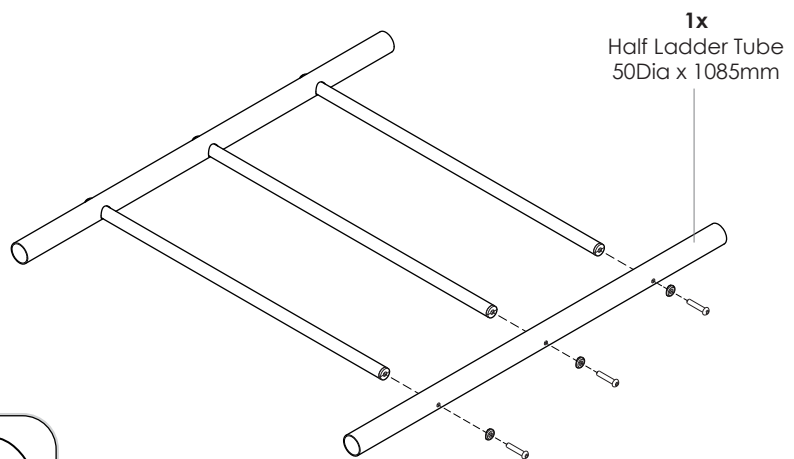
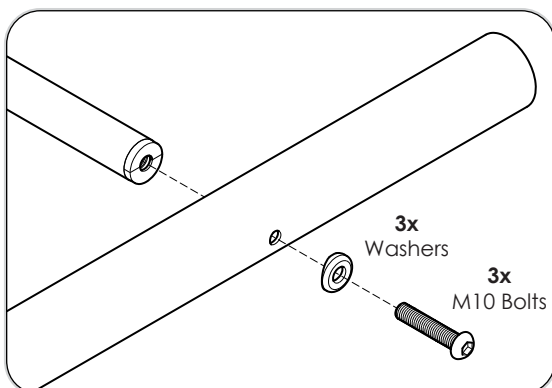

**9** FIRMLY TIGHTEN ALL GRUB SCREWS.

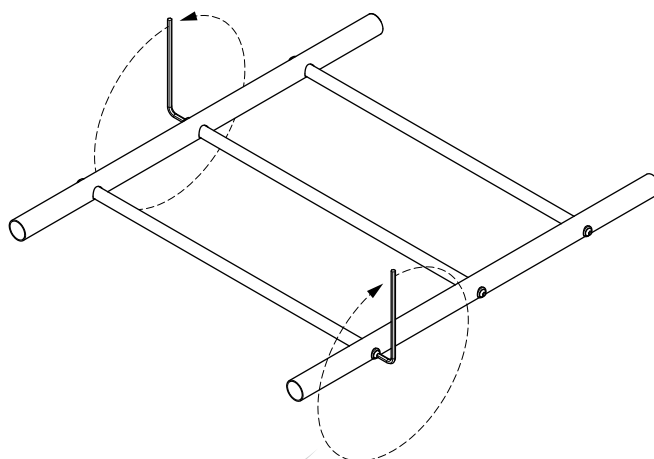
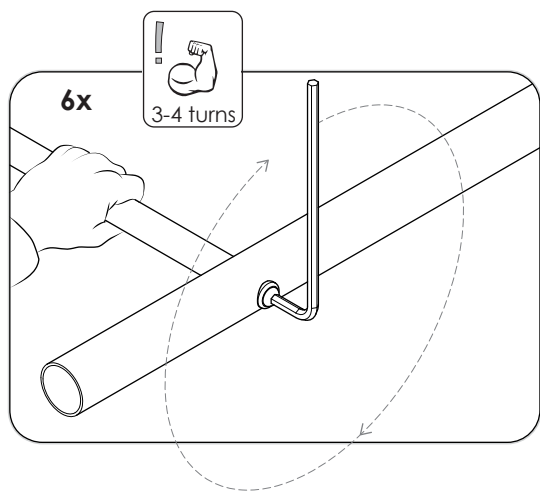
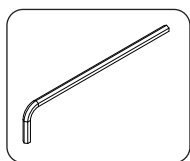

**10** REPEAT STEPS 7 - 9 FOR 2 MORE COMBAT LADDERS.

**11** COMBAT LADDER X3.

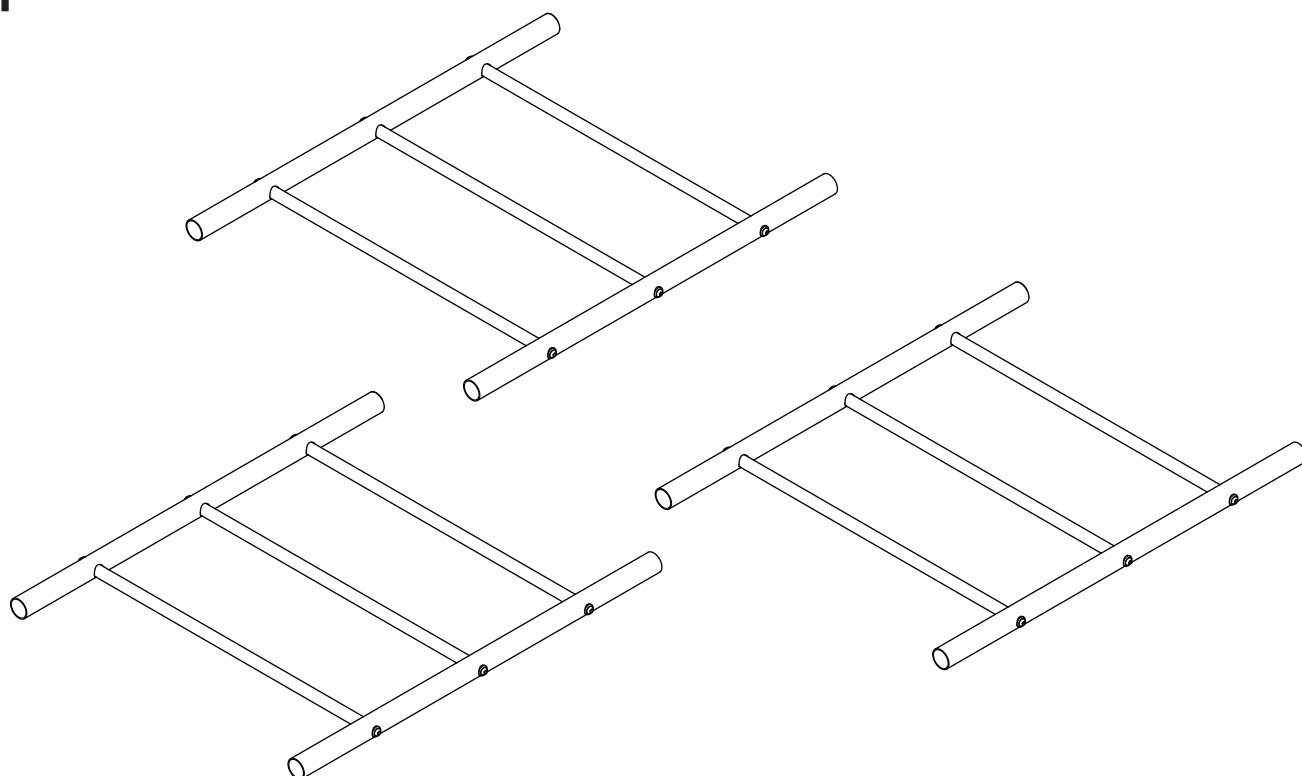

# ASSEMBLY INSTRUCTIONS - LEG ASSEMBLY

## 12 LEG ASSEMBLY x3

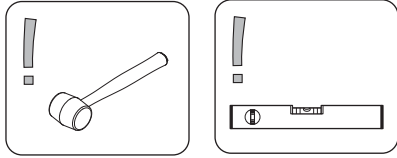

Insert plastic end caps into leg tubes.

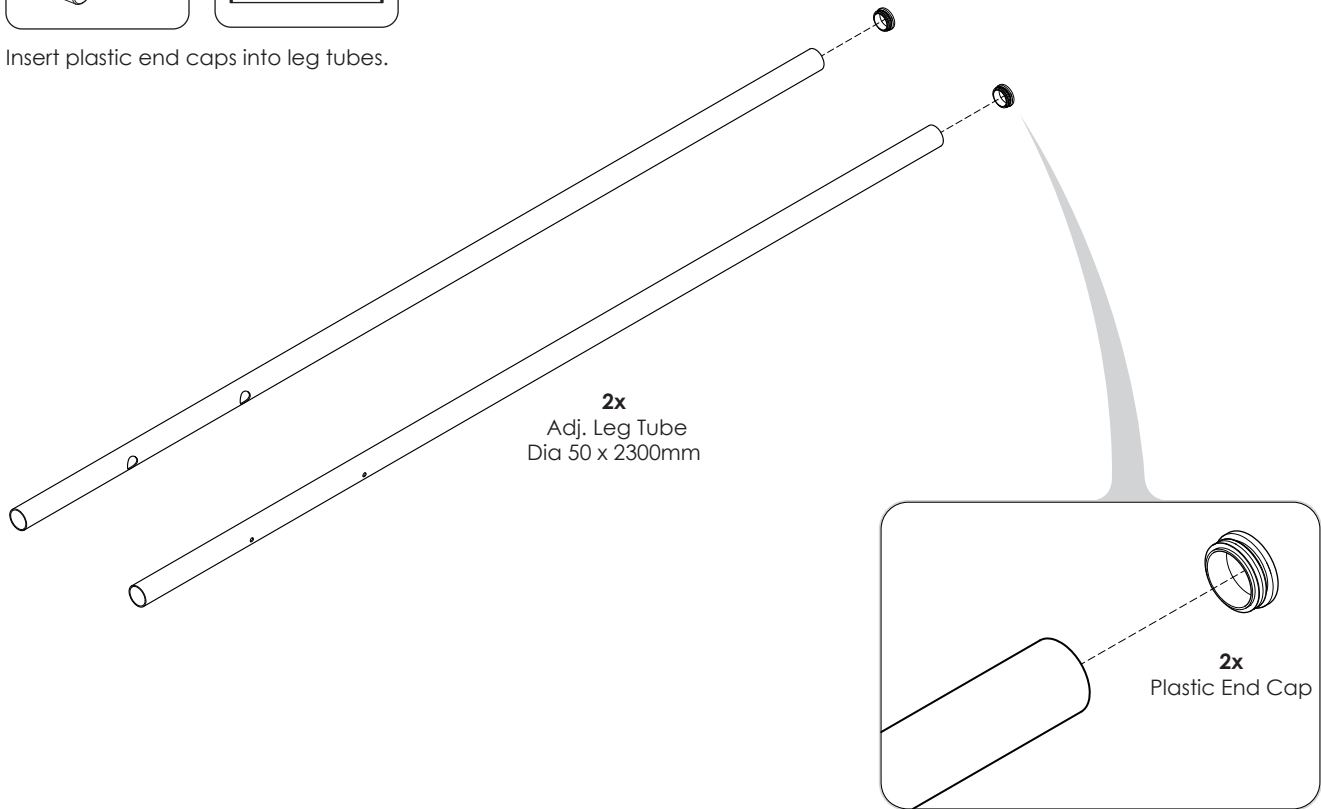

## 13 INSERT RUNGS

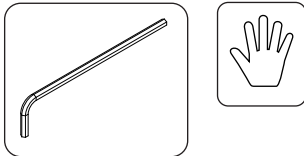

Hand tighten all bolts.

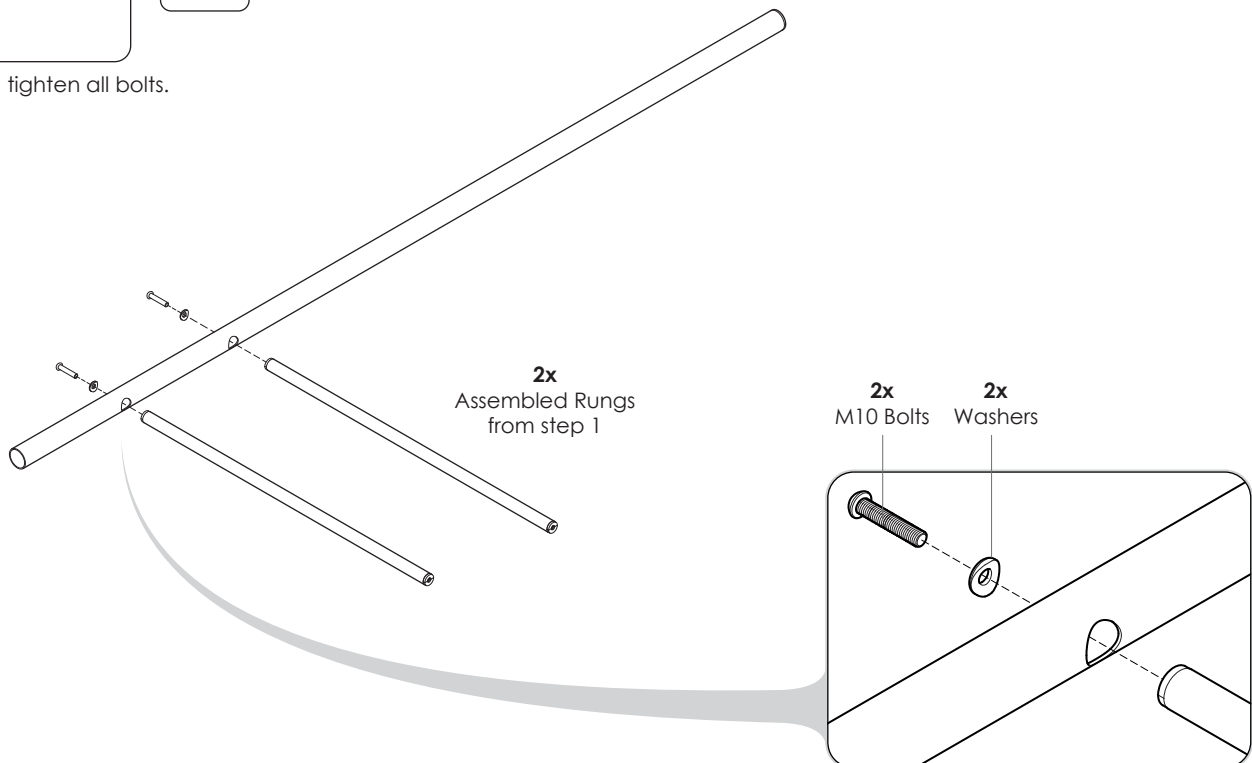



## 14 ATTACH SECOND LEG AND CARGO NET

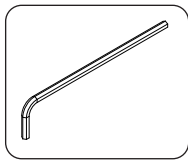

Hand tighten all bolts.



1. Slide cargo net onto second leg tube.

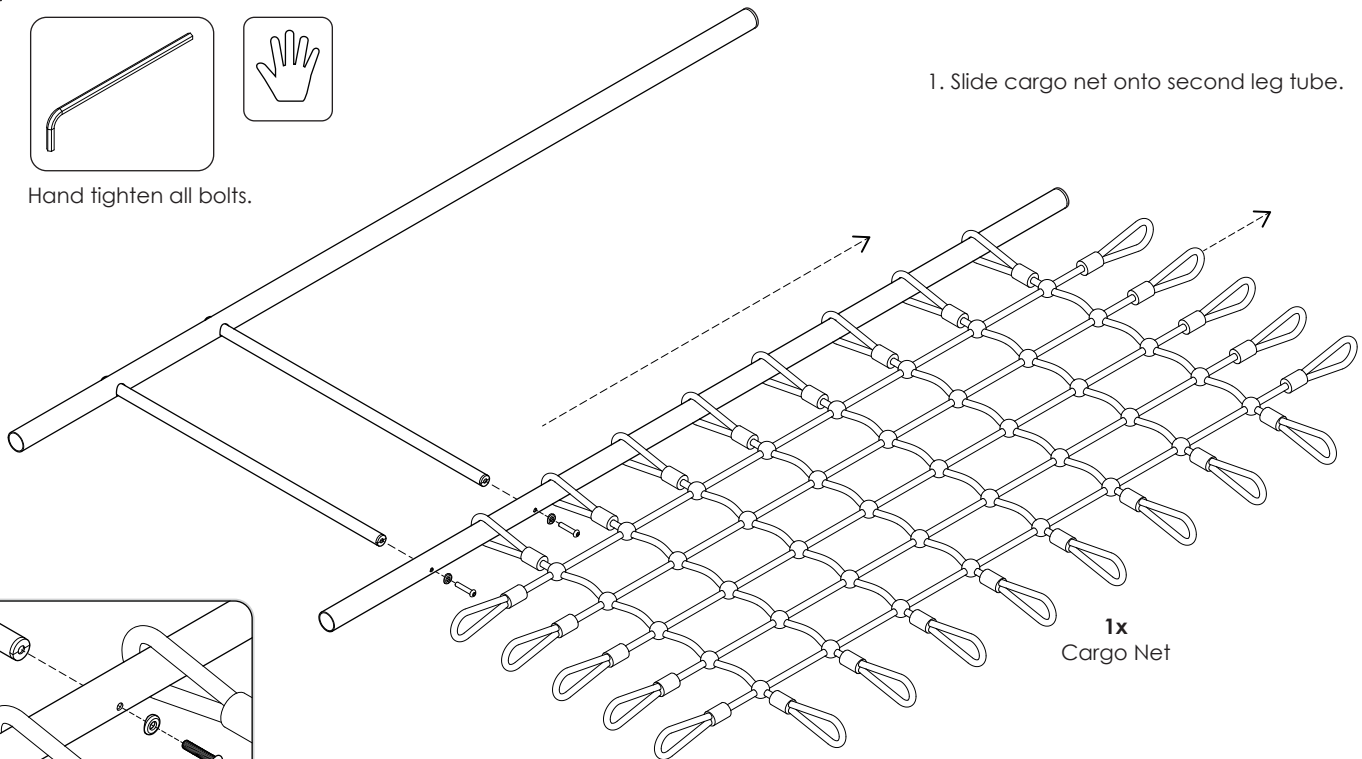

1x  
Cargo Net

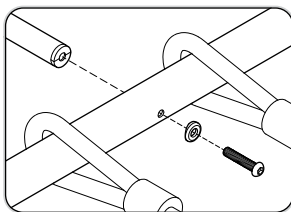

2. Ensure one hoop is between the rungs. Bolt leg to rungs.

## 15 ATTACH BASE PLATES AND 1x SHORT TEE (A) (CARGO NET SIDE)

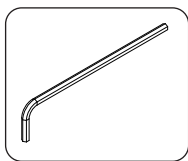

Tighten all grub screws on base plates.

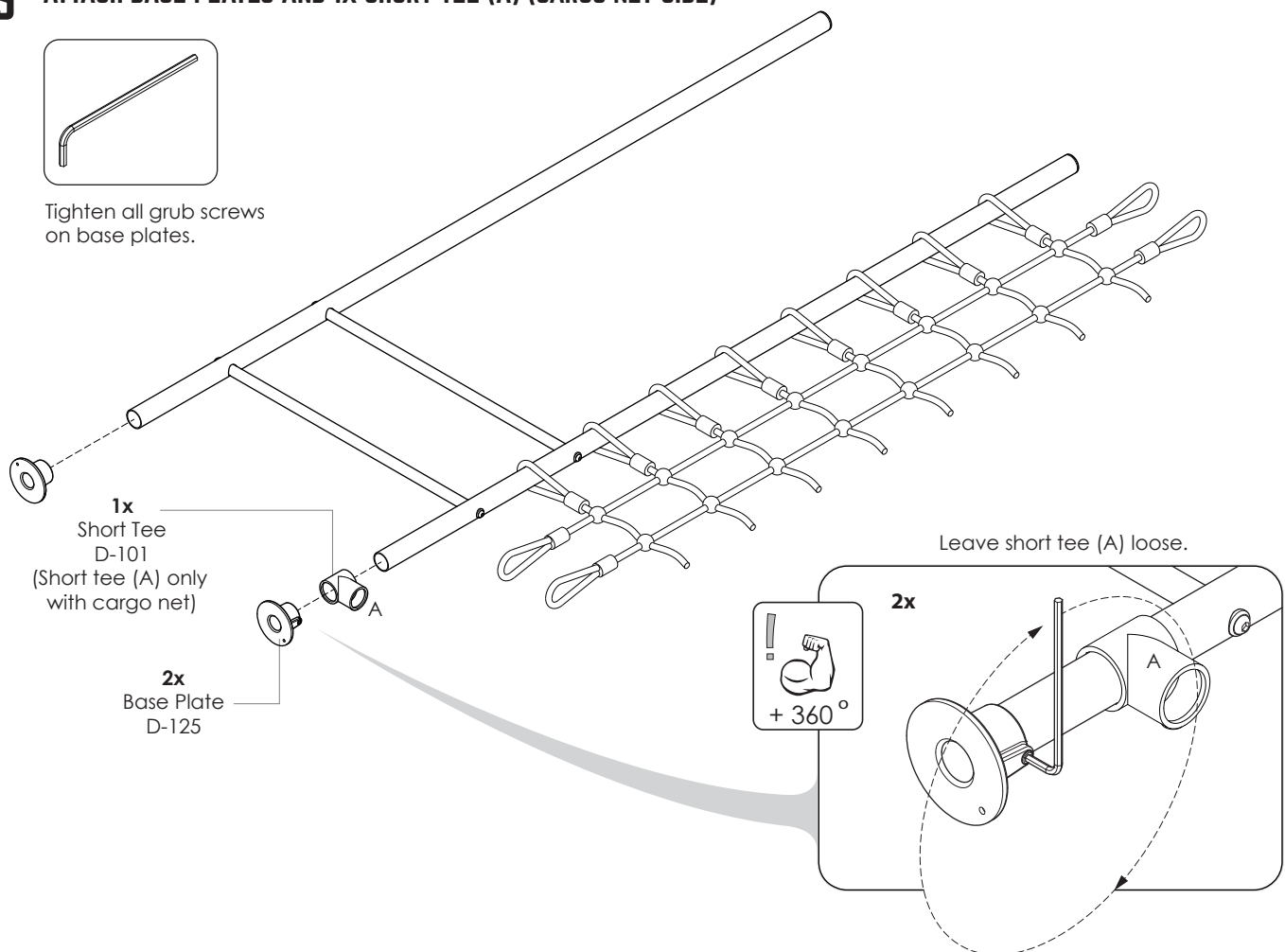

1x  
Short Tee  
D-101  
(Short tee (A) only  
with cargo net)

2x  
Base Plate  
D-125

Leave short tee (A) loose.

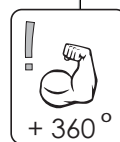

2x

+ 360°

## 16 APPLY HEIGHT STICKERS

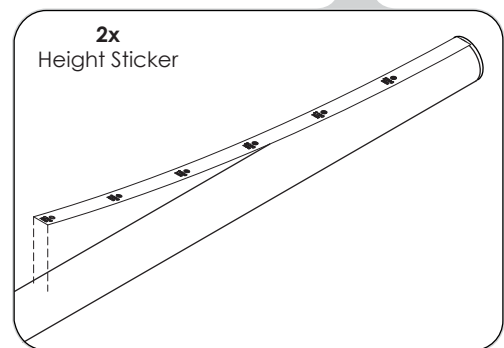
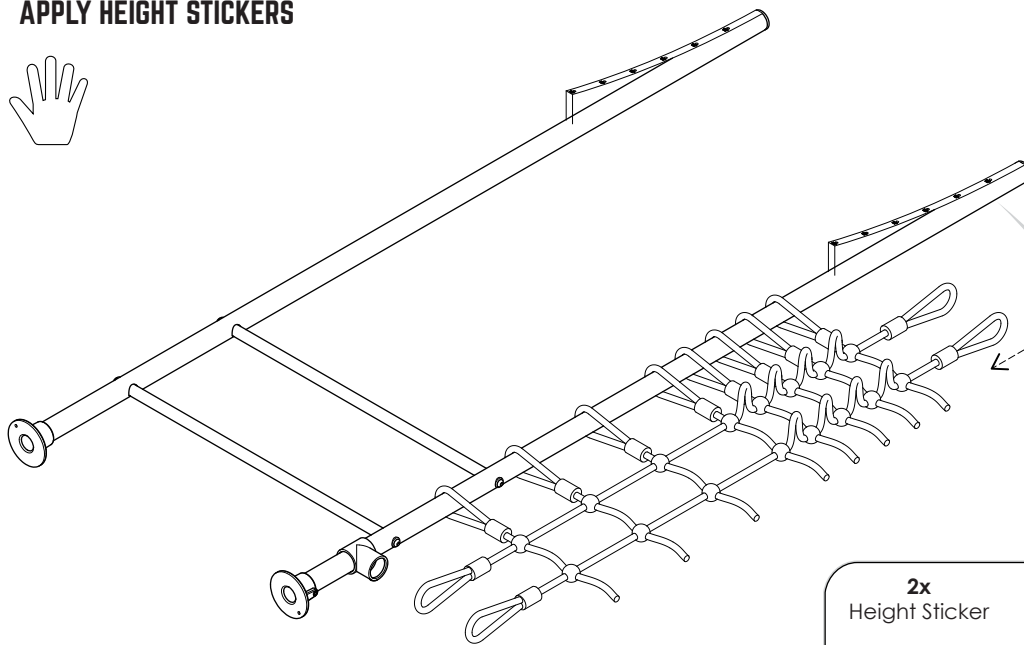

Move net downwards to allow height sticker application.

## 17 SET LADDER BAR HEIGHT.

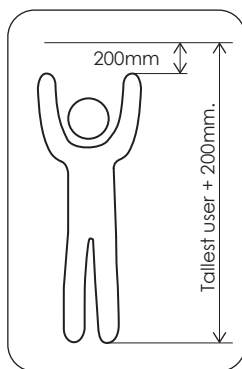

Good starting height is 100-200mm above reach.

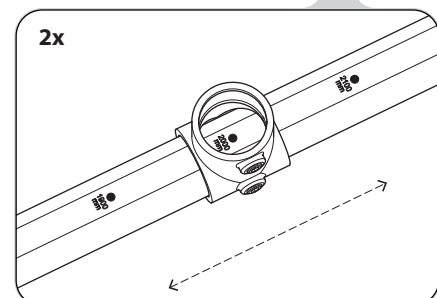
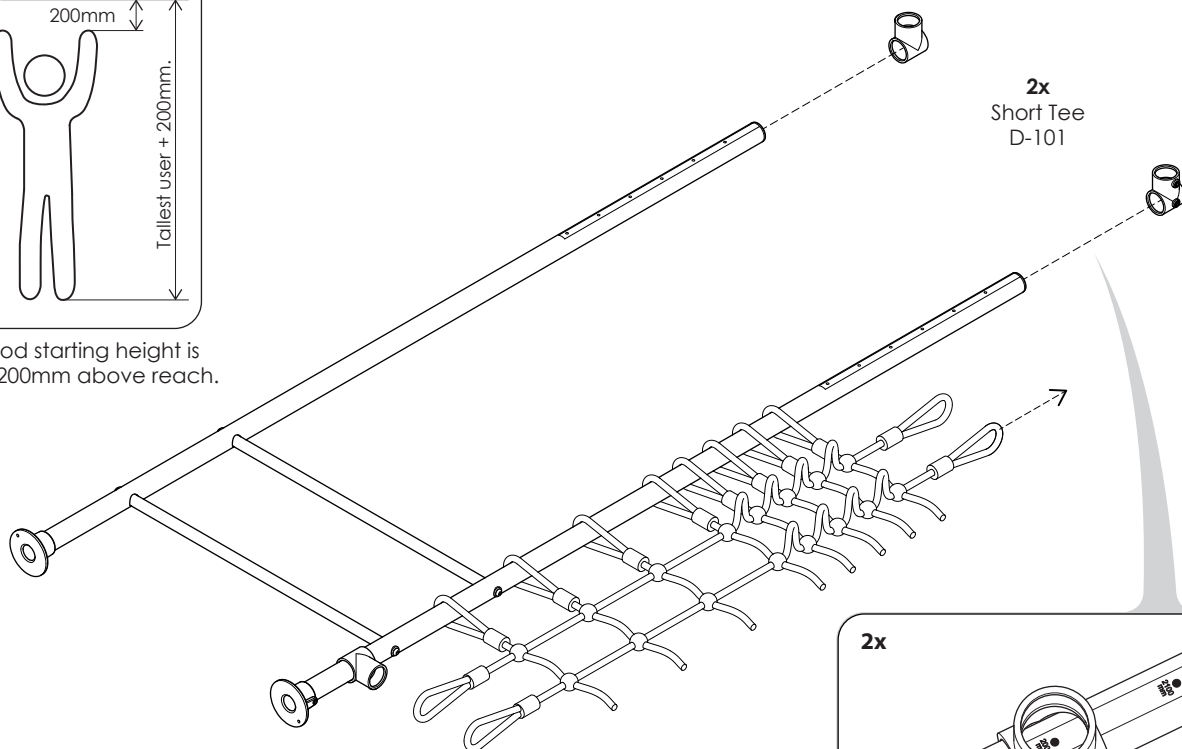

Position top short-tee at measured height.  
Push through cargo hoops if required.

## 18 FIRMLY TIGHTEN ALL GRUB SCREWS AND RUNG BOLTS.

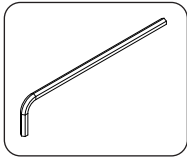

Hand tighten grub screw A. (Temporary location). Fully tighten all others.

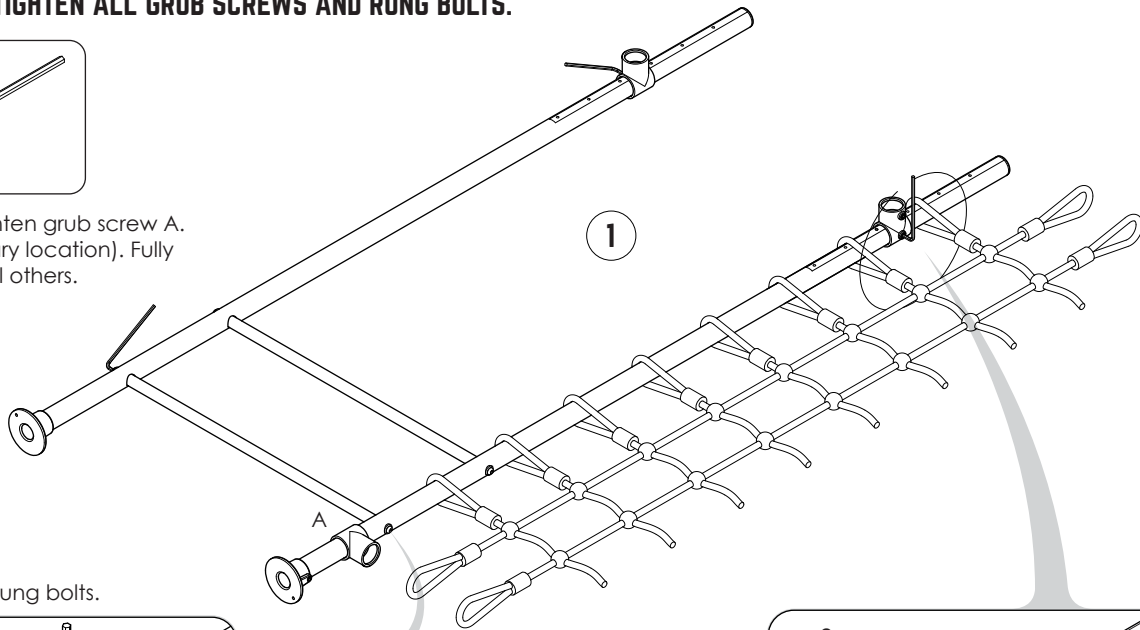

Fully Tighten rung bolts.

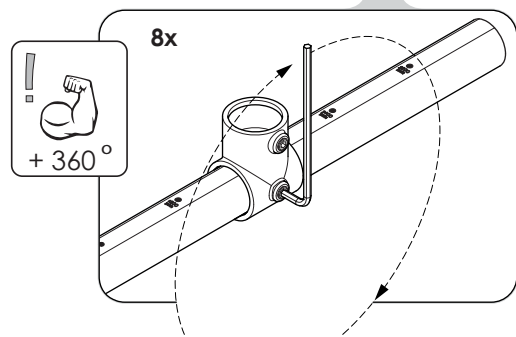
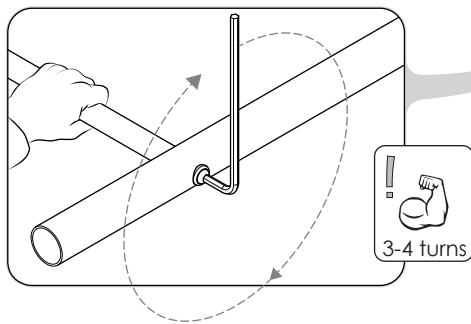

## 19 REPEAT STEPS 12-18 FOR 2x MORE LEG ASSEMBLIES. SAME PROCEDURE BUT WITHOUT CARGO NET AND ADDITIONAL SHORT TEE (A). DIFFERENT SHORT TEE ARRANGEMENT AT TOP- (SEE STEP 20 FOR FINAL RESULT)

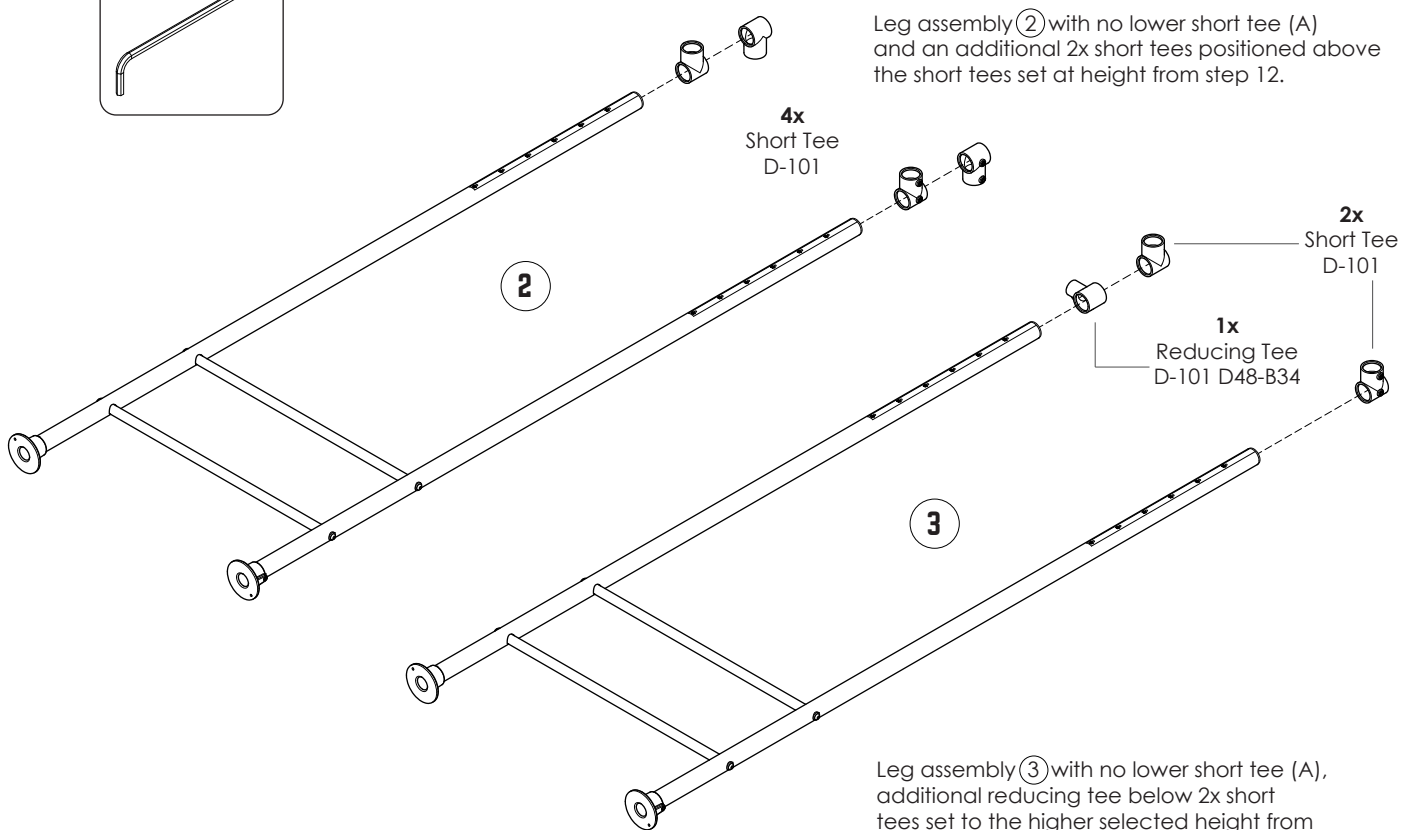
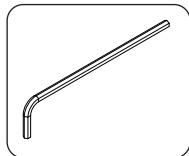

Leg assembly ② with no lower short tee (A) and an additional 2x short tees positioned above the short tees set at height from step 12.

Leg assembly ③ with no lower short tee (A), additional reducing tee below 2x short tees set to the higher selected height from leg assembly 2.

## 20 LEG ASSEMBLY X 3.

Standing up with top tees facing each other.  
Check all grub screws are fully tightened  
except on fitting A (hand tight only).

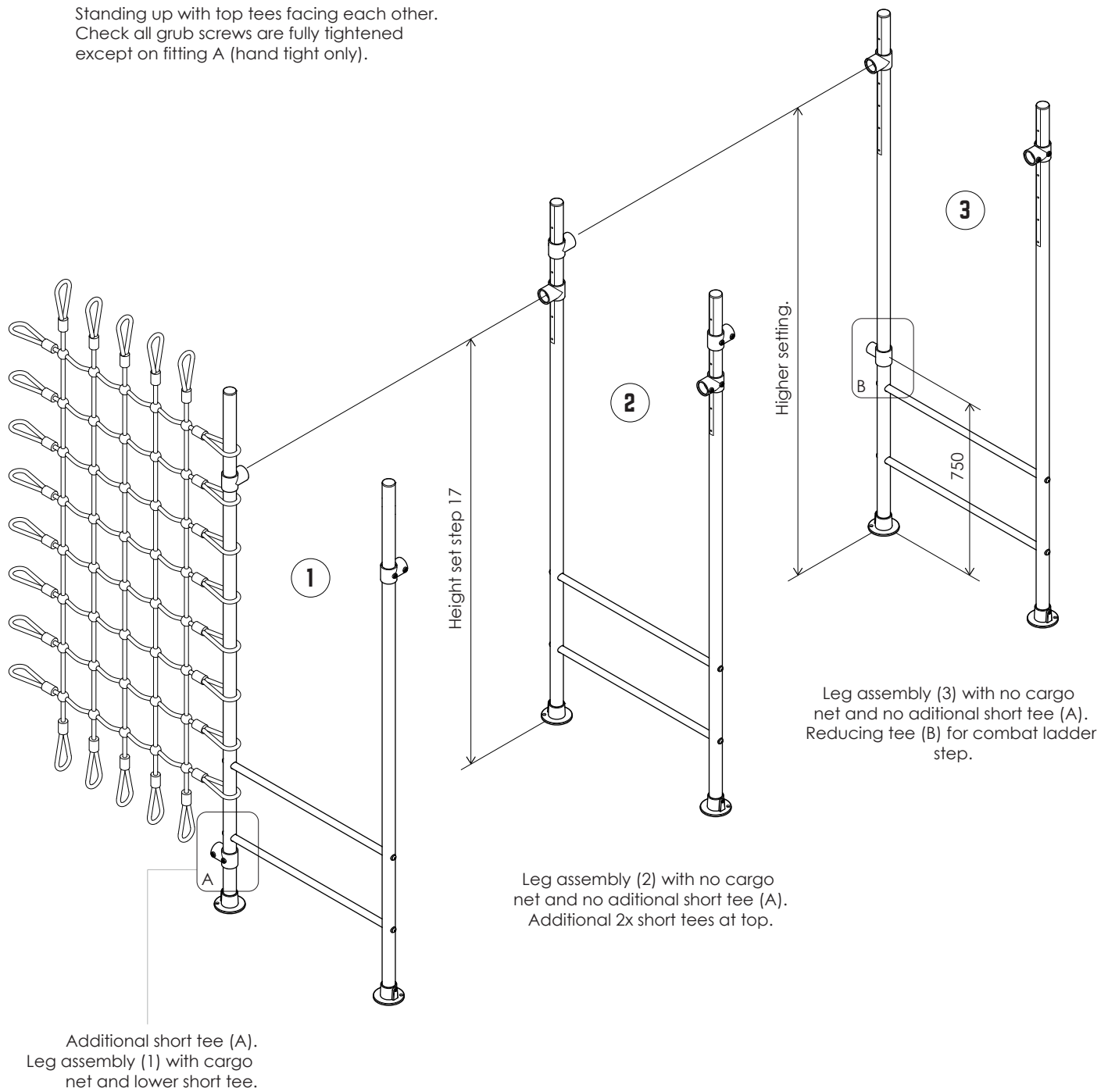

## 21 CHECK ALL FITTING GRUB SCREWS AND RUNG BOLTS ARE FULLY TIGHTENED

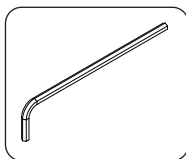

Firmly tighten all grub screws and bolts,  
Leave short tee A loose.

# ASSEMBLY INSTRUCTIONS - TWIRLY WHIRLY BAR ASSEMBLY

## 22 ASSEMBLE VERTICAL TWIRLY TUBE

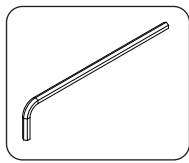

Tighten all grub screws.

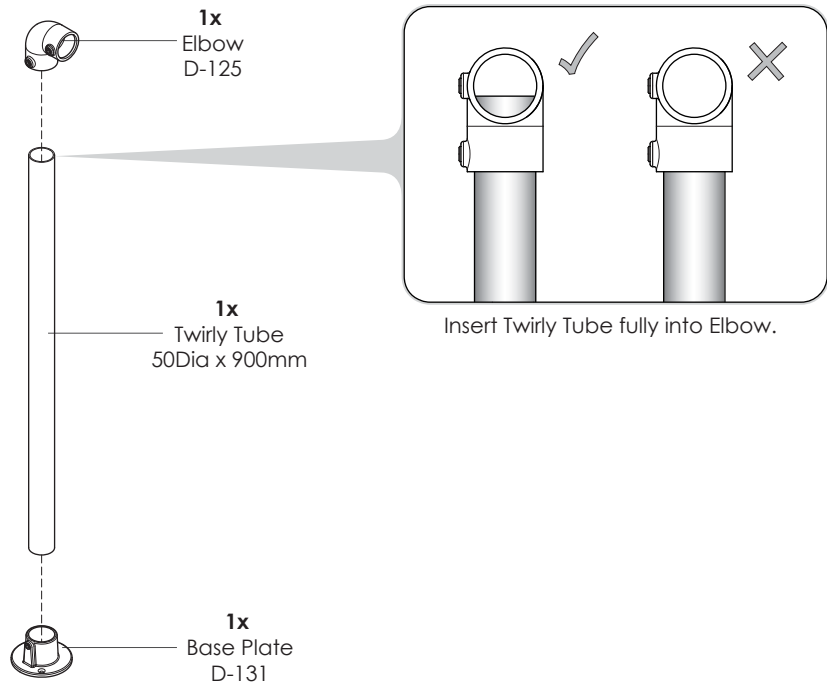

## 23 ATTACH HORIZONTAL TWIRLY TUBE

Fully insert twirly tube then firmly tighten all grub screws.

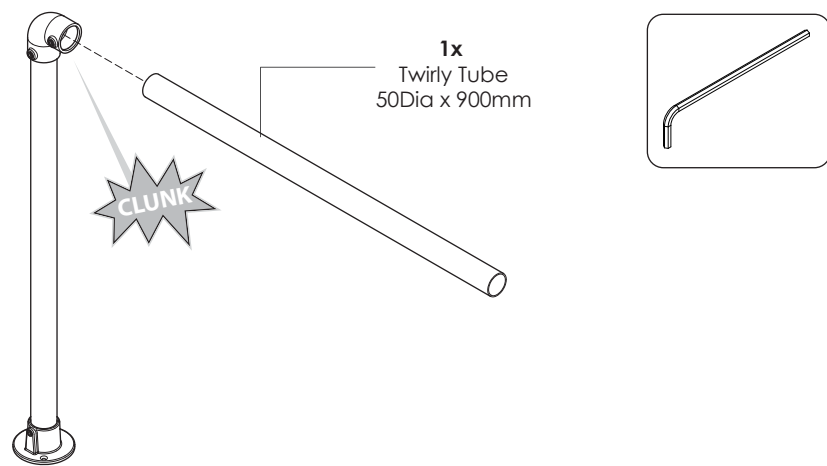
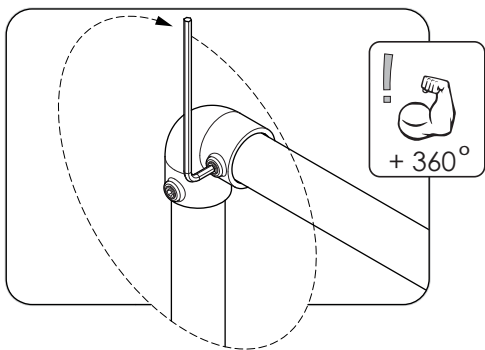

## 24 REPEAT STEPS 22 - 23 FOR 3 MORE TWIRLY WHIRLY BARS.

## 25 TWIRLY WHIRLY BAR x4

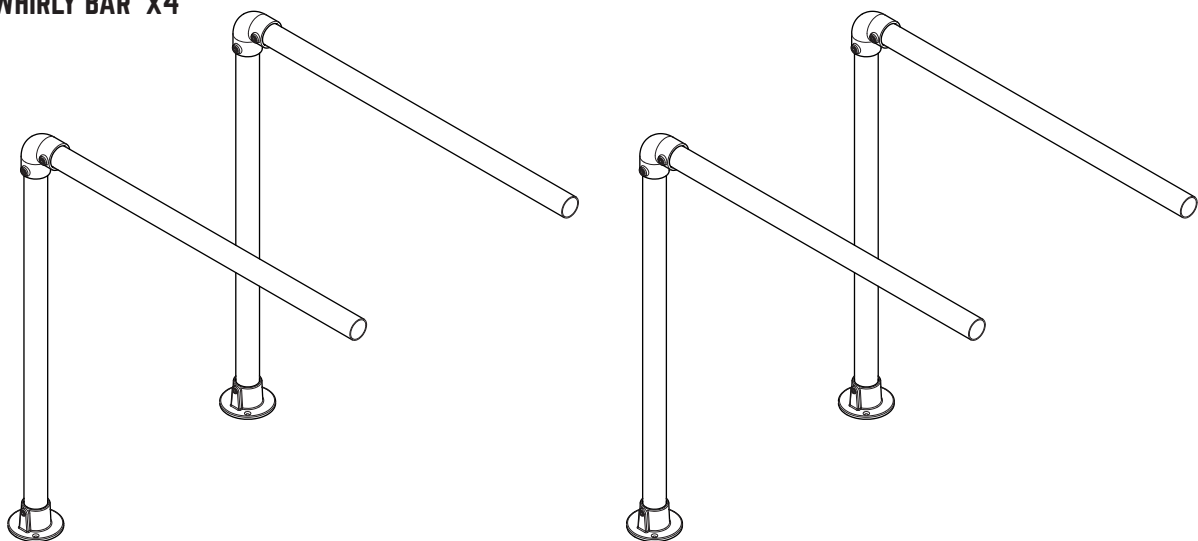

# ASSEMBLY INSTRUCTIONS - MAIN MONKEY BAR ASSEMBLY

## 26 FLIP LEGS 1 & 2 OVER

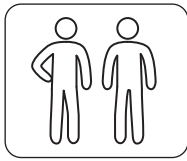

For the following step the legs should be flipped over & attached one at a time.

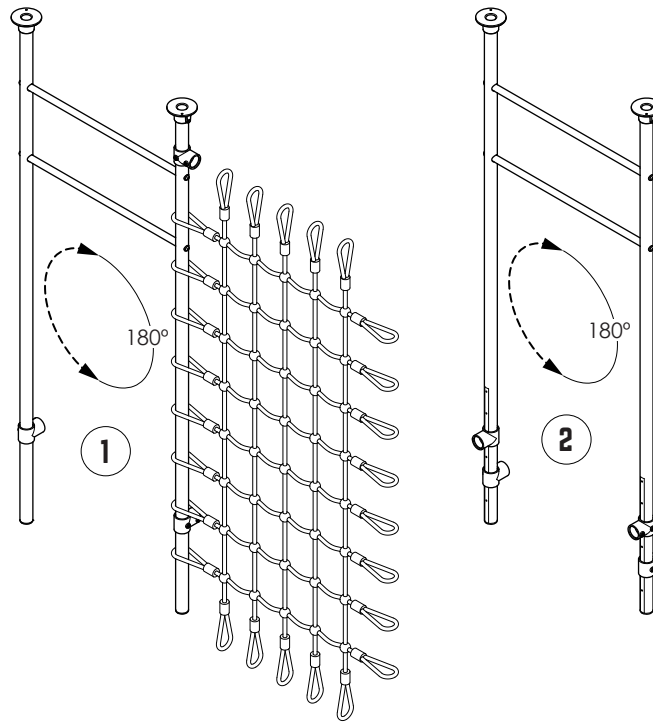

## 27 ATTACH 2X LEGS TO LADDER

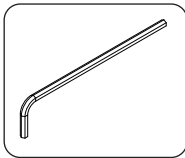

1. Attach first set of legs ① - tighten all grub screws.
2. Attach second set of legs ② - tighten all grub screws.

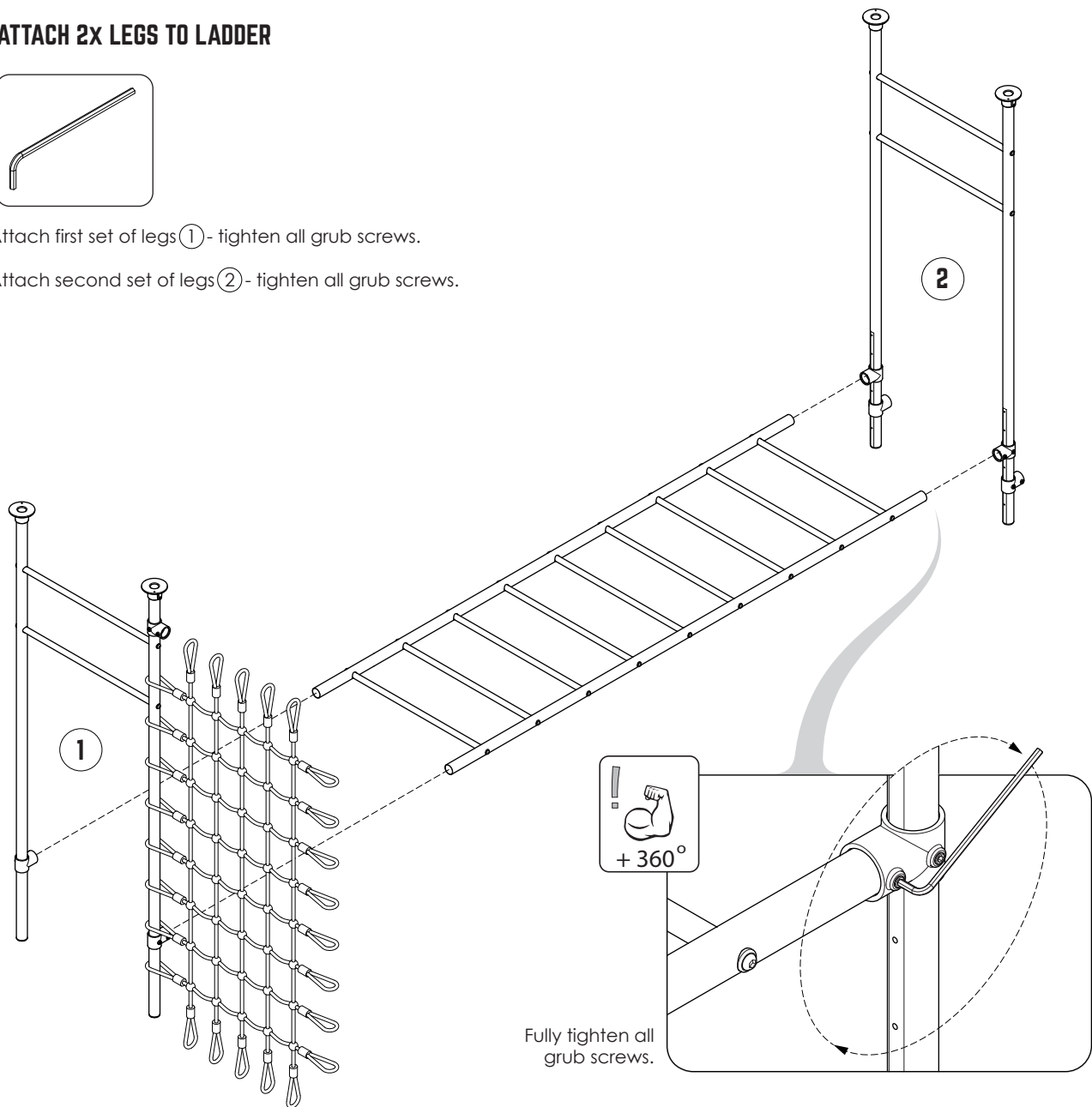

## 28 FLIP ASSEMBLY OVER

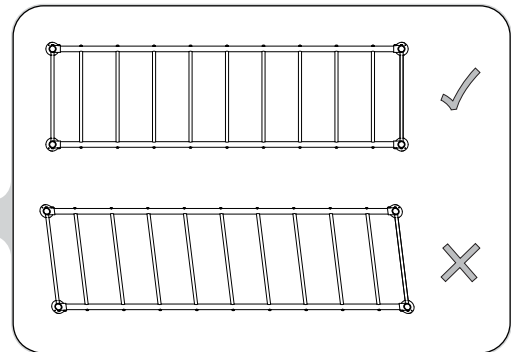
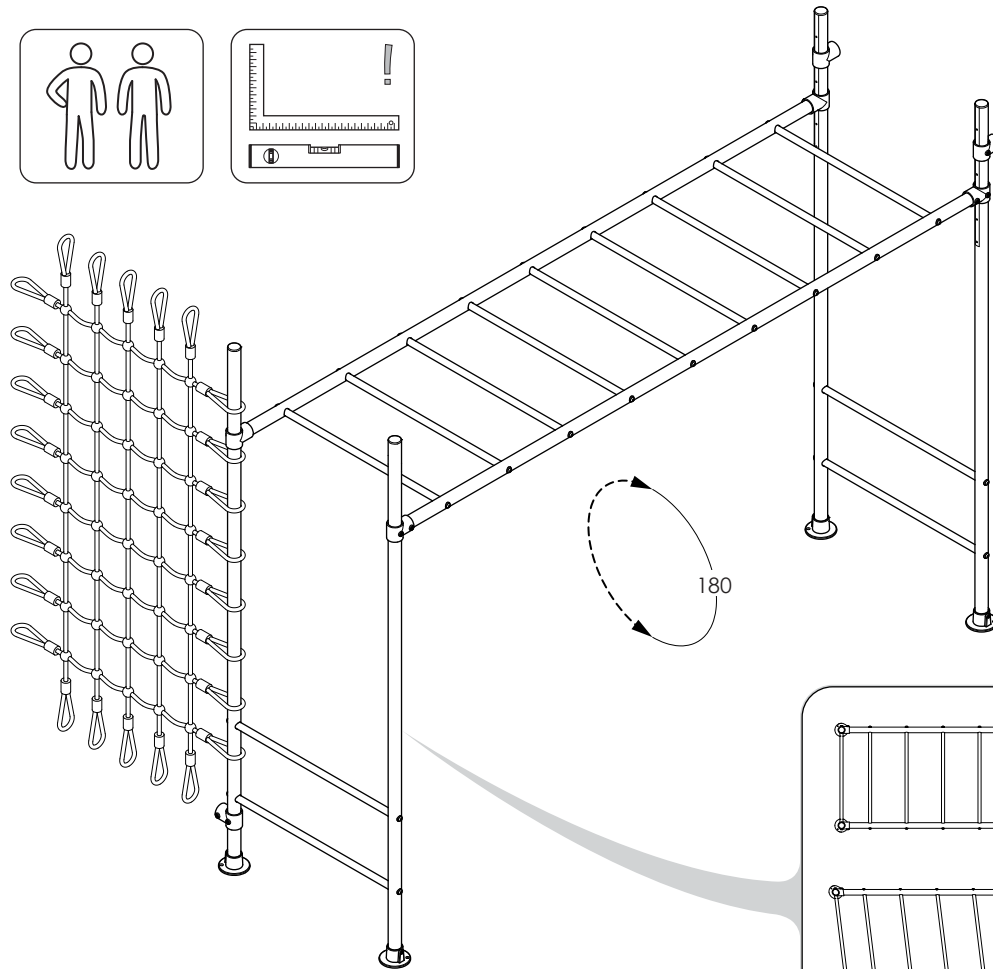
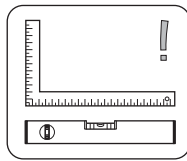
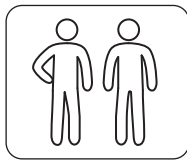

**CRITICAL : ENSURE YOUR FRAME IS 100% SQUARE AND LEVEL (AS PER PAGE 6) BEFORE MOVING ONTO THE REST OF THE ASSEMBLY**

## 29 SECURE TO GROUND

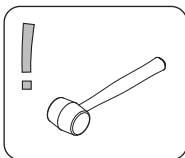

Select suitable location.  
Hammer in pegs x4.

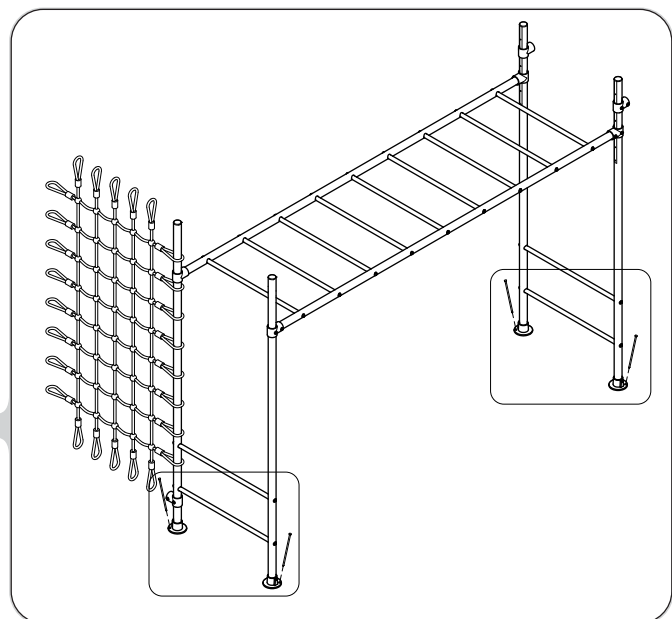
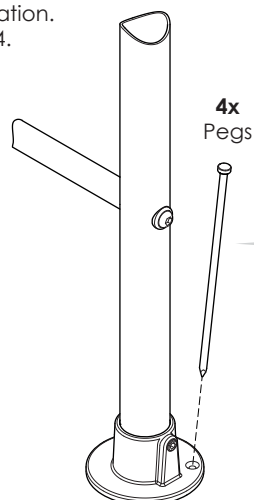

### 30 ATTACH 1x LEGS TO LADDER

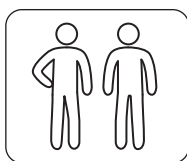
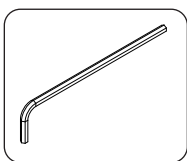

1. Flip Legs ③ over from step 20.
2. Attach second ladder to short tees.
3. Fully tighten all grub screws.

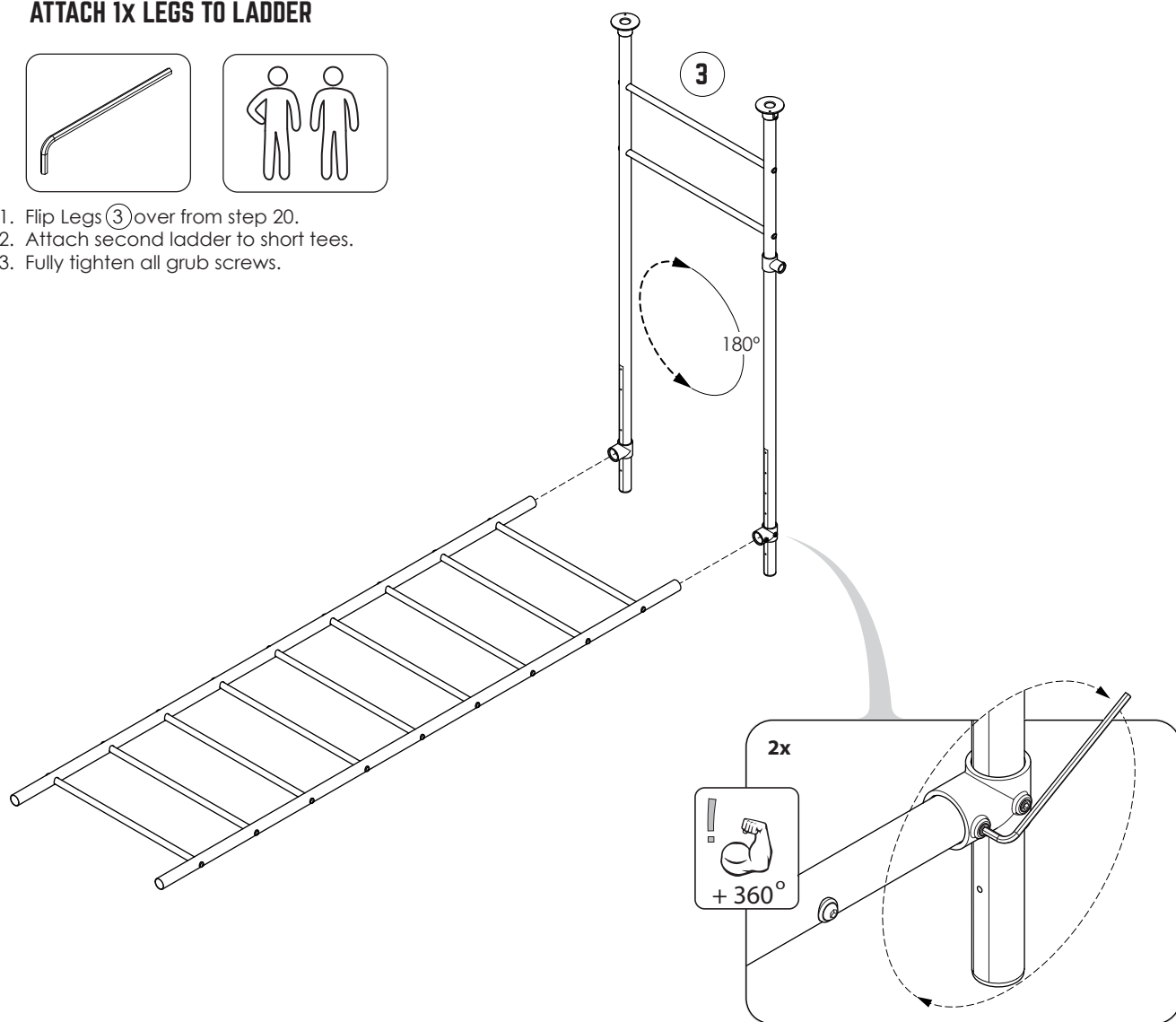

### 31 FLIP ASSEMBLY OVER

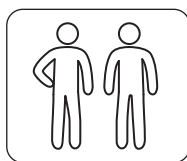

With two people flip assembly over to the upright position.

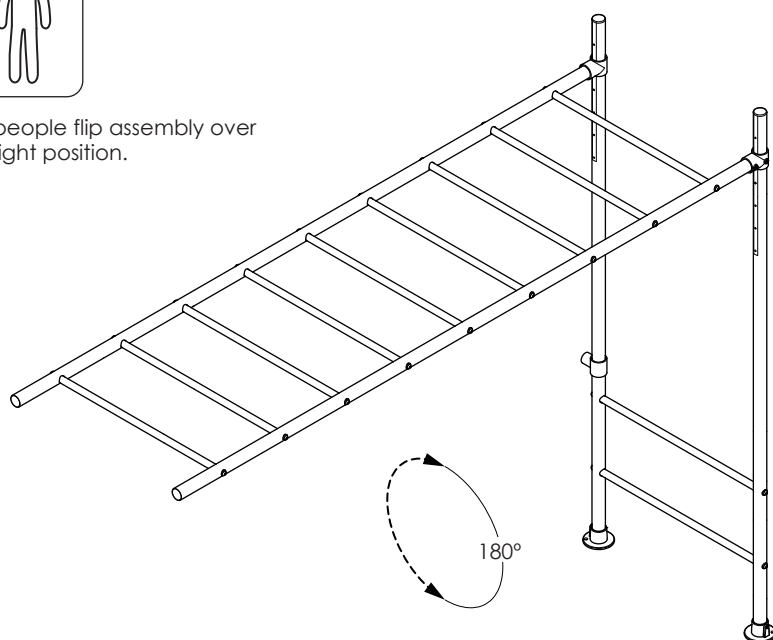



### 32 ATTACH SECOND MAIN MONKEY BAR ASSEMBLY

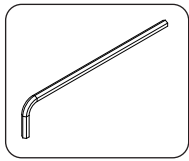

Attach the new assembly to the existing pegged down main monkey frame.

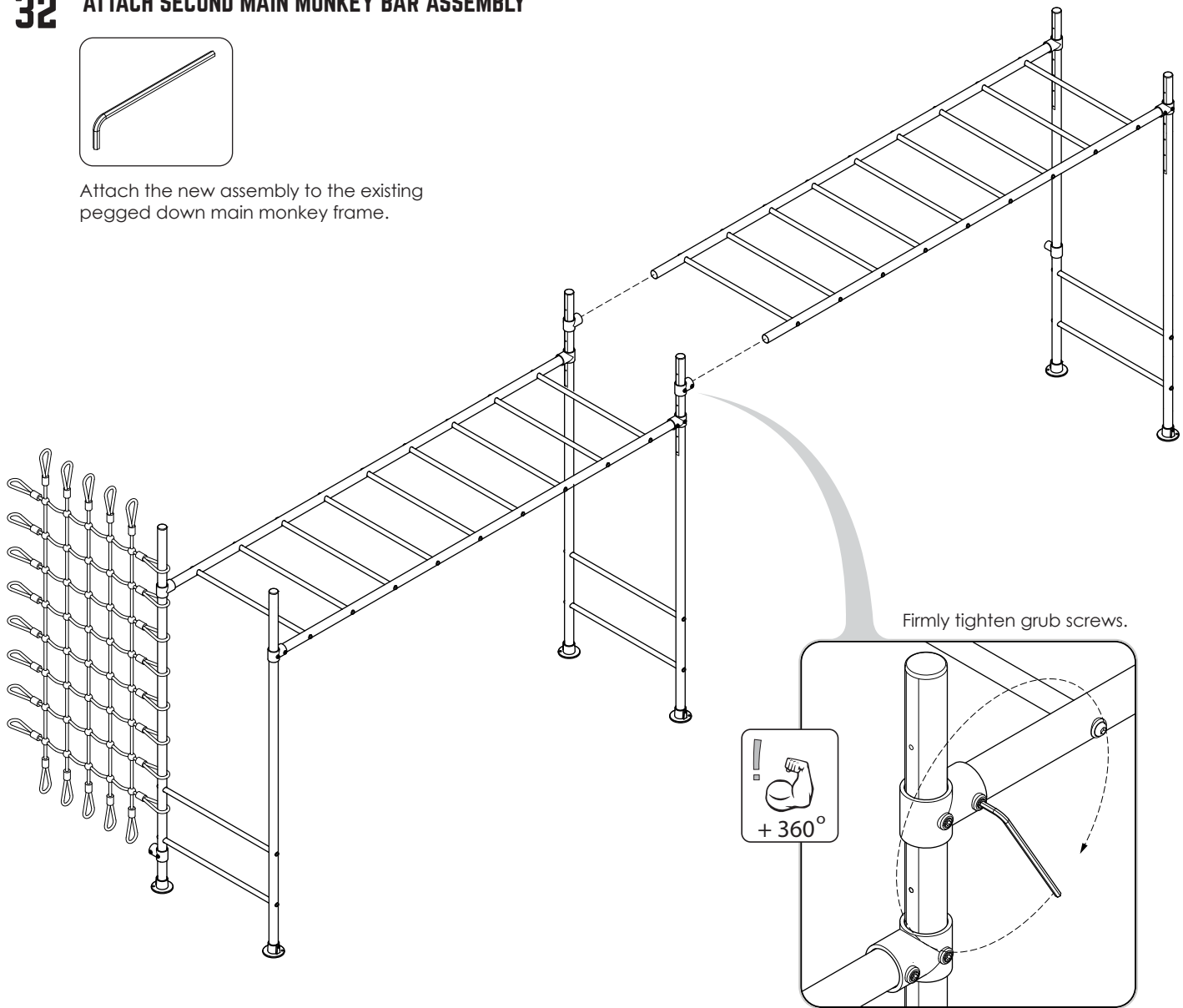

### 33 SECURE TO GROUND

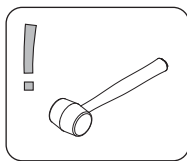
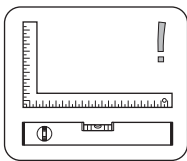

1. Check level and square.
2. Hammer in pegs x2.

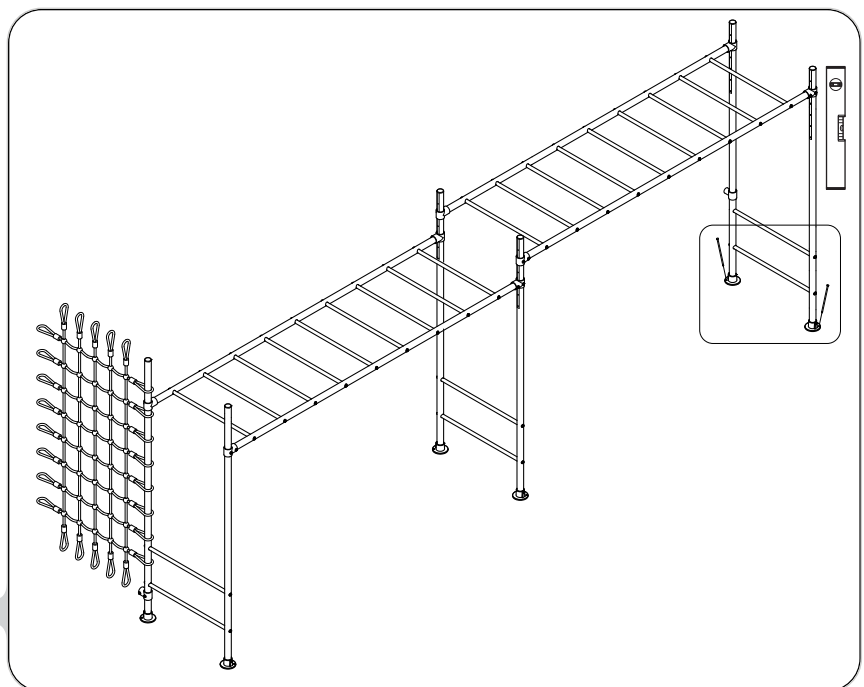
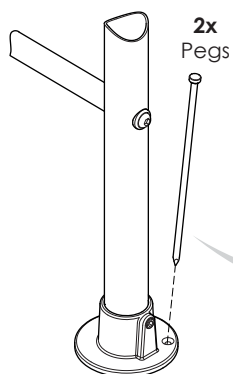

# ASSEMBLY INSTRUCTIONS - SWING BAR ASSEMBLY

## 34 DOUBLE SWING BAR ASSEMBLY X3.

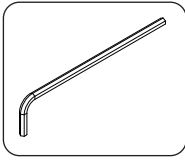

Slide on all fittings. Leave short tees and swing hooks hand tight only for assembly adjustment later, see below for spacing.

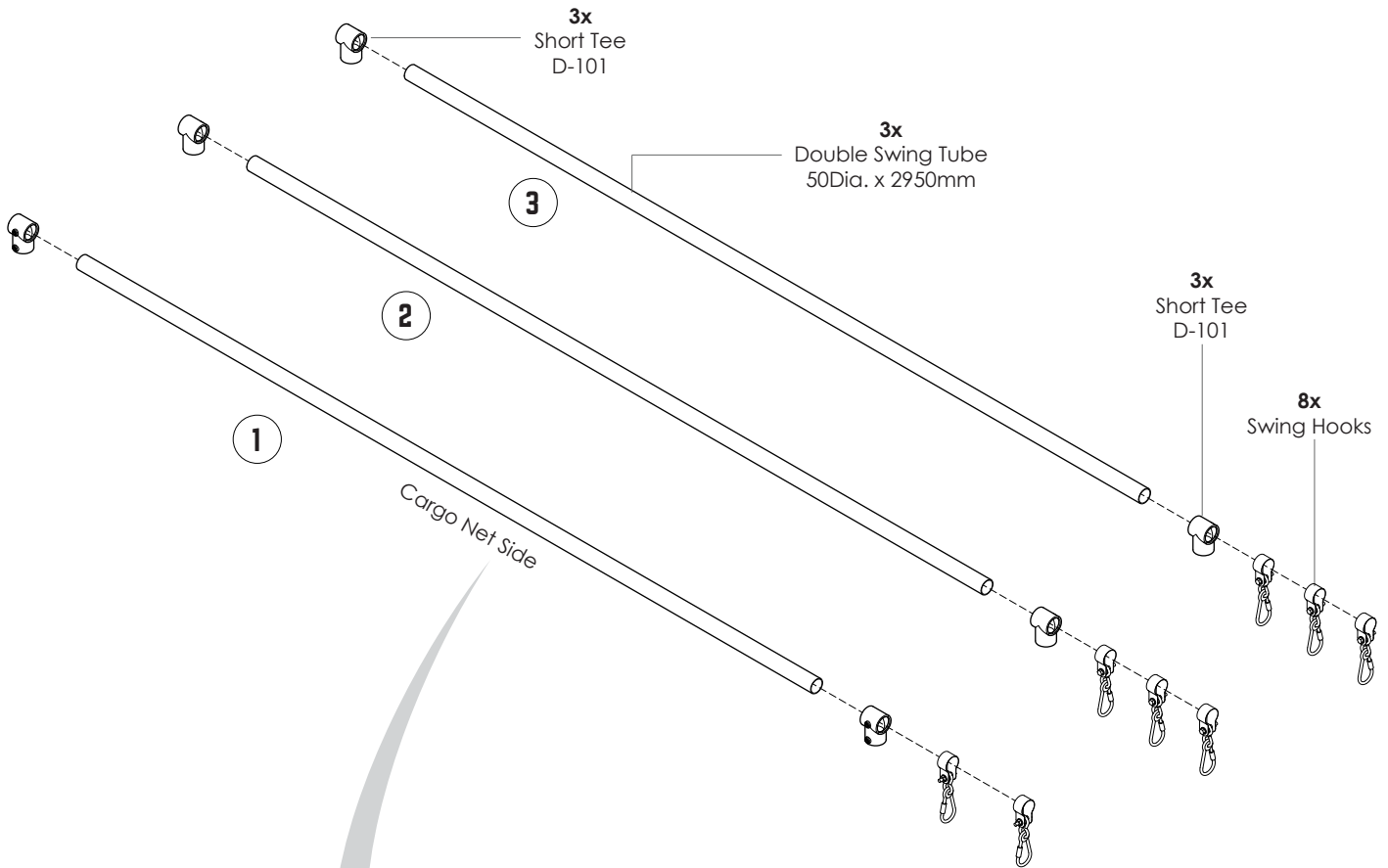

### 3X DOUBLE SWING BARS ASSEMBLED

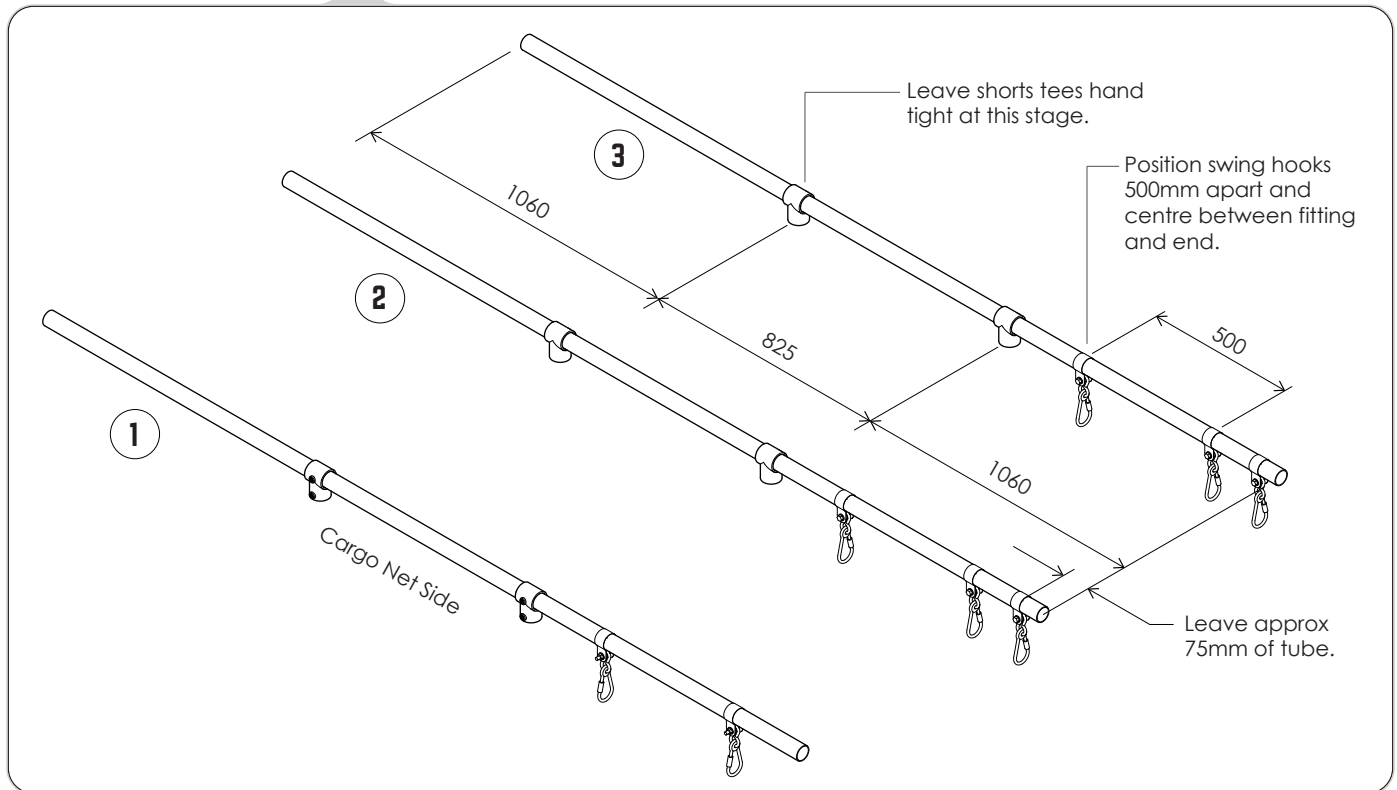

## 35 ATTACH CARGO NET SWING BAR ASSEMBLY

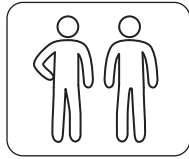
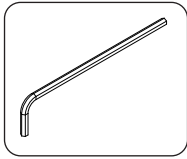

Attach the short tees (on the double swing bar 1) to the main monkey bar ladder legs. The cargo net side swing bar will need to be threaded through the top cargo net hoops before attaching. Fully tighten all grub screws.

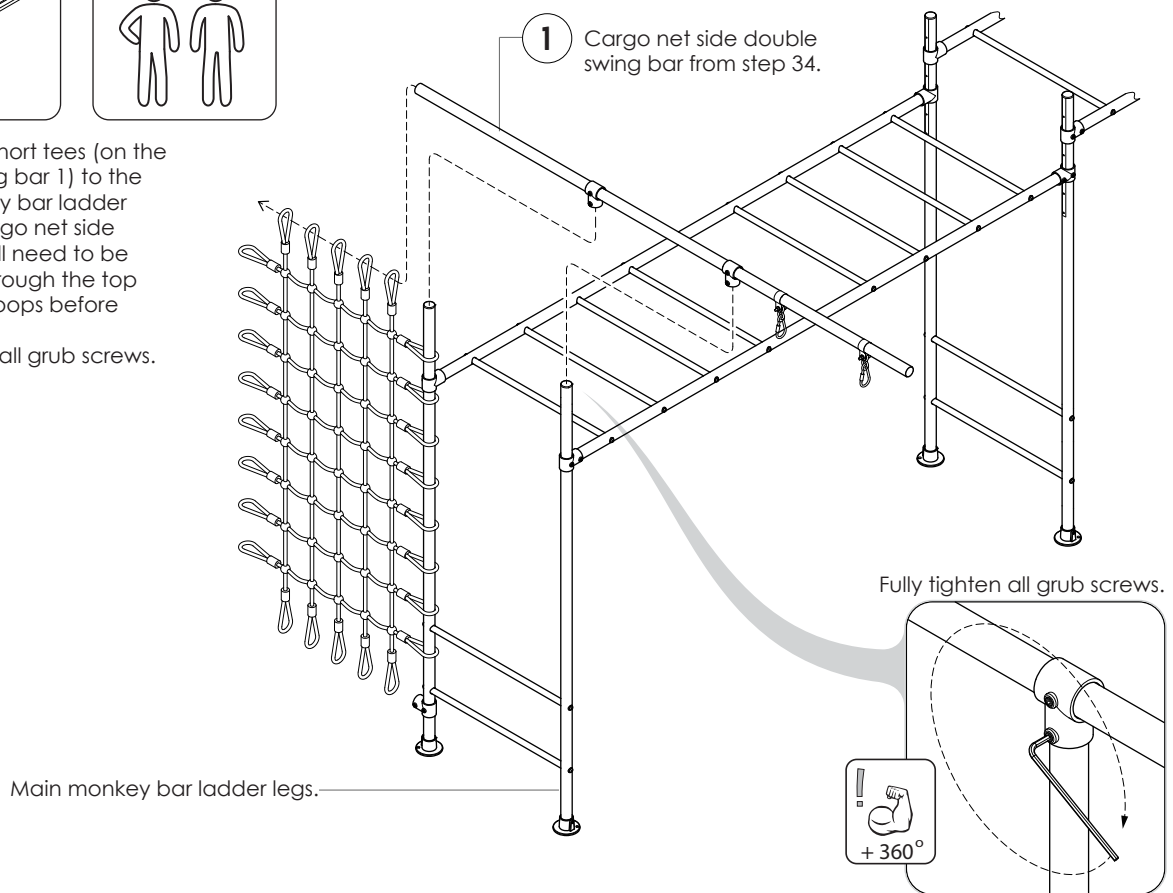

## 36 ATTACH CARGO NET SWING LEG

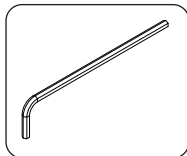

1. Feed the leg tube through the cargo net hoops, short tees and long short tee.
2. Ensure the leg tube to adj. leg tubes are 1040mm apart top and bottom.
3. Tighten grub screw on base plate & leave all others hand tight for step 37.

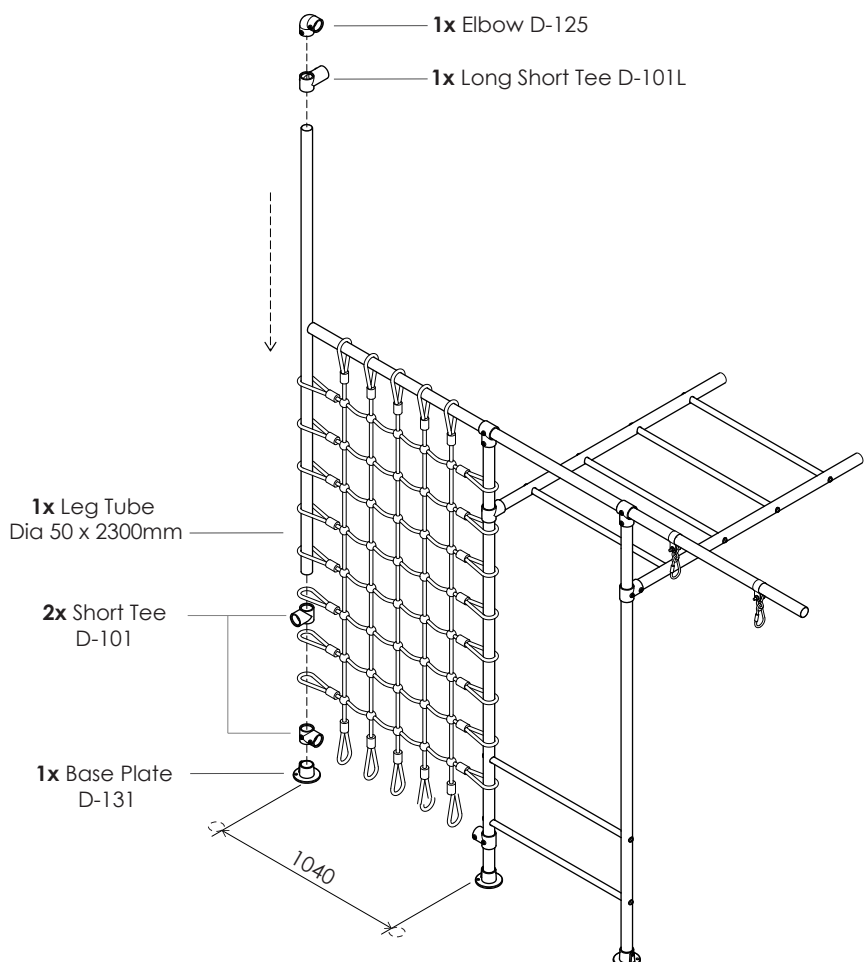

## 37 ATTACH CARGO TUBE

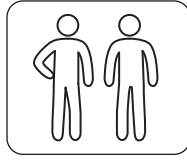
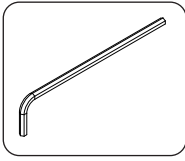

1. Ensure the cargo net gap is 1040mm apart between legs. You may need to loosen top grub screws D & E to slide the swing bar along. Retighten before continuing.
2. Check grub screws on A, B & C are loose.
3. Slide cargo bar through the bottom hoops and insert into short tee (B).
4. Pull swing leg outwards and slot other end of cargo bar into short tee (A).
4. Get second person to stand on cargo tube to make cargo net taught and level.
5. Fully engage all tubes & tighten all grub screws at cargo net end.

1x Cargo Tube  
50Dia x 1040mm

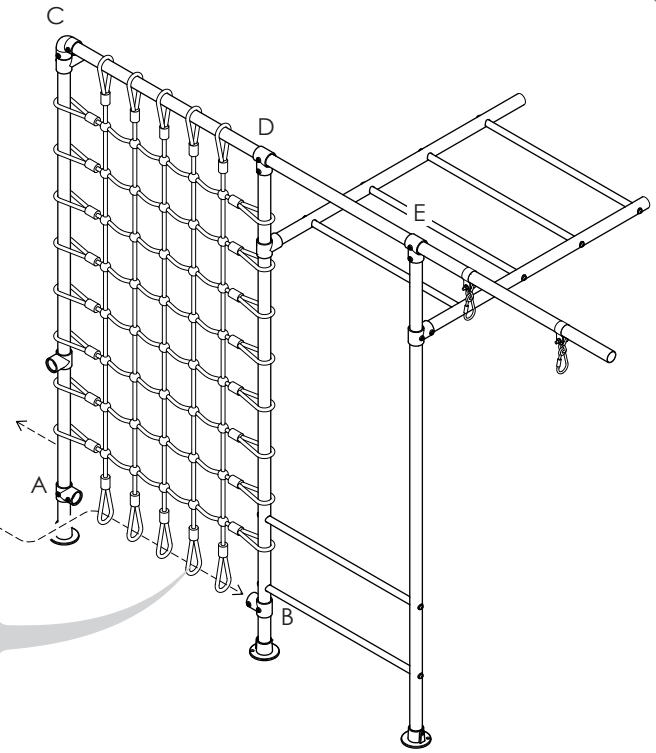
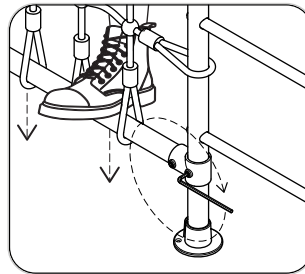

## 38 ATTACH 2X SWING BAR ASSEMBLIES

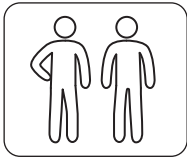
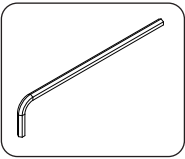

Attach the short tees (on the remaining double swing bars) to the main monkey bar ladder legs.  
Check the swing bars are level then fully tighten all grub screws.

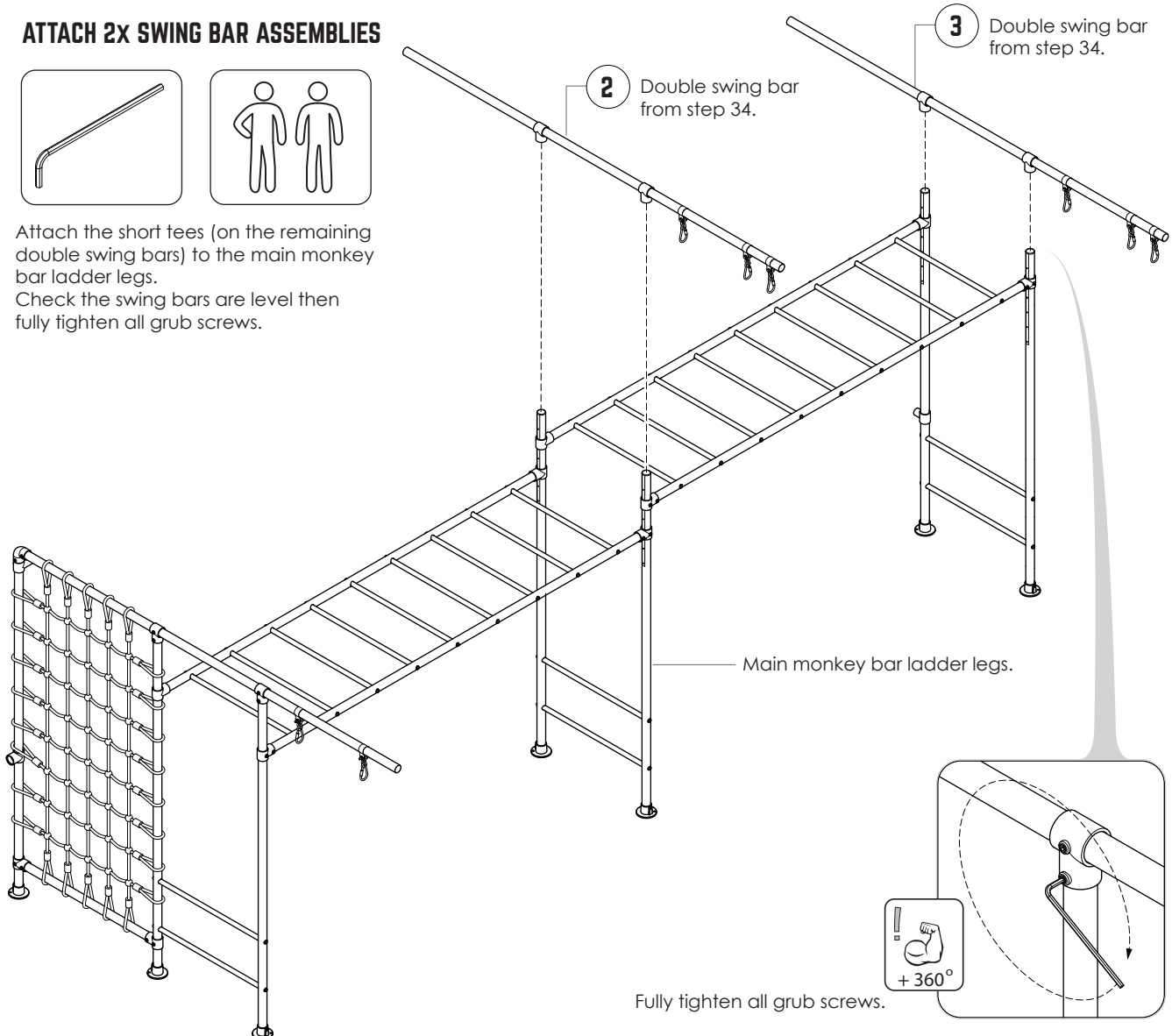

**39 ASSEMBLE SWING BAR LEGS x5**

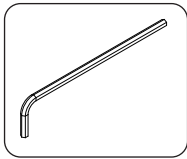

1. On flat level ground slide on all fittings.

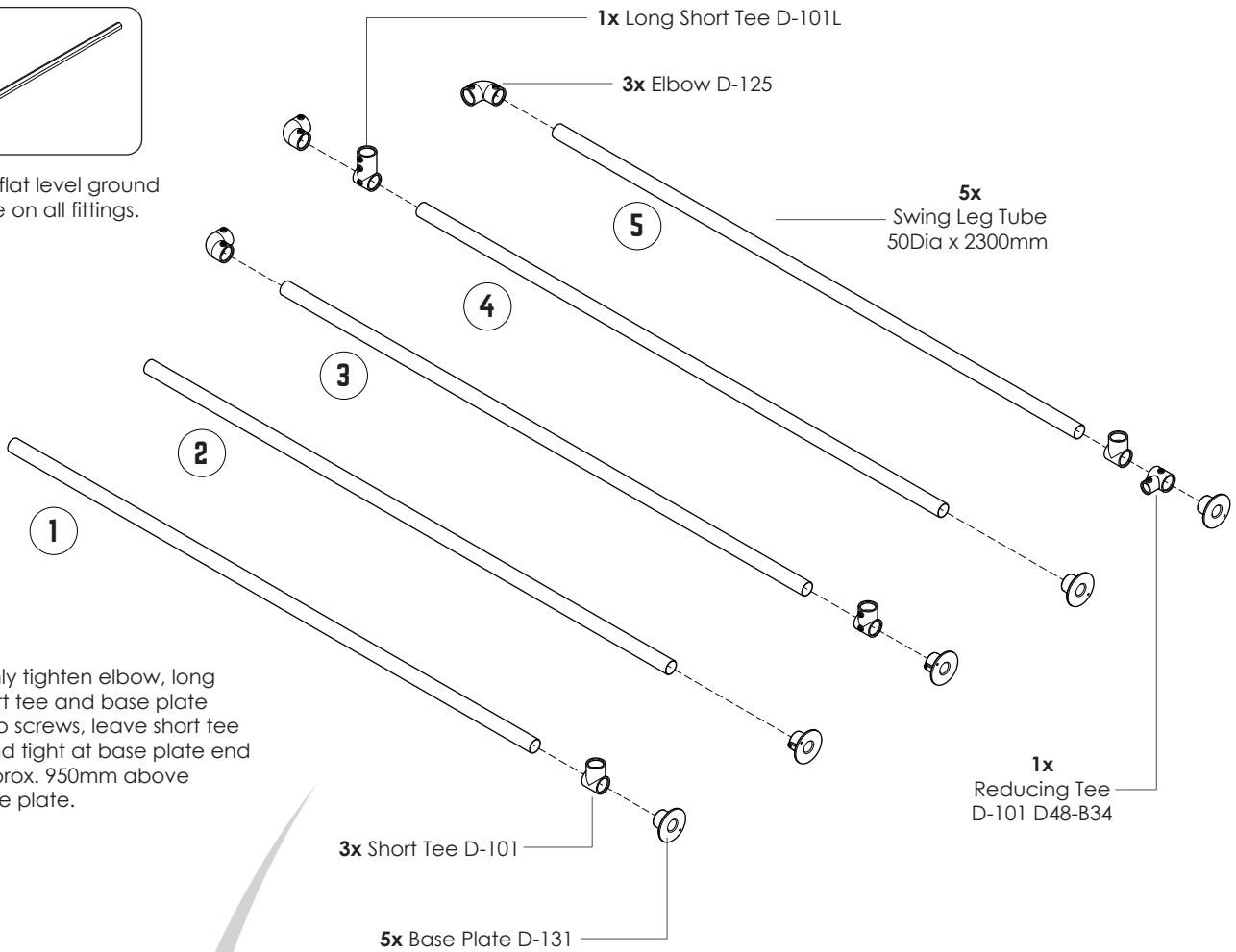

2. Firmly tighten elbow, long short tee and base plate grub screws, leave short tee hand tight at base plate end approx. 950mm above base plate.

**5X SWING BAR LEGS ASSEMBLED**

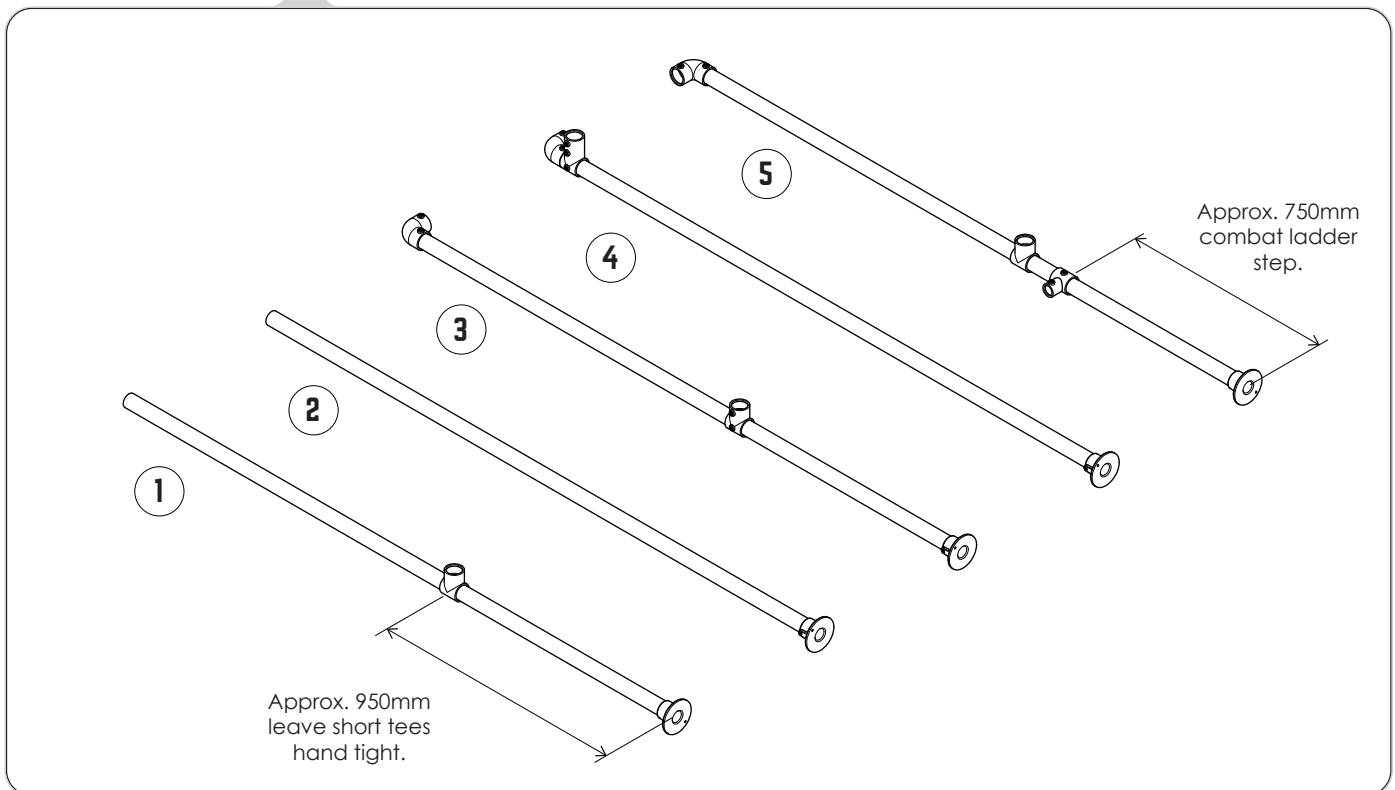

## 40 ASSEMBLE ACCESSORIES BAR

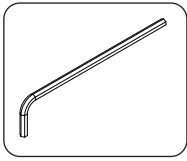

Slide and fully tighten 2x swing hooks onto the accessories bar. Centre and space approximately 2250mm apart.

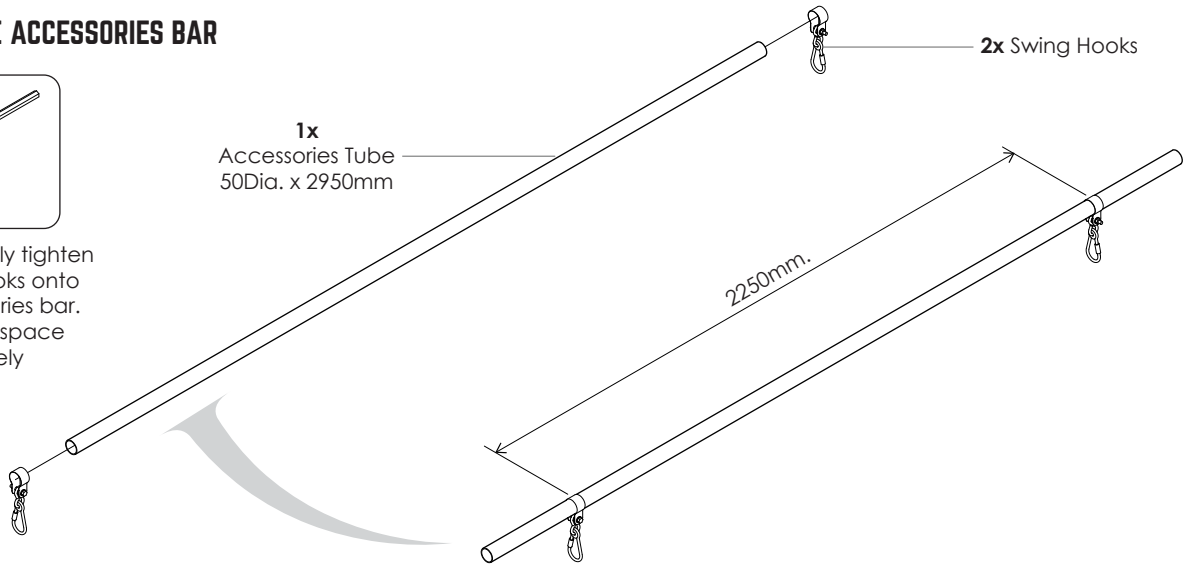

## 41 ATTACH LEGS X3 (3, 4 & 5) & COMBAT STEP

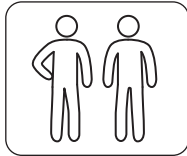
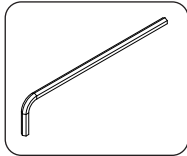

Slide 4 short tees onto double swing bars and leave loose for later adjustment.

With 2 people attach accessories bar into the long short tee on leg 4, then attach onto double swing bar and long short tee at cargo net end.

Attach leg 5 with step tube followed by leg 3. Fully tighten all grub screws.

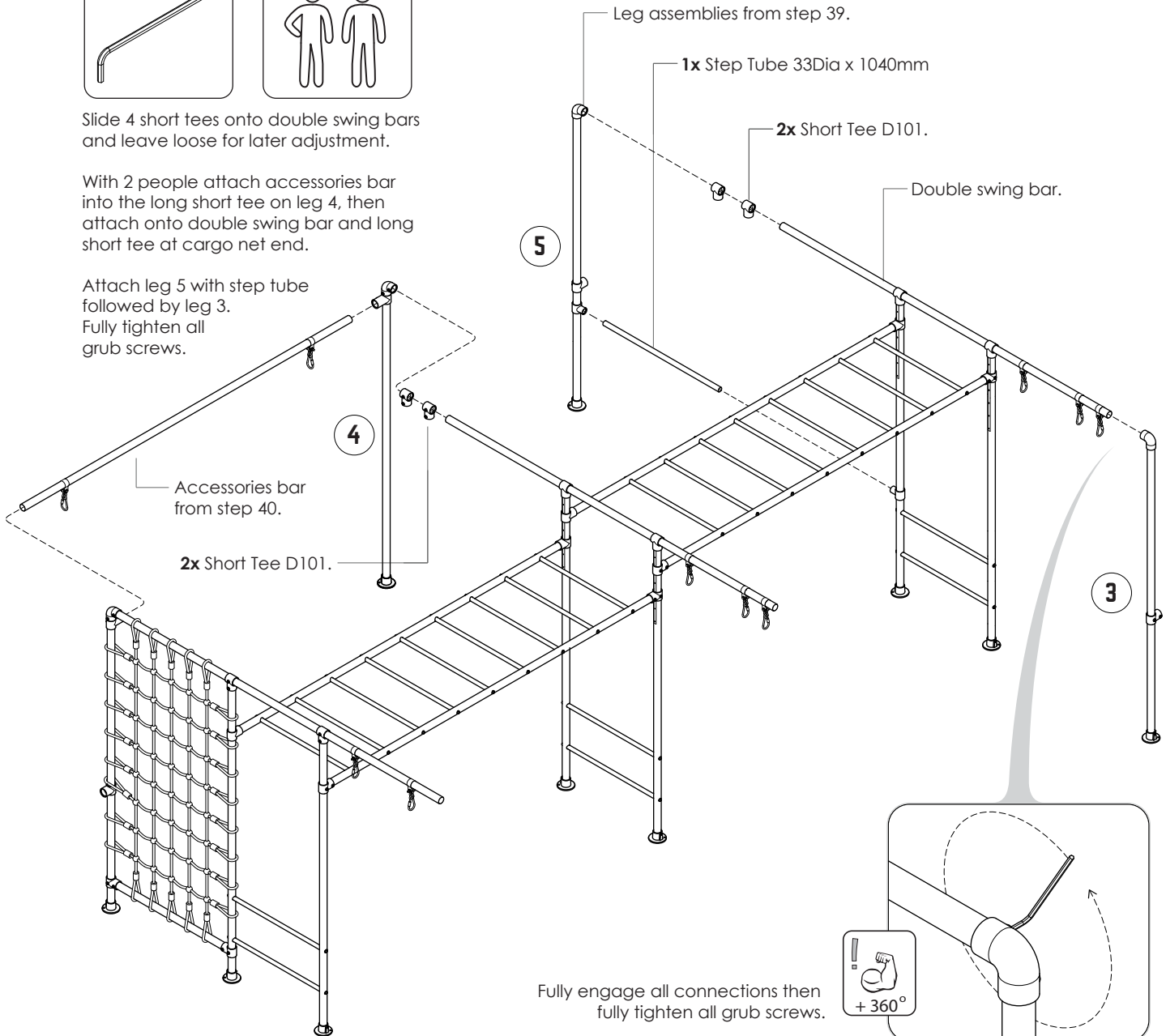

Fully engage all connections then fully tighten all grub screws.



## 42 ASSEMBLE EXTENSION TUBES & TIGHTEN

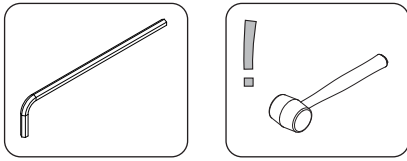

1. Tap end caps into extension tube ends.
2. Insert extension tubes half way into extra long tees and fully tighten all grub screws.

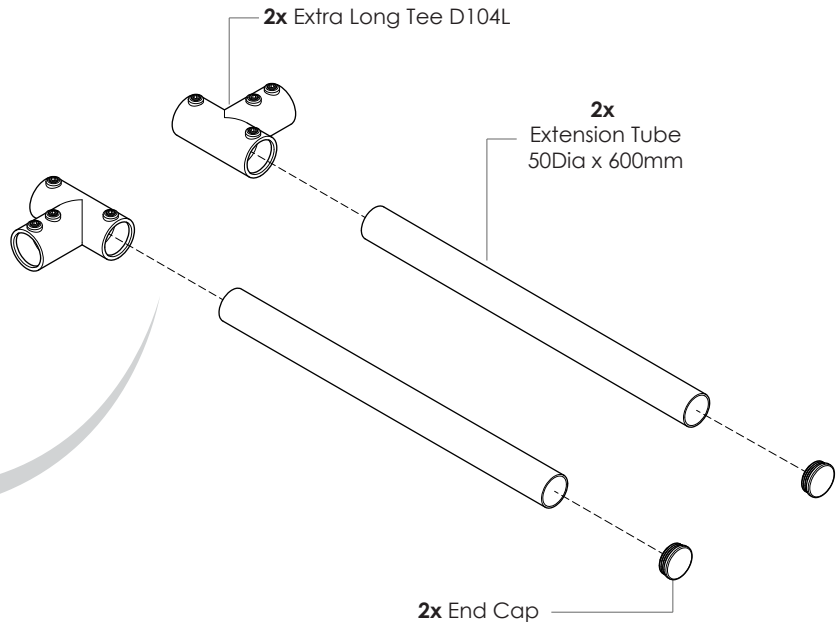
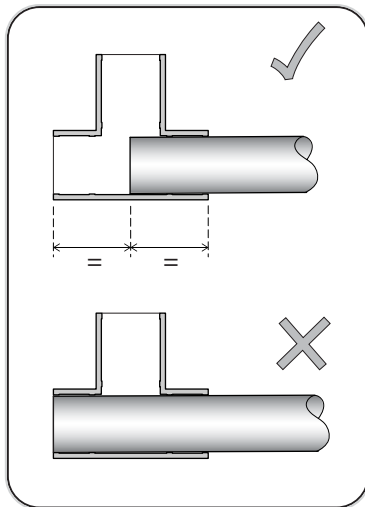
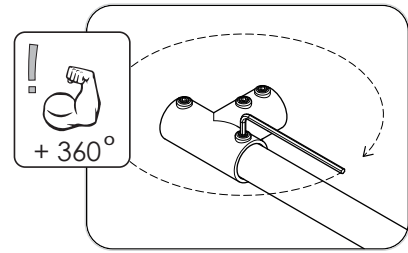

## 43 CONNECT EXTENSION TUBES TO LEGS X2

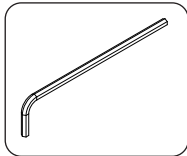

1. Slide swivel braces onto lowered legs ensuring the grub screws are facing the base plate, leave hand tight for later adjustment.
2. Attach extension tube. Ensure inserted leg (A) hits extension tube (B). Firmly tighten grub screws & repeat both sides. Leave swivel brace (C) loose on leg.

Grub screw facing downwards.

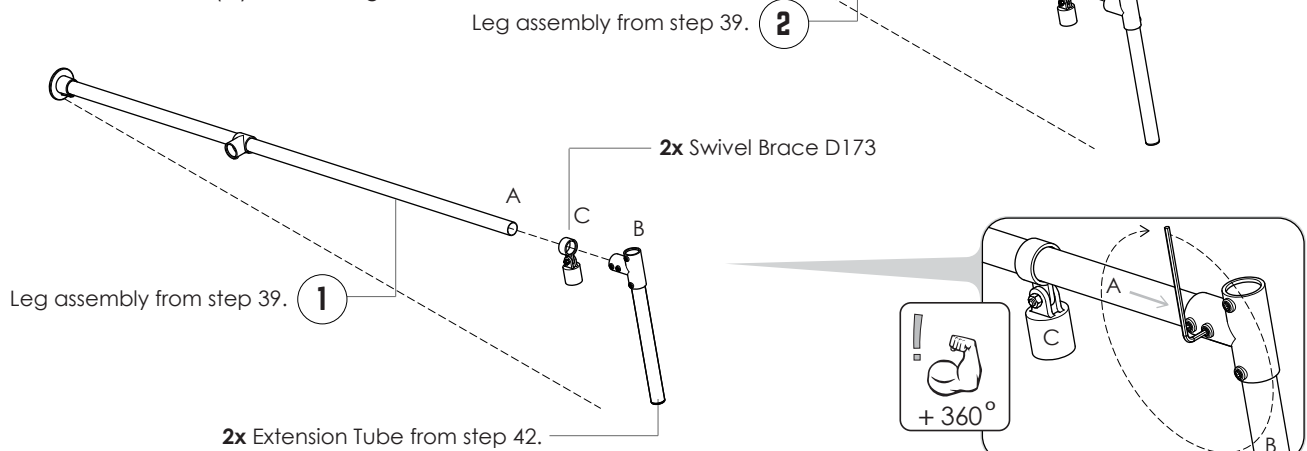
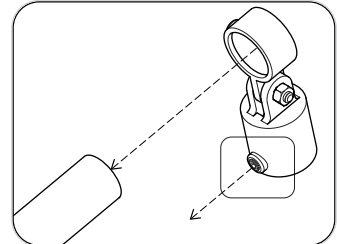

# 44 ASSEMBLE FLOATING FLYING FOX FRAME

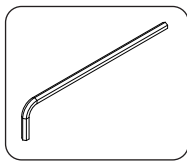

1. Slide trolley, rubber stoppers and swivel braces onto flying fox tube.
2. Slide long short tees onto assembled legs 1 & 2 from step 43. Insert the flying fox tube into the long short tees and make sure the tube is butted up 100% to the extension tube as per detail below.
3. After hearing the clunk sound firmly tighten grub screws on long short tees. Leave swivel brace loose for later adjustment.

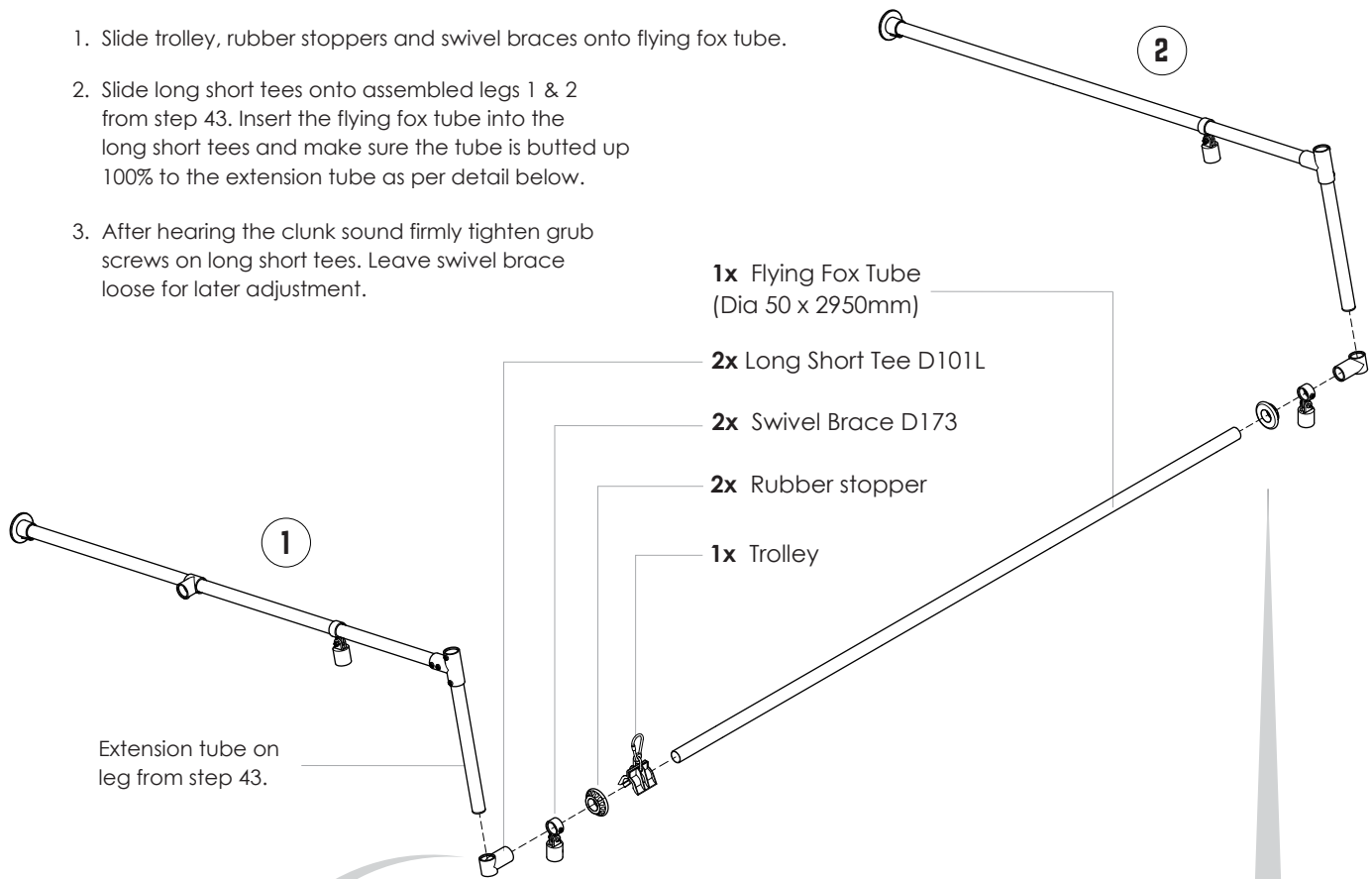

Extension tube on leg from step 43.

1x Flying Fox Tube  
(Dia 50 x 2950mm)

2x Long Short Tee D101L

2x Swivel Brace D173

2x Rubber stopper

1x Trolley

Leave swivel brace loose.

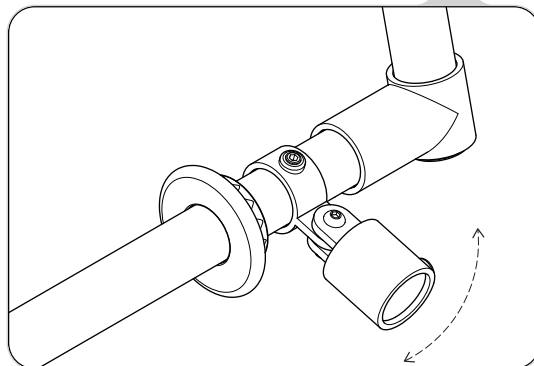

Firmly tighten all extra long tee grub screws.

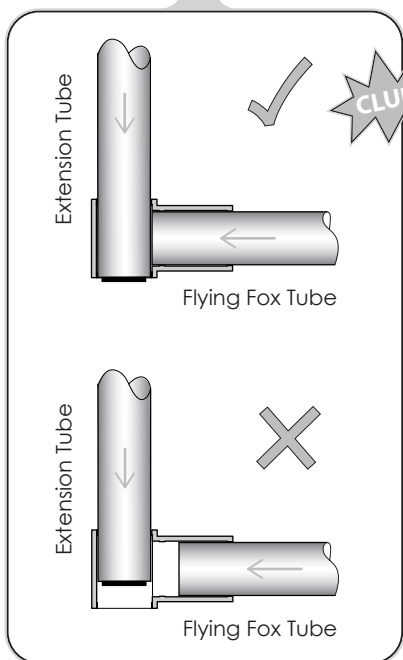
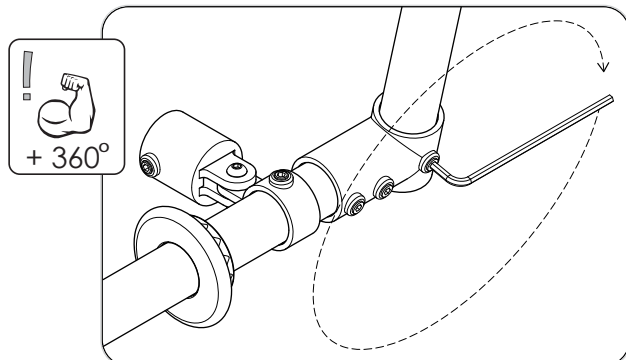



## 45 CONNECT THE BRACE TUBES.

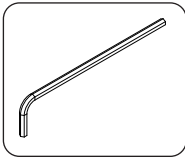

Fit 2x 600mm brace tubes into position by rotating and sliding swivel brace fittings.

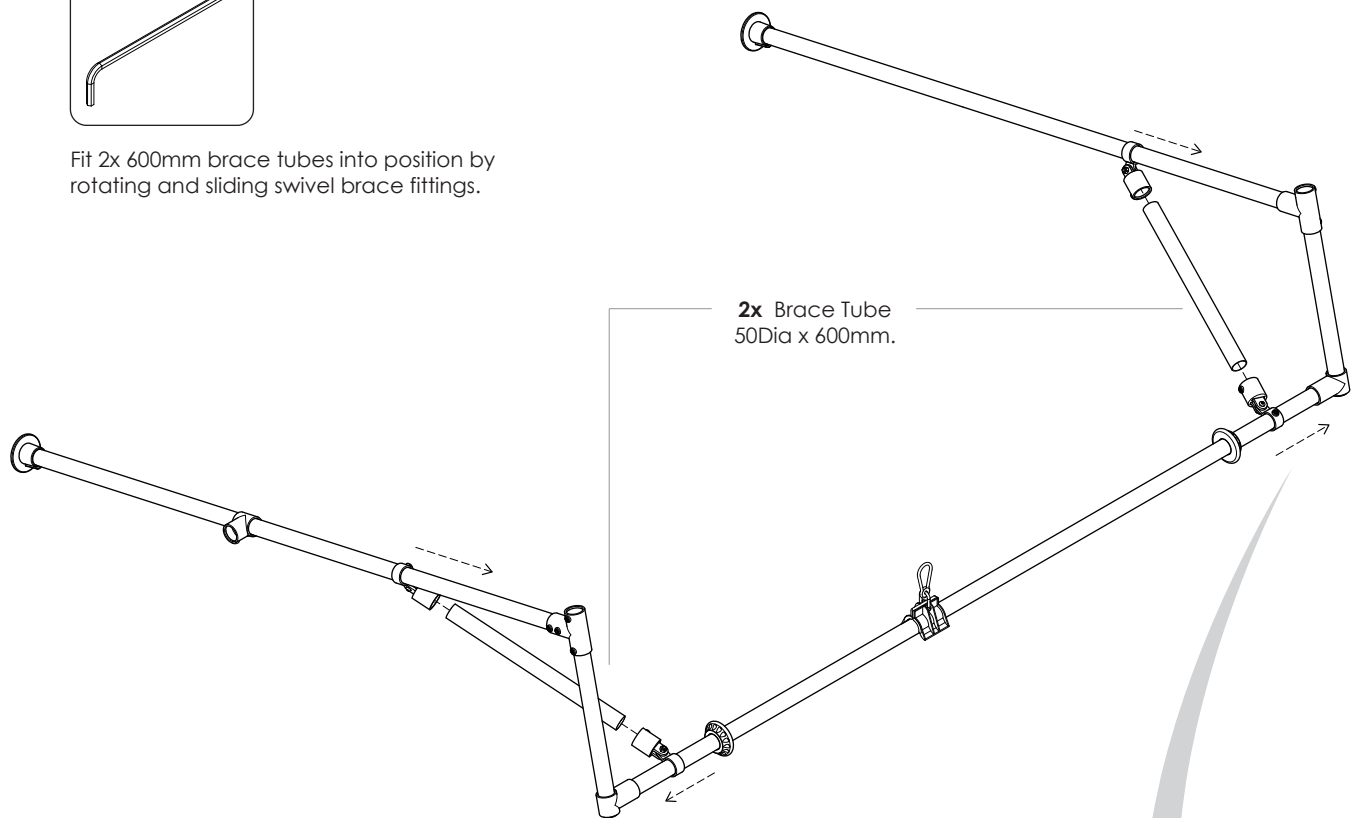

### ORDER OF STEPS:

1. Slide brace tubes into swivel braces (A) & (B).
2. Tighten grub screws on (A) & (B).
3. Slide (D) hard up against long short tee (X).
4. Tighten grub screw on (D)
4. Slide (C) towards extra long tee (Y).
5. Tighten grub screws on (C) whilst pushing (C) towards (Y).

### APPLY TO BOTH ENDS

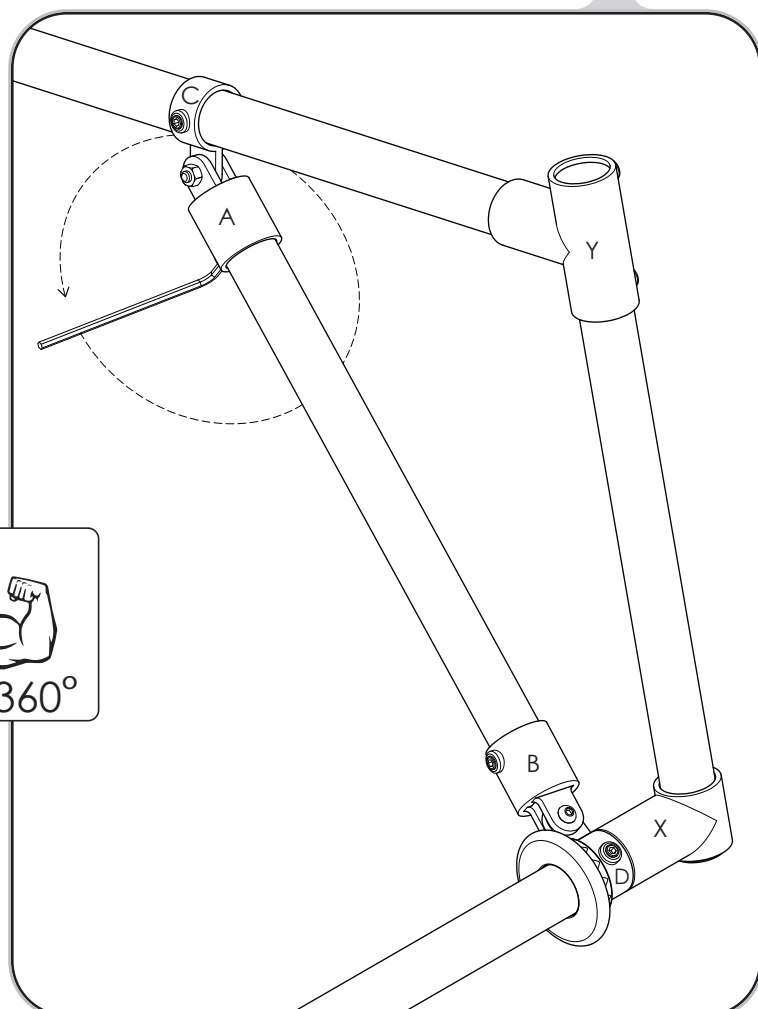
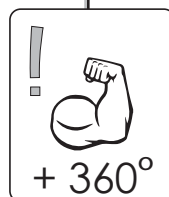

## 46 LIFT FLOATING FLYING FOX INTO POSITION.

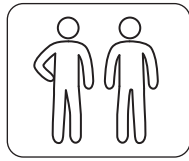
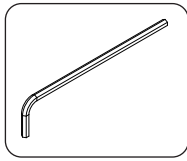

With two people lift floating flying fox into position and fully tighten grub screws on extra long tees.

### WARNING:

Be aware of trolley catching fingers whilst raising into position. It is a good idea to temporarily tie or tape it in a fixed position.

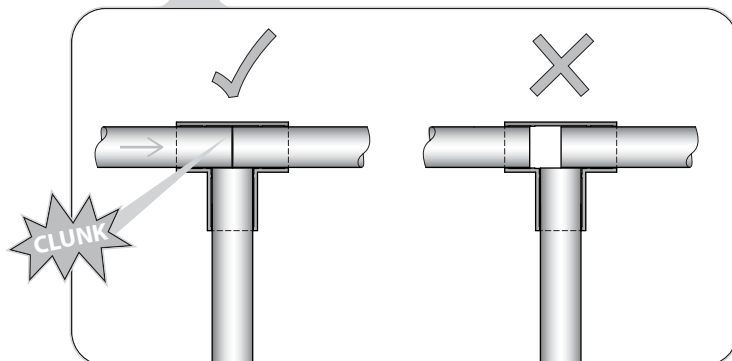
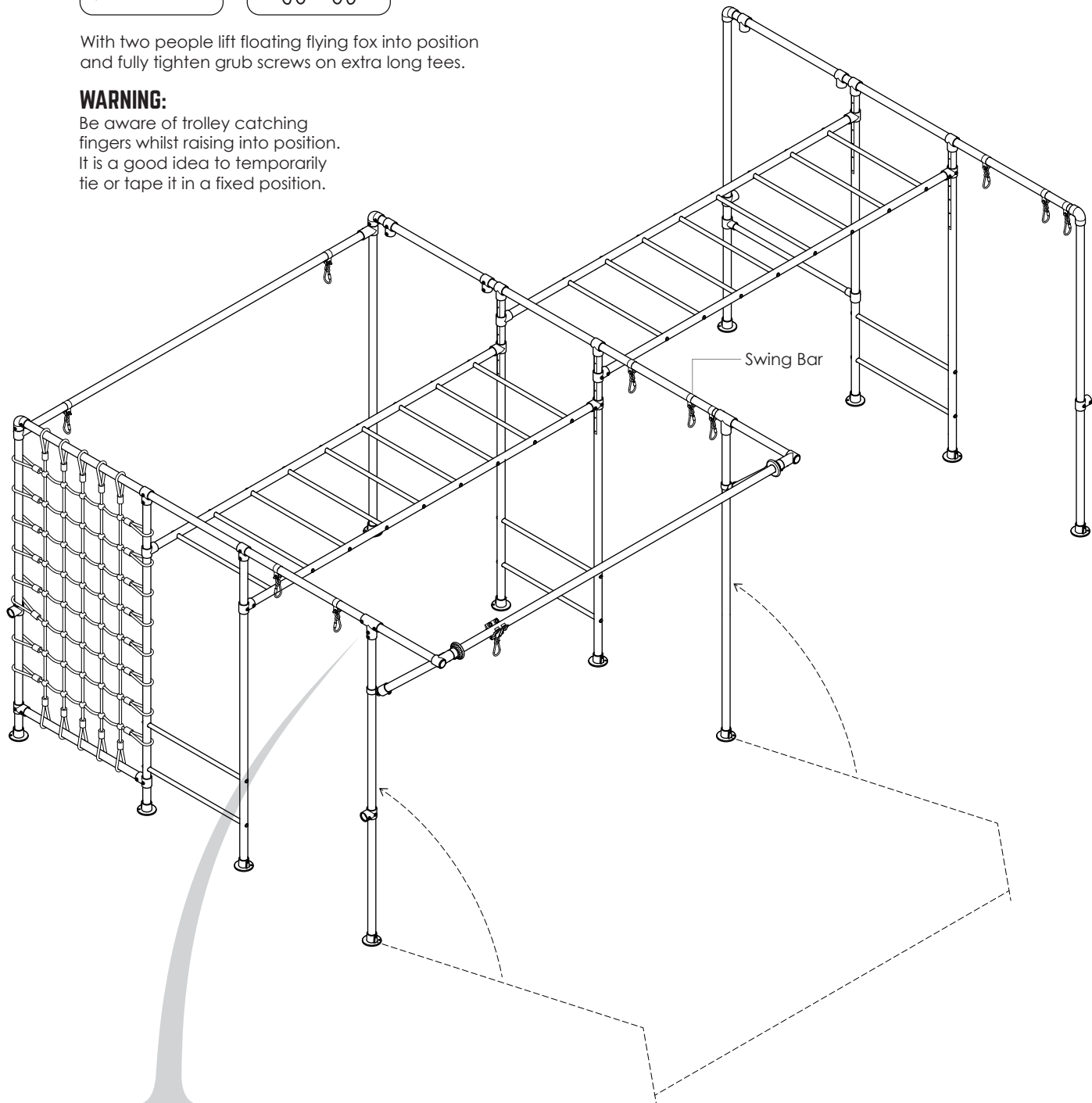

Ensure swing bar is fully engaged into extra long tee.

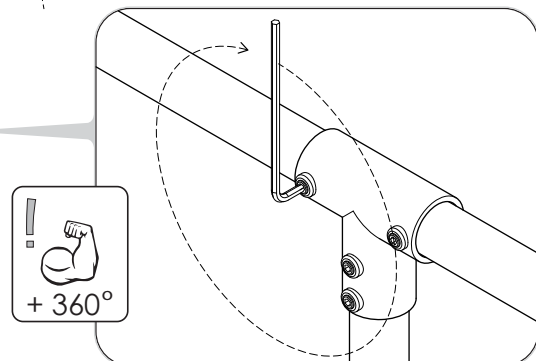

Fully tighten extra long tee grub screws both ends.

# ASSEMBLY INSTRUCTIONS - COMBAT LADDER ASSEMBLY

## 47 ASSEMBLE COMBAT LADDER JOINER x2

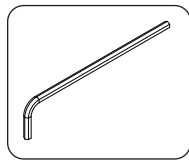
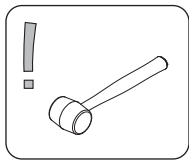

Insert plastic end caps into top tubes. Slide on 145° 3 way fittings and position as below.

Hand tighten all bolts to enable adjustment during assembly.

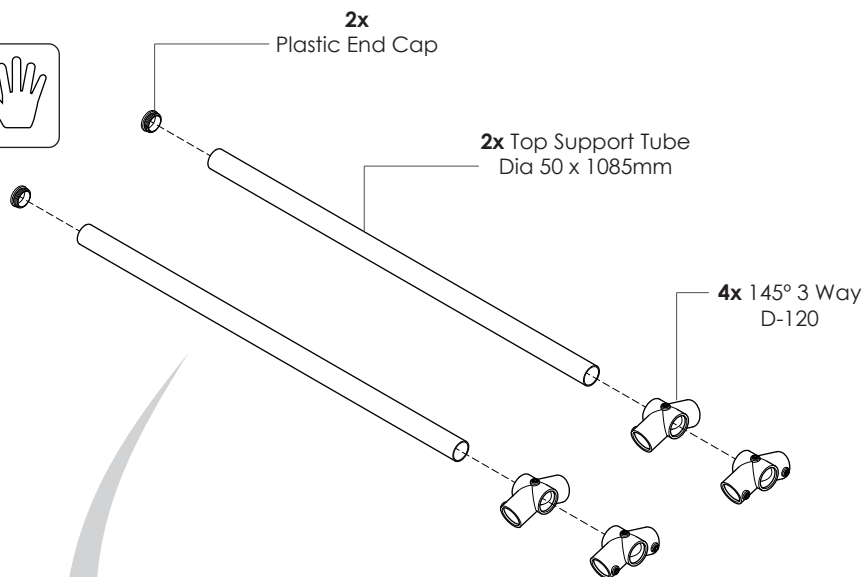

### 2x COMBAT LADDER JOINERS ASSEMBLED

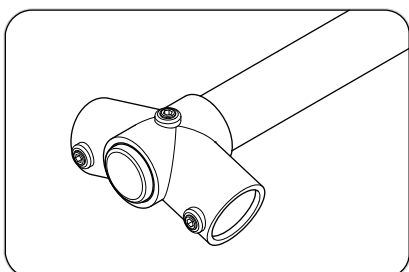

Ensure plastic end caps in top tubes are flush with end of 145° fitting.

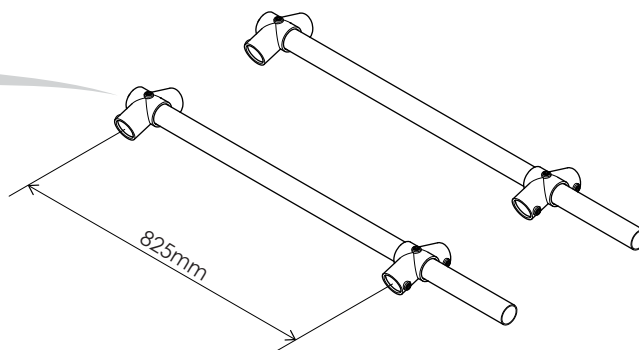

**NOTE:** FOR THE FOLLOWING STEPS ASSEMBLY IS ON THE OTHER SIDE OF THE FRAME. THE VIEW SHOWN IS OF THE OTHER SIDE AND IS OF THE CENTRAL LEGS AND SWING BAR (2)

## 48 ATTACH FIRST COMBAT LADDER & JOINER

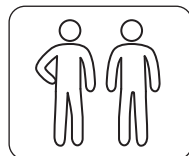
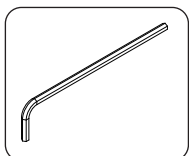

Attach combat ladder to short tees on central swing bar (same side as accessories bar/ opposite site to floating flying fox). Position centrally. Attach combat joiner to combat ladder.

1x Combat Ladder from step 11.

1x Combat Joiner from step 47.

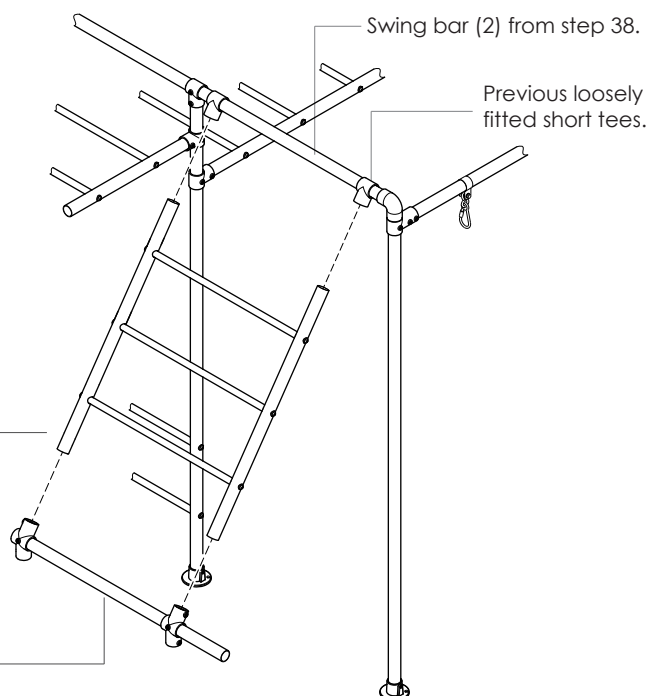

## 49 ATTACH SECOND COMBAT LADDER & JOINER

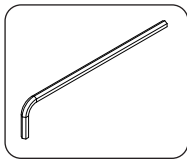

Attach second combat ladder to 145° joiner then attach second joiner.

1x  
Combat Ladder  
from step 11.

1x  
Combat Joiner  
from step 47.

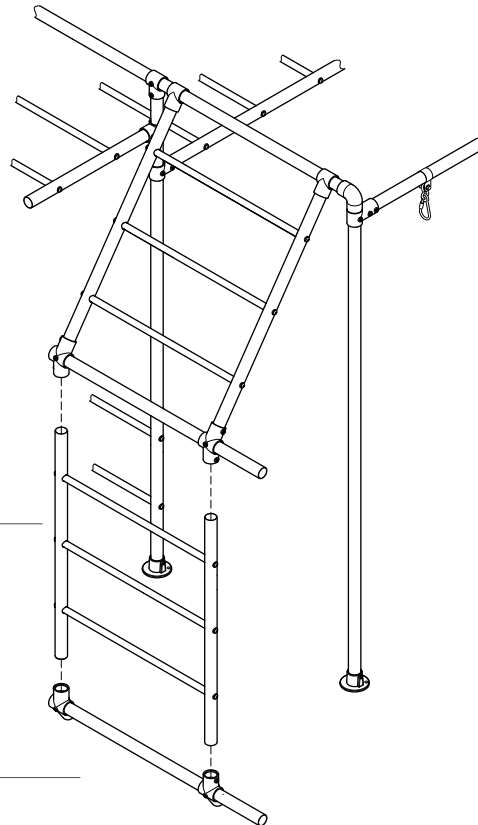

## 50 ATTACH THIRD COMBAT LADDER

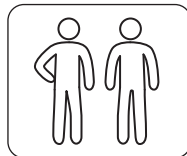
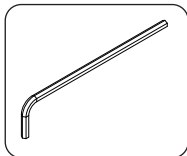

1. Attach final combat ladder to 145° fitting.
2. Fully tighten all fixings except onto swing bar.

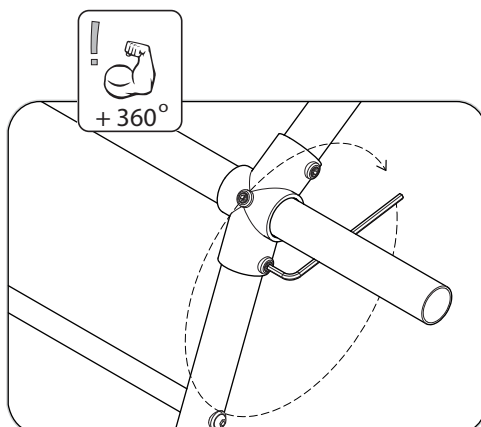

Leave short tee grub screws on swing bar loose.

1x  
Combat Ladder  
from step 11.

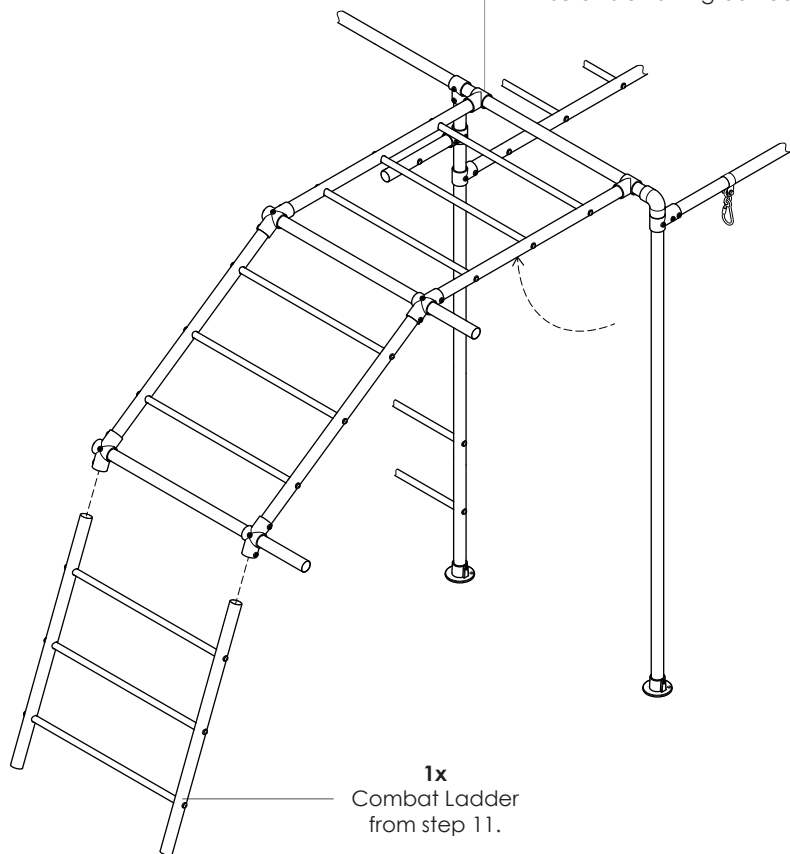

## 51 ASSEMBLE SUPPORT SECTION

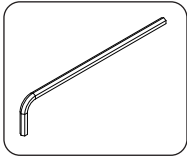

1. On flat level ground assemble combat ladder support section. Tighten grub screws on elbows. Leave short tee and swing hook loose on support tube.
2. Flip over assembly for installation

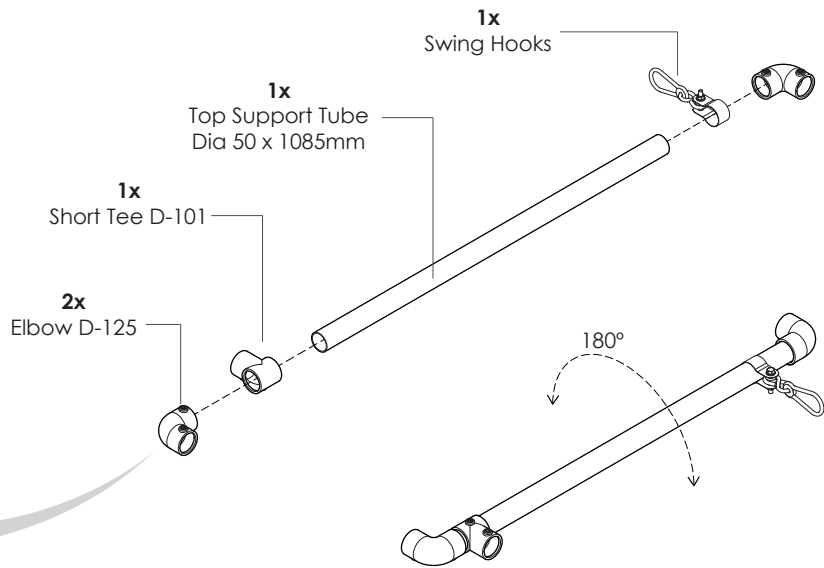
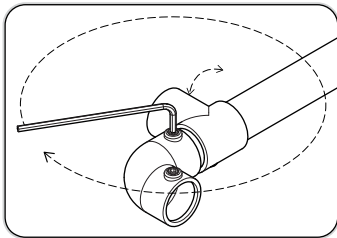

## 52 ATTACH SUPPORT SECTION TO COMBAT LADDER

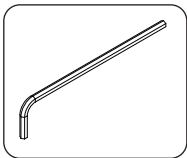

Tighten all elbow grub screws.

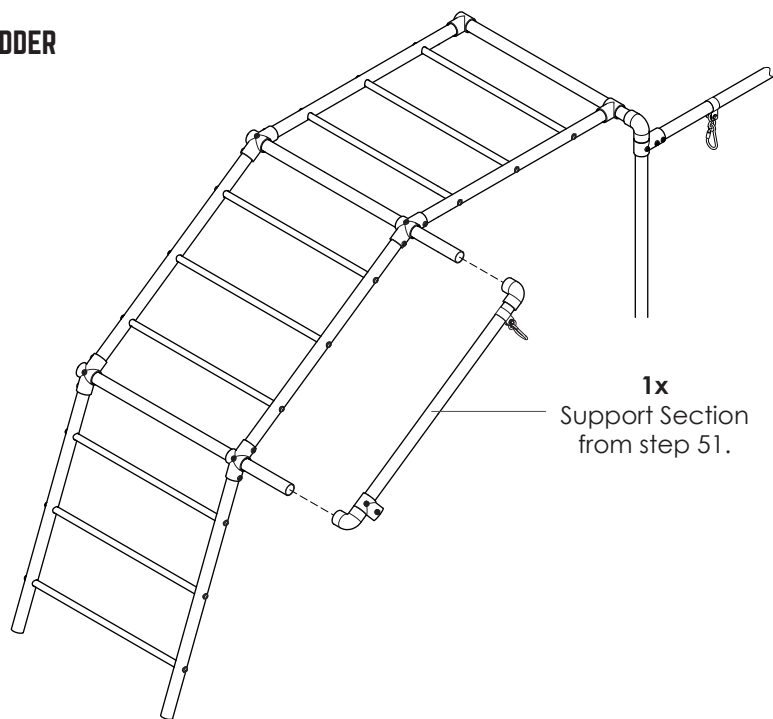

## 53 ASSEMBLE POWER POLE

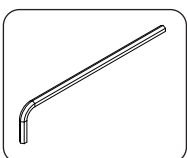

1. Tighten grub screw on 4 hole base plate.

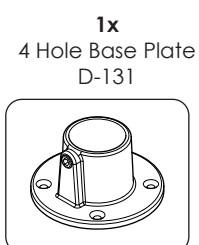

1x  
4 Hole Base Plate  
D-131

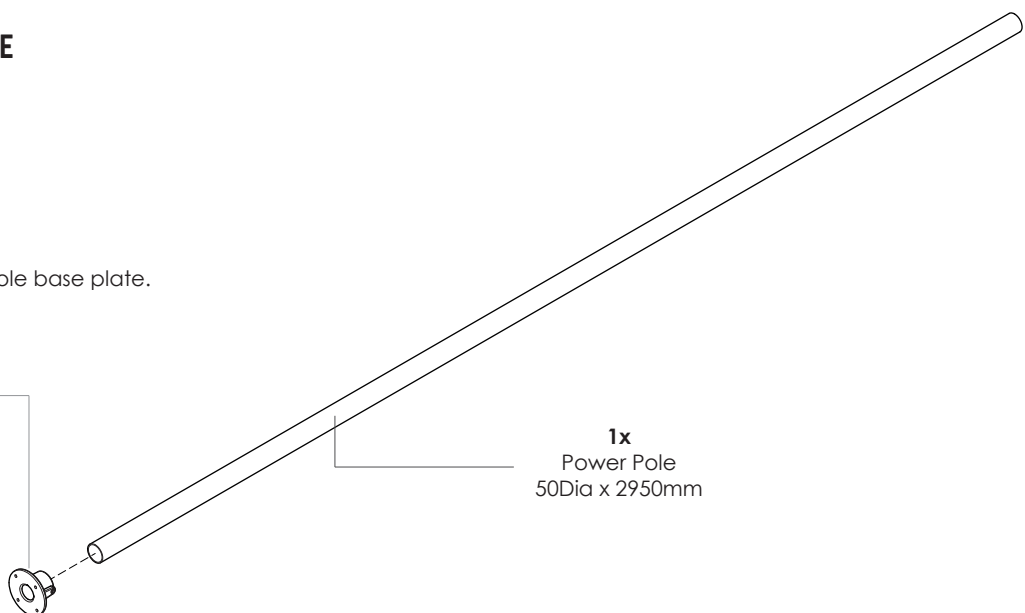

1x  
Power Pole  
50Dia x 2950mm

## 54 ATTACH POWER POLE TO COMBAT LADDER

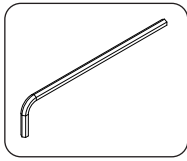

Fully tighten short tee to power pole. Leave grub screw on short tee connecting to support tube loose for next step.

Leave short tee loose on support tube, tighten on power pole.

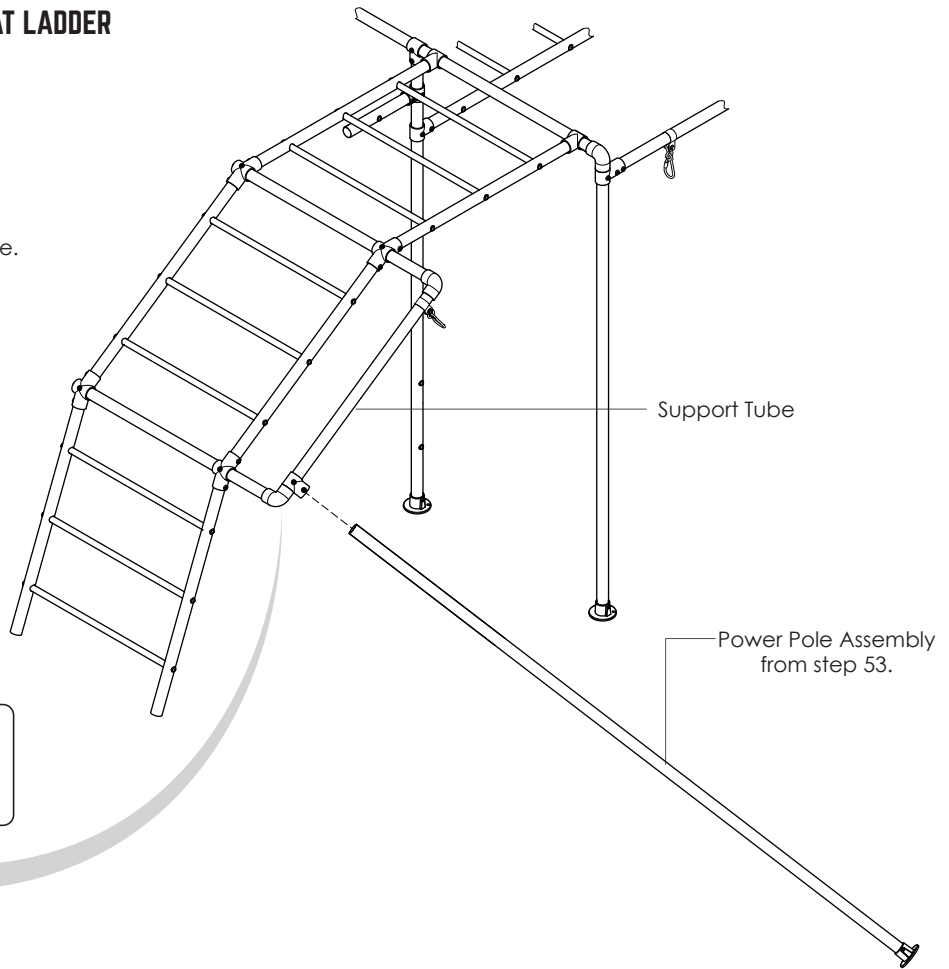
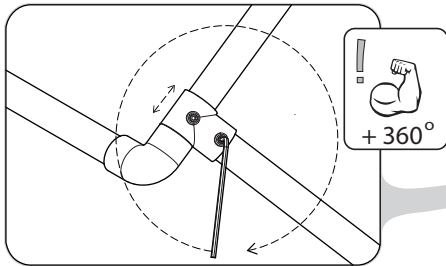

## 55 LIFT COMBAT LADDER INTO POSITION

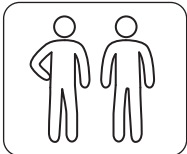

1. By pushing inwards and upwards on the power pole move the combat ladder up into position. NOTE: To avoid clashing between combat ladder assembly and swing bar you may need to loosen short tee (A) to lever swing bar outwards. Retighten after.
2. The second person up a 3m ladder should guide the combat ladder into the short tees.

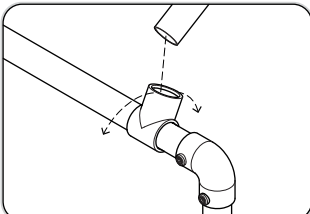

3. Fully Tighten all grub screws.

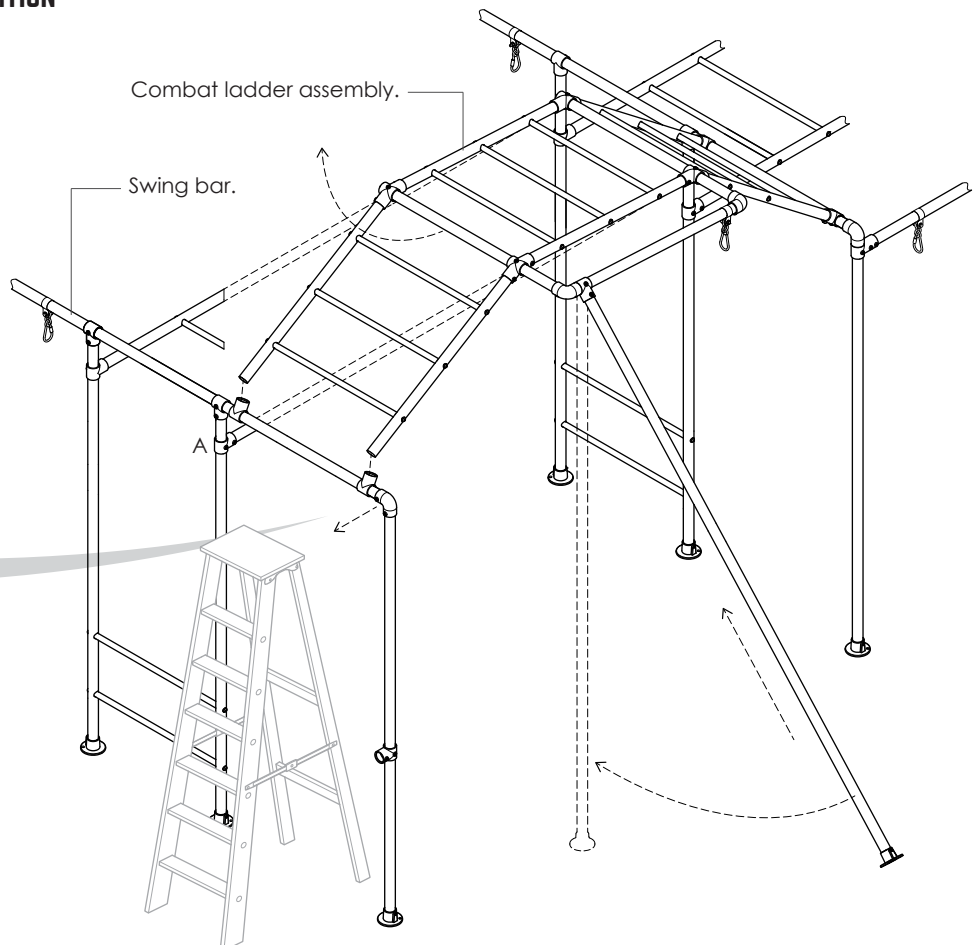
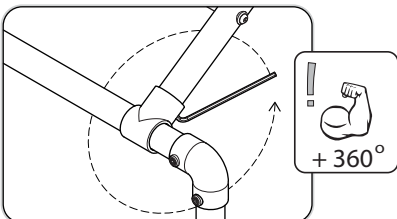

**NOTE:** FOR THE REMAINING STEPS ASSEMBLY DIAGRAMS RETURN TO THE ORIGINAL DRAWN SIDE OF THE FRAME.

## 56 SECURE TO GROUND

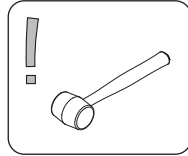
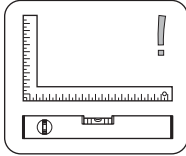

1. Check the frame is level and square.
2. Check all grub screws are firmly tightened.
2. Hammer in all remaining pegs x10.

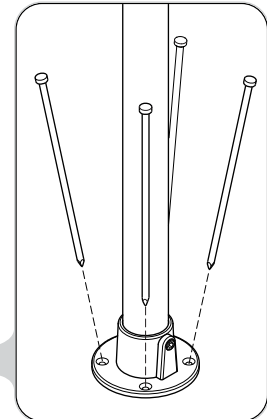

Base plate A

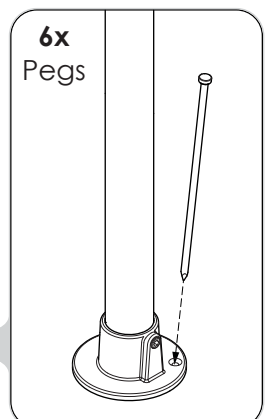
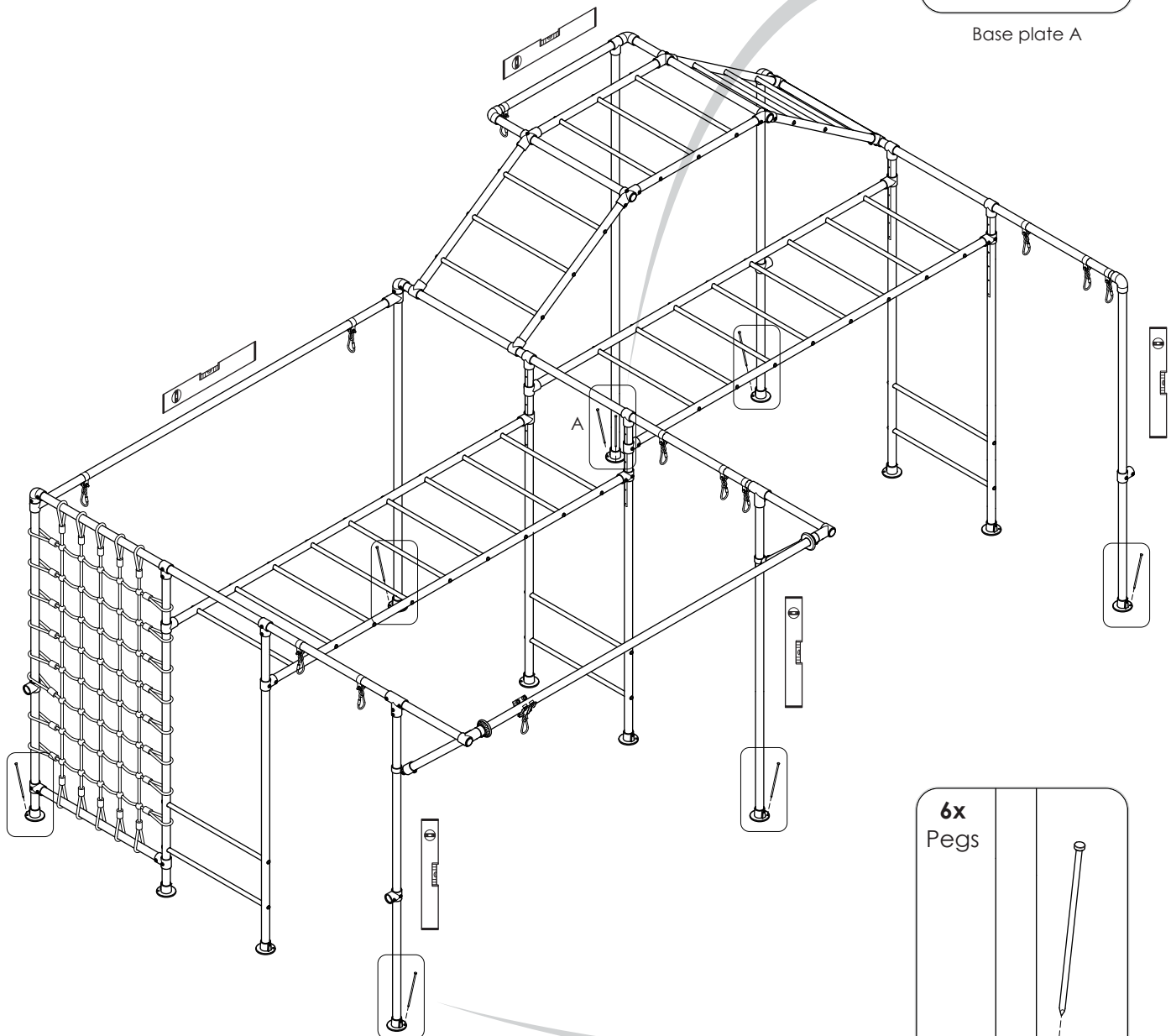

6x  
Pegs

All other base plates.

## 57 ATTACH TWIRLY WHIRLY BARS x4

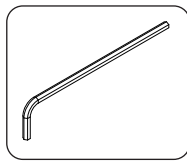

1. Adjust & rotate short tees A,B,C & D to align level with twirly whirly bars.
2. Tighten all grub screws fixing twirly whirlys to legs.

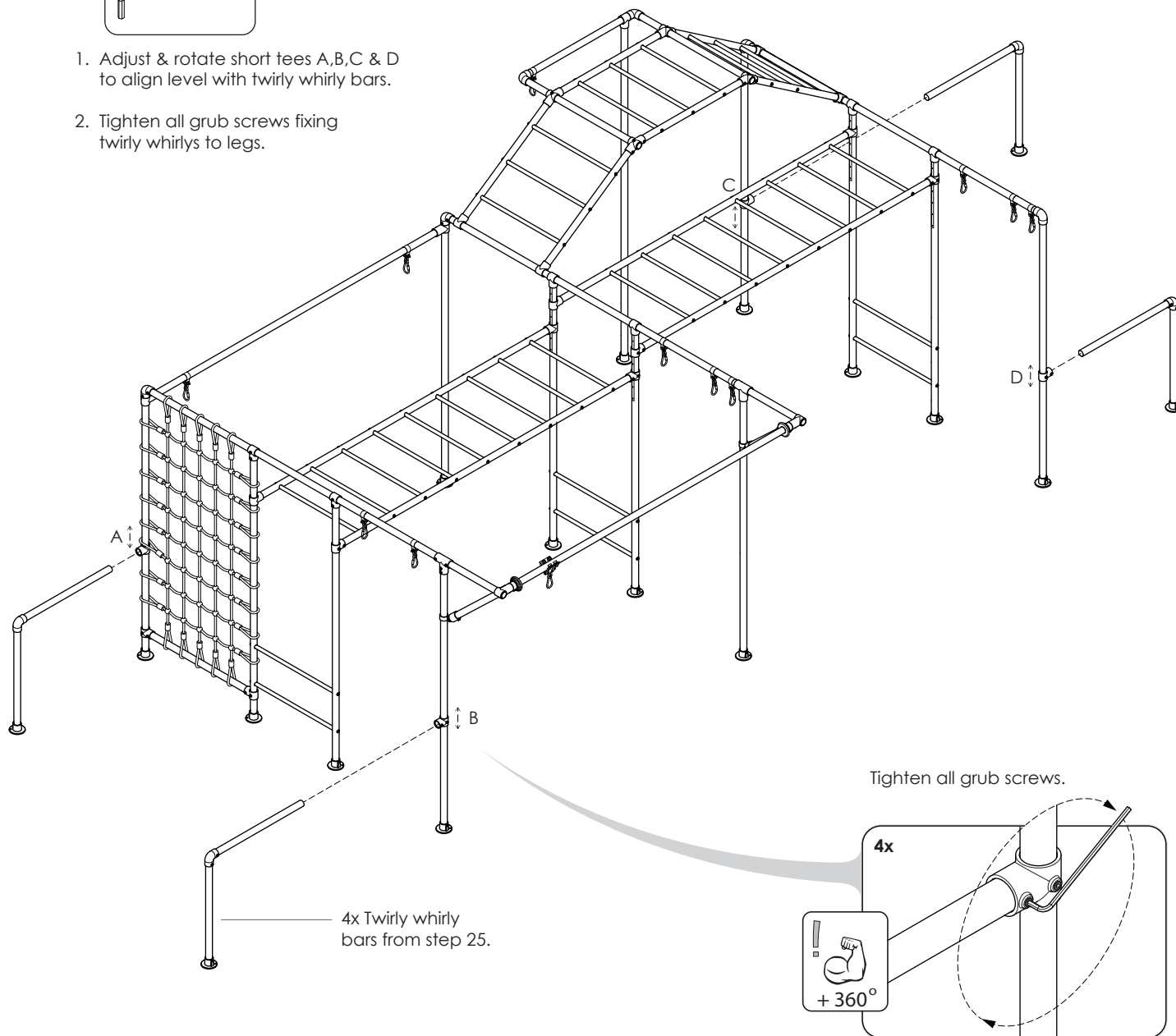

4x Twirly whirly bars from step 25.

## 58 CHECK ALL FITTING GRUB SCREWS ARE FULLY TIGHTENED

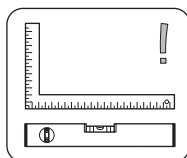
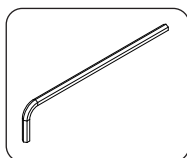

1. Ensure frame is square and level.
2. Firmly tighten all grub screws and bolts.



**59** LOAD YOUR TWIRLY WHIRLY BARS x4

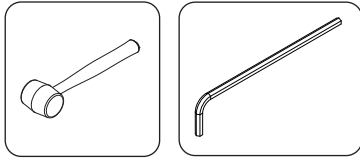

To reduce movement in your frame load your twirly whirly bars as follows.

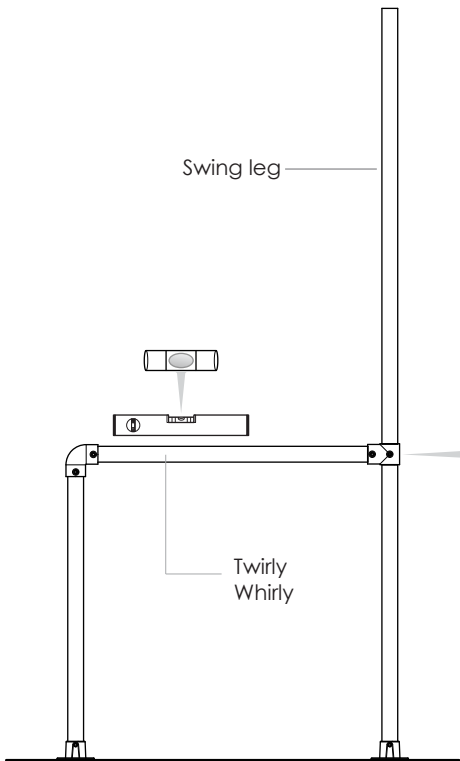

**1.** Ensure twirly whirly is level and square & swing leg is pegged down.

**2.** Loosen the grub screw fixing the short tee to the swing leg.

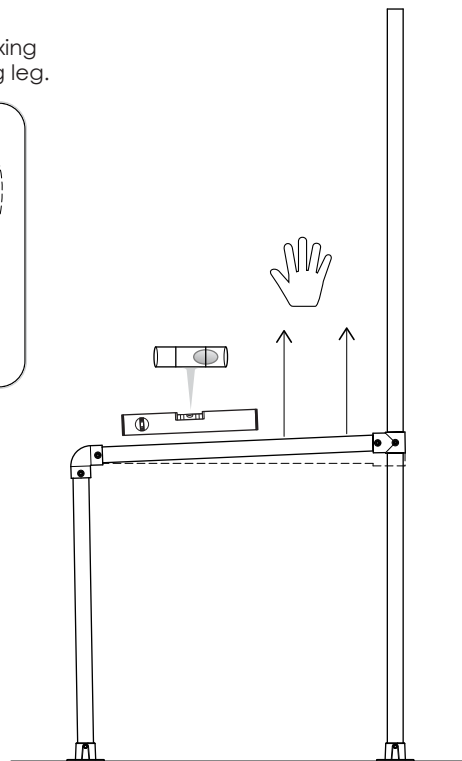
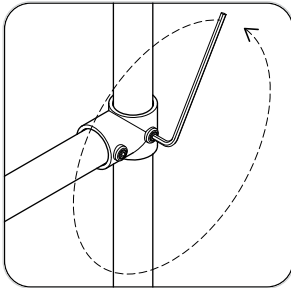

**3.** Pull upwards on the twirly whirly bar to make a slight angle. (Half a bubble off center on the level)

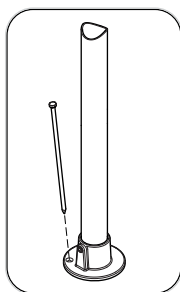

**4.** Peg down base plates on twirly whirly.

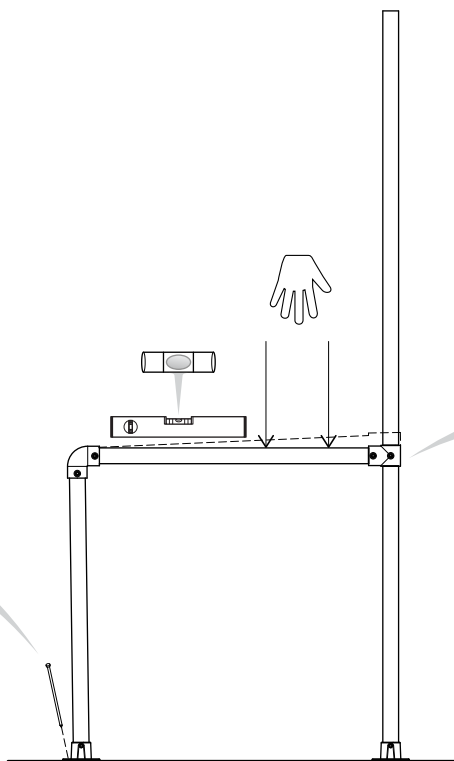

**5.** Push down on the twirly whirly bar until horizontal bar is level.

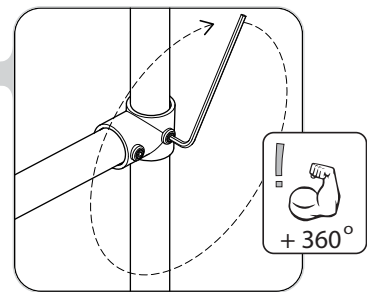

**6.** Tighten grub screw fixing the short tee to the swing leg tube. Apply to all twirly whirlys.

REFER TO VIDEO SECTION OF WEBSITE [HTTP://WWW.FUNKYMONKEYBARS.COM/PAGES/VIDEOS](http://www.funkymonkeybars.com/pages/videos)

## 60 ATTACH ACCESSORIES (IF APPLICABLE)

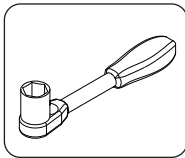

Attach new accessories in desired position (if applicable) and tighten swing hook bolts with ratchet. Refer to individual accessory instructions for installation if supplied.

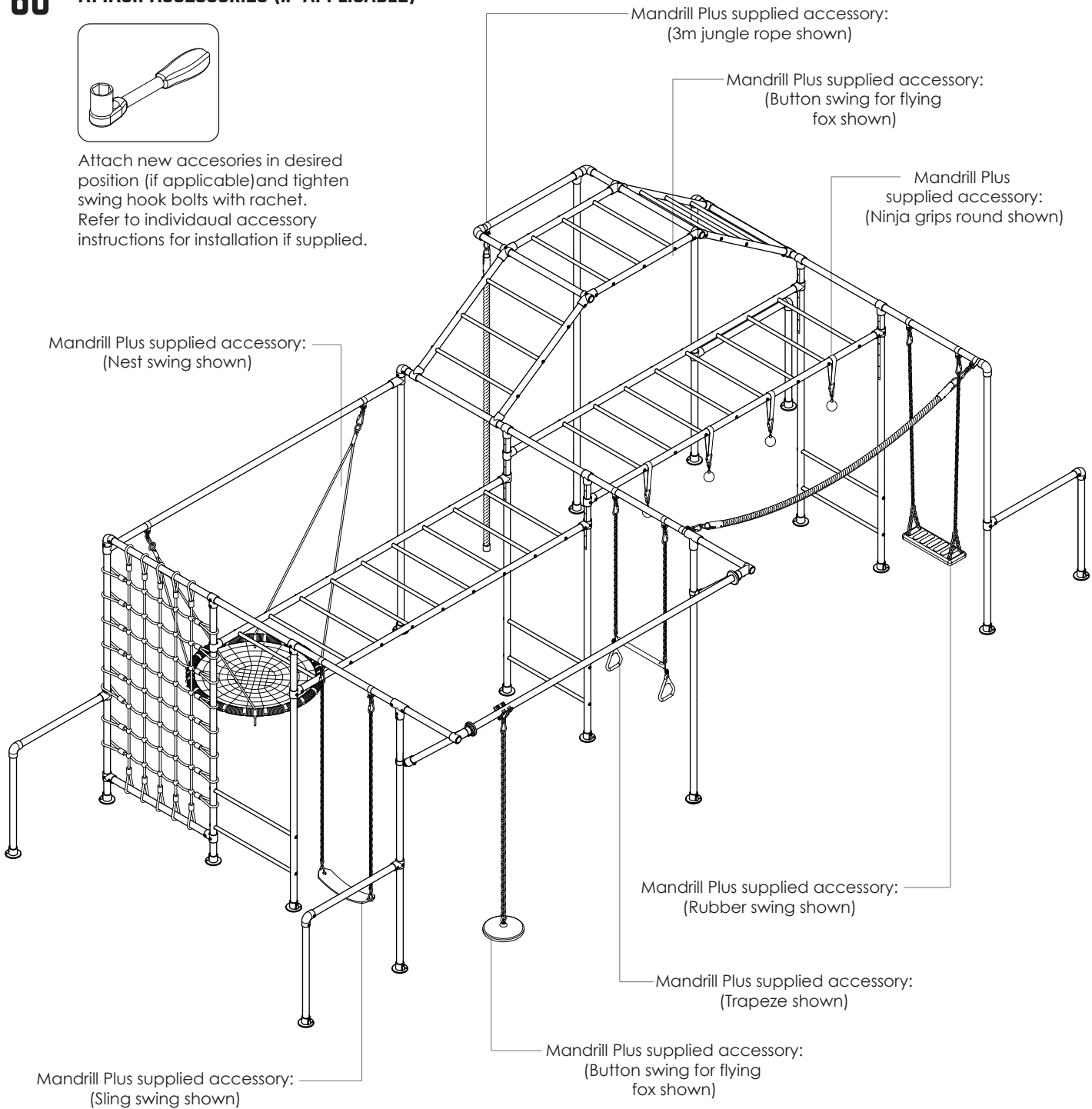

## 61 FINAL CHECKS

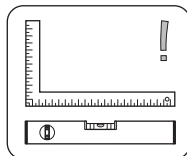
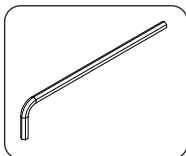

1. Ensure frame is square and level.
2. Firmly tighten all grub screws and bolts.
3. All base plates are pegged down.

Apply your manufacturing sticker to a leg tube.

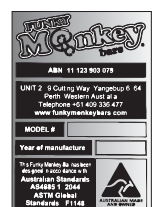

## 62 MAINTENANCE.

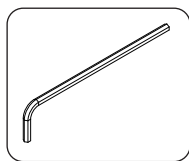
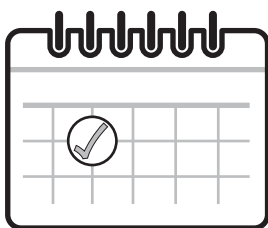

At the beginning of each heavy play session (especially a party) and twice a month during play season ensure;

1. Tighten all hardware - grub screws, nuts and bolts.
2. Pegs are in place and fully secure.
3. Lubricate all metallic moving parts with WD40 or Vaseline - (trolley and swing hooks.)
4. Ensure your frame is level and square.

**FAILURE TO DO SO COULD RESULT IN SERIOUS INJURY OR DEATH.**

**FOR MORE INFORMATION AND ASSEMBLY TIPS  
PLEASE REFER TO OUR WEBSITE VIDEO INSTRUCTION SECTION AT  
[HTTP://WWW.FUNKYMONKEYBARS.COM/PAGES/VIDEOS](http://www.funkymonkeybars.com/pages/videos)**

## 63 HAVE FUN





ABN 72 164 496 520



1300 912 198



info@funkymonkeybars.com



www.funkymonkeybars.com



9 Cutting Way,  
Yangebup WA 6164



WE ARE SOCIAL MONKEYS



Australian Government  
IP Australia

All Funky Monkey Bars® designs are registered and protected under IP Australian certification.