

FUNKY Monkey bars®

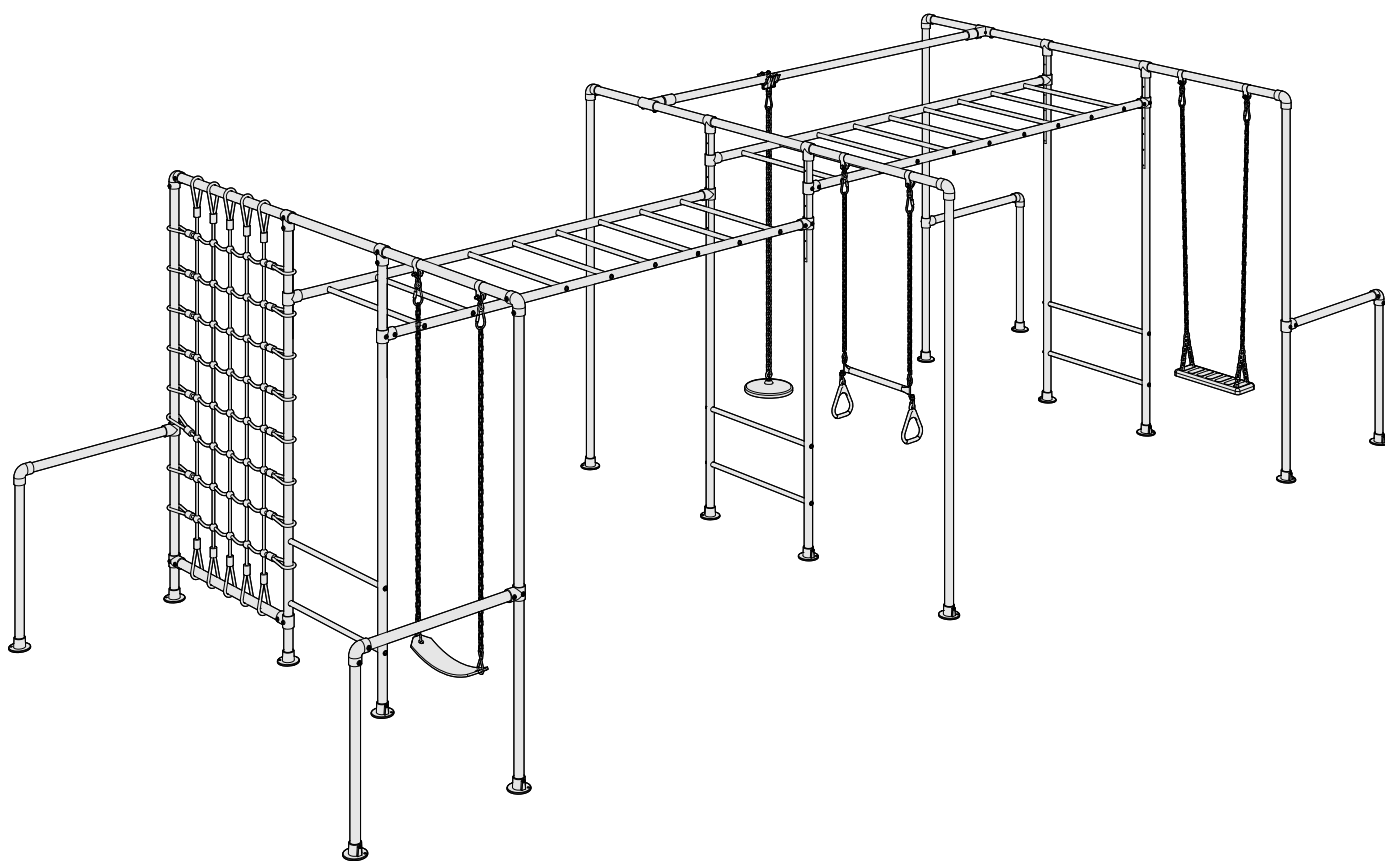

THE MANDRILL ASSEMBLY INSTRUCTIONS

CONTENTS

Warnings	Page 1
Load Rating	Page 3
Dimensions	Page 4
Assembly Tips	Page 5
Inventory	Page 7
Assembly Instructions	Page 9
Ladder Bar Assembly	Page 9
Leg Assembly	Page 12
Twirly Whirly Bar Assembly	Page 17
Main Monkey Bar Assembly	Page 18
Swing Bar Assembly	Page 22
Swing Leg Assembly	Page 25
Flying Fox Assembly	Page 26
Load Twirly Whirly Bars	Page 29
Maintenance	Page 31

WARNING

PLEASE CAREFULLY READ ALL INFORMATION CONTAINED IN THIS ASSEMBLY MANUAL BEFORE YOU INSTALL AND USE YOUR FUNKY MONKEY BARS®.

SAFETY NOTICE

1. Any person handling or using the Funky Monkey Bars® products must follow the instructions as described in this document. The person in charge of assembling and using the equipment must ensure that the recommendations for use given in this document are seen by all users.
2. Only use the Funky Monkey Bars® after they have been fully assembled and after checking that the fittings are tightened properly (*refer to page 5 - Correct Tightening Method*).
3. DO NOT install your Funky Monkey Bars® over concrete, asphalt, packed earth, wood decking or any other hard surface. A fall onto a hard surface can result in serious injury or death.
4. Inspect all grub screws, bolts and nuts at the beginning of each play session to ensure your Funky Monkey Bars® are tight and secure.
5. Ensure all tubes are fully inserted into fittings until you hear the magic "CLUNK" sound.
6. Ensure your Funky Monkey Bars® are properly secure at ALL times. Pegs are in place and inserted fully into the ground.
7. DO NOT exceed the maximum load/weight limit as recommended by Funky Monkey Bars®.
8. Children should be supervised by an adult at all times.
9. Installing a gym/crash mat under the fall zone area of your Funky Monkey Bars® would be recommended for children learning this new skill. This will reduce the chance of injury and build the child's confidence while they build strength and master the skill.
10. Ensure you have thoroughly read your assembly and installation instructions and viewed our on-line installation videos at <https://www.funkymonkeybars.com/blogs/installation-maintenance-videos>
11. DO NOT climb, sit or stand on top of the monkey bar (horizontal ladder) section.
12. DO NOT jump from the top of any section of the monkey bar.
13. DO NOT use your Funky Monkey Bars® when wet as the steel will be slippery.
14. DO NOT attach items to your frame that are not designed specifically to be used with Funky Monkey Bars®, especially lower quality products that have not been approved by Funky Monkey Bars®.
15. Ensure the height of your Funky Monkey Bars® (horizontal ladder) are set at a level that is age appropriate.
16. DO NOT install your Funky Monkey Bars® over or near objects that could interfere with users in an unsafe way. Maintain a clear area around your Funky Monkey Bars®.
17. DO NOT use your Funky Monkey Bars® while under the influence of drugs and alcohol.
18. Wear clothing free of drawstrings, hooks, loops or anything that could get caught while using your Funky Monkey Bars® and result in entanglement and/or strangulation.

ASSEMBLY

1. Keep small children away from the Funky Monkey Bars® during assembly.
2. Do not attempt to use the Funky Monkey Bars® until it is completely assembled and every fitting is tight and secured.
3. Installation typically takes 3-4 hours to complete. Two people are recommended for assembly.
4. Ensure all fittings are tightened to the correct tightening method as described on page 5.
5. Assembly should be carried out on clean, dry, level surface

Please refer to the video section on the Funky Monkey Bars® website for more handy tips and assembly instructions at <http://www.funkymonkeybars.com/pages/videos>

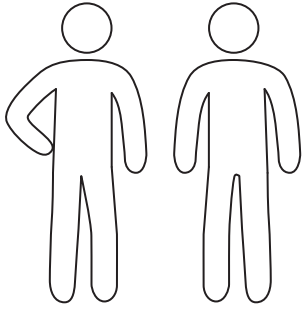

Assembly requires 2 adults.

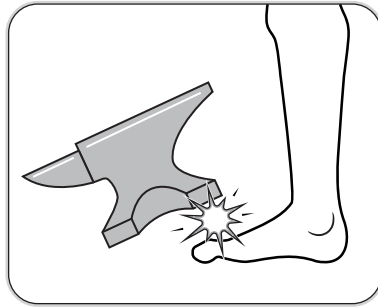

Heavy items !

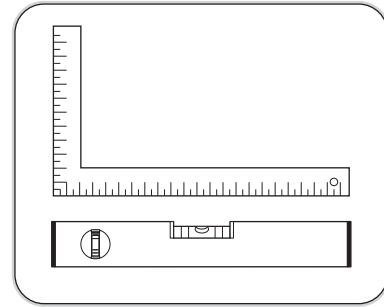

Work on flat level surface.

LOCATION

1. A safe fall zone around your Funky Monkey Bars® is essential. A minimum distance of 1.5m to 2m (5 ft to 6.5ft) is recommended around the elevated hanging points of your Funky Monkey Bars®.
2. Place your Funky Monkey Bars® on level ground, away from any structure or obstruction such as a fence, garage, house, overhanging branches, laundry lines or electrical wires and remove any obstructions beneath your Funky Monkey Bars®.
3. Ensure your Funky Monkey Bars® are positioned away from retaining walls, pool fences, structures and other play equipment. Maintain a clear space around the whole perimeter of your Funky Monkey Bars®.
4. Place your Funky Monkey Bars® on the most level surface available.

MAINTENANCE

1. At the beginning of each heavy play session we recommend the following maintenance processes be performed on your Funky Monkey Bars®:
 - Tighten all bolts, grub screws and applicable hardware (as per page 5)
 - Lubricate all metallic moving parts as per instructions (flying fox, swing hooks etc)
 - Check all protective coverings on bolts, pipes, edges and corners. Replace if they are loose, cracked or missing.
 - Check all moving parts including swing seats, shackles, snap hooks, chains and trolleys for wear, rust, or other deterioration. Replace as needed.
2. Twice a month during play season we would recommend the following maintenance processes be performed on your Funky Monkey Bars®:
 - Tighten all connections and hardware
 - Check all protective coverings on bolts, pipes, edges and corners. Replace if they are loose, cracked or missing.
3. Once a month during play season we would recommend the following maintenance processes be performed on your Funky Monkey Bars®:
 - Lubricate all metallic moving parts as per instructions (flying fox, swing hooks etc). If swings start to squeek then lubricate swing hooks.
 - Check all moving parts including swing seats, ropes, chains and trolleys for wear, rust, or other deterioration. Replace as needed.
 - Owners shall be responsible for maintaining the legibility of any warning labels.

For additional information concerning your Funky Monkey Bars®, please contact our customer service team or check our website for any important updates. Phone - 1300 912 198 or www.funkymonkeybars.com



QUALITY & INDEPENDENT TESTING

At Funky Monkey Bars® we take the quality of our designs and safety very seriously. All Funky Monkey Bars® frames go through a stringent, independent structural testing process prior to being made available for release to our customers.

Our frames are designed within the parameters of the Australian Standard for Playground Equipment AS4685.1:2014.

The structural integrity of our frames has been tested for performance through a combination of engineering calculations and physical testing. The tests have been performed by independent, certified structural engineers in accordance with Australian Standard for Playground Equipment AS4685.1:2014 and European Standards EN1176-1:2008.

The independent testing conducted on The Mandrill certified the frame to a load rating of 1620kgs or 27 users.

LOAD TESTING CERTIFICATION				
DATE OF TEST	MODEL	NUMBER OF USERS	USER LOAD (KG)	LOAD RATING (KG)
Aug 2018	Mandrill	27	60	1620
I hereby confirm all testing was undertaken in accordance with Physical Testing of Structural Integrity requirements of AS 4685.1: 2014 App C / EN 1176-1:2008 ^o except where noted below;				
COMMENTS: The maximum number of users for the Floating Flying Fox is noted as 1 user.				
APPROVED BY: Funky Monkey Bars® 			WITNESSED BY: Independent Engineer 	
DATE : Aug 2018			DATE : Aug 2018	

DIMENSIONS

FUNKY MONKEY BARS® THE MANDRILL OVERALL DIMENSIONS

A minimum of 2.0 Metres clear fall zone is recommended around the elevated hanging points of your Funky Monkey Bars®.

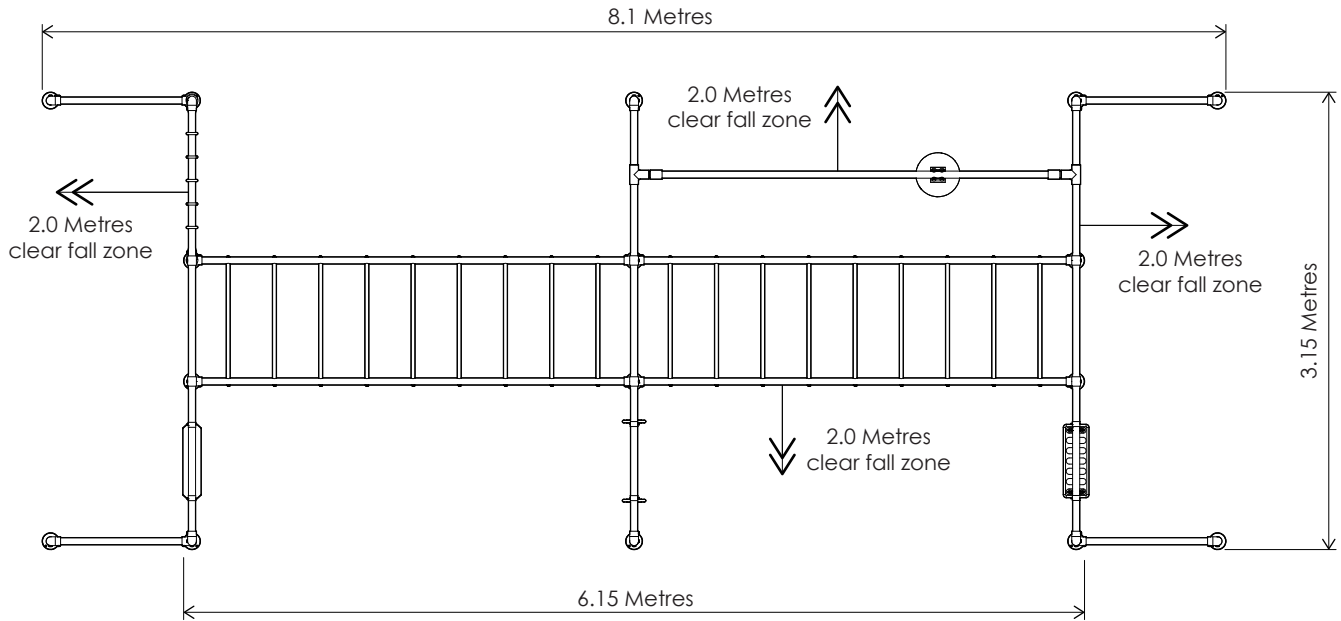

PLAN VIEW
(not to scale)

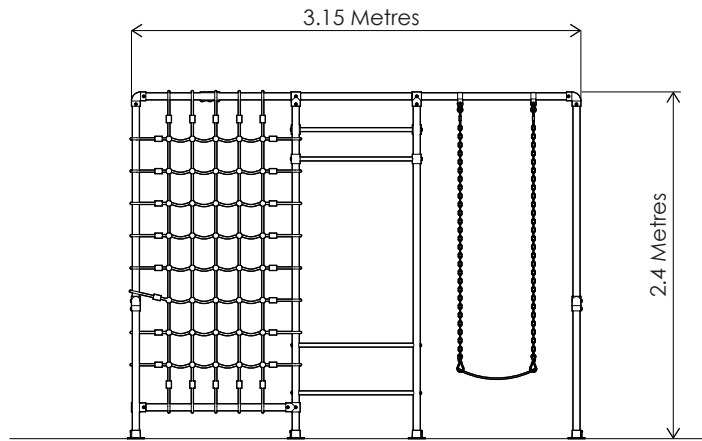

FRONT VIEW
(not to scale)

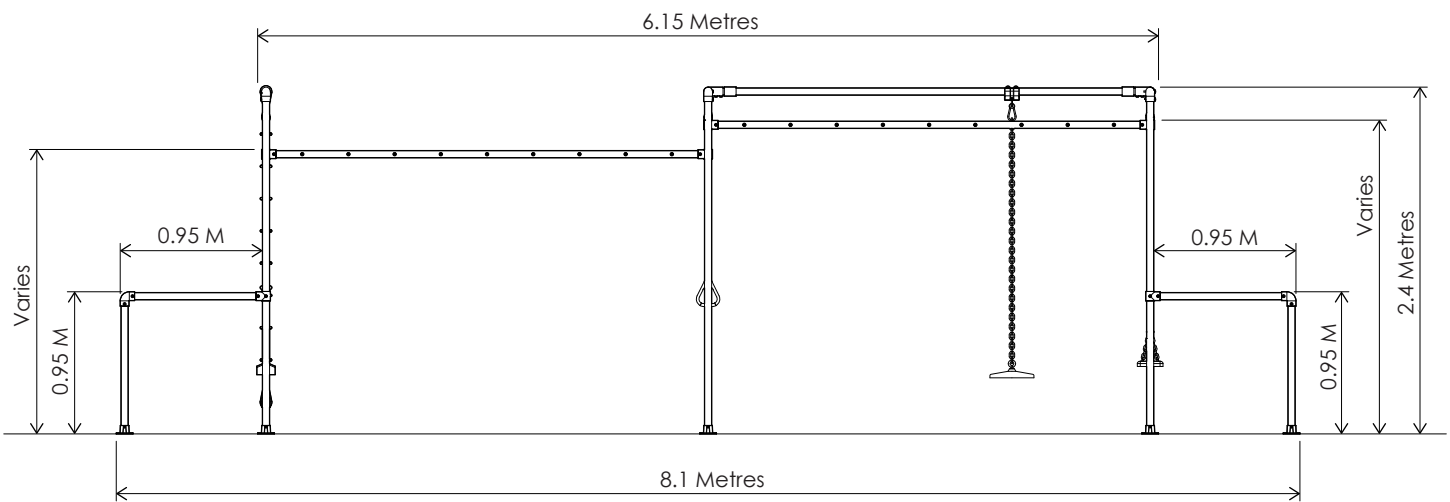

SIDE VIEW
(not to scale)

ASSEMBLY TIPS

CORRECT INSERTION INTO FITTINGS - (INDICATIVE DIAGRAM SHOWN)

All tubes must be fully inserted until contact is made with adjoining tube.

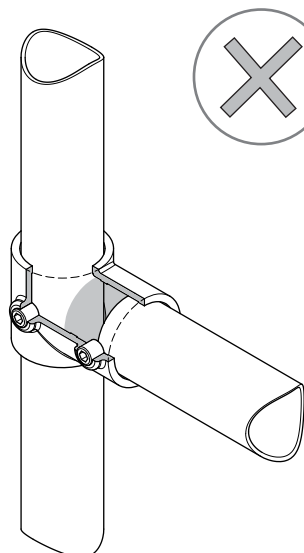

Gap.

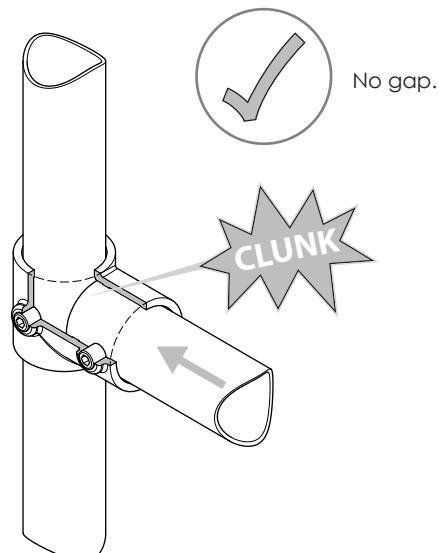

No gap.

CORRECT TIGHTENING METHOD OF GRUB SCREWS - (INDICATIVE DIAGRAM SHOWN)

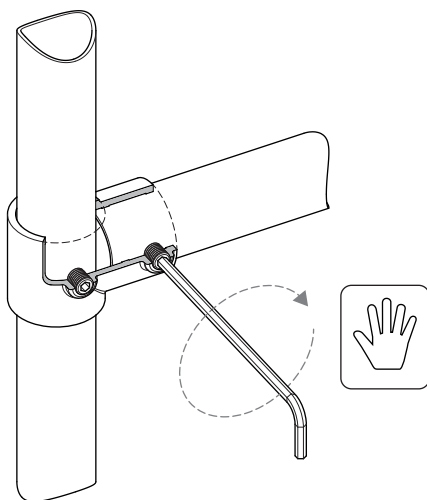

1. With long end of allen key, hand tighten grub screw as much as possible.

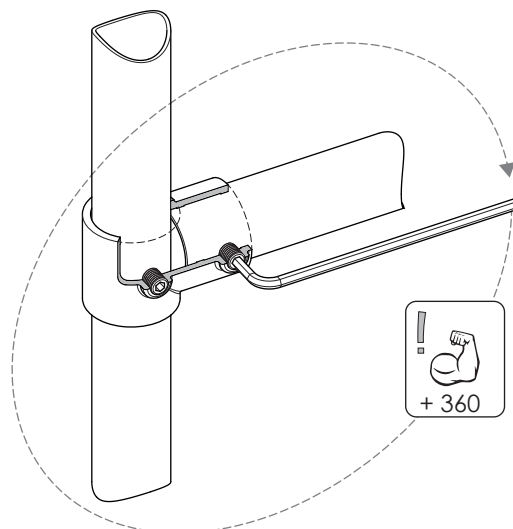

2. Using other end of the allen key do one full 360 degree turn as a minimum, use muscles!



CORRECT TIGHTENING METHOD OF RUNG BOLTS - (INDICATIVE DIAGRAM SHOWN)

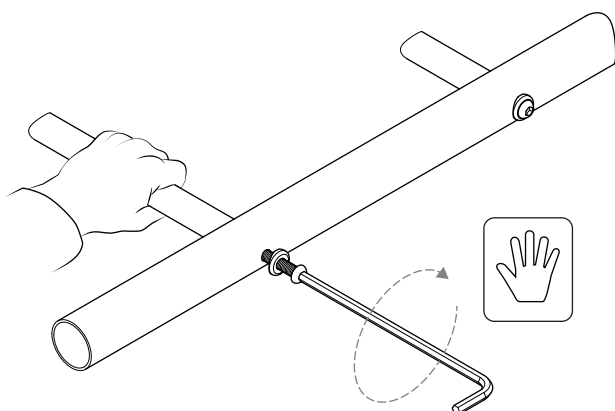

1. With long end of allen key, hand tighten bolt hard up against washer and outside of tube. Hold rung to avoid rotation.

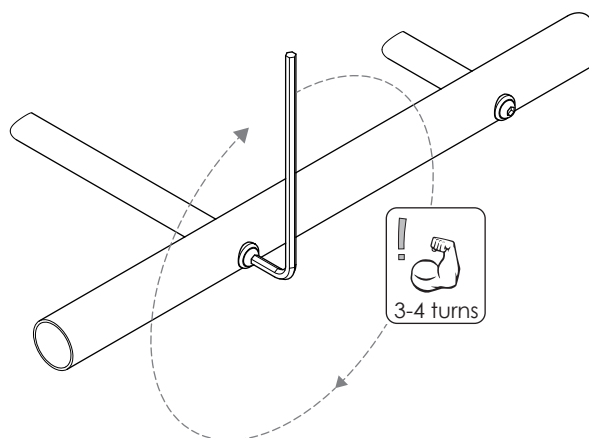

2. Using short end of the allen key fully tighten, approximately 3-4 full turns .



ASSEMBLY TIPS (CONTINUED)

IT IS CRITICAL YOUR MAIN FRAME IS 100% SQUARE AND LEVEL (INDICATIVE DIAGRAM SHOWN)

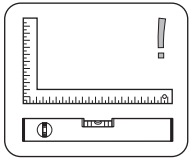

Check assembly is 100% level, square & straight.

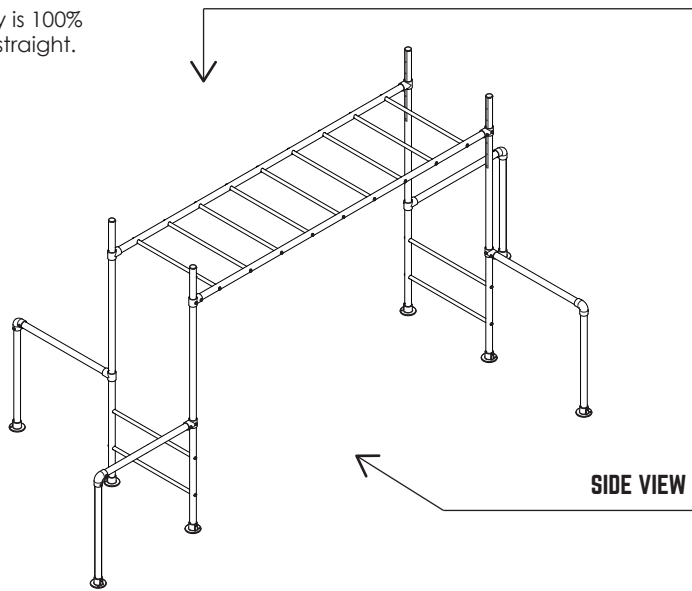

PLAN VIEW

SIDE VIEW

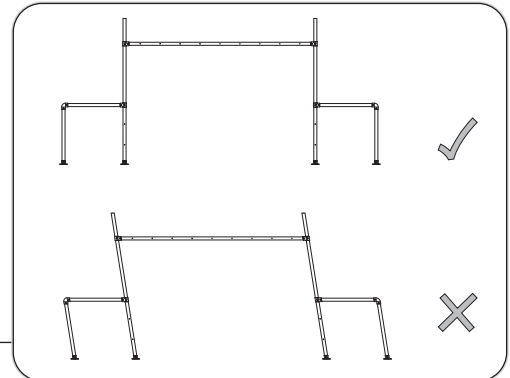
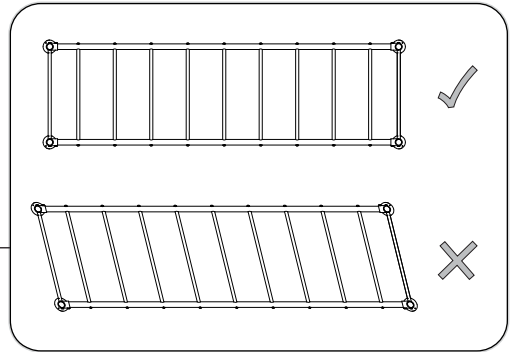

If your frame is not straight or level remove pegs, loosen grub screws, re-adjust re-tighten and re-peg the frame.

INSTALLATION ON A SLOPE

If your frame is being installed on a slope ensure the monkey ladder bar is level. Either install at different heights on the legs or dig down at one end until level.

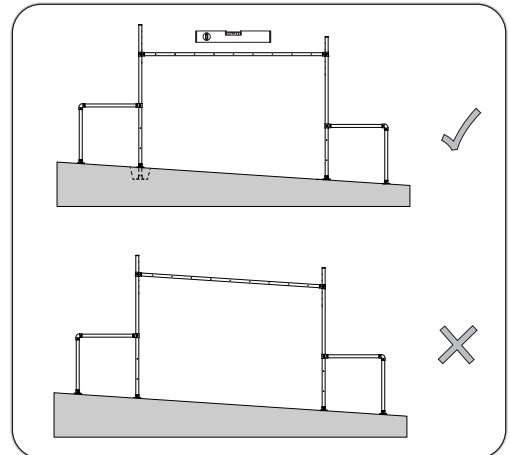

FIXING TYPICAL ORIENTATION - (INDICATIVE DRAWING SHOWN)

Unless otherwise stated all grub screws and fittings should face downwards and outwards. This will reduce weathering damage, help with assembly and ease of maintenance.

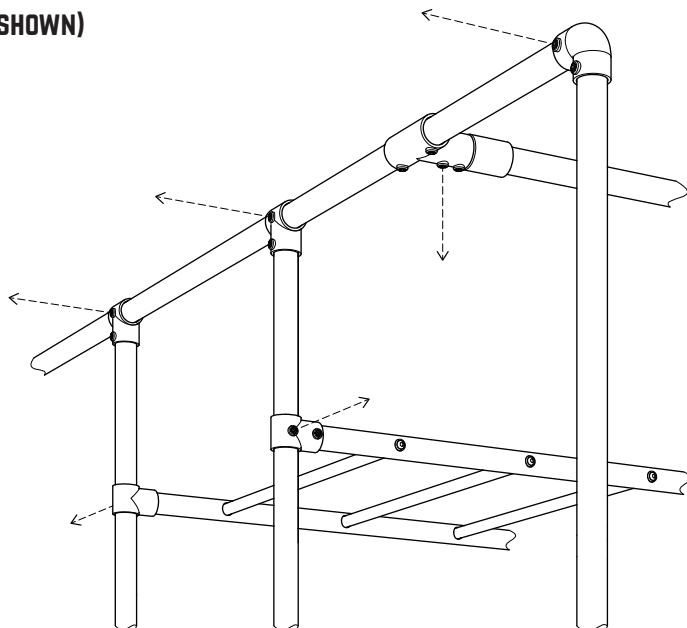

INVENTORY

TOOLS REQUIRED FOR INSTALLATION

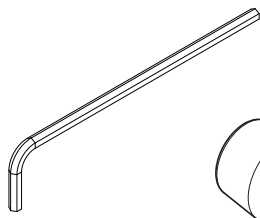

1x
8mm Allen key
(Included)

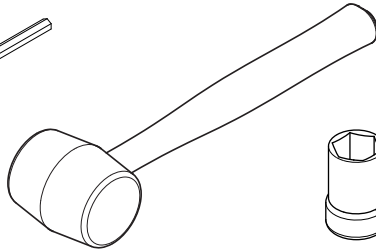

1x
Soft Hammer
(Not included)

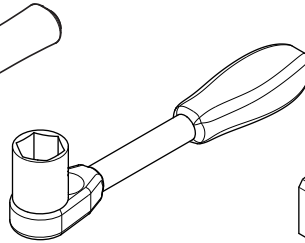

1x
17mm Ratchet
(Not included)

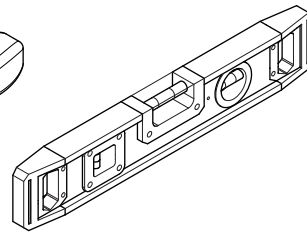

1x
Spirit Level
(Not included)

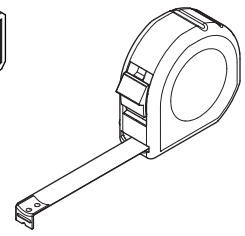

1x
Tape Measure
(Not included)

TUBES

24x
Rung Tube
25Dia. x 850mm



8x
Twirly Tube
50Dia. x 900mm



1x
Cargo Tube
50Dia. x 1040mm



6x
Swing Leg Tube
50Dia. x 2300mm

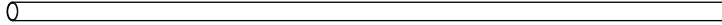

4x
Double Swing Tube/
Accessories Tube
50Dia. x 2950mm

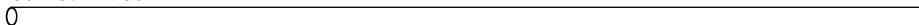

6x
Adj. Leg Tube
50Dia. x 2300mm



4x
Ladder Tube
50Dia. x 2950mm



FITTINGS

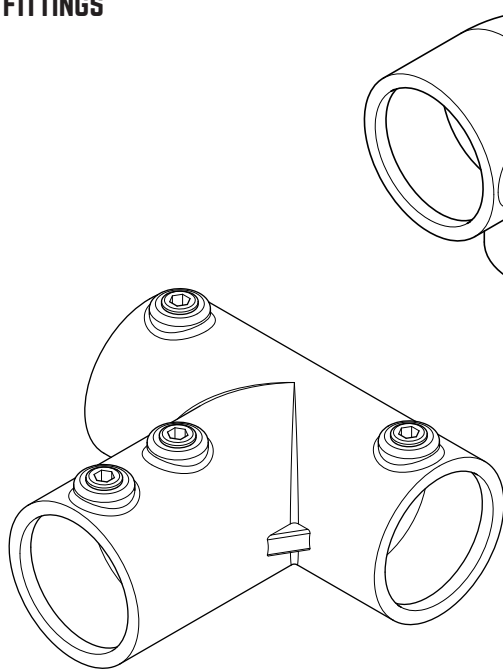

2x
Extra Long Tee
D-104L

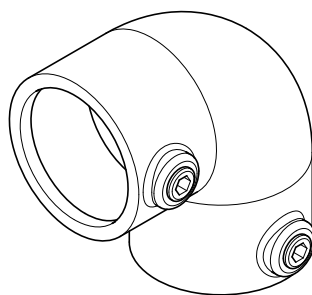

10x
Elbow
D-125

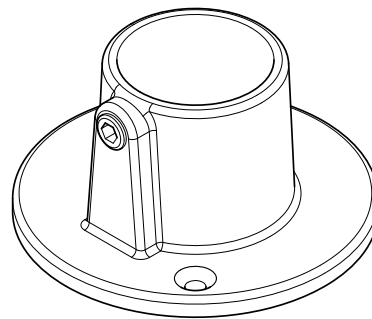

16x
Base Plate
D-131

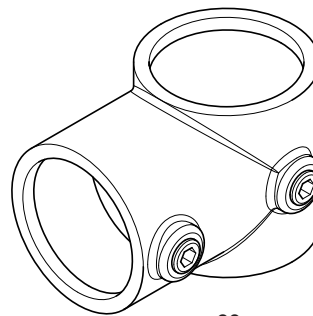

20x
Short Tee
D-101



16x
Peg

INVENTORY (CONTINUED)

HARDWARE

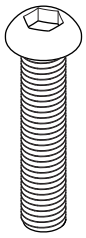

54x
M10 Bolt

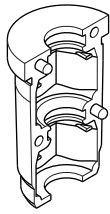

108x
Rung Insert

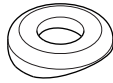

54x
Washer



108x
M10 Hex Nut

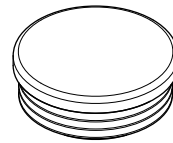

6x
Plastic End Cap



1x
Manufacture Sticker

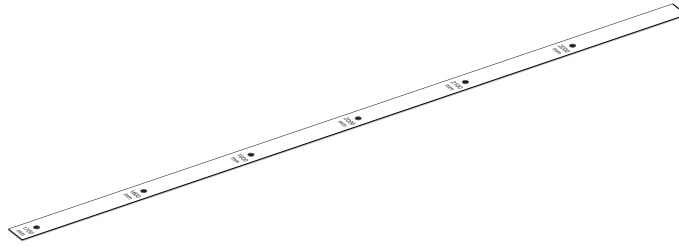

6x
Height Sticker

COMPONENTS (ACCESSORIES IF APPLICABLE)

6x
Swing Hooks



1x
Trolley

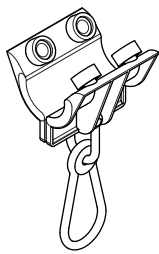

2x
Rubber Stop

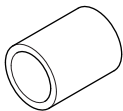

1x
Trapeze

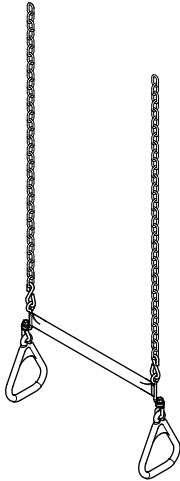

1x
Sling swing

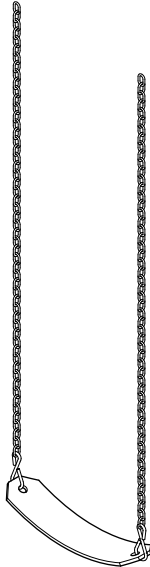

1x
Rubber Swing

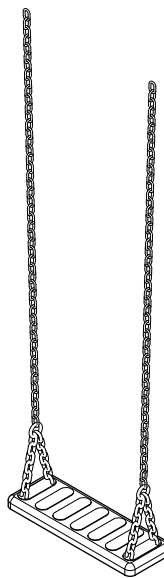

1x
Button swing

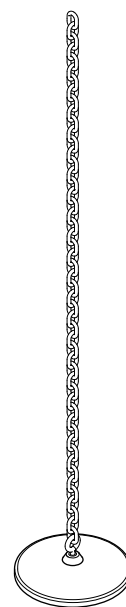

1x
Cargo Net

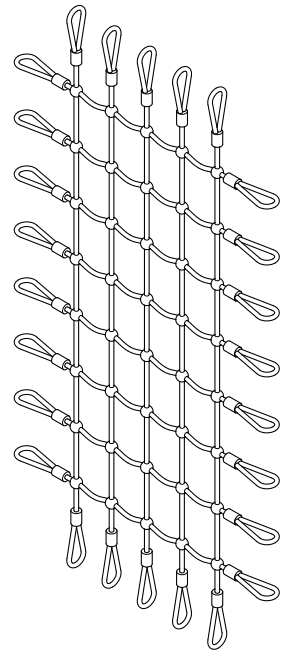

NOTE: Components not to scale.

One of the best things about a Funky Monkey Bar is the ability to add new equipment and accessories as your child and family grows. You can swap or add accessories to your existing frame, or add extra frames that will give you more versatility to attach equipment. Check out what we've got in store now at...

WWW.FUNKYMONKEYBARS.COM

ASSEMBLY INSTRUCTIONS - LADDER BAR ASSEMBLY

1 RUNG ASSEMBLY (x24)

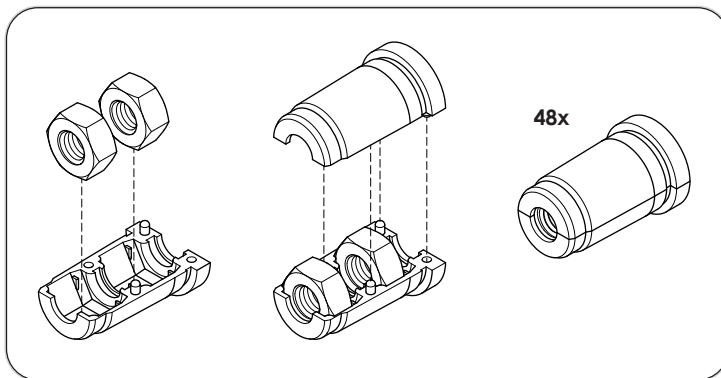

1. Assemble plastic rung inserts as shown above.

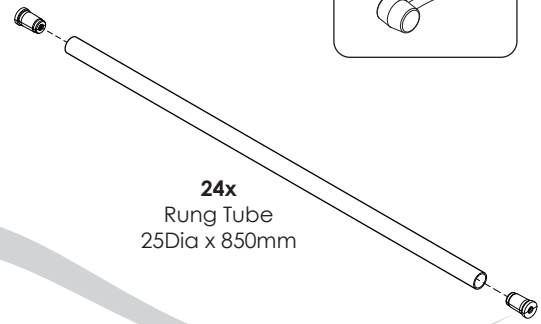

2. Push inserts into both ends of all rungs.

2 MONKEY BAR LADDER ASSEMBLY

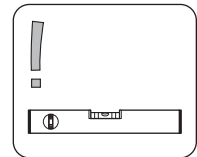
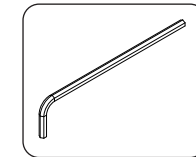
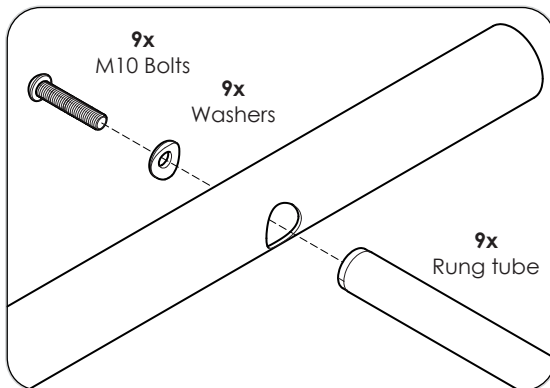

Hand tighten all bolts.

Assemble on flat surface.

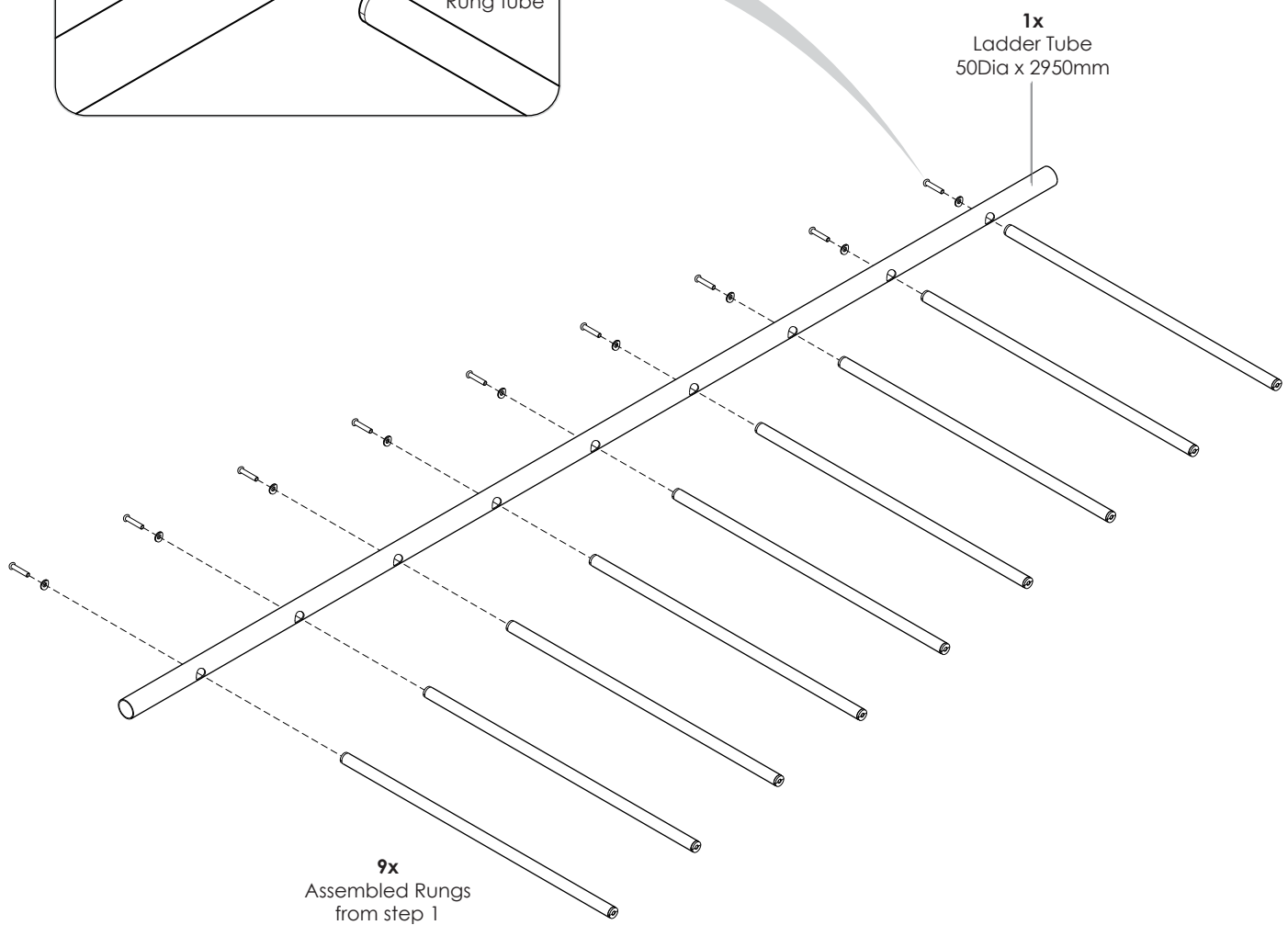

9x
Assembled Rungs
from step 1

3 ATTACH SECOND LADDER TUBE

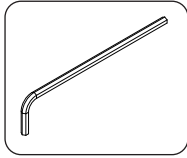

Hand tighten all bolts

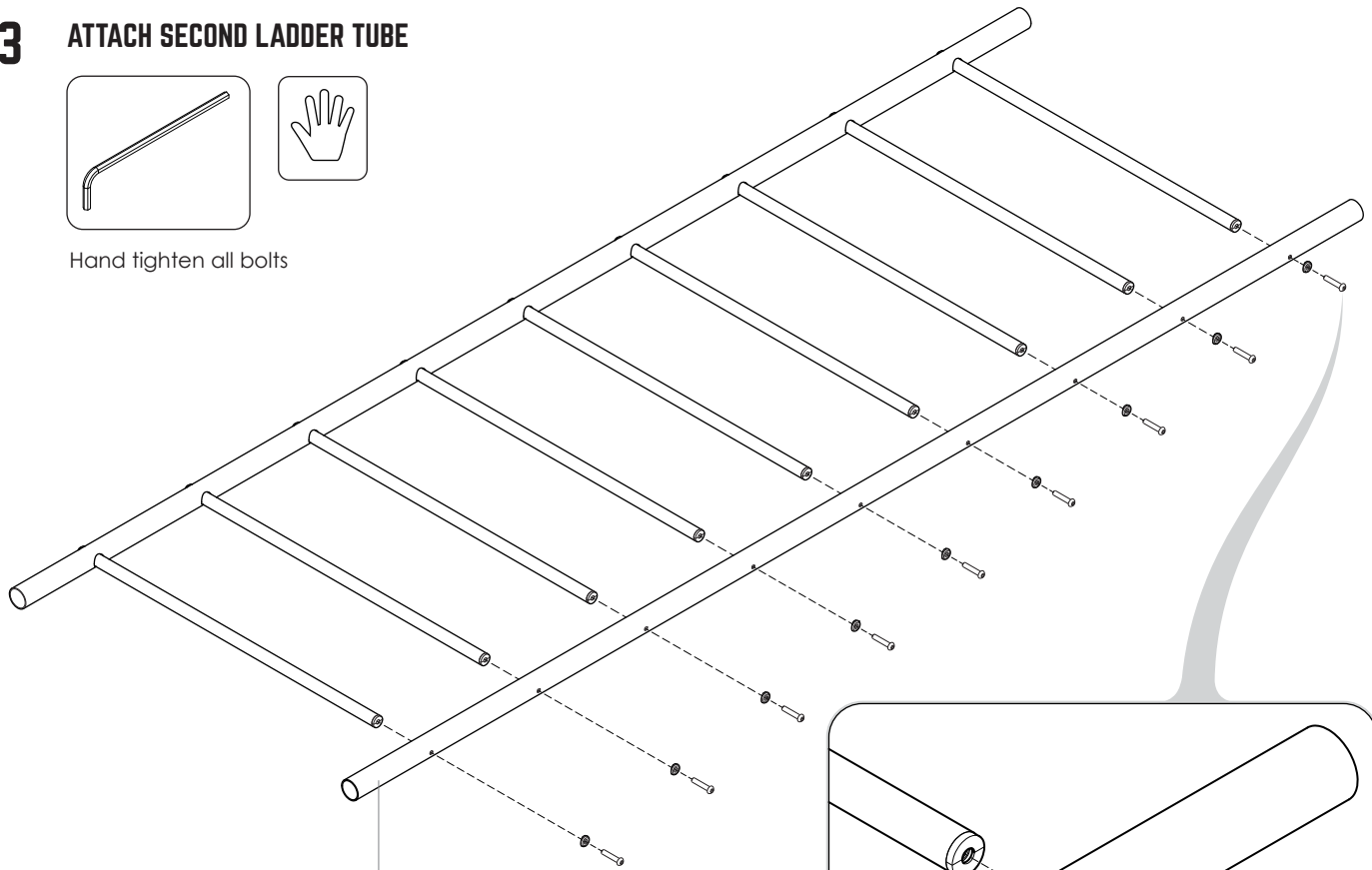

1x
Ladder Tube
50Dia x 2950mm

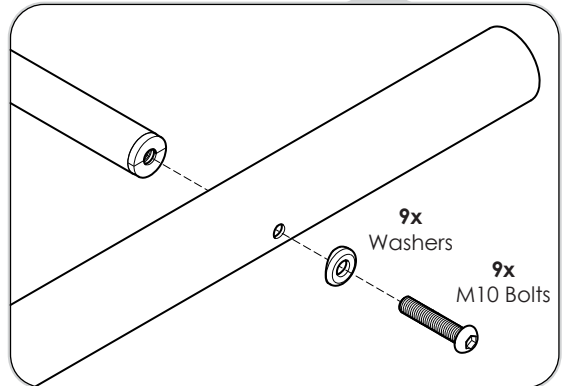

4 FIRMLY TIGHTEN ALL RUNG BOLTS.

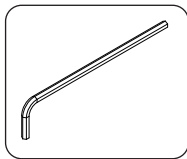

See page 5 for correct tightening method.

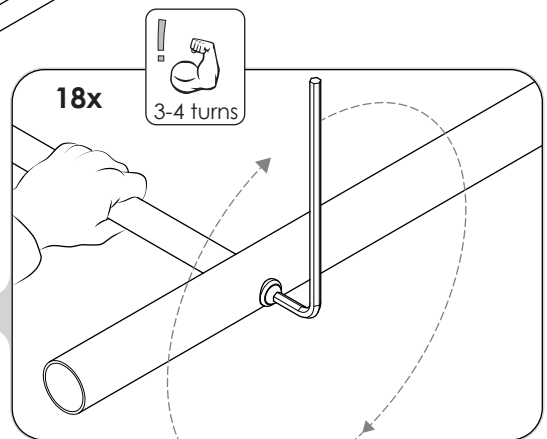
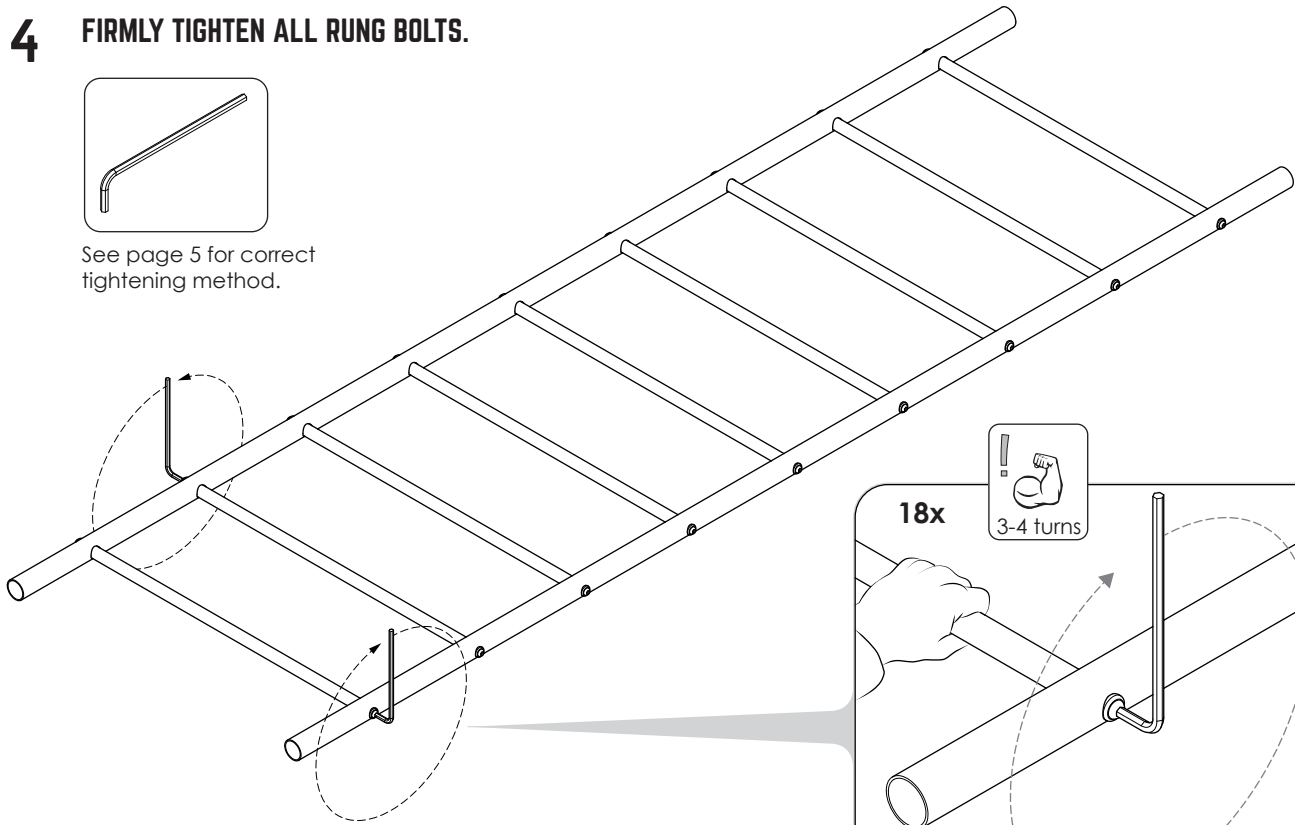

5 REPEAT STEPS 2 - 4 FOR 1X MORE LADDER BAR ASSEMBLY.

6 LADDER BAR ASSEMBLY X2.

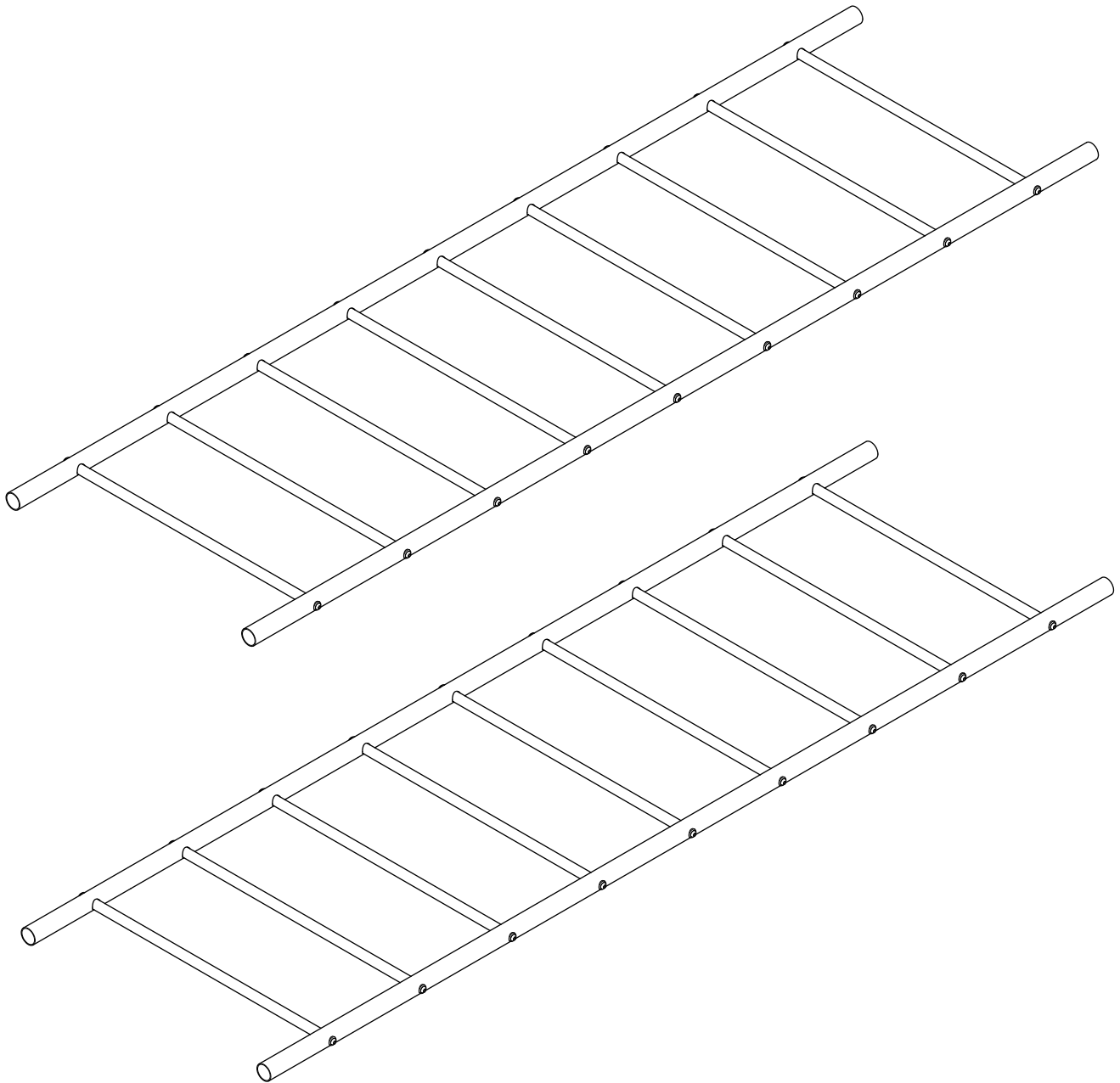

ASSEMBLY INSTRUCTIONS - LEG ASSEMBLY

7 LEG ASSEMBLY x3

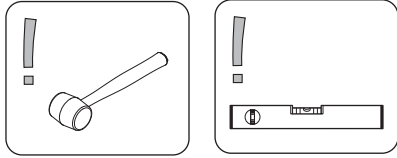

Insert plastic end caps into leg tubes.

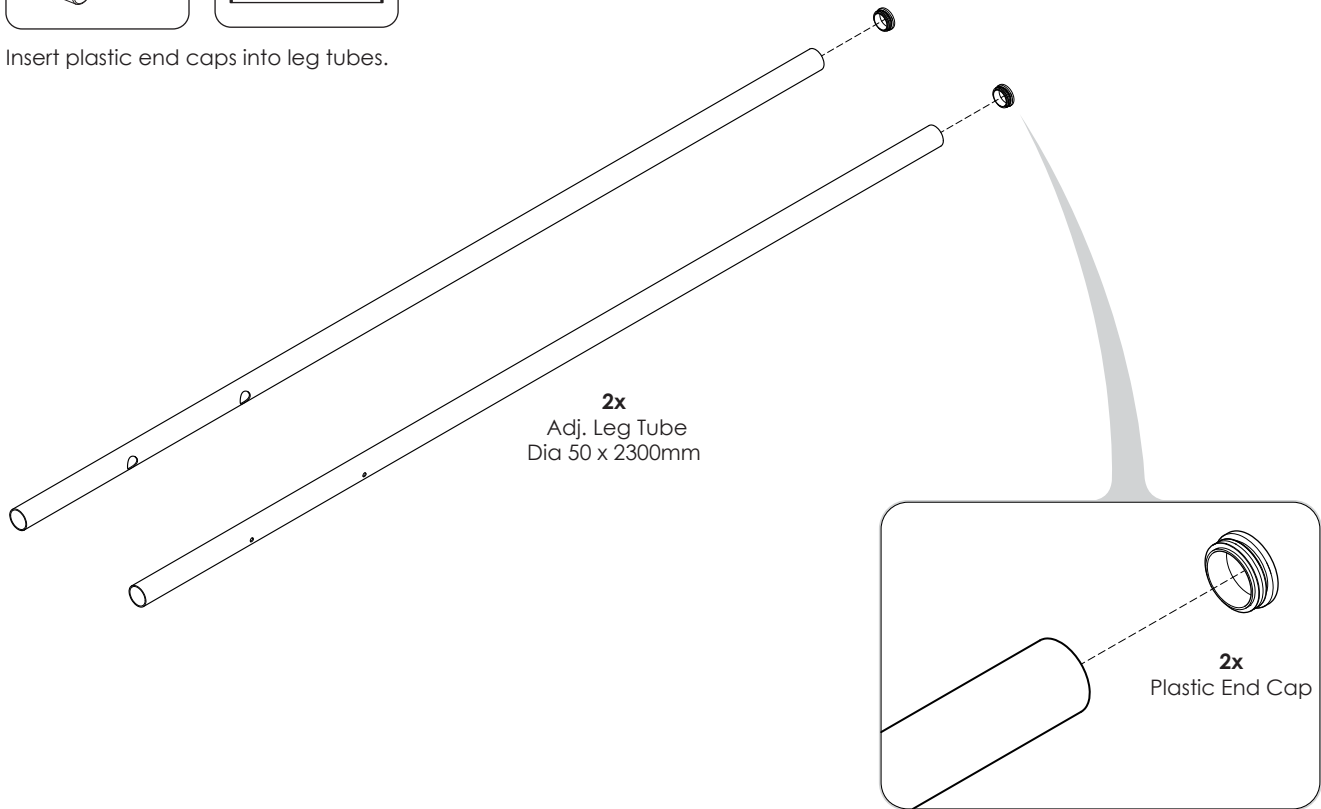

8 INSERT RUNGS

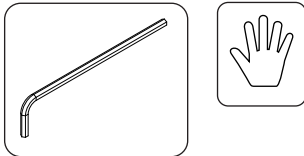

Hand tighten all bolts.

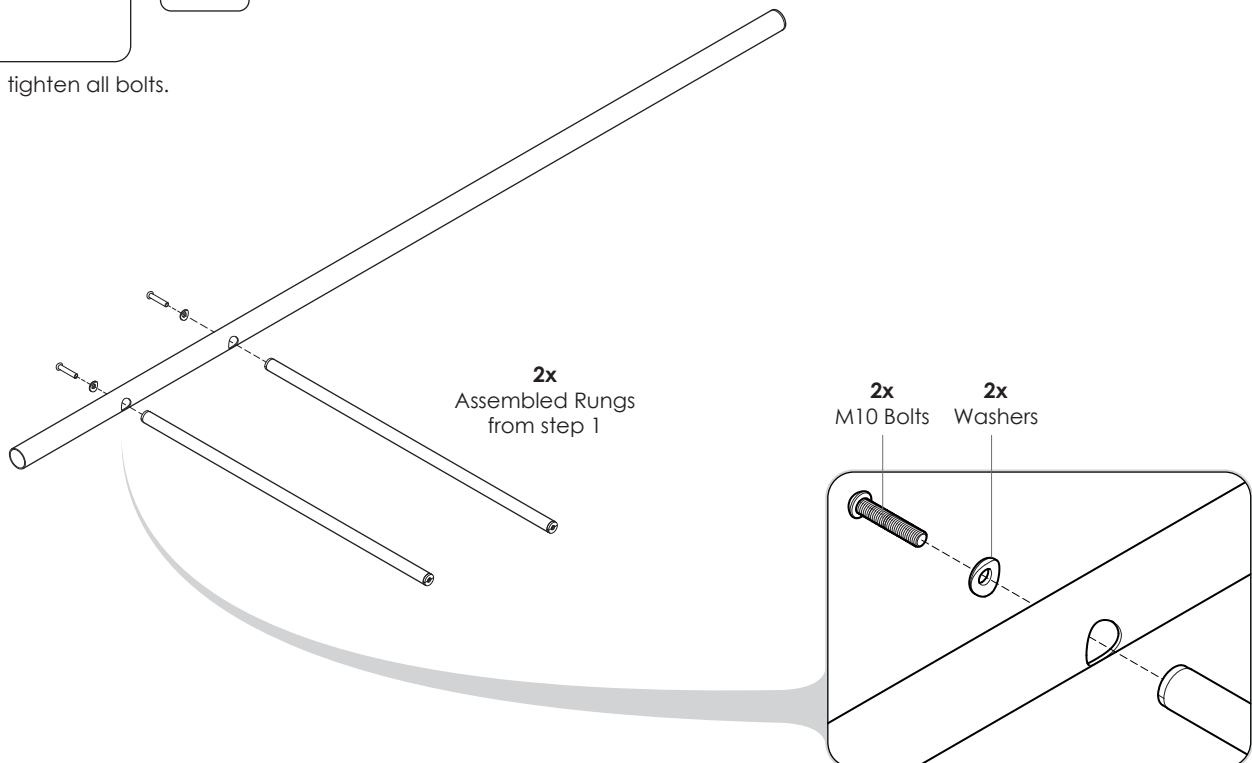

9 ATTACH SECOND LEG AND CARGO NET

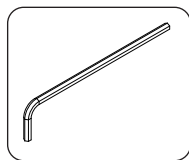

Hand tighten all bolts.



1. Slide cargo net onto second leg tube.

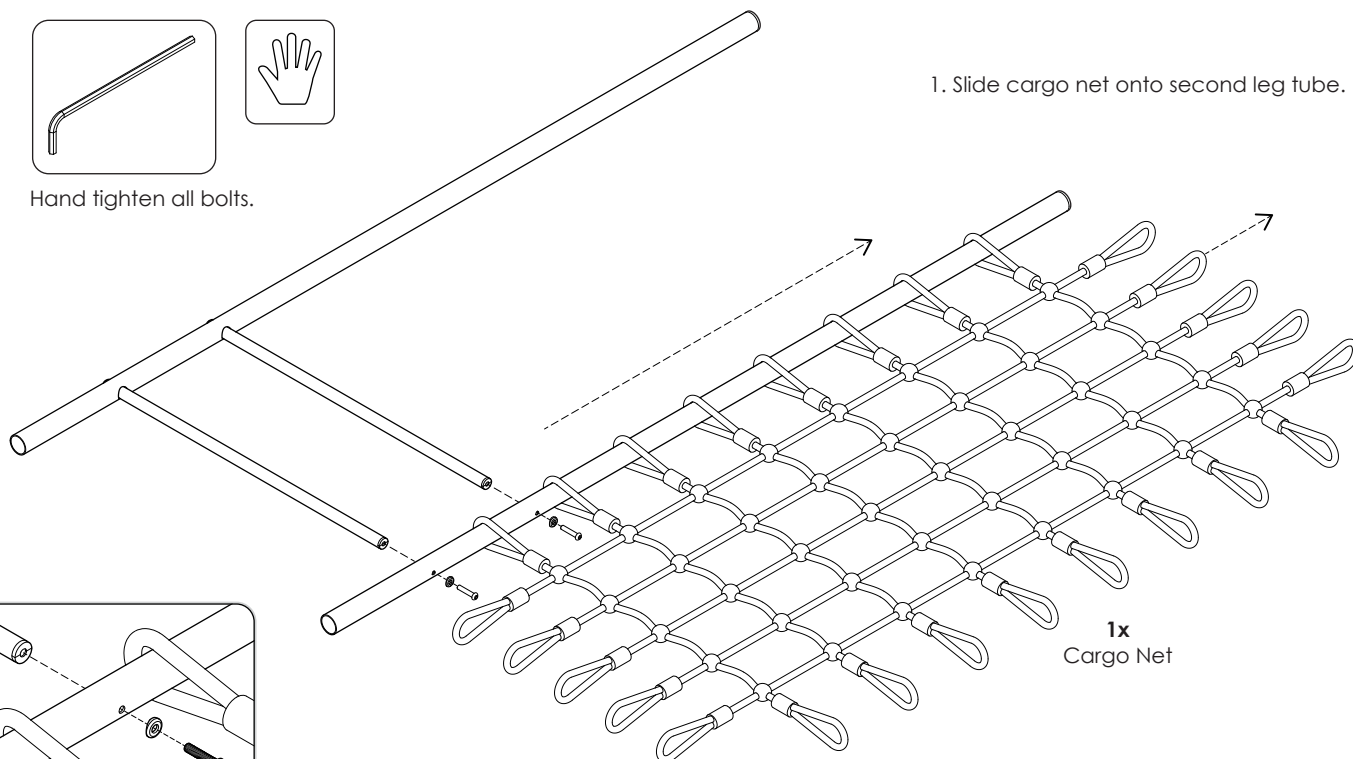

1x
Cargo Net

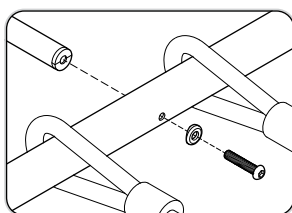

2. Ensure one or two hoops are between the rungs. Bolt leg to rungs.

10 ATTACH BASE PLATES AND 1x SHORT TEE (A) (CARGO NET SIDE)

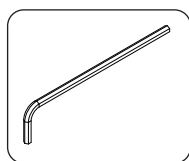

Tighten all grub screws on base plates.

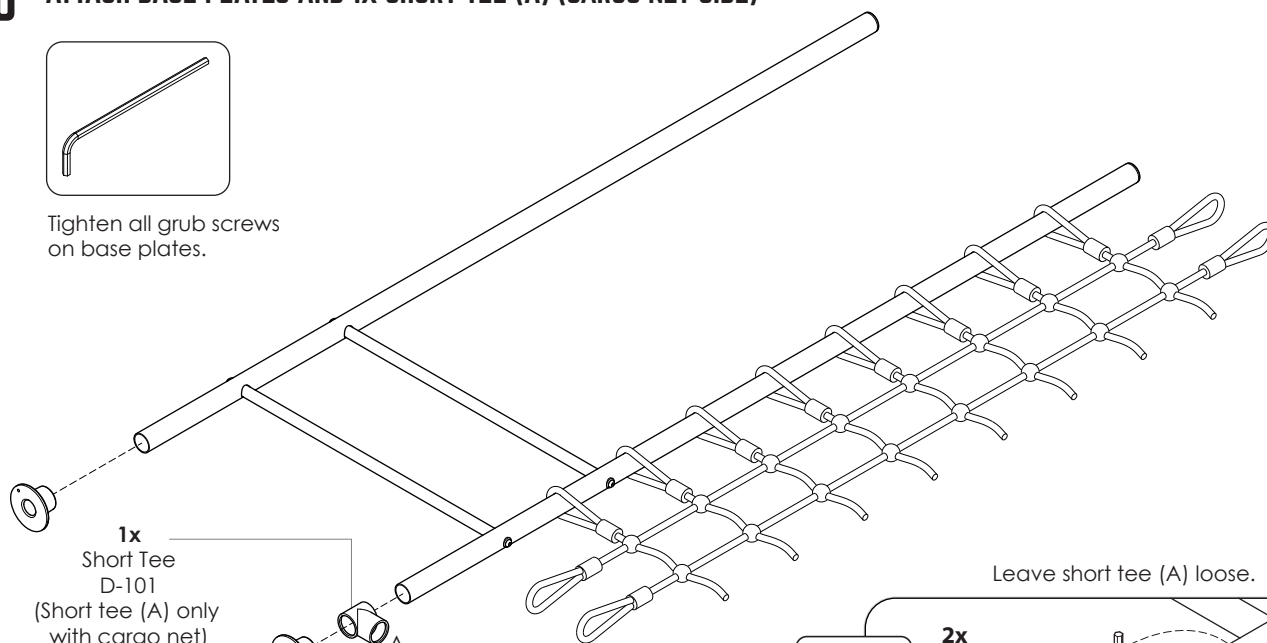

1x
Short Tee
D-101
(Short tee (A) only
with cargo net)

2x
Base Plate
D-125

Leave short tee (A) loose.

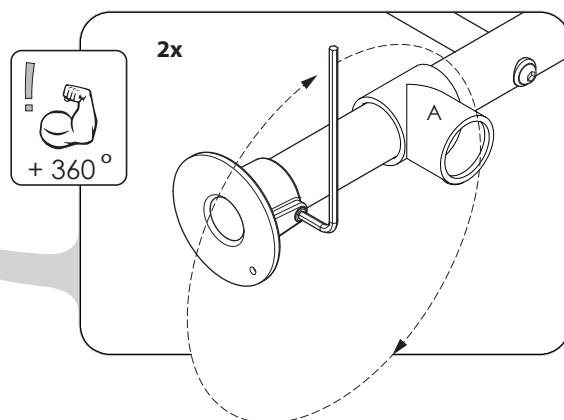

2x
+ 360°

11 APPLY HEIGHT STICKERS

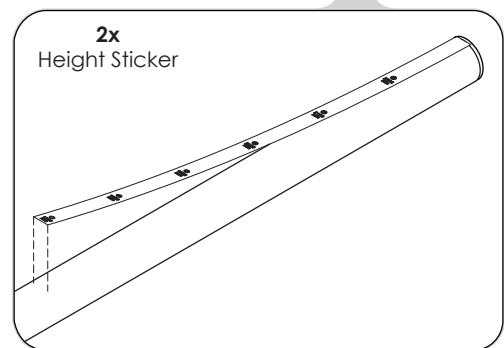
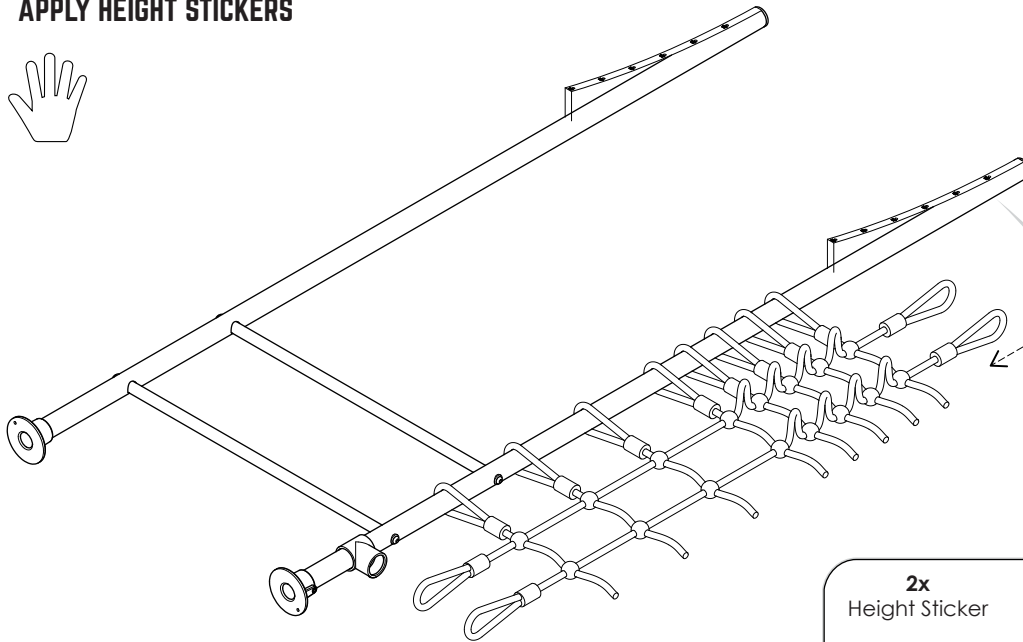

Move net downwards to allow height sticker application.

12 SET LADDER BAR HEIGHT.

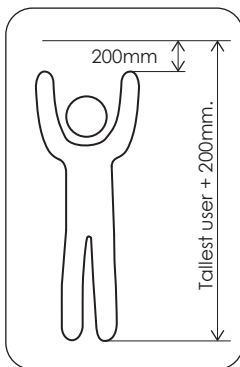

Good starting height is 100-200mm above reach.

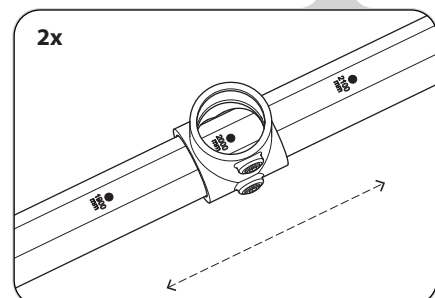
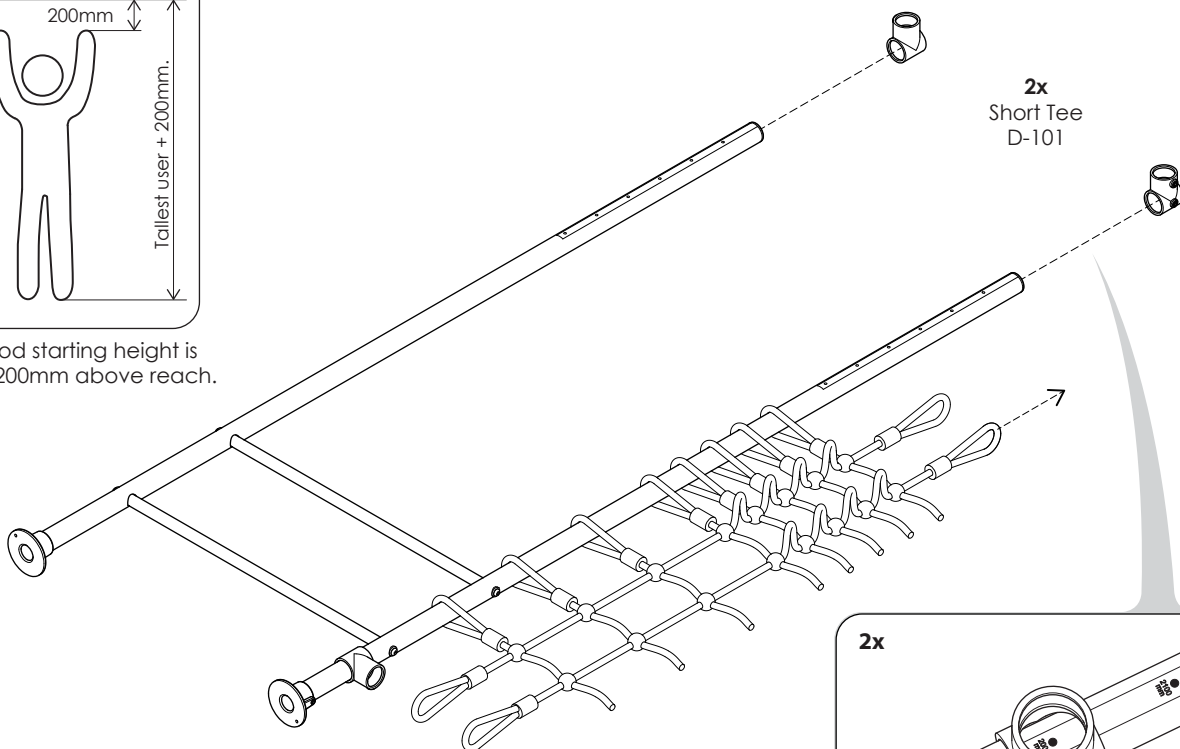

Position top short-tee at measured height.
Push through cargo hoops if required.

13 FIRMLY TIGHTEN ALL GRUB SCREWS AND RUNG BOLTS.

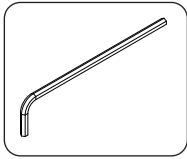

Hand tighten grub screw A. (Temporary location). Fully tighten all others.

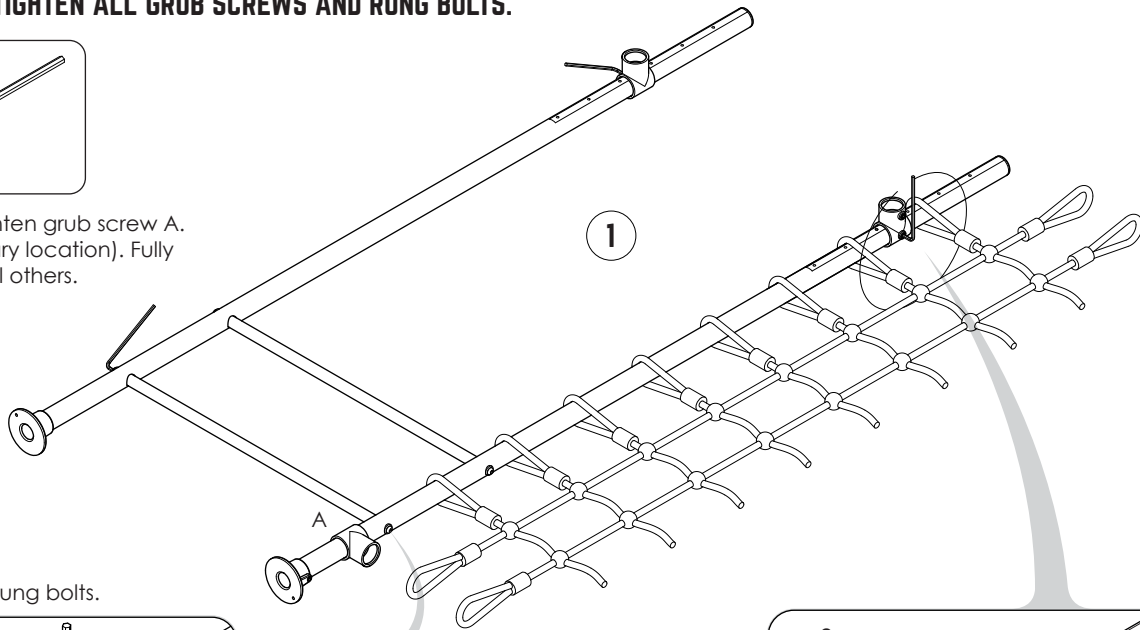

Fully Tighten rung bolts.

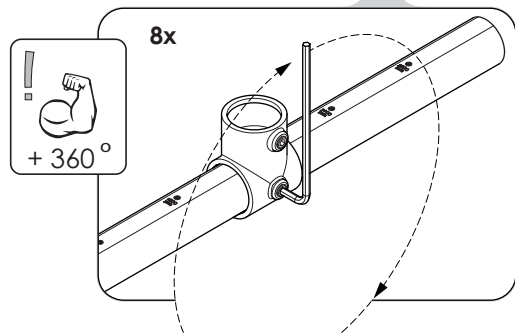
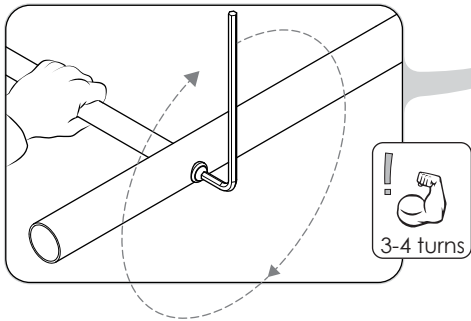

14 REPEAT STEPS 7-13 FOR 2X MORE LEG ASSEMBLIES. SAME PROCEDURE BUT WITHOUT CARGO NET AND ADDITIONAL SHORT TEE (A). DIFFERENT SHORT TEE ARRANGEMENT AT TOP- (SEE STEP 15 FOR FINAL RESULT)

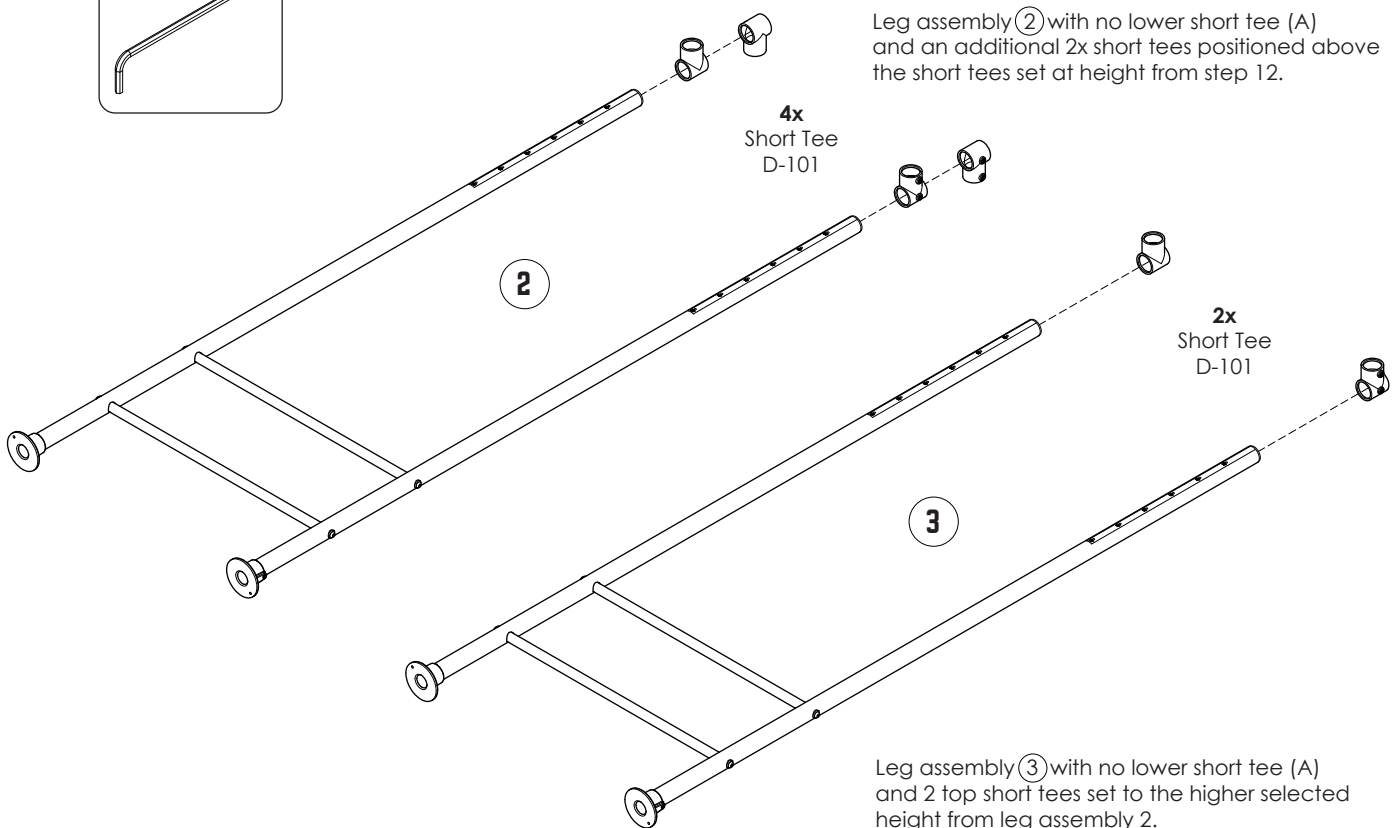
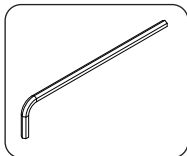

Leg assembly ② with no lower short tee (A) and an additional 2x short tees positioned above the short tees set at height from step 12.

Leg assembly ③ with no lower short tee (A) and 2 top short tees set to the higher selected height from leg assembly 2.

15 LEG ASSEMBLY X 3.

Standing up with top tees facing each other.
Check all grub screws are fully tightened
except on fitting A (hand tight only).

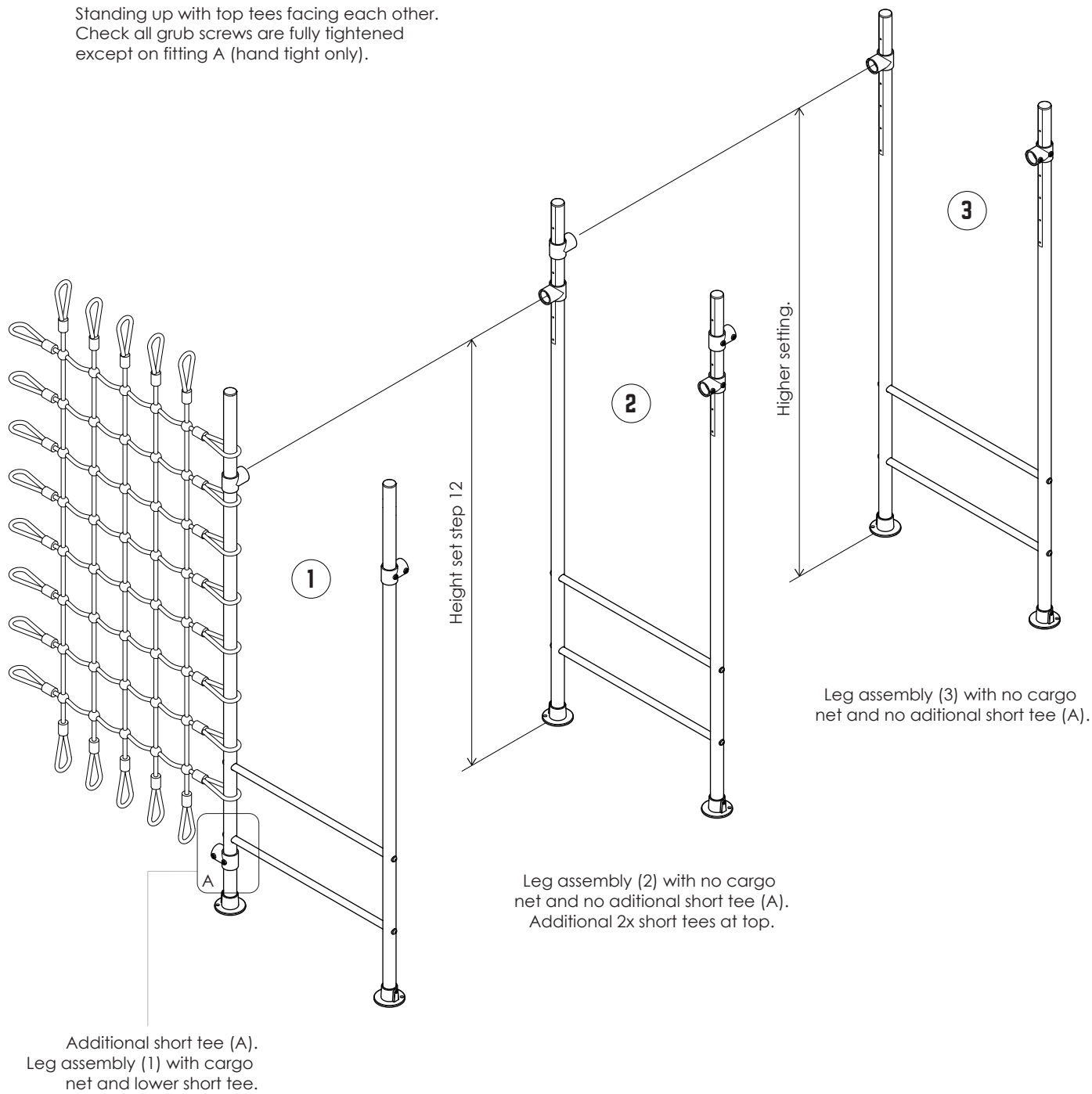

16 CHECK ALL FITTING GRUB SCREWS AND RUNG BOLTS ARE FULLY TIGHTENED

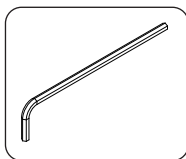

Firmly tighten all grub screws and bolts,
Leave short tee A loose.

ASSEMBLY INSTRUCTIONS - TWIRLY WHIRLY BAR ASSEMBLY

17 ASSEMBLE VERTICAL TWIRLY TUBE

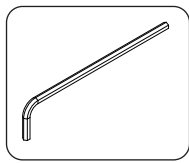

Tighten all grub screws.

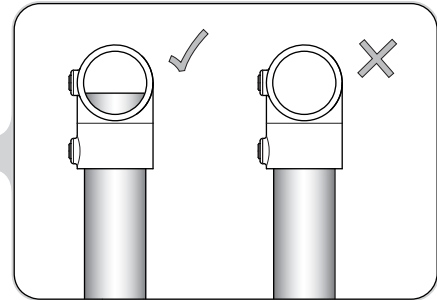
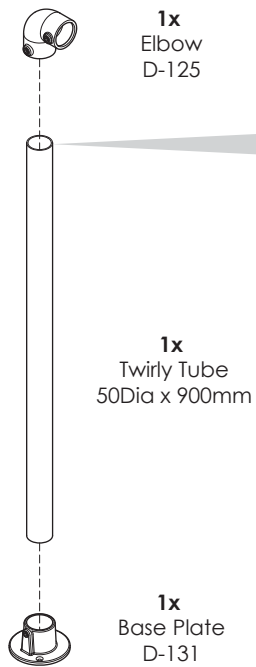

Insert Twirly Tube fully into Elbow.

18 ATTACH HORIZONTAL TWIRLY TUBE

Fully insert twirly tube then firmly tighten all grub screws.

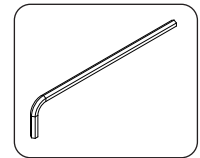
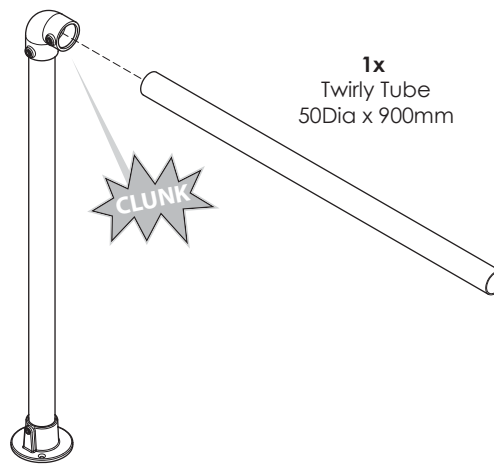
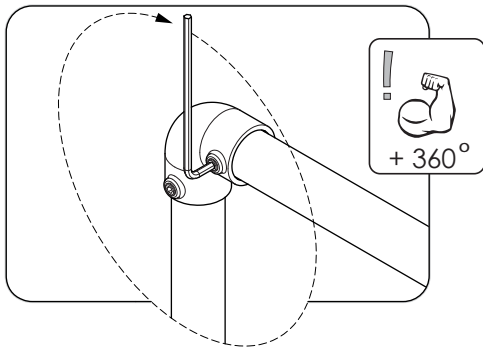

19 REPEAT STEPS 17 - 18 FOR 3 MORE TWIRLY WHIRLY BARS.

20 TWIRLY WHIRLY BAR x4

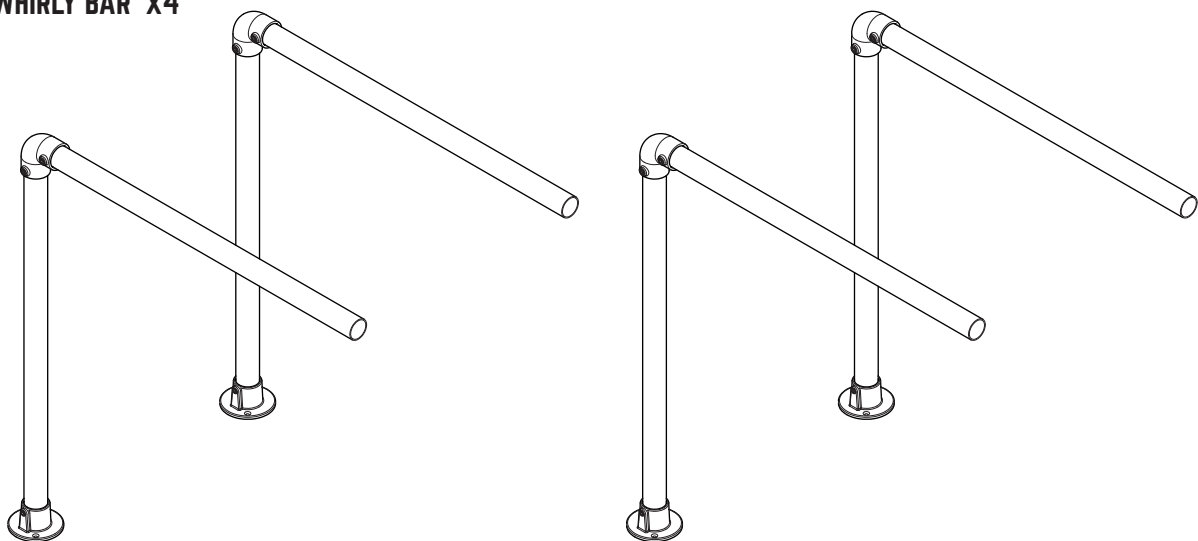

ASSEMBLY INSTRUCTIONS - MAIN MONKEY BAR ASSEMBLY

21 FLIP LEGS 1 & 2 OVER

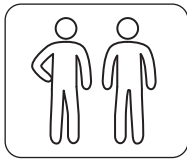

For the following step the legs should be flipped over & attached one at a time.

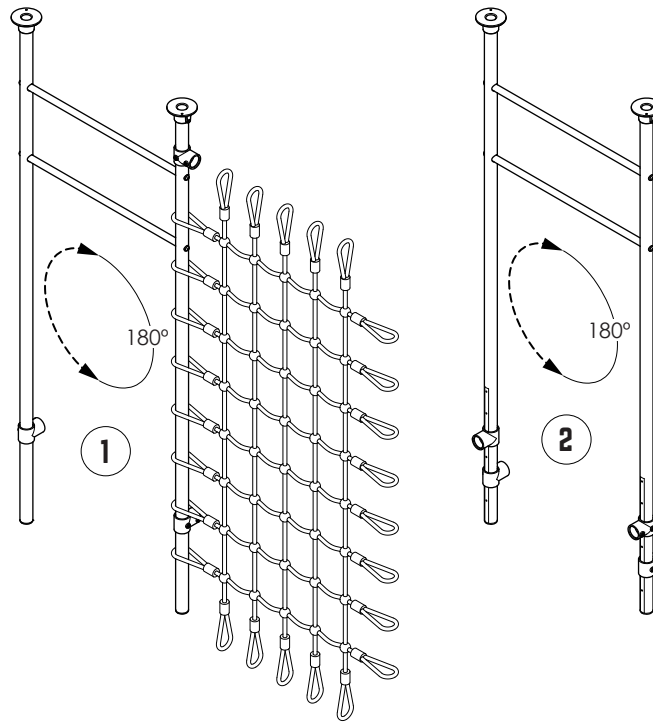

22 ATTACH 2X LEGS TO LADDER

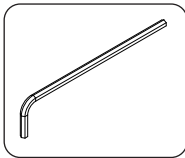

1. Attach first set of legs ① - tighten all grub screws.
2. Attach second set of legs ② - tighten all grub screws.

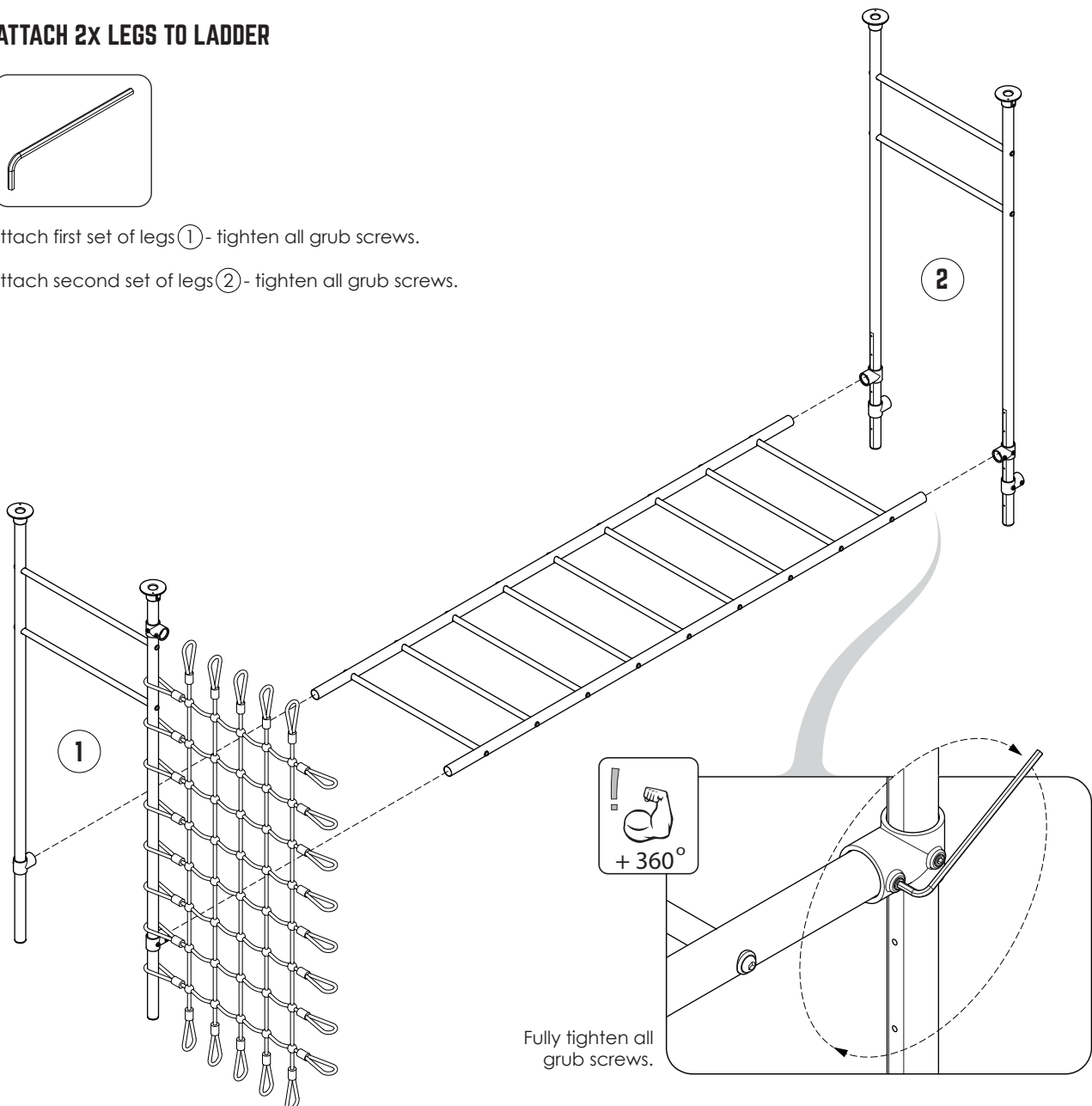

23 FLIP ASSEMBLY OVER

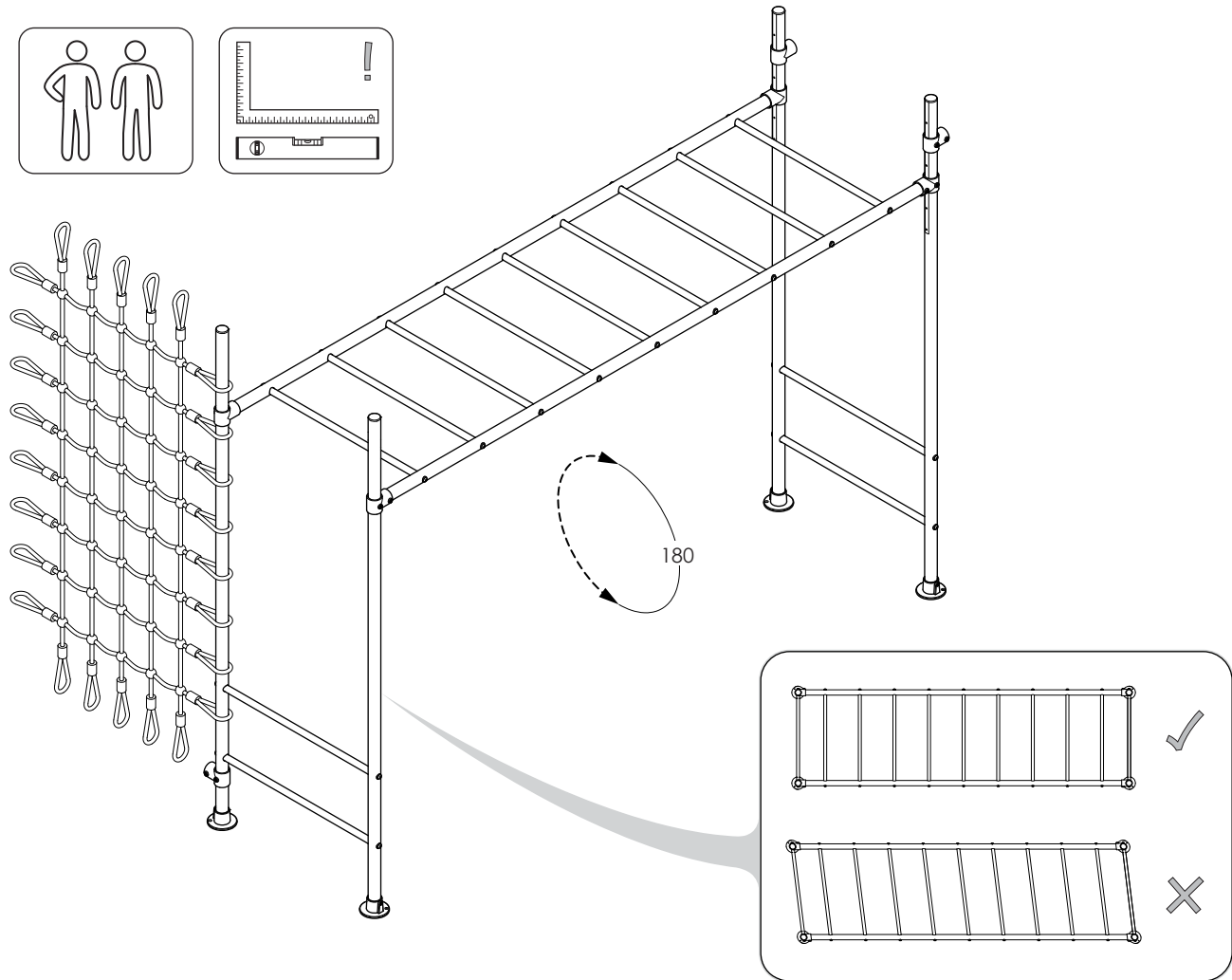
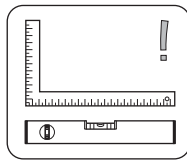
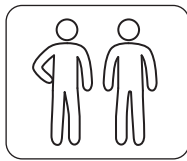

**CRITICAL : ENSURE YOUR FRAME IS 100% SQUARE AND LEVEL (AS PER PAGE 6)
BEFORE MOVING ONTO THE REST OF THE ASSEMBLY**

24 SECURE TO GROUND

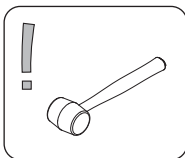

Select suitable location.
Hammer in pegs x4.

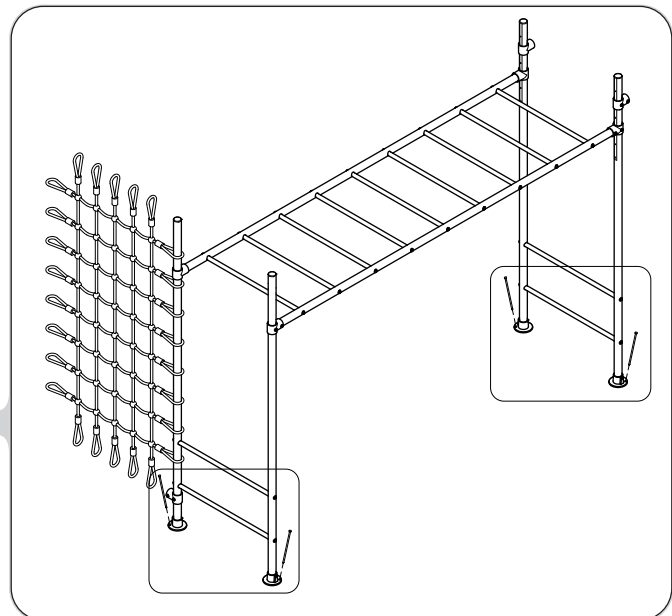
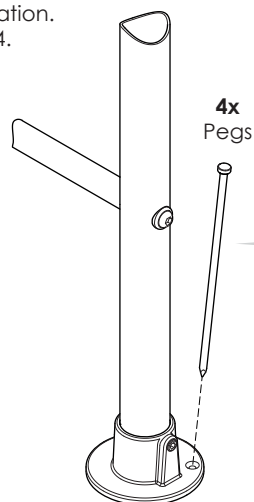

25 ATTACH 1x LEGS TO LADDER

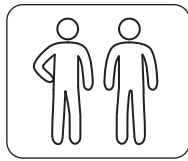
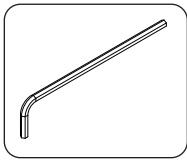

1. Flip Legs ③ over from step 15.
2. Attach second ladder to short tees.
3. Fully tighten all grub screws.

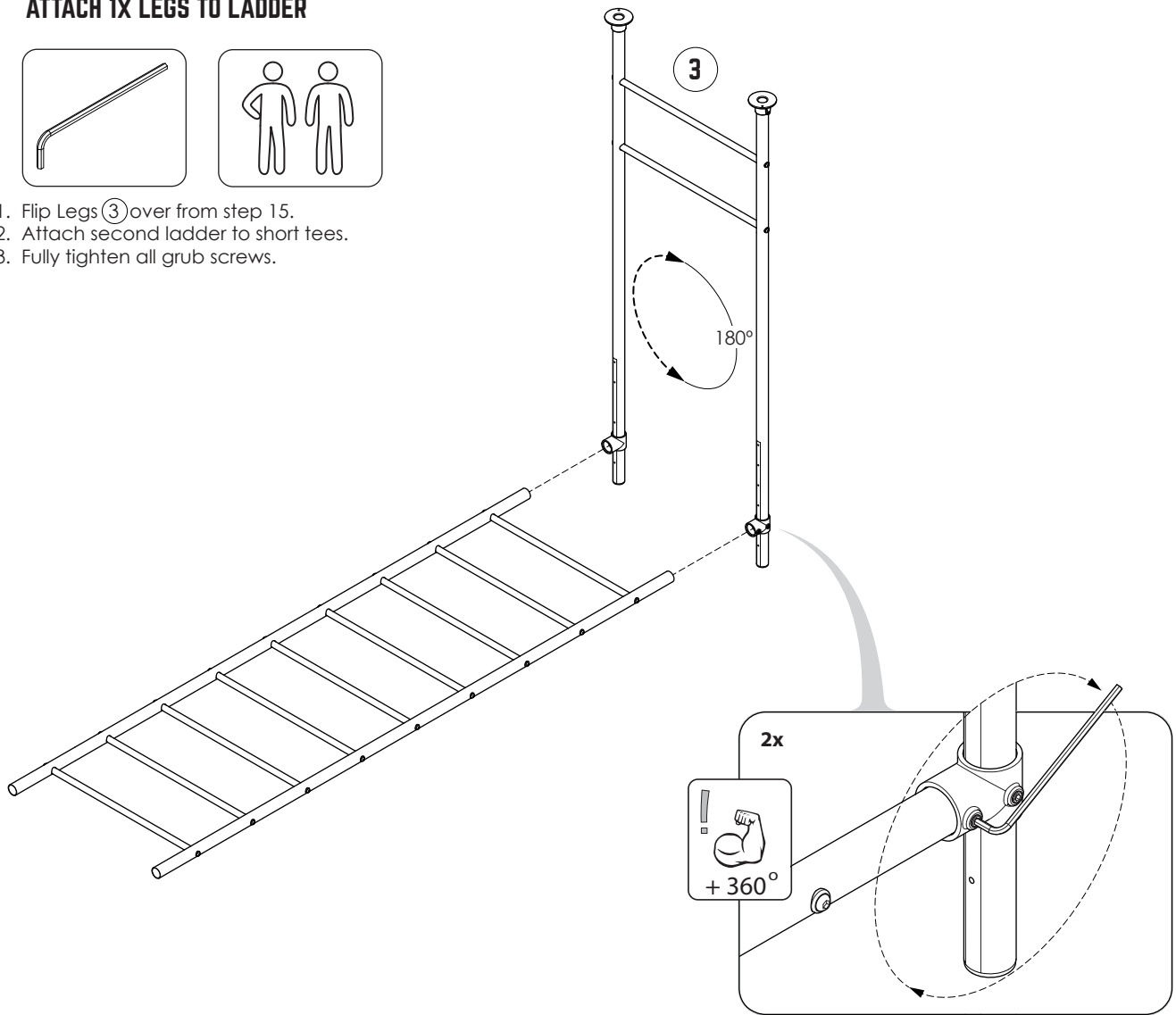

26 FLIP ASSEMBLY OVER

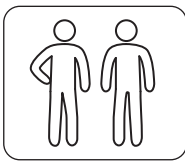

With two people flip assembly over to the upright position.

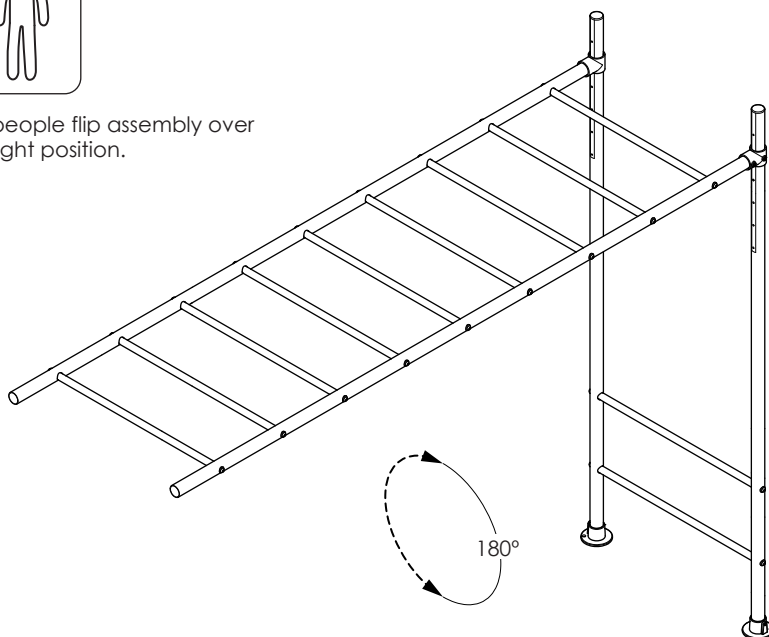

27 ATTACH SECOND MAIN MONKEY BAR ASSEMBLY

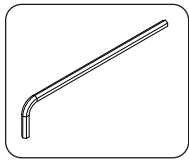

Attach the new assembly to the existing pegged down main monkey frame.

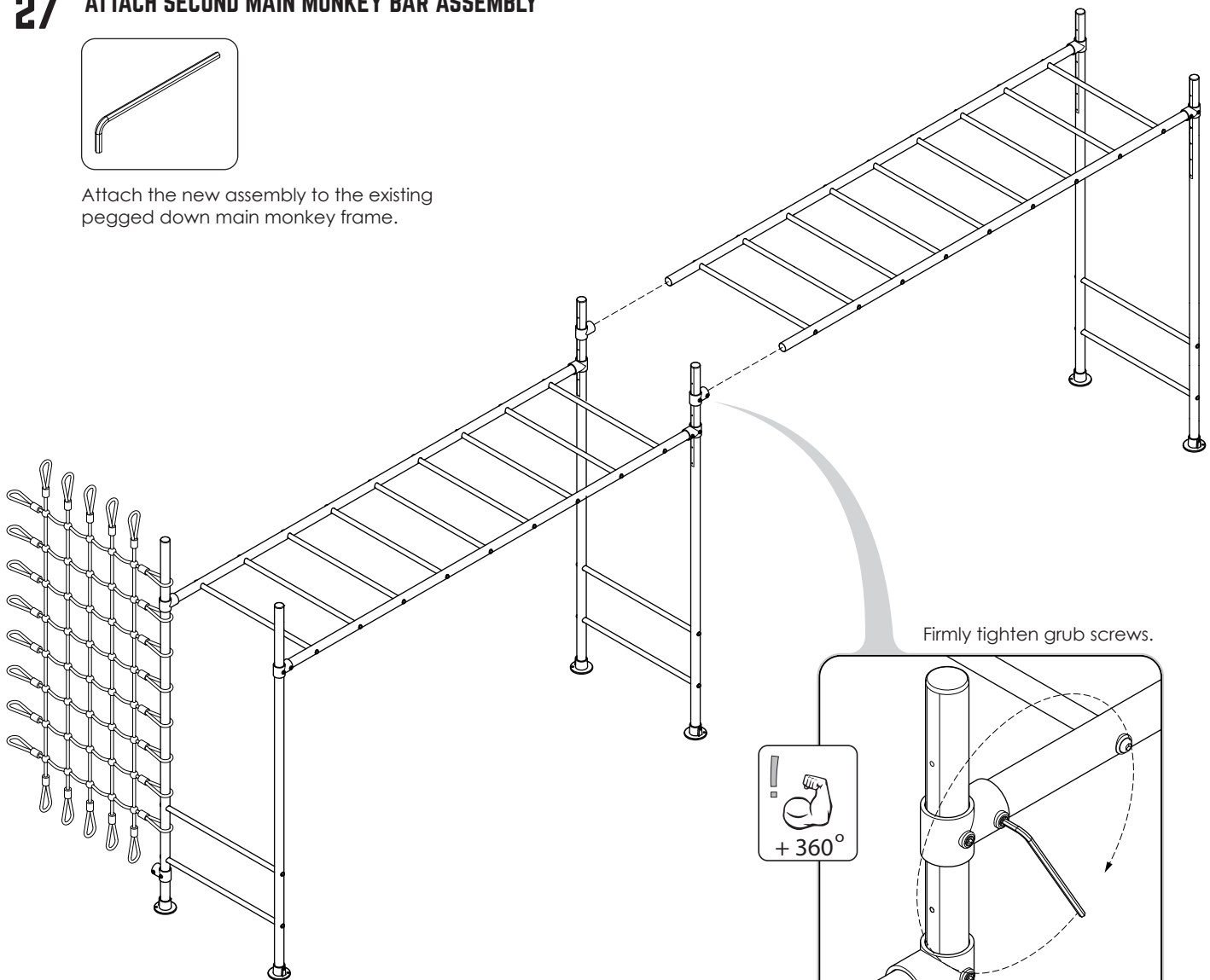

Firmly tighten grub screws.

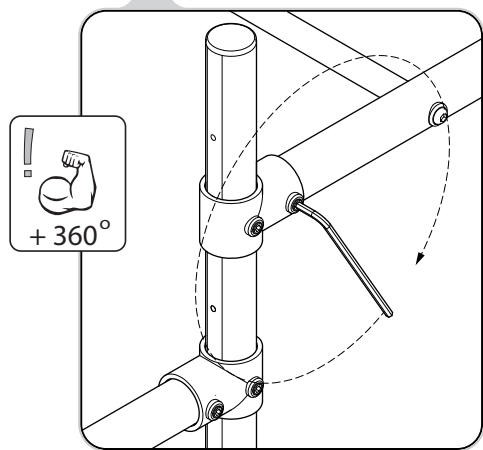

28 SECURE TO GROUND

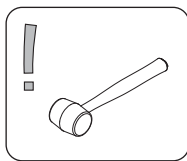
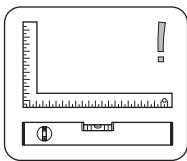

1. Check level and square.
2. Hammer in pegs x2.

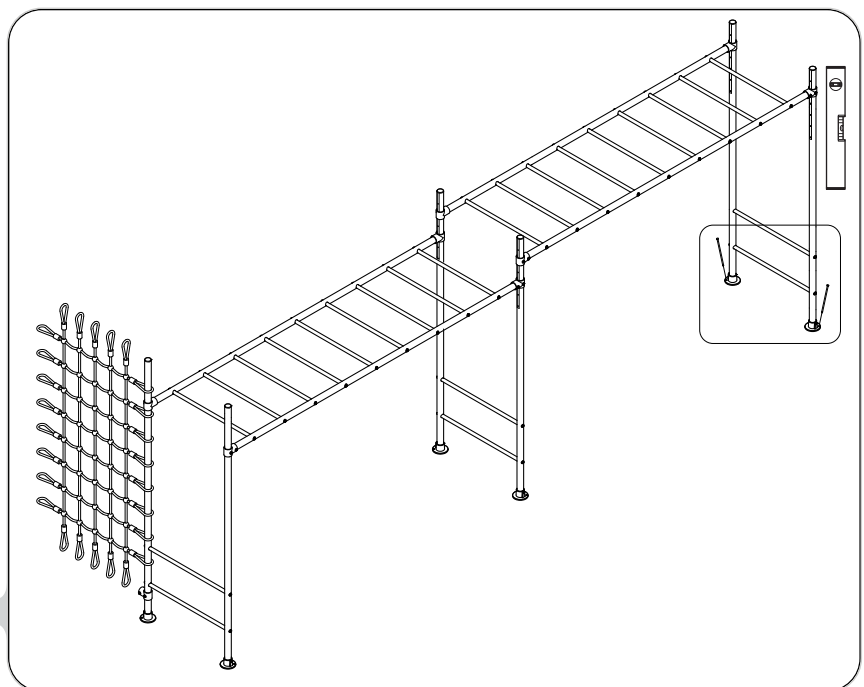
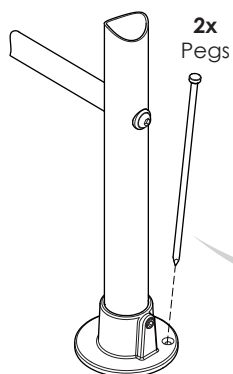

ASSEMBLY INSTRUCTIONS - SWING BAR ASSEMBLY

29 DOUBLE SWING BAR ASSEMBLY X3.

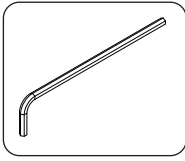

Slide on all fittings. Leave short tees and swing hooks hand tight only for assembly adjustment later, see below for spacing.

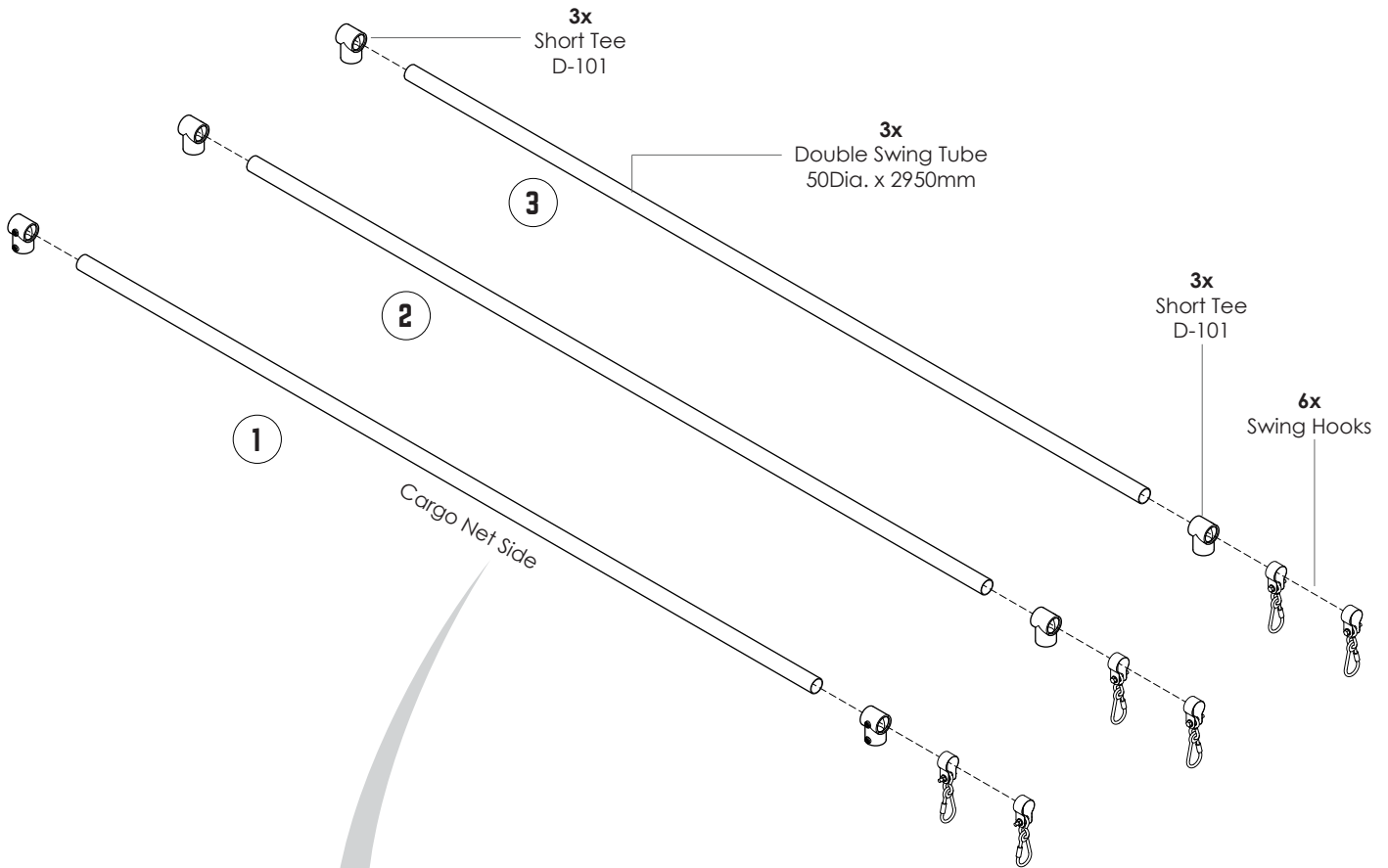

3X DOUBLE SWING BARS ASSEMBLED

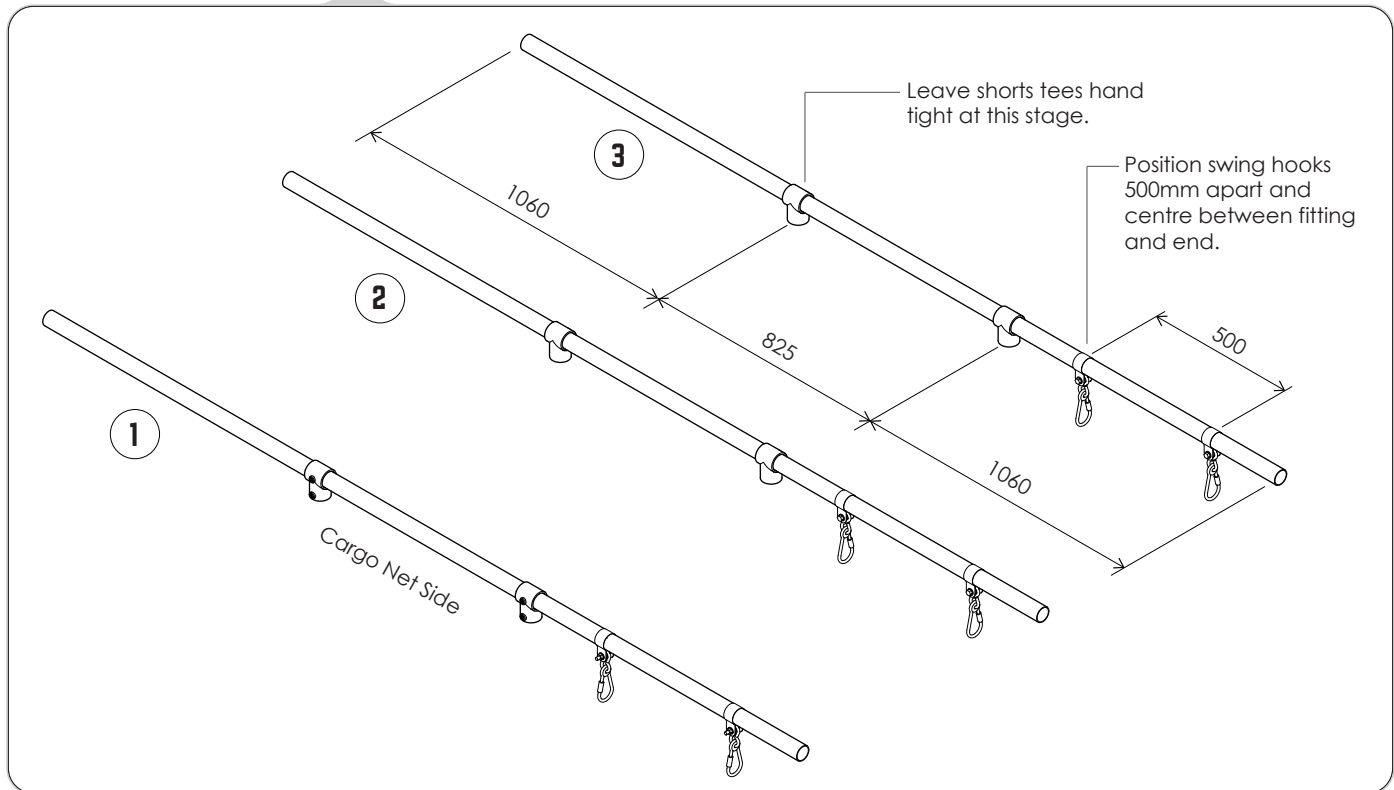

30 ATTACH CARGO NET SWING BAR ASSEMBLY

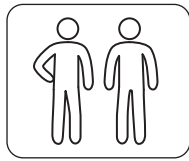
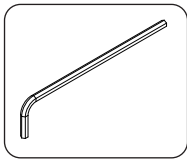

Attach the short tees (on the double swing bar 1) to the main monkey bar ladder legs. The cargo net side swing bar will need to be threaded through the top cargo net hoops before attaching. Fully tighten all grub screws.

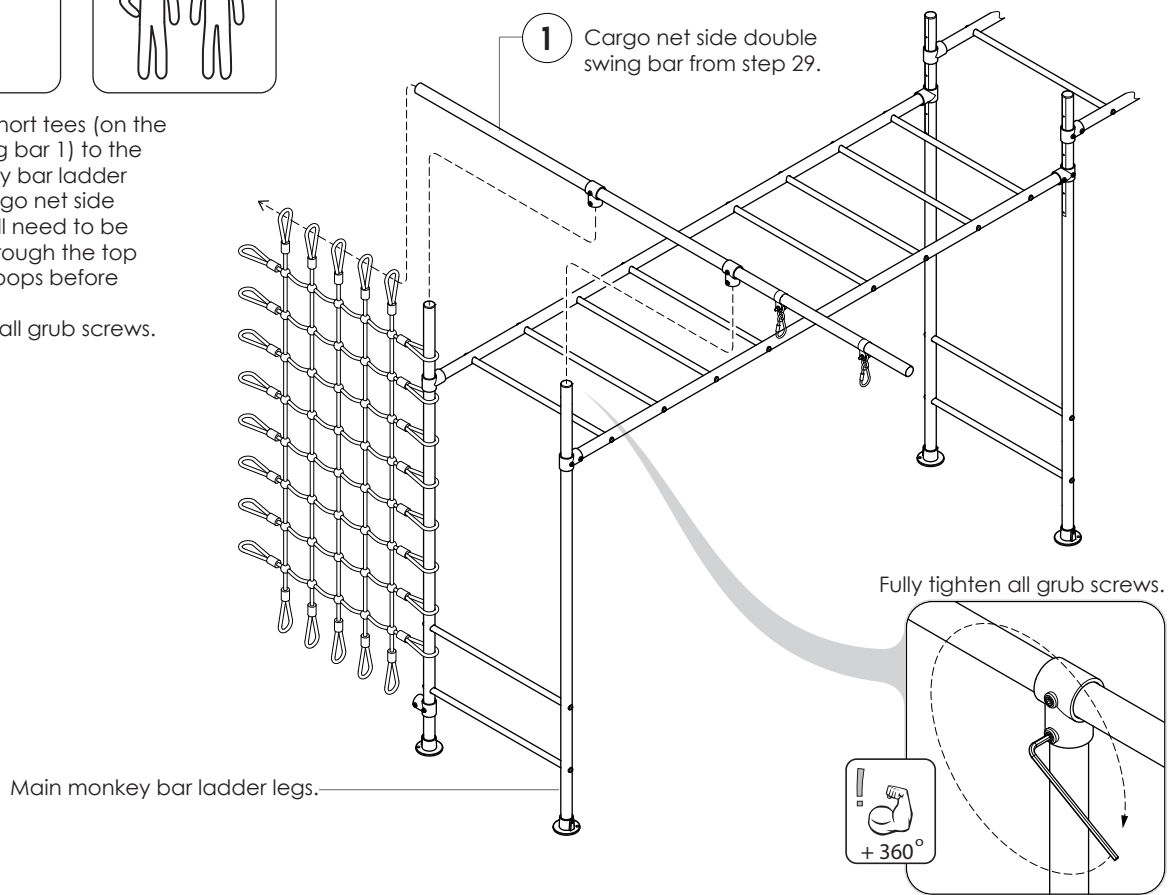

31 ATTACH CARGO NET SWING LEG

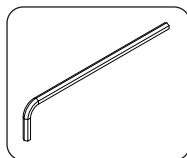

1. Feed the leg tube through the cargo net hoops and short tees.
2. Ensure the leg tube to adj. leg tubes are 1040mm apart top and bottom.
3. Tighten grub screw on base plate & leave all others hand tight for step 32.

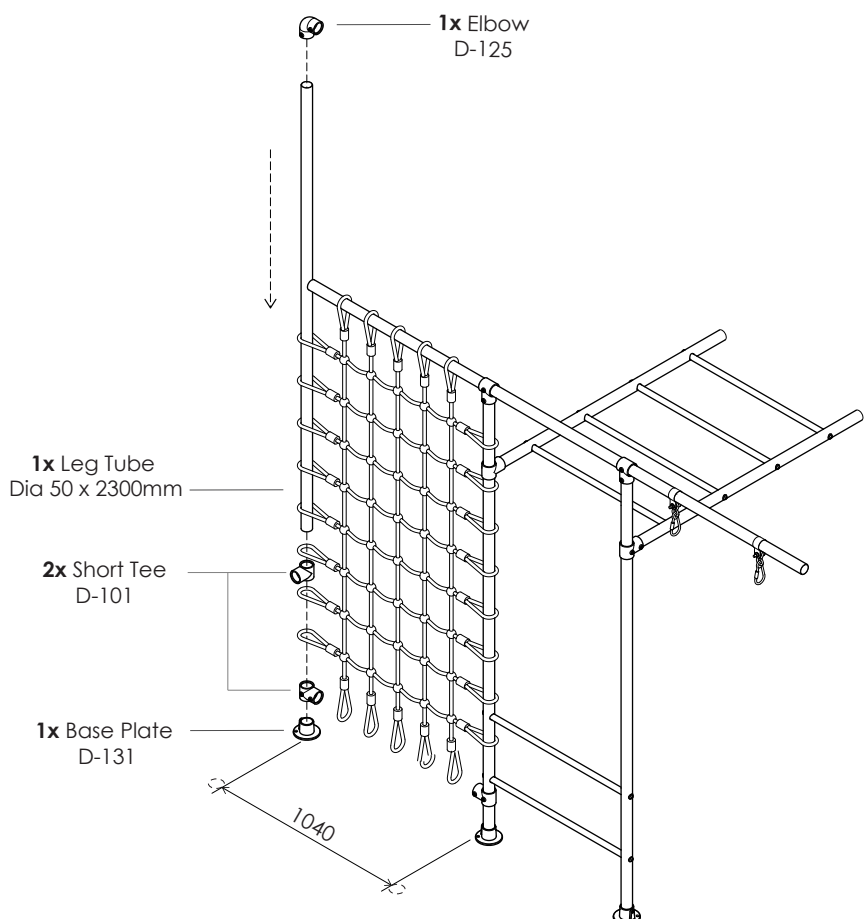

32 ATTACH CARGO TUBE

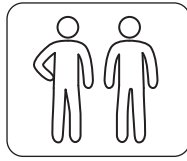
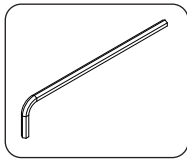

1. Ensure the cargo net gap is 1040mm apart between legs. You may need to loosen top grub screws D & E to slide the swing bar along. Retighten before continuing.
2. Check grub screws on A, B & C are loose.
3. Thread in bottom cargo tube between lower cargo net hoops, pull swing leg outwards & fully engage into A & B short tees.
4. Get second person to stand on tube to make cargo net taught.
5. Fully engage all tubes & tighten all grub screws at cargo net end.

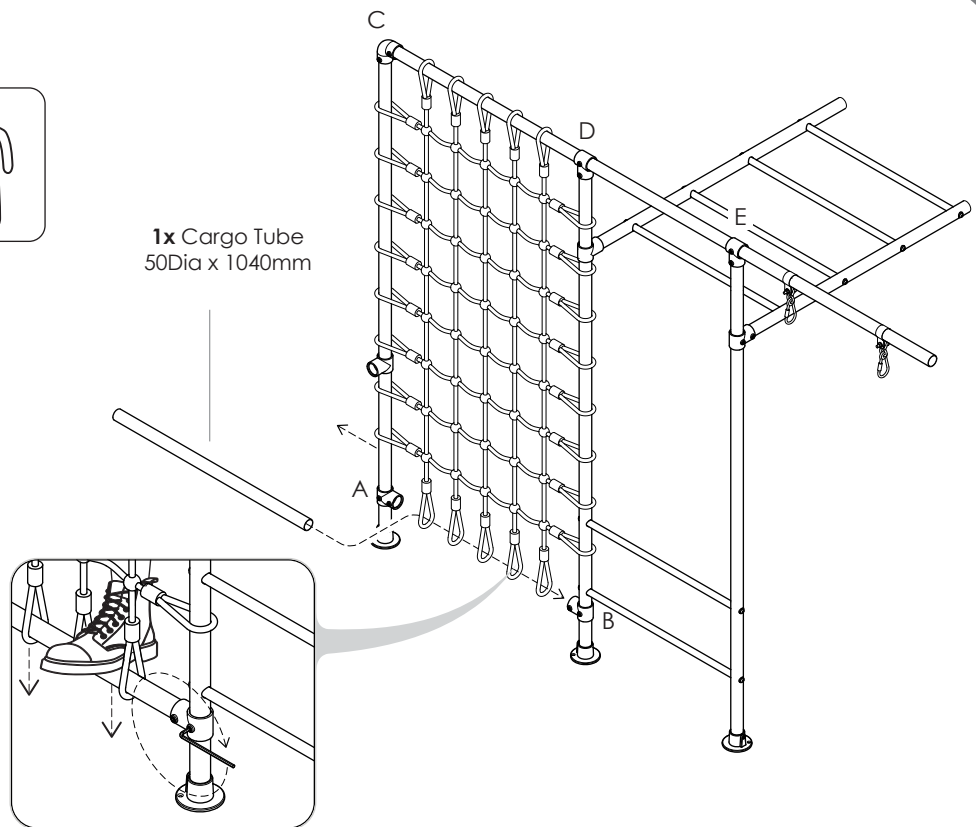

33 ATTACH 2X SWING BAR ASSEMBLIES

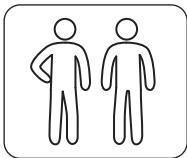
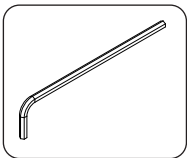

Attach the short tees (on the remaining double swing bars) to the main monkey bar ladder legs. Check the swing bars are level then fully tighten all grub screws.

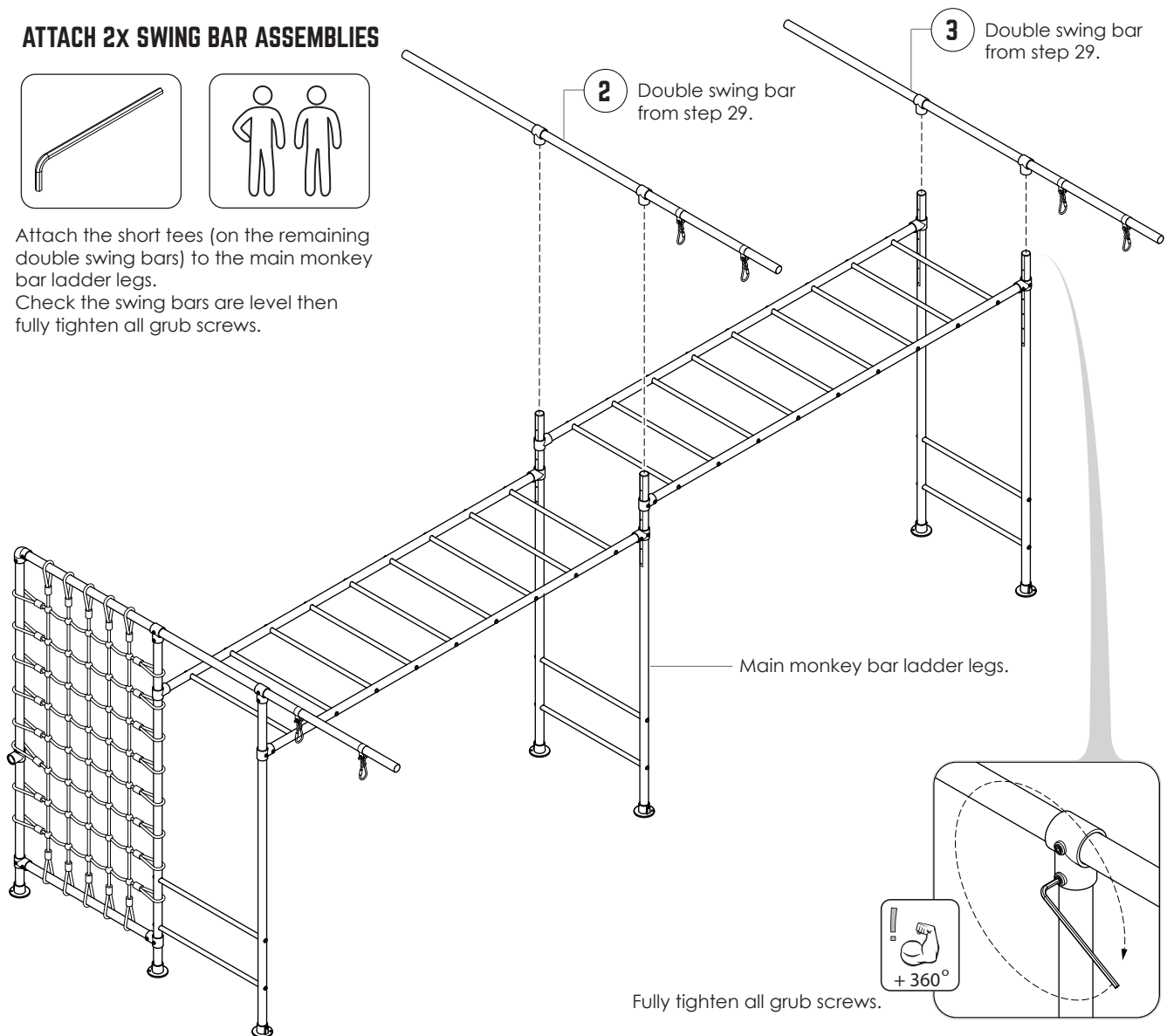

34 ASSEMBLE SWING BAR LEGS x5

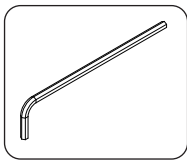

1. On flat level ground slide on all fittings.

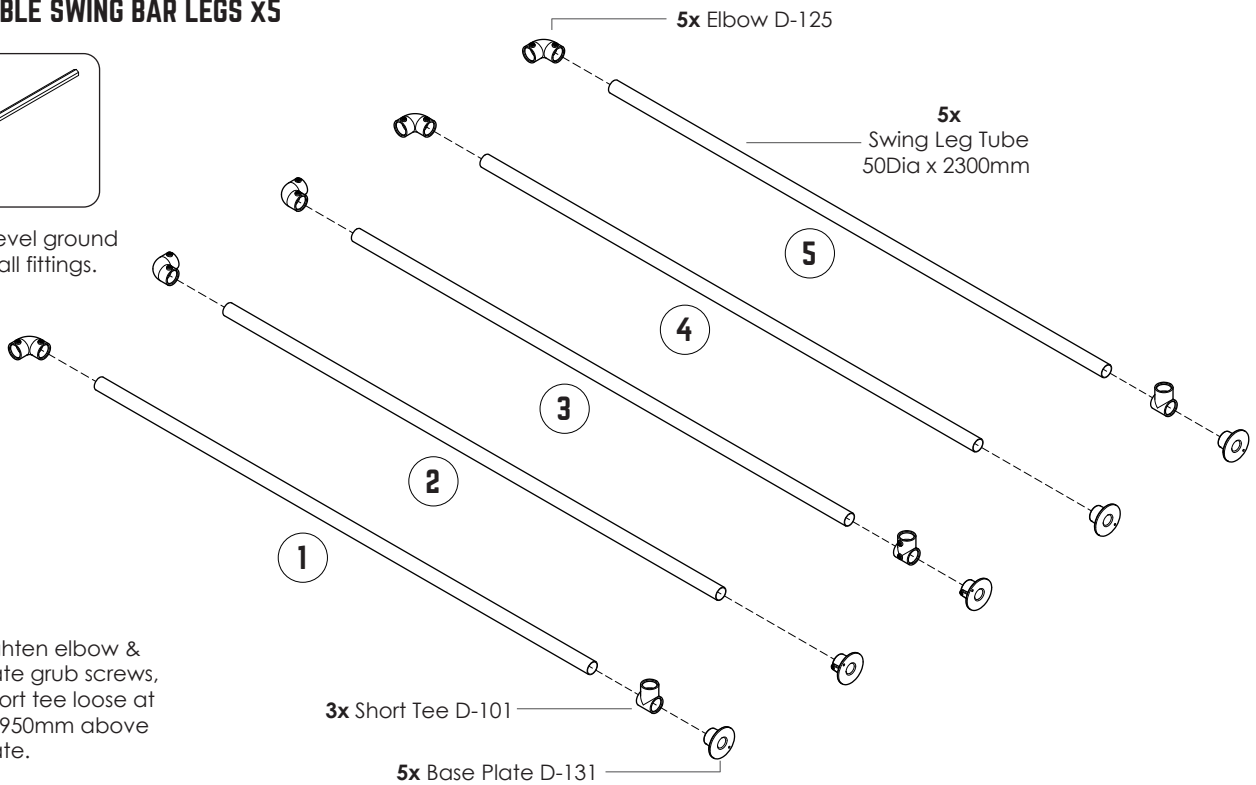

2. Firmly tighten elbow & base plate grub screws, leave short tee loose at approx. 950mm above base plate.

35 ATTACH LEGS x3

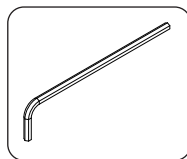

Slide legs onto double swing bars. Fully tighten elbow grub screws.

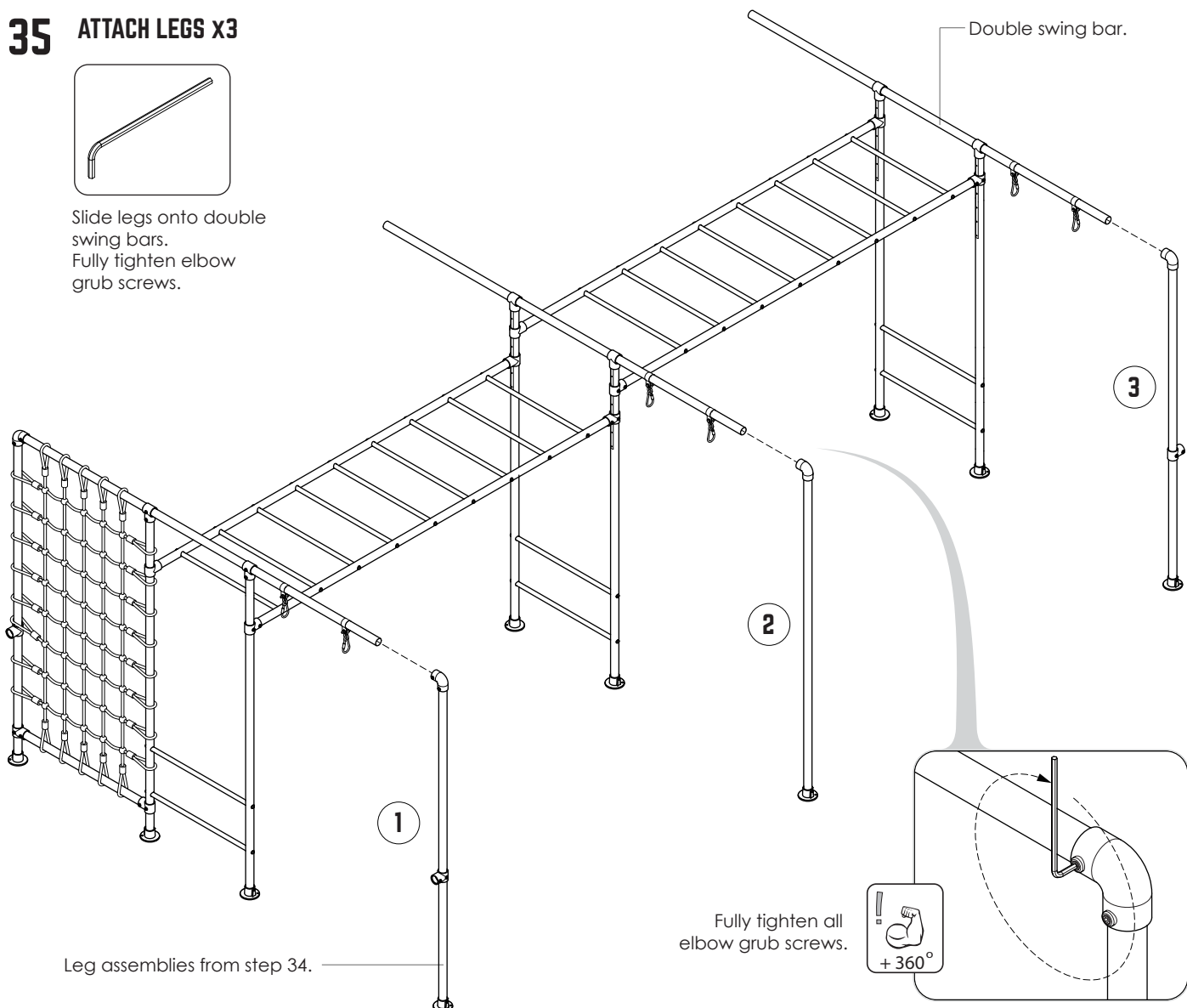

36 ASSEMBLE FLYING FOX

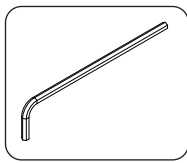

Slide components onto accessories tube.
Slide extra long tees onto ends as per detail
and fully tighten all grub screws.

NOTE: Maximum load on flying fox is 1 user.

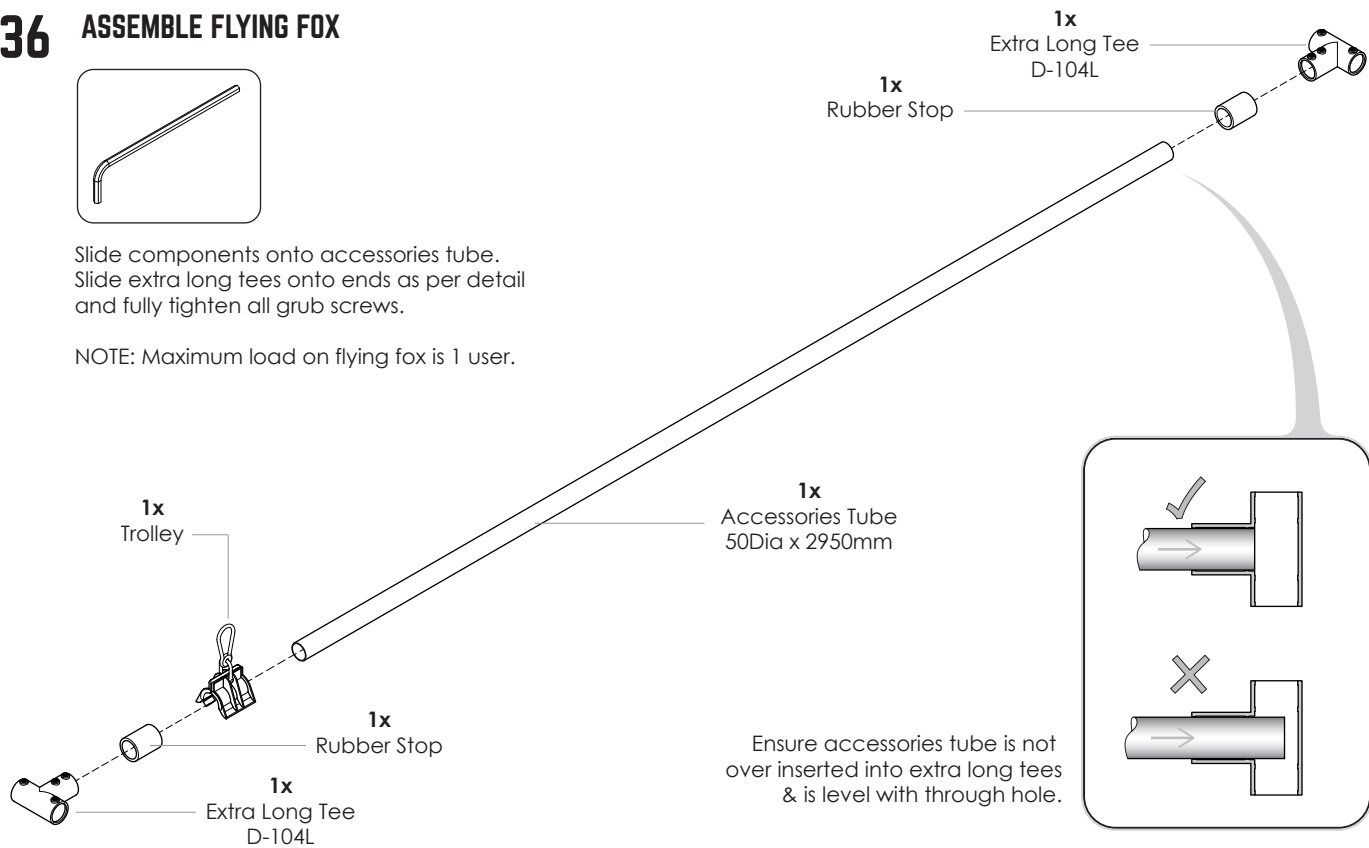

37 ATTACH FLYING FOX

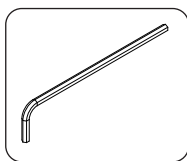

1. Flip assembled flying fox over 180° so that extra long tee grub screws are facing downwards.
2. With 2 people carefully slide the flying fox midway onto the double swing bars.
3. Check it is square and level then tighten all grub screws.

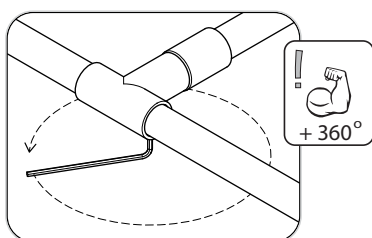

NOTE : Secure flying fox trolley to avoid injuring hands during installation

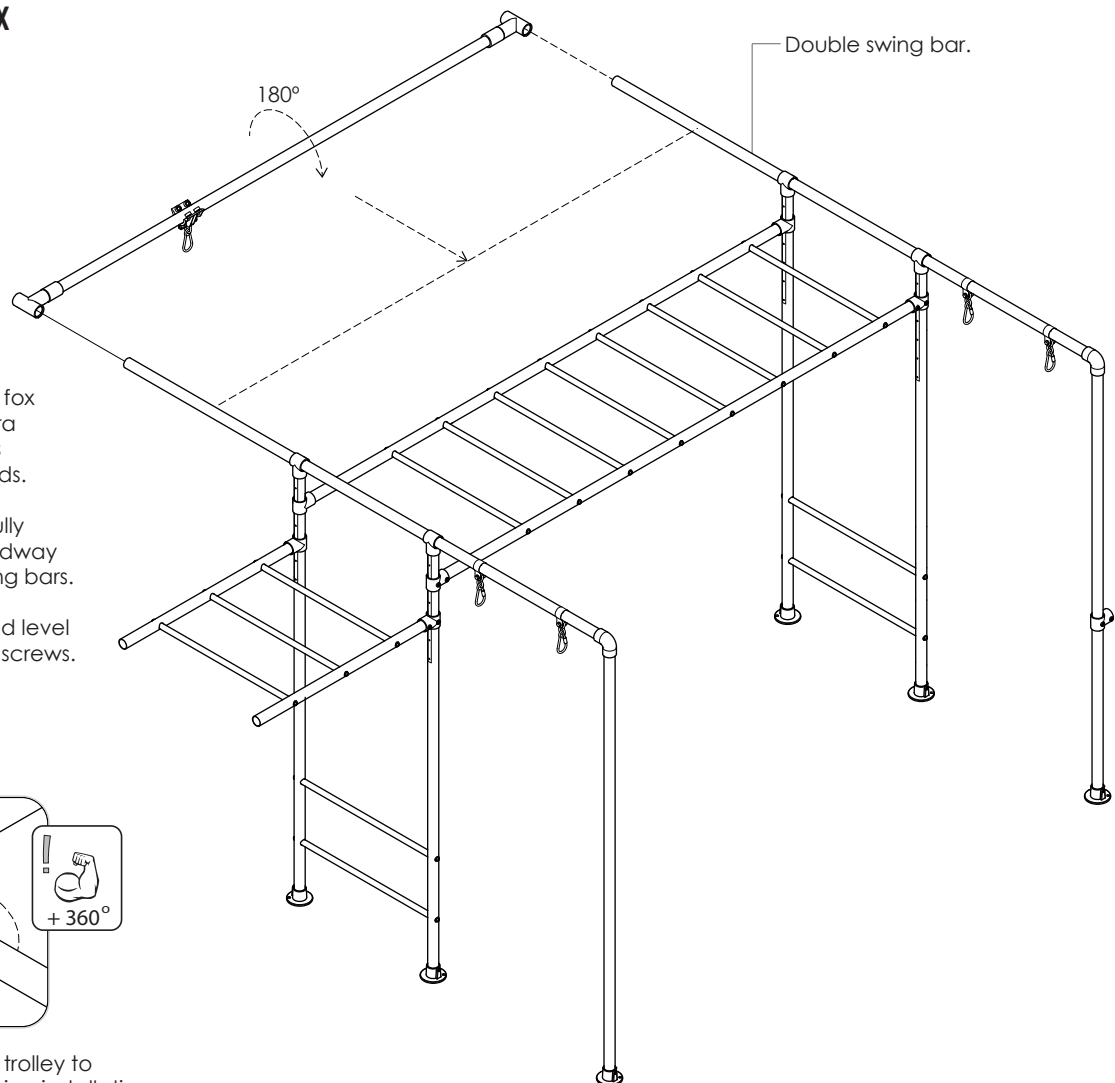

38 ATTACH LEGS X2

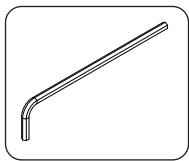

Slide remaining legs onto double swing bars. Fully tighten elbow grub screws.

Leg assemblies 4&5 from step 34.

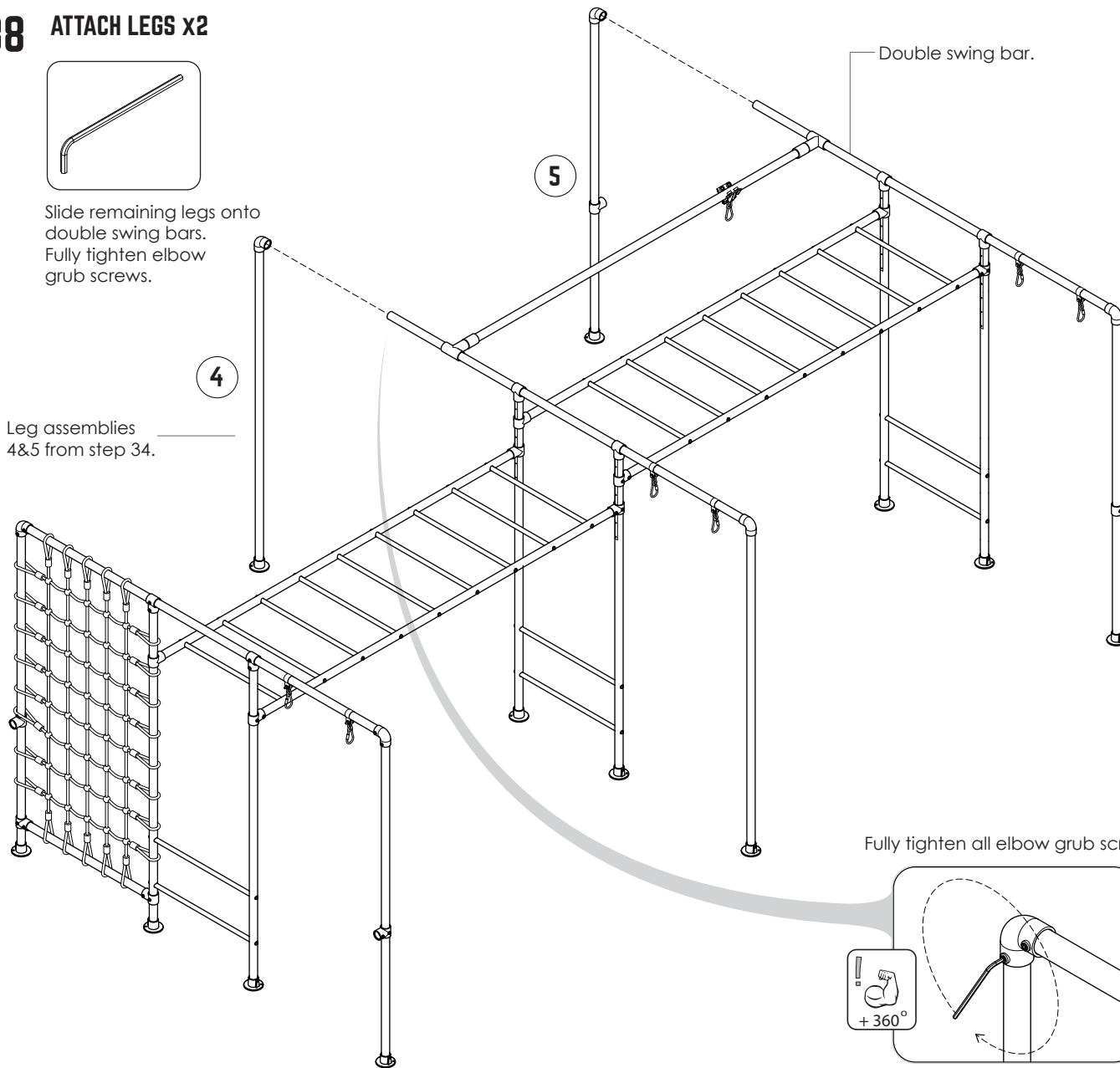

Fully tighten all elbow grub screws.

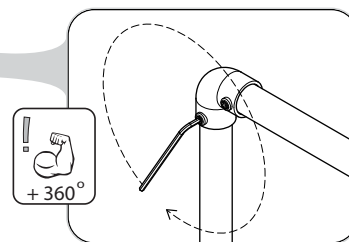

39 SECURE TO GROUND

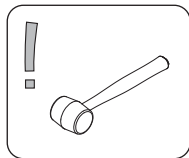
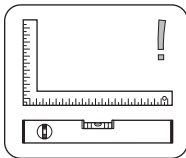

1. Check level and square.
2. Hammer in all remaining pegs x6.

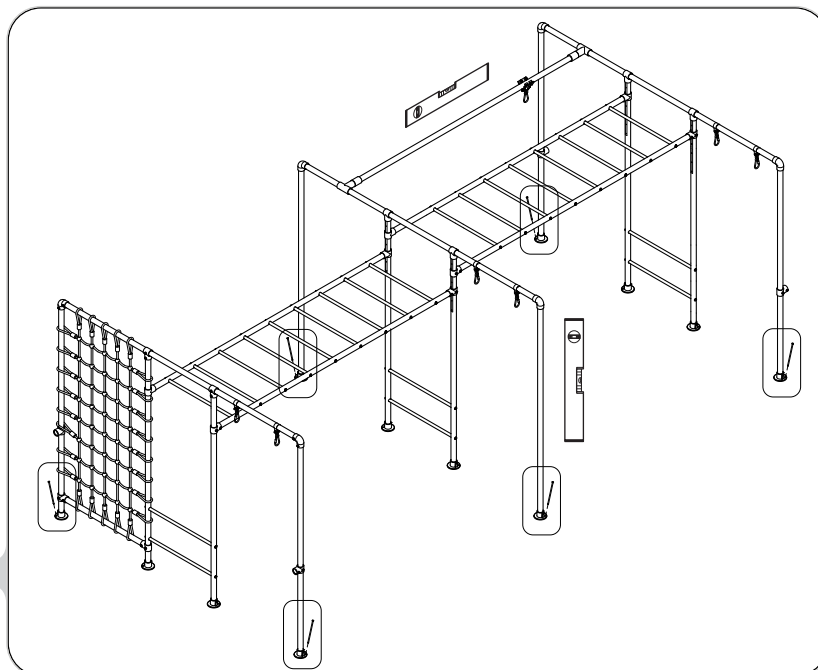

40 ATTACH TWIRLY WHIRLY BARS x4

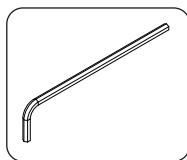

1. Adjust & rotate short tees A,B,C & D to align level with twirly whirly bars.
2. Tighten all grub screws fixing twirly whirlys to legs.

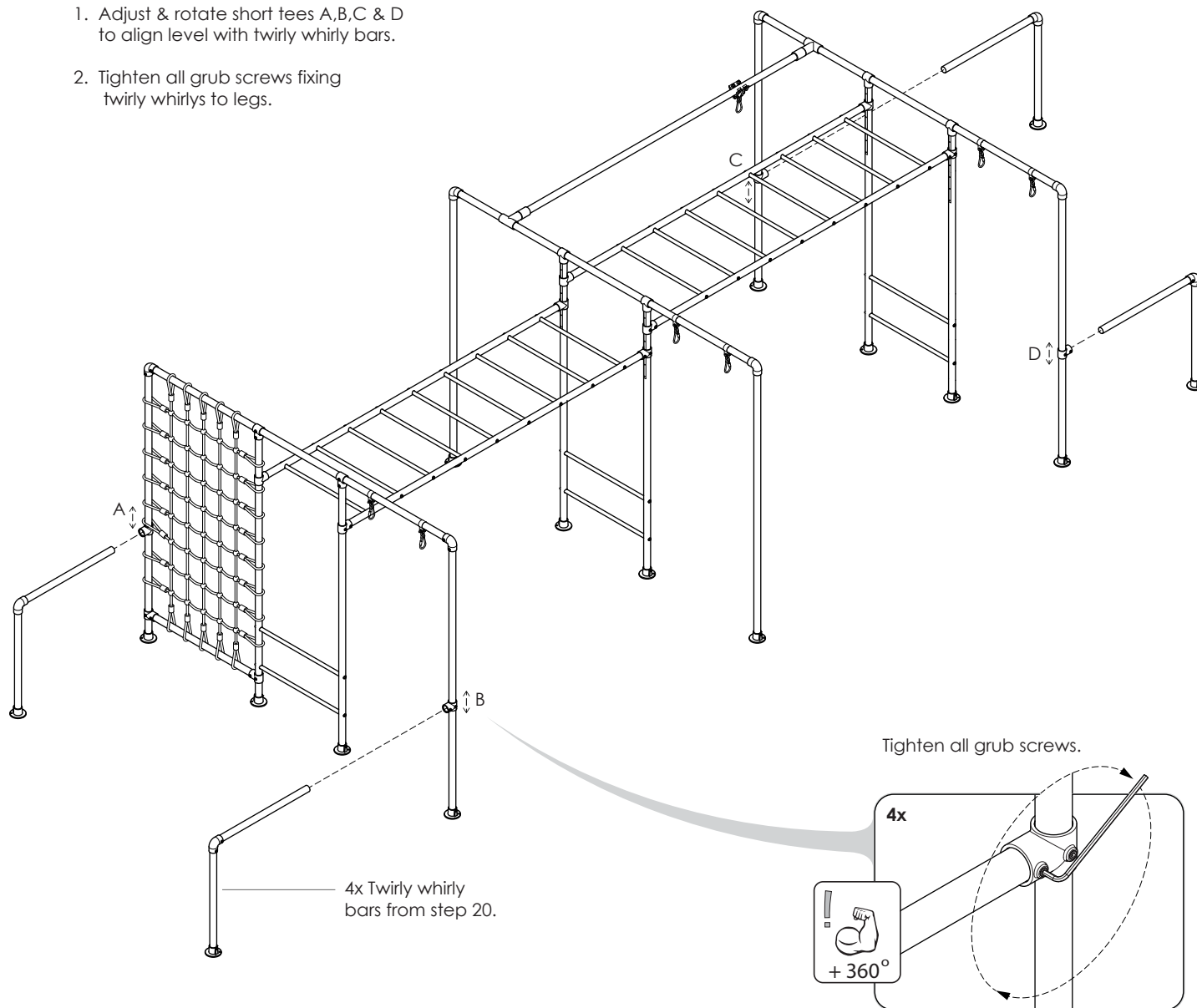

41 CHECK ALL FITTING GRUB SCREWS ARE FULLY TIGHTENED

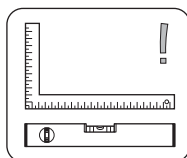
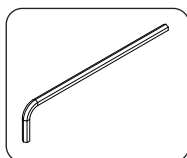

1. Ensure frame is square and level.
2. Firmly tighten all grub screws and bolts.

42 LOAD YOUR TWIRLY WHIRLY BARS x4

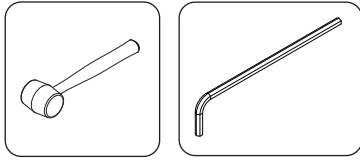

To reduce movement in your frame load your twirly whirly bars as follows.

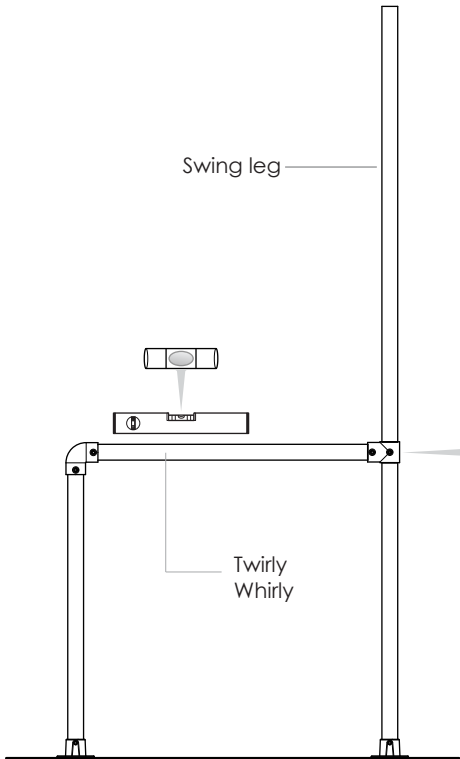

1. Ensure twirly whirly is level and square & swing leg is pegged down.

2. Loosen the grub screw fixing the short tee to the swing leg.

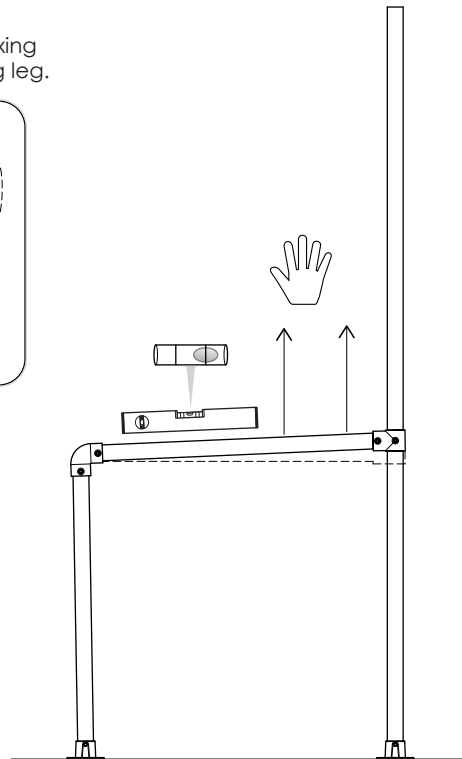
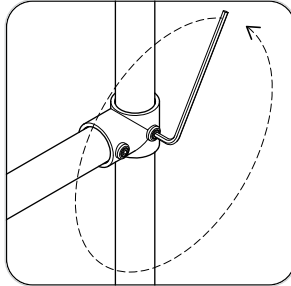

3. Pull upwards on the twirly whirly bar to make a slight angle. (Half a bubble off center on the level)

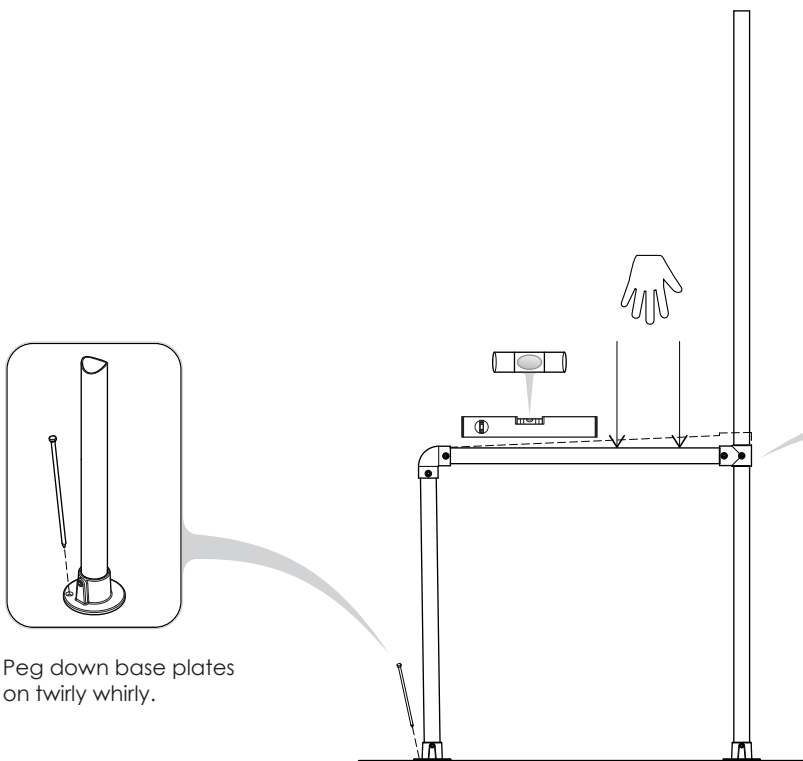

4. Peg down base plates on twirly whirly.

5. Push down on the twirly whirly bar until horizontal bar is level.

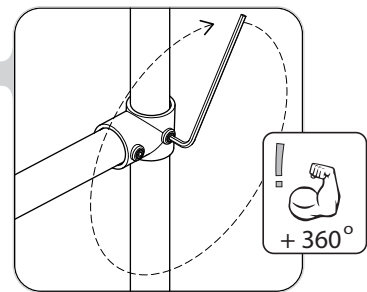

6. Tighten grub screw fixing the short tee to the swing leg tube. Apply to all twirly whirlys.

REFER TO VIDEO SECTION OF WEBSITE [HTTP://WWW.FUNKYMONKEYBARS.COM/PAGES/VIDEOS](http://www.funkymonkeybars.com/pages/videos)

43 ATTACH ACCESSORIES (IF APPLICABLE)

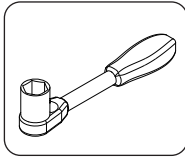

Attach new accessories in desired position (if applicable) and tighten swing hook bolts with ratchet.

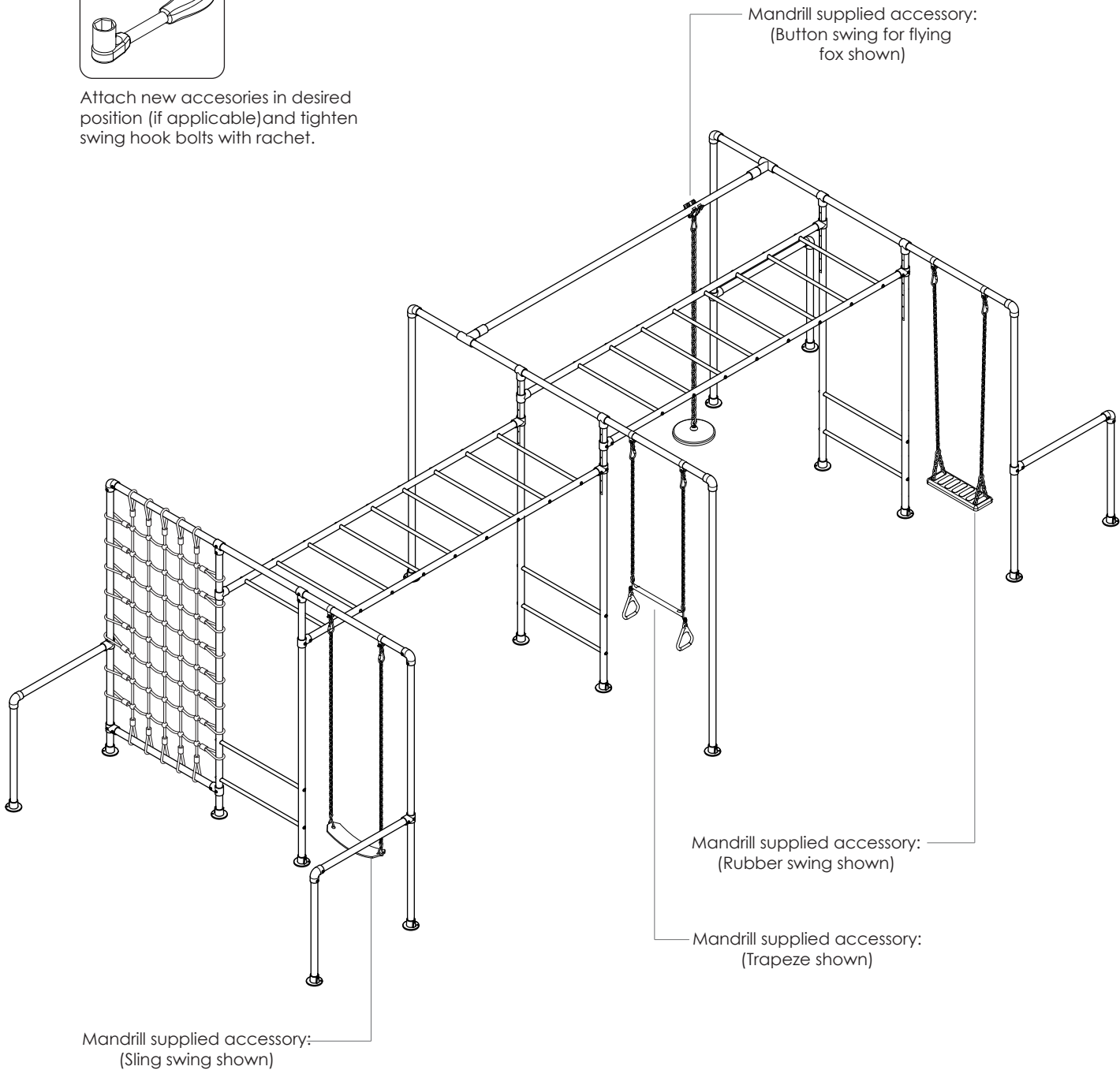

44 FINAL CHECKS

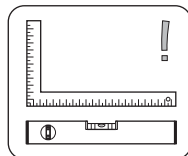
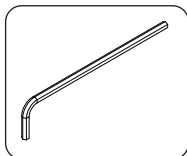

1. Ensure frame is square and level.
2. Firmly tighten all grub screws and bolts.
3. All base plates are pegged down.

Apply your manufacturing sticker to a leg tube.

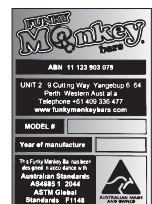

45 MAINTENANCE.

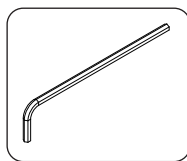
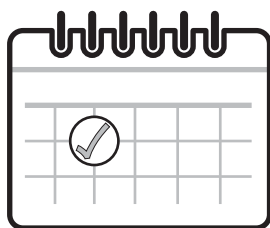

At the beginning of each heavy play session (especially a party) and twice a month during play season ensure;

1. Tighten all hardware - grub screws, nuts and bolts.
2. Pegs are in place and fully secure.
3. Lubricate all metallic moving parts with WD40 or Vaseline - (trolley and swing hooks.)
4. Ensure your frame is level and square.

FAILURE TO DO SO COULD RESULT IN SERIOUS INJURY OR DEATH.

**FOR MORE INFORMATION AND ASSEMBLY TIPS
PLEASE REFER TO OUR WEBSITE VIDEO INSTRUCTION SECTION AT
[HTTP://WWW.FUNKYMONKEYBARS.COM/PAGES/VIDEOS](http://www.funkymonkeybars.com/pages/videos)**

46 HAVE FUN



NOTES.



ABN 72 164 496 520



1300 912 198



info@funkymonkeybars.com



www.funkymonkeybars.com



9 Cutting Way,
Yangebup WA 6164



WE ARE SOCIAL MONKEYS



Australian Government
IP Australia

All Funky Monkey Bars® designs are registered and protected under IP Australian certification.