

FUNKY Monkey bars[®]

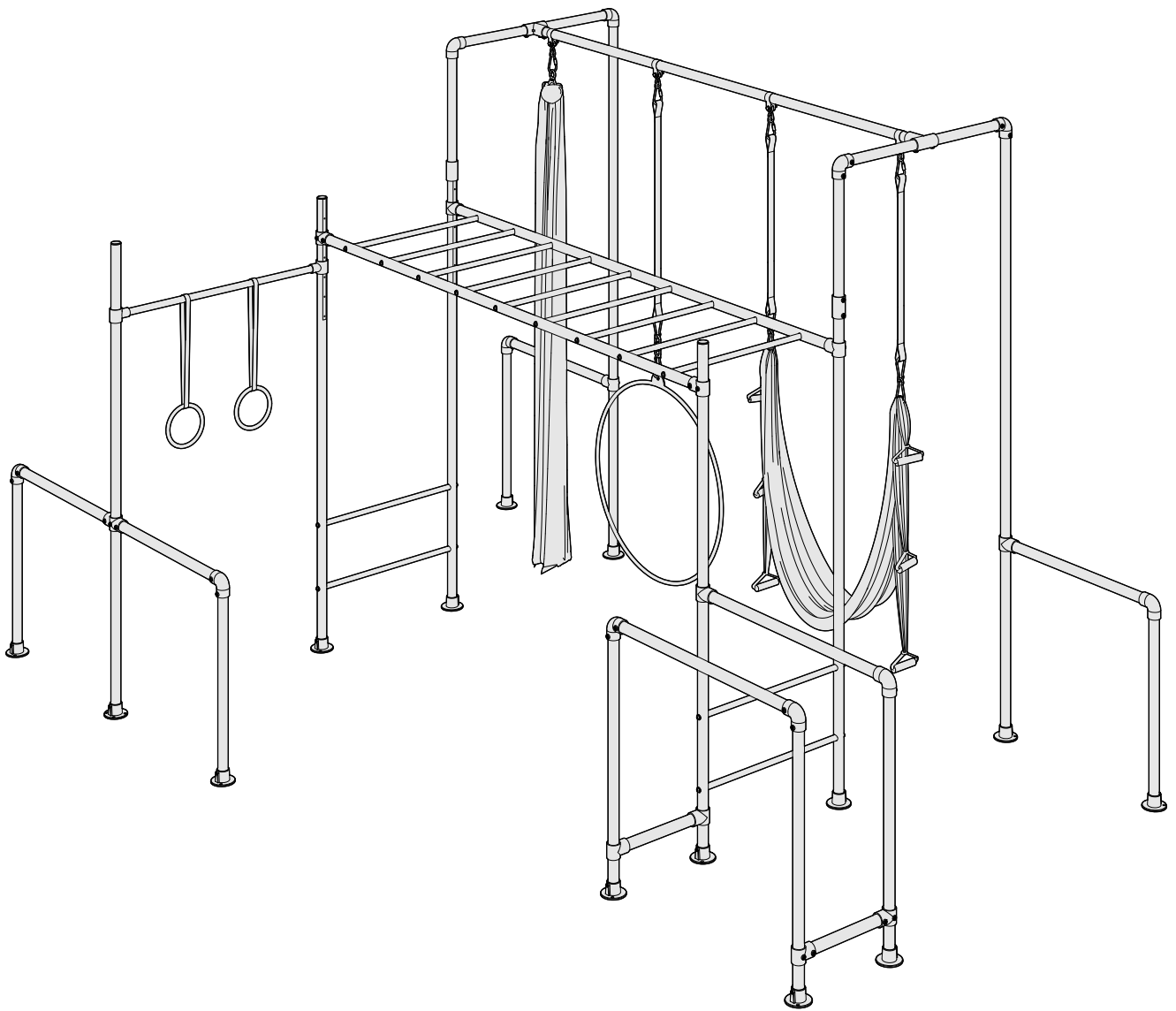

THE AERIAL TAMARIN ASSEMBLY INSTRUCTIONS

CONTENTS

Warnings	Page 1
Load Rating	Page 3
Dimensions	Page 4
Assembly Tips	Page 5
Inventory	Page 7
Assembly Instructions	Page 9
Ladder Bar Assembly	Page 9
Leg Assembly	Page 11
Twirly Whirly Bar Assembly	Page 16
Main Monkey Bar Assembly	Page 17
Dip Bar Assembly	Page 19
Gym Bar Assembly	Page 21
Height Extender Assembly.	Page 23
Load Twirly Whirly Bars	Page 28
Maintenance	Page 30

WARNING

PLEASE CAREFULLY READ ALL INFORMATION CONTAINED IN THIS ASSEMBLY MANUAL BEFORE YOU INSTALL AND USE YOUR FUNKY MONKEY BARS®.

SAFETY NOTICE

1. Any person handling or using the Funky Monkey Bars® products must follow the instructions as described in this document. The person in charge of assembling and using the equipment must ensure that the recommendations for use given in this document are seen by all users.
2. Only use the Funky Monkey Bars® after they have been fully assembled and after checking that the fittings are tightened properly (*refer to page 5 - Correct Tightening Method*).
3. DO NOT install your Funky Monkey Bars® over concrete, asphalt, packed earth, wood decking or any other hard surface. A fall onto a hard surface can result in serious injury or death.
4. Inspect all grub screws, bolts and nuts at the beginning of each play session to ensure your Funky Monkey Bars® are tight and secure.
5. Ensure all tubes are fully inserted into fittings until you hear the magic "CLUNK" sound.
6. Ensure your Funky Monkey Bars® are properly secure at ALL times. Pegs are in place and inserted fully into the ground.
7. DO NOT exceed the maximum load/weight limit as recommended by Funky Monkey Bars®.
8. Children should be supervised by an adult at all times.
9. Installing a gym/crash mat under the fall zone area of your Funky Monkey Bars® would be recommended for children learning this new skill. This will reduce the chance of injury and build the child's confidence while they build strength and master the skill.
10. Ensure you have thoroughly read your assembly and installation instructions and viewed our on-line installation videos at <https://www.funkymonkeybars.com/blogs/installation-maintenance-videos>
11. DO NOT climb, sit or stand on top of the monkey bar (horizontal ladder) section.
12. DO NOT jump from the top of any section of the monkey bar.
13. DO NOT use your Funky Monkey Bars® when wet as the steel will be slippery.
14. DO NOT attach items to your frame that are not designed specifically to be used with Funky Monkey Bars®, especially lower quality products that have not been approved by Funky Monkey Bars®.
15. Ensure the height of your Funky Monkey Bars® (horizontal ladder) are set at a level that is age appropriate.
16. DO NOT install your Funky Monkey Bars® over or near objects that could interfere with users in an unsafe way. Maintain a clear area around your Funky Monkey Bars®.
17. DO NOT use your Funky Monkey Bars® while under the influence of drugs and alcohol.
18. Wear clothing free of drawstrings, hooks, loops or anything that could get caught while using your Funky Monkey Bars® and result in entanglement and/or strangulation.

ASSEMBLY

1. Keep small children away from the Funky Monkey Bars® during assembly.
2. Do not attempt to use the Funky Monkey Bars® until it is completely assembled and every fitting is tight and secured.
3. Installation typically takes 3-4 hours to complete. Two people are recommended for assembly.
4. Ensure all fittings are tightened to the correct tightening method as described on page 5.
5. Assembly should be carried out on clean, dry, level surface

Please refer to the video section on the Funky Monkey Bars® website for more handy tips and assembly instructions at <http://www.funkymonkeybars.com/pages/videos>

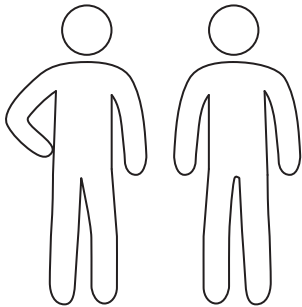

Assembly requires 2 adults.

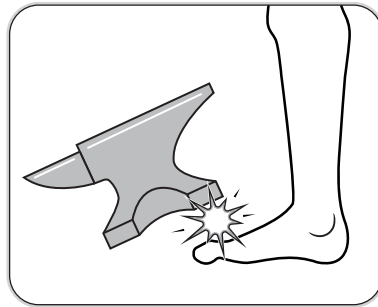

Heavy items !

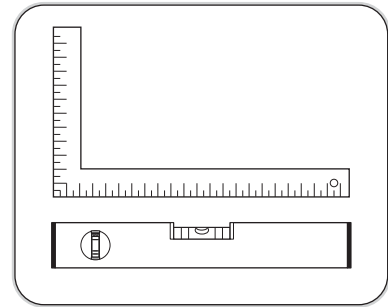

Work on flat level surface.

LOCATION

1. A safe fall zone around your Funky Monkey Bars® is essential. A minimum distance of 1.5m to 2m (5 ft to 6.5ft) is recommended around the elevated hanging points of your Funky Monkey Bars®.
2. Place your Funky Monkey Bars® on level ground, away from any structure or obstruction such as a fence, garage, house, overhanging branches, laundry lines or electrical wires and remove any obstructions beneath your Funky Monkey Bars®.
3. Ensure your Funky Monkey Bars® are positioned away from retaining walls, pool fences, structures and other play equipment. Maintain a clear space around the whole perimeter of your Funky Monkey Bars®.
4. Place your Funky Monkey Bars® on the most level surface available.

MAINTENANCE

1. At the beginning of each heavy play session we recommend the following maintenance processes be performed on your Funky Monkey Bars®:
 - Tighten all bolts, grub screws and applicable hardware (as per page 5)
 - Lubricate all metallic moving parts as per instructions (flying fox, swing hooks etc)
 - Check all protective coverings on bolts, pipes, edges and corners. Replace if they are loose, cracked or missing.
 - Check all moving parts including swing seats, shackles, snap hooks, chains and trolleys for wear, rust, or other deterioration. Replace as needed.
2. Twice a month during play season we would recommend the following maintenance processes be performed on your Funky Monkey Bars®:
 - Tighten all connections and hardware
 - Check all protective coverings on bolts, pipes, edges and corners. Replace if they are loose, cracked or missing.
3. Once a month during play season we would recommend the following maintenance processes be performed on your Funky Monkey Bars®:
 - Lubricate all metallic moving parts as per instructions (flying fox, swing hooks etc). If swings start to squeek then lubricate swing hooks.
 - Check all moving parts including swing seats, ropes, chains and trolleys for wear, rust, or other deterioration. Replace as needed.
 - Owners shall be responsible for maintaining the legibility of any warning labels.

For additional information concerning your Funky Monkey Bars®, please contact our customer service team or check our website for any important updates. Phone -1300 912 198 or www.funkymonkeybars.com



QUALITY & INDEPENDENT TESTING

At Funky Monkey Bars® we take the quality of our designs and safety very seriously. All Funky Monkey Bars® frames go through a stringent, independent structural testing process prior to being made available for release to our customers.

Our frames are designed within the parameters of the Australian Standard for Playground Equipment AS4685.1:2014.

The structural integrity of our frames has been tested for performance through a combination of engineering calculations and physical testing. The tests have been performed by independent, certified structural engineers in accordance with Australian Standard for Playground Equipment AS4685.1:2014 and European Standards EN1176-1:2008.

The independent testing conducted on The Aerial Tamarin certified the frame to a load rating of 1464kgs or 24 users.

LOAD TESTING CERTIFICATION				
DATE OF TEST	MODEL	NUMBER OF USERS	USER LOAD (KG)	LOAD RATING (KG)
21 June 2019	The Aerial Tamarin	24	61	1464
I hereby confirm all testing was undertaken in accordance with Physical Testing of Structural Integrity requirements of AS 4685.1: 2014 App C / EN 1176-1:2008 ^o except where noted below;				
COMMENTS: Maximum number on accessories bar to be 3 users.				
APPROVED BY: Funky Monkey Bars® 		WITNESSED BY: Independent Engineer 		
DATE : June 2019		DATE : June 2019		

**FUNKY MONKEY BARS®
THE AERIAL TAMARIN OVERALL DIMENSIONS**

A minimum of 2.0 Metres clear fall zone is recommended around the elevated hanging points of your Funky Monkey Bars®.

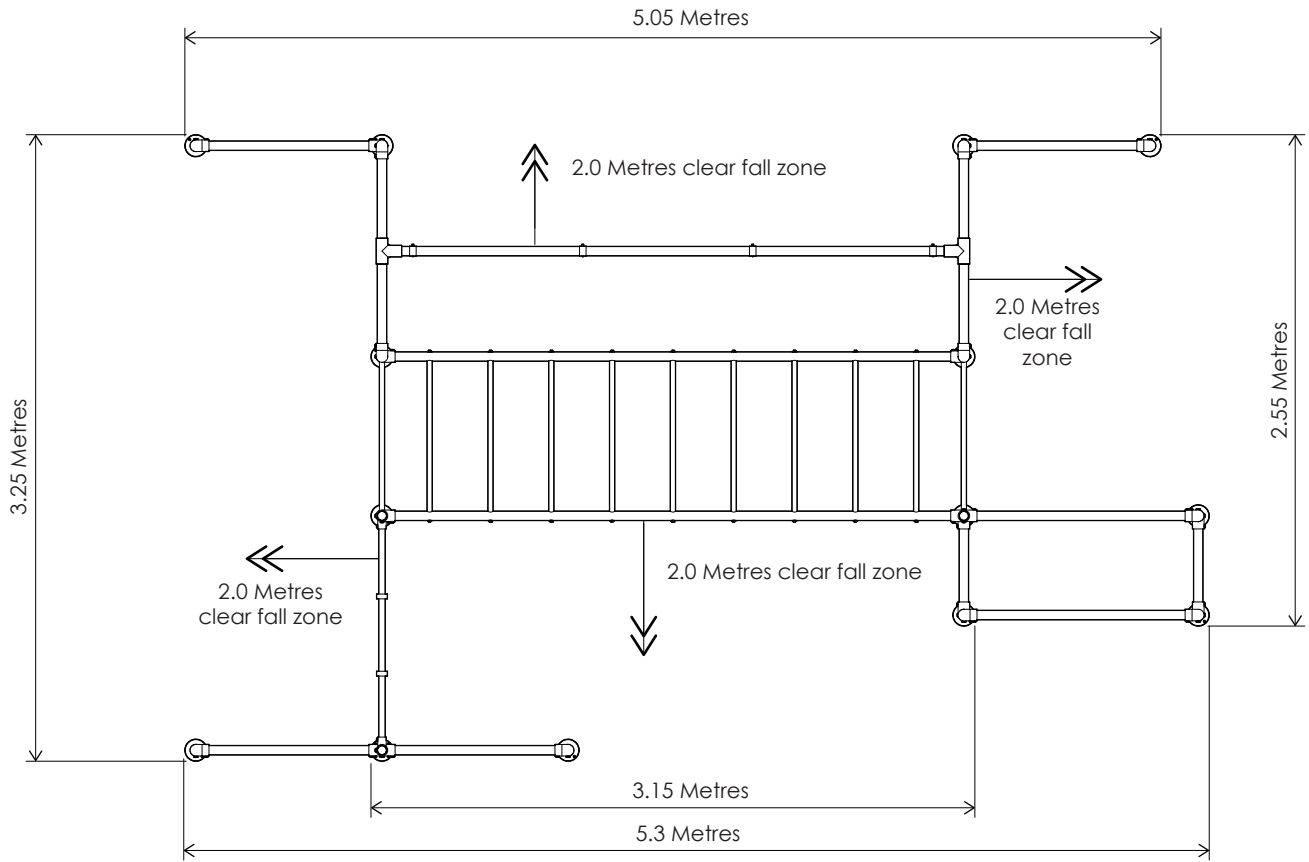

PLAN VIEW
(not to scale)

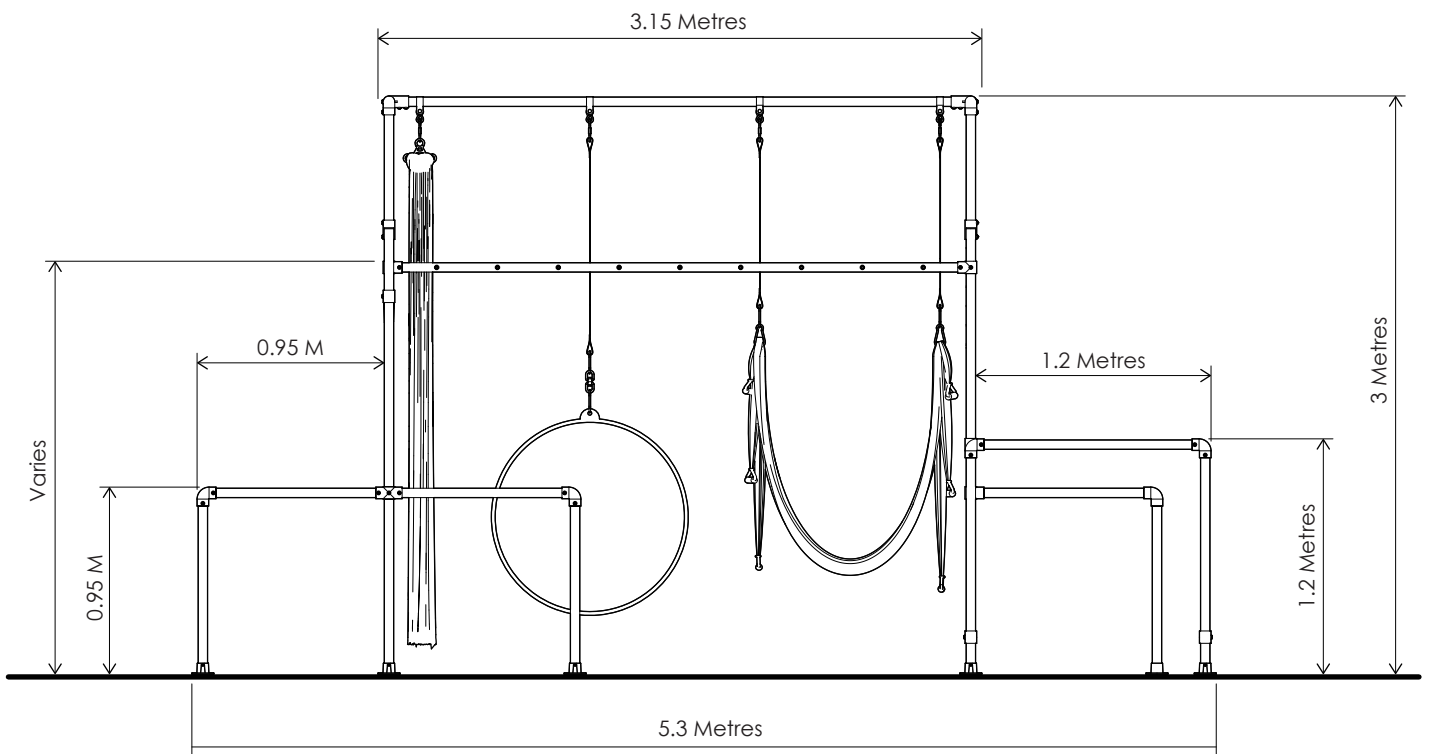

SIDE VIEW
(not to scale)

CORRECT INSERTION INTO FITTINGS - (INDICATIVE DIAGRAM SHOWN)

All tubes must be fully inserted until contact is made with adjoining tube.

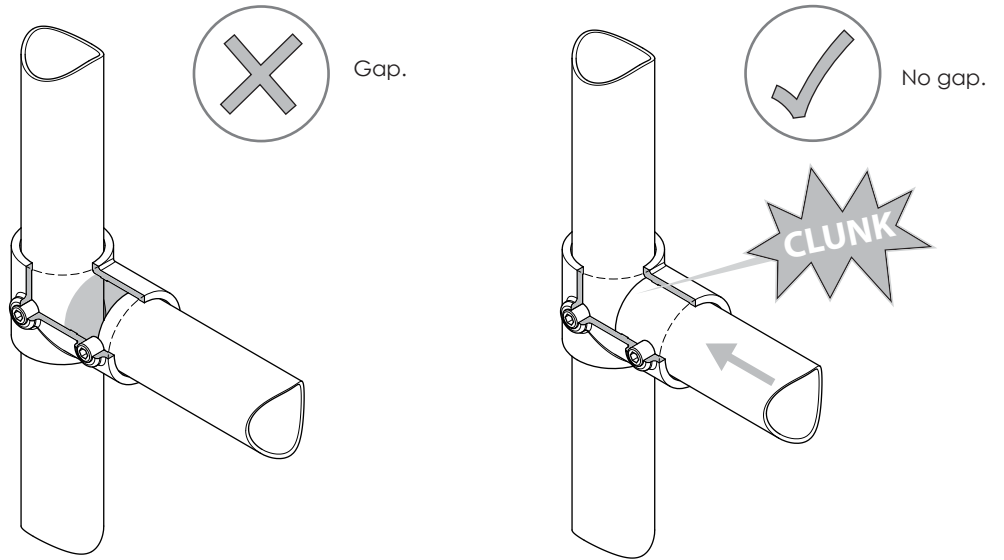

CORRECT TIGHTENING METHOD OF GRUB SCREWS - (INDICATIVE DIAGRAM SHOWN)

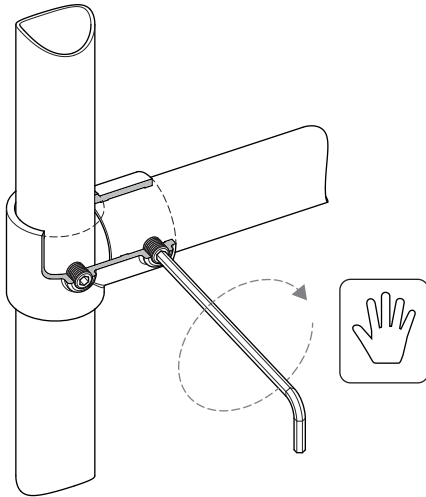

1. With long end of allen key, hand tighten grub screw as much as possible.

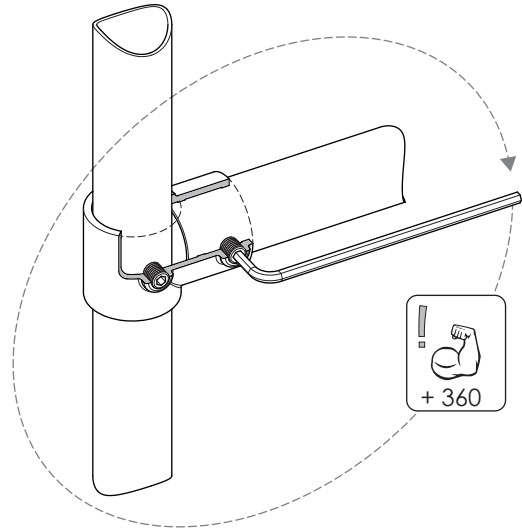

2. Using other end of the allen key do one full 360 degree turn as a minimum, use muscles!



CORRECT TIGHTENING METHOD OF RUNG BOLTS - (INDICATIVE DIAGRAM SHOWN)

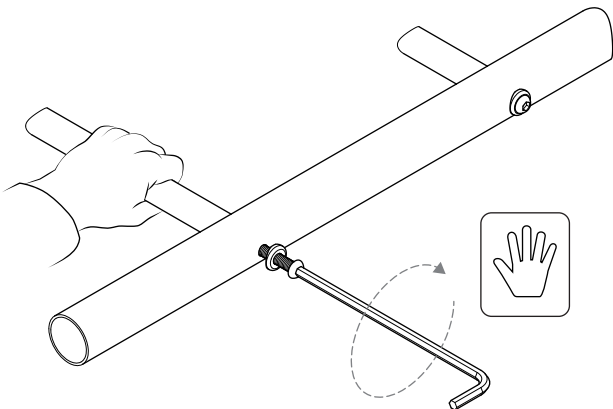

1. With long end of allen key, hand tighten bolt hard up against washer and outside of tube. Hold rung to avoid rotation.

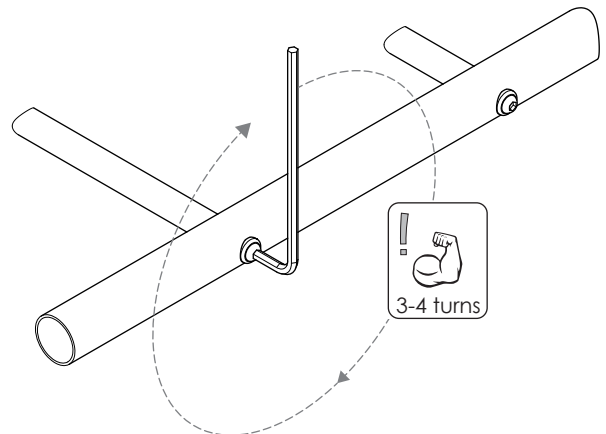

2. Using short end of the allen key fully tighten, approximately 3-4 full turns .



IT IS CRITICAL YOUR MAIN FRAME IS 100% SQUARE AND LEVEL (INDICATIVE DIAGRAM SHOWN)

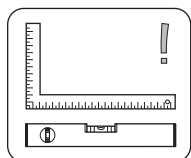

Check assembly is 100% level, square & straight.

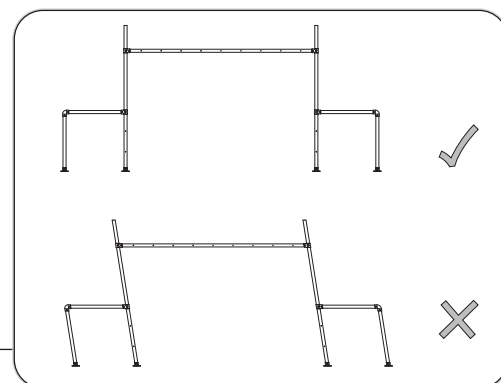
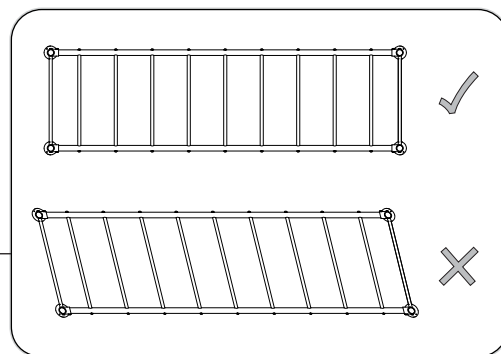
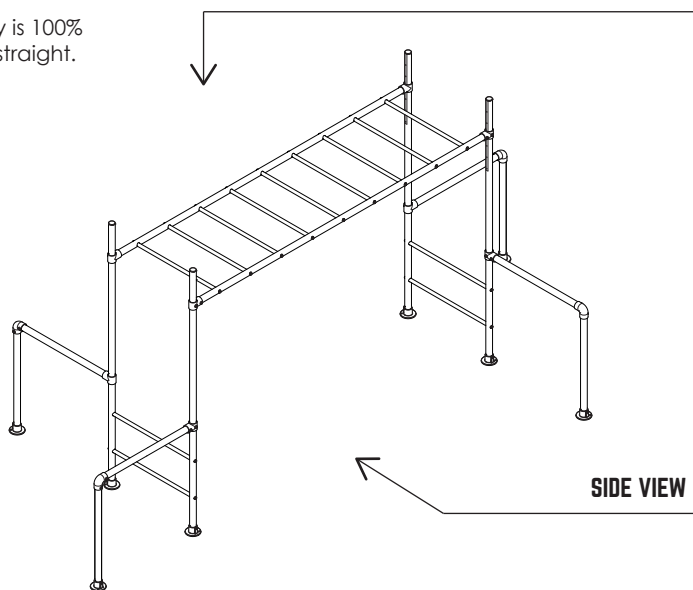

If your frame is not straight or level remove pegs, loosen grub screws, re-adjust re-tighten and re-peg the frame.

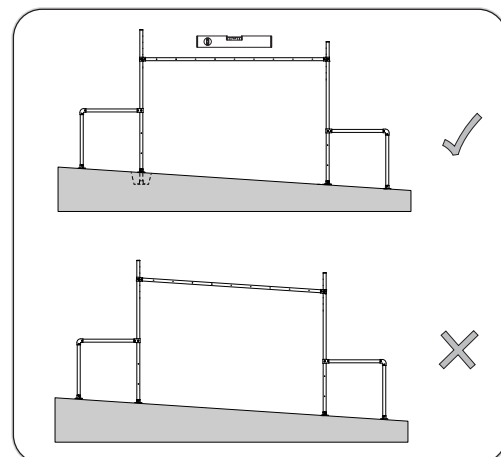

INSTALLATION ON A SLOPE

If your frame is being installed on a slope ensure the monkey ladder bar is level. Either install at different heights on the legs or dig down at one end until level.

TYPICAL FITTING ORIENTATION - (INDICATIVE DIAGRAM SHOWN)

Unless otherwise stated all grub screws and fittings should face downwards and outwards. This will reduce weathering damage, help with assembly and ease of maintenance.

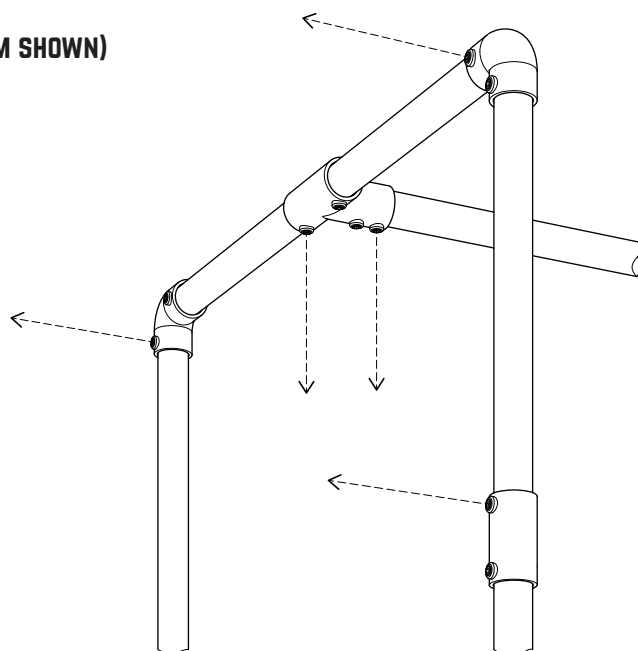

TOOLS REQUIRED FOR INSTALLATION

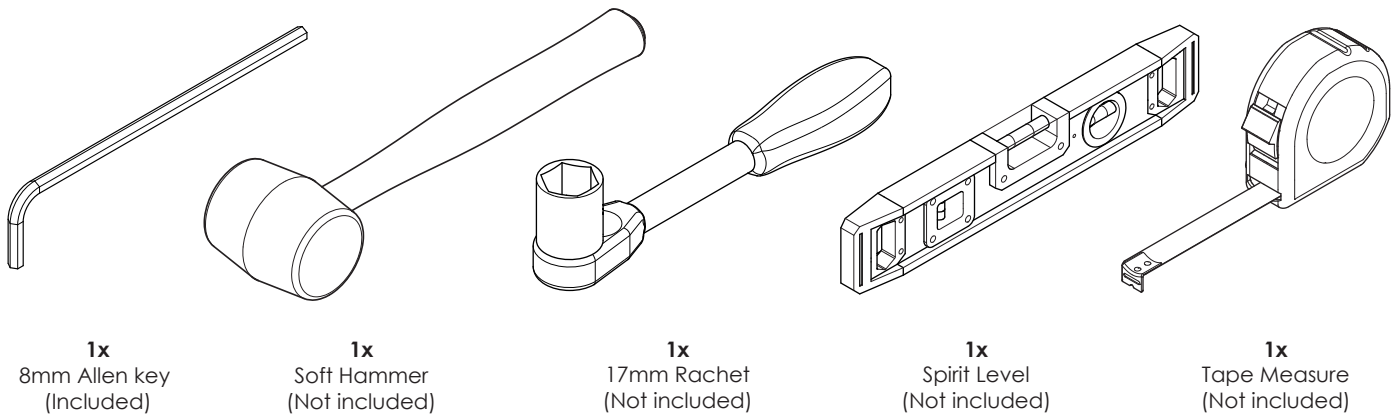

TUBES

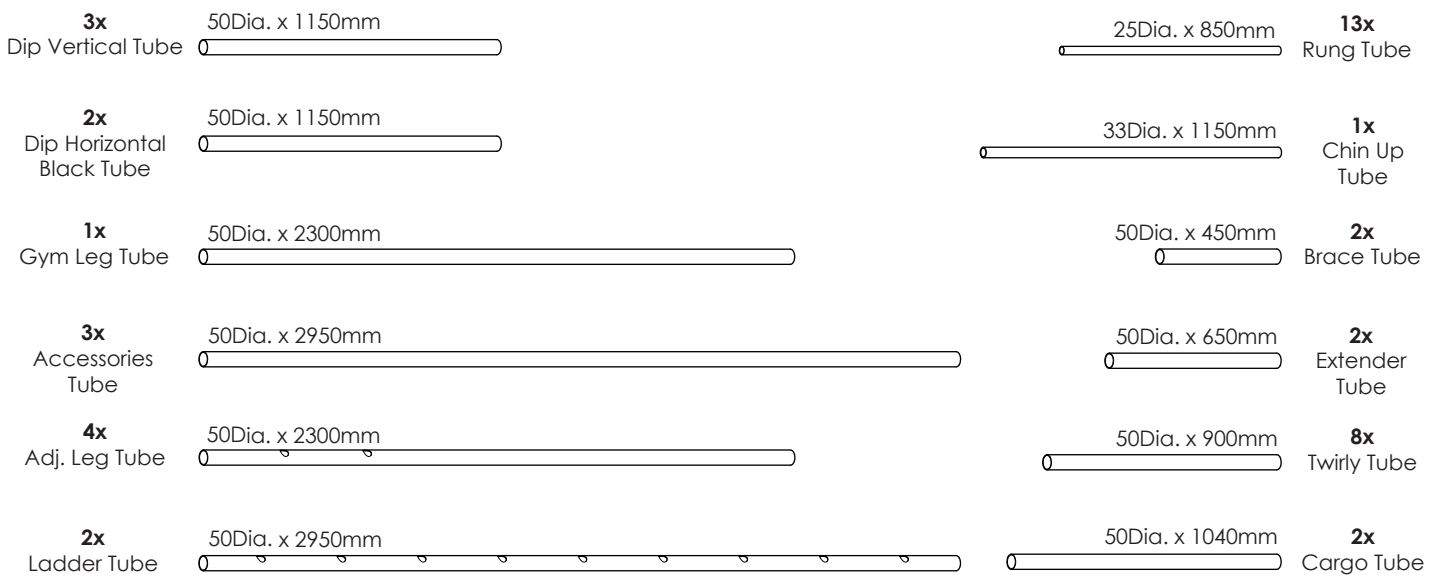

FITTINGS

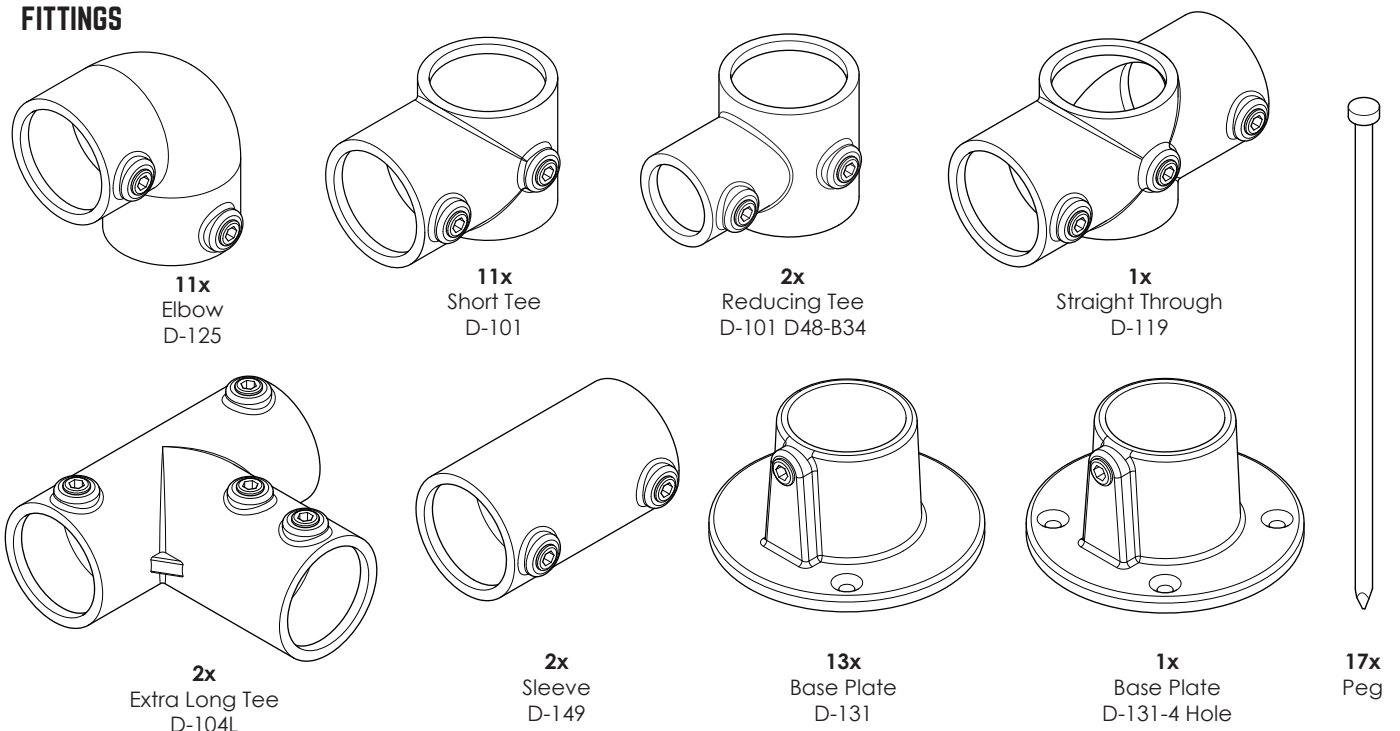

HARDWARE

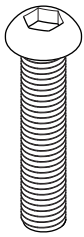

27x
M10 Bolt

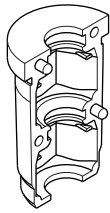

54x
Rung Insert

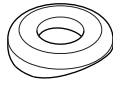

27x
Washer



54x
M10 Hex Nut

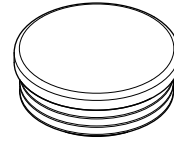

5x
Plastic End Cap



1x
Manufacture Sticker

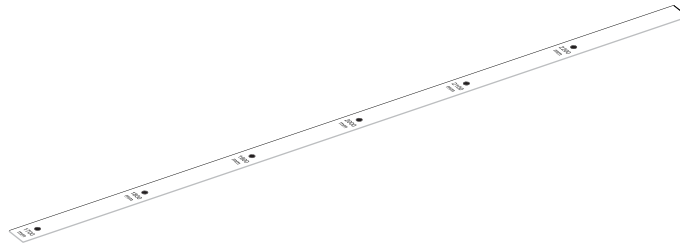

4x
Height Sticker

COMPONENTS (ACCESSORIES IF APPLICABLE)

4x
Swing Hooks



1x
Silks

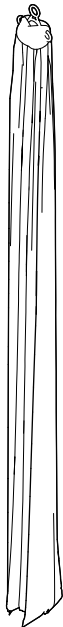

1x
Aerial Hoop

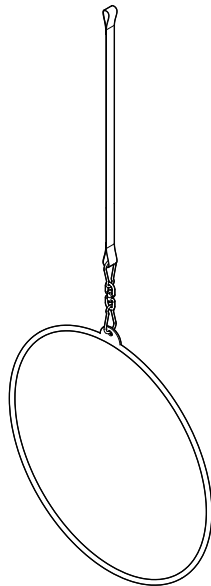

1x
Yoga Swing

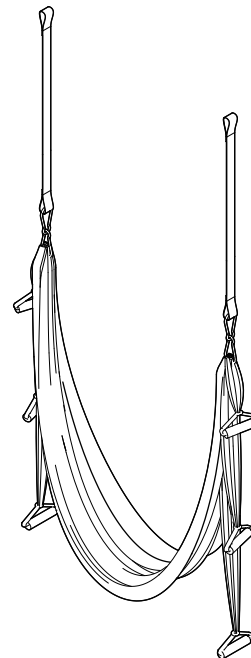

2x
Roman Rings

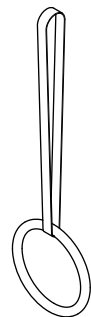

One of the best things about a Funky Monkey Bar is the ability to add new equipment and accessories as your child and family grows. You can swap or add accessories to your existing frame, or add extra frames that will give you more versatility to attach equipment. Check out what we've got in store now at...

WWW.FUNKYMONKEYBARS.COM

1 RUNG ASSEMBLY (x13)

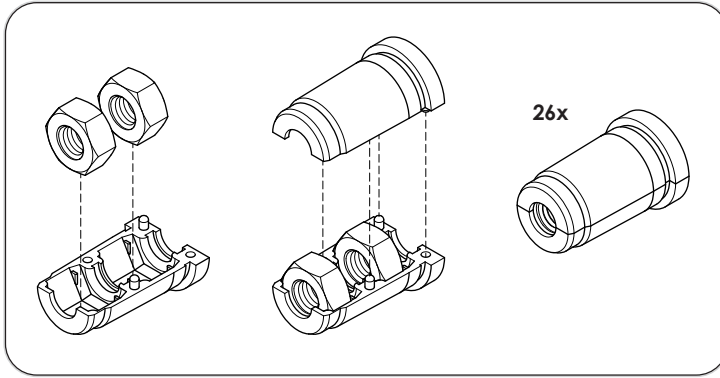

1. Assemble plastic rung inserts as shown above.

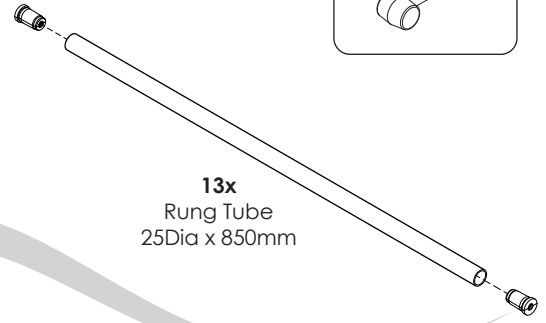
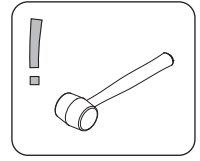

2. Push inserts into both ends of all rungs.

2 MONKEY BAR LADDER ASSEMBLY

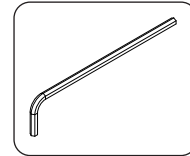
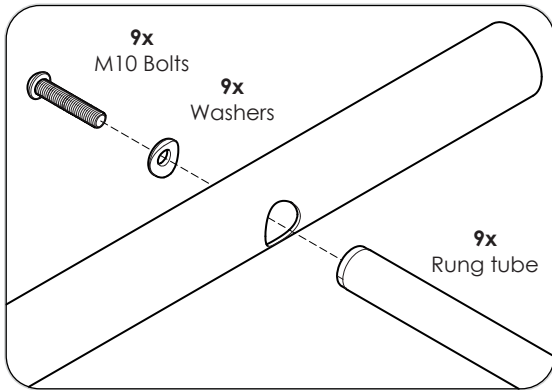

Hand tighten all bolts.

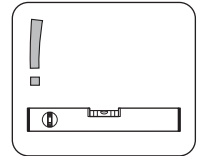

Assemble on flat surface.

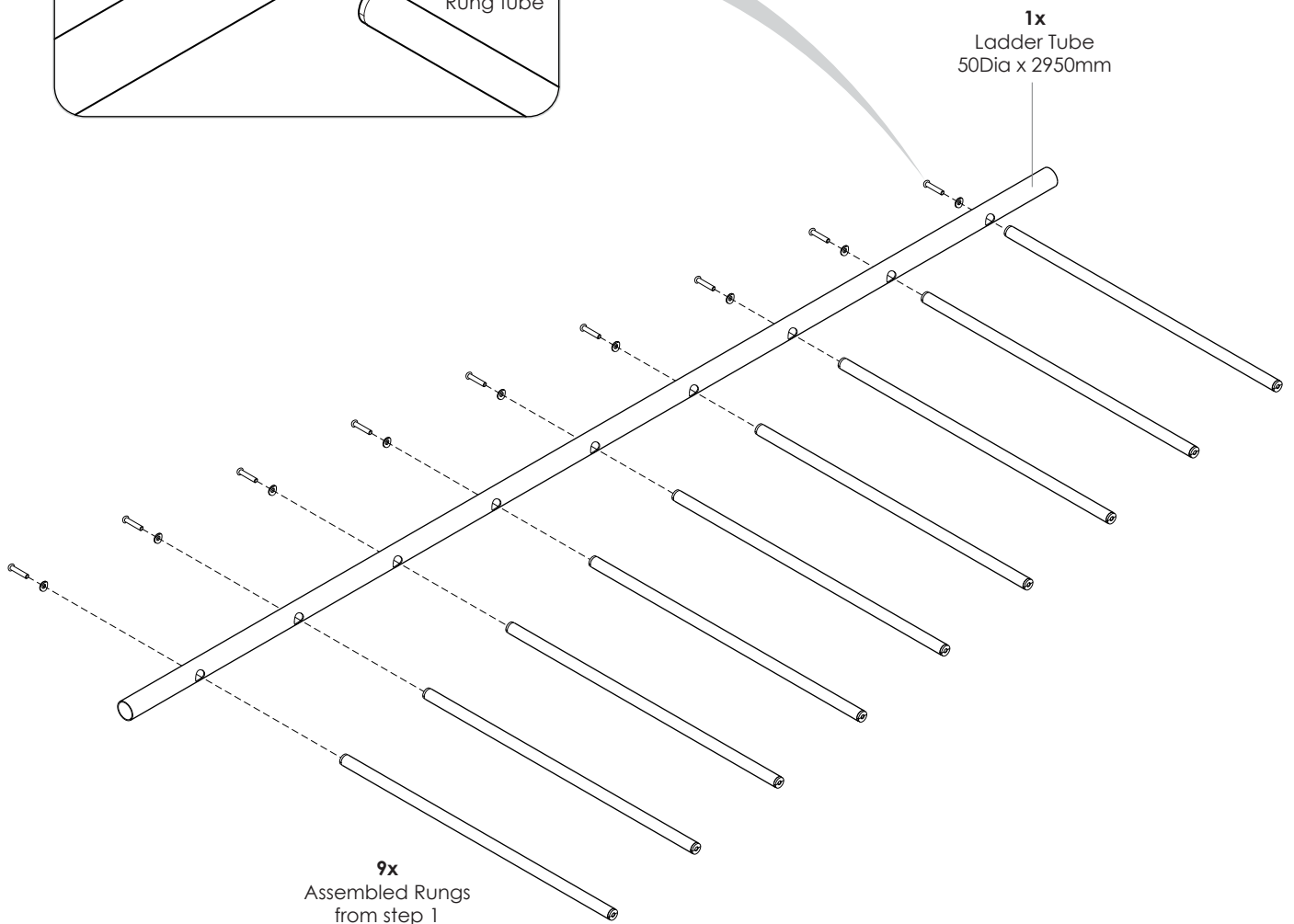

3 ATTACH SECOND LADDER TUBE

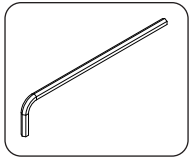

Hand tighten all bolts

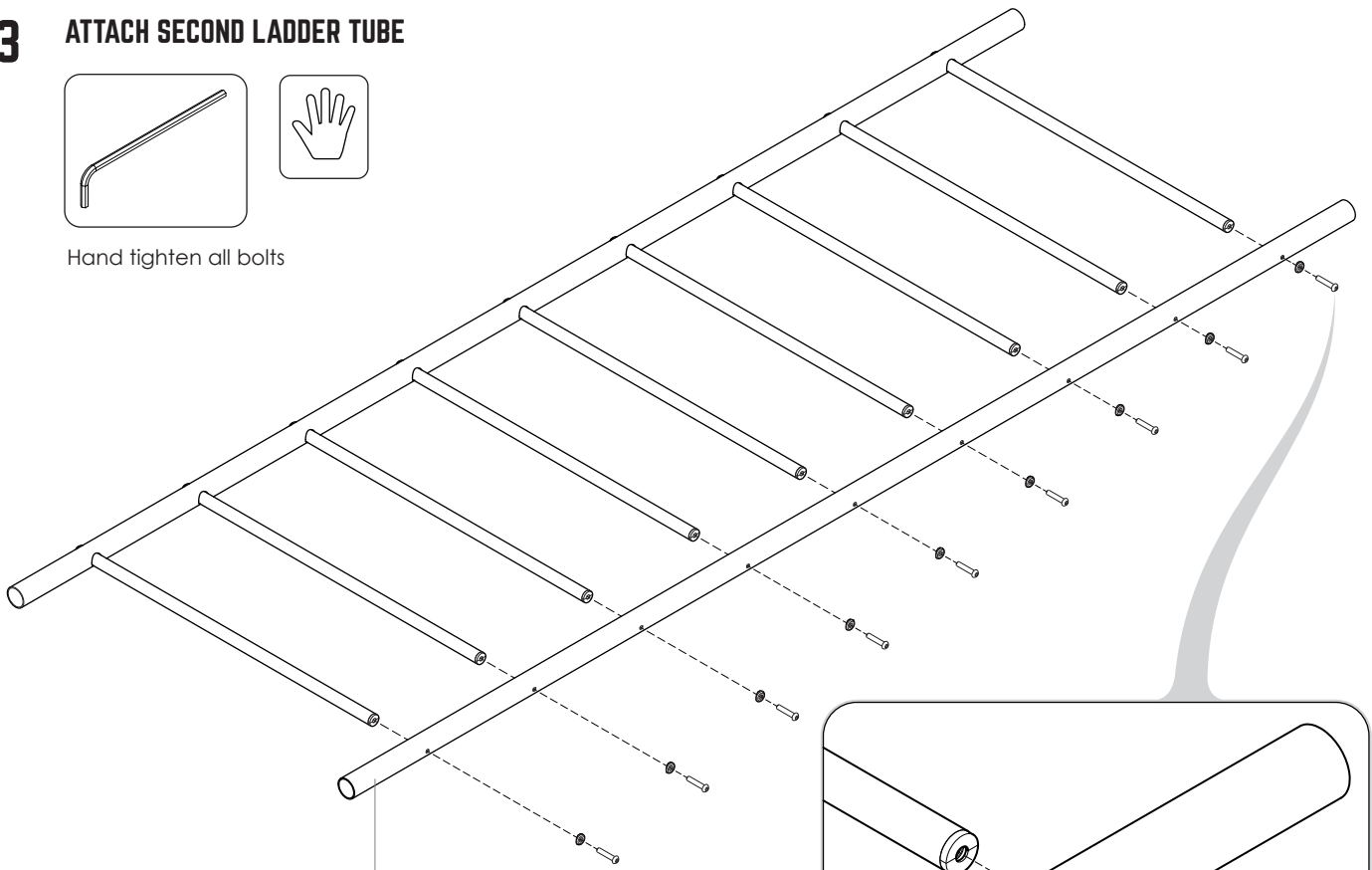

1x
Ladder Tube
50Dia x 2950mm

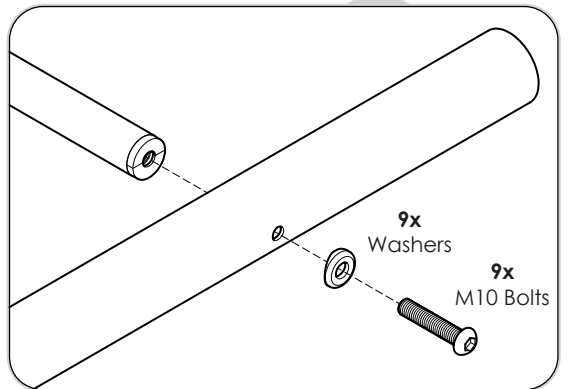

4 FIRMLY TIGHTEN ALL RUNG BOLTS.

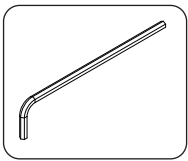

See page 5 for correct
tightening method.

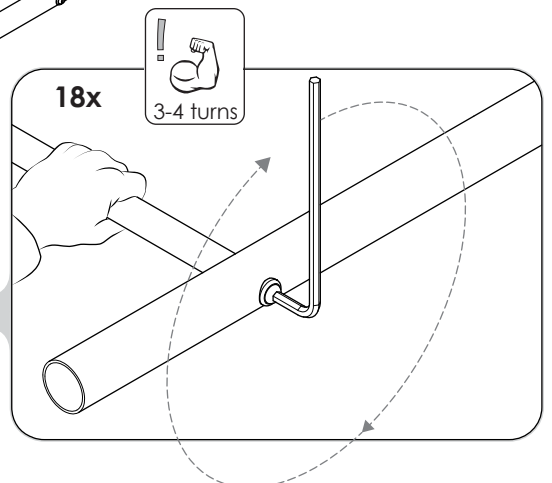
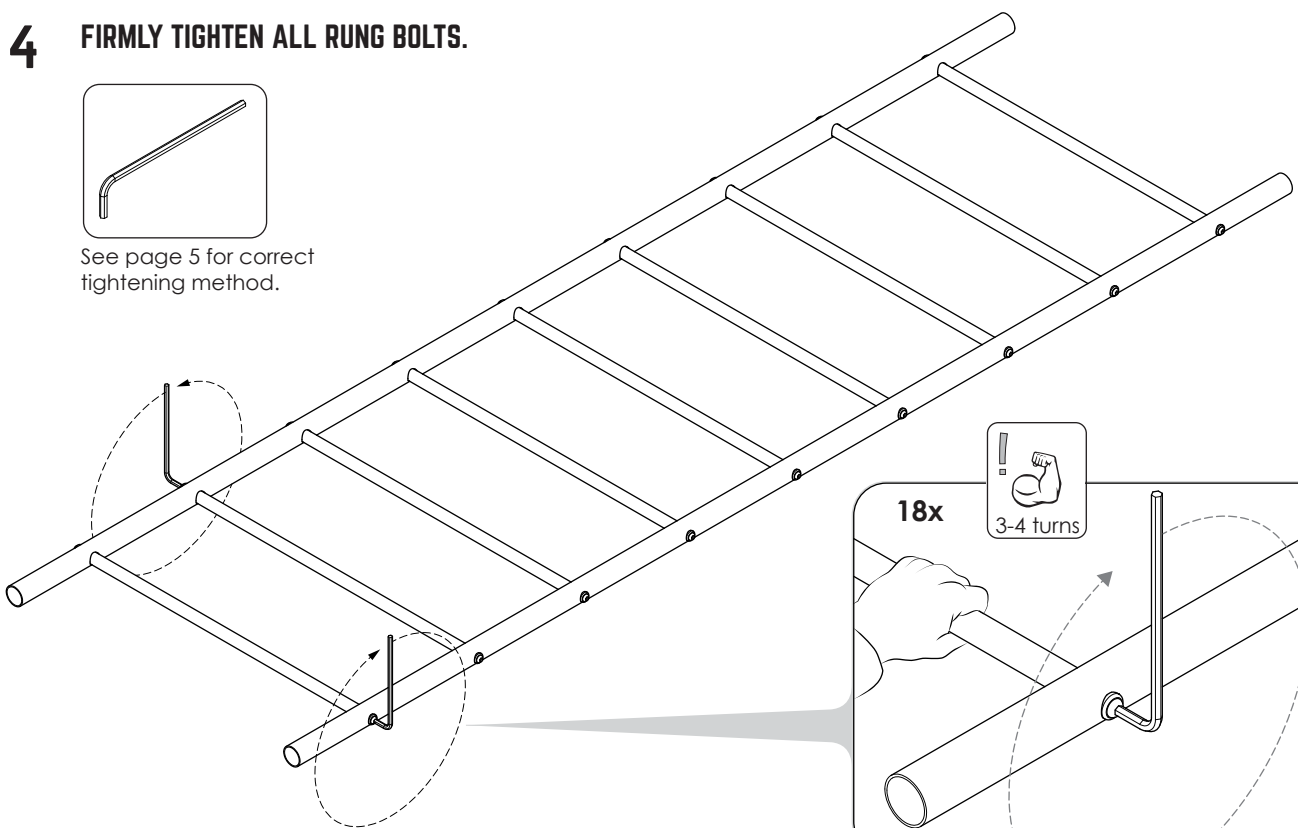

5 LEG ASSEMBLY x 2

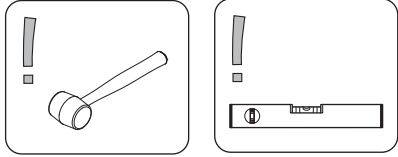

On flat level ground insert plastic end caps into leg tubes.

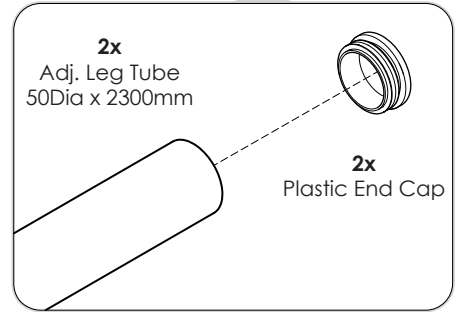
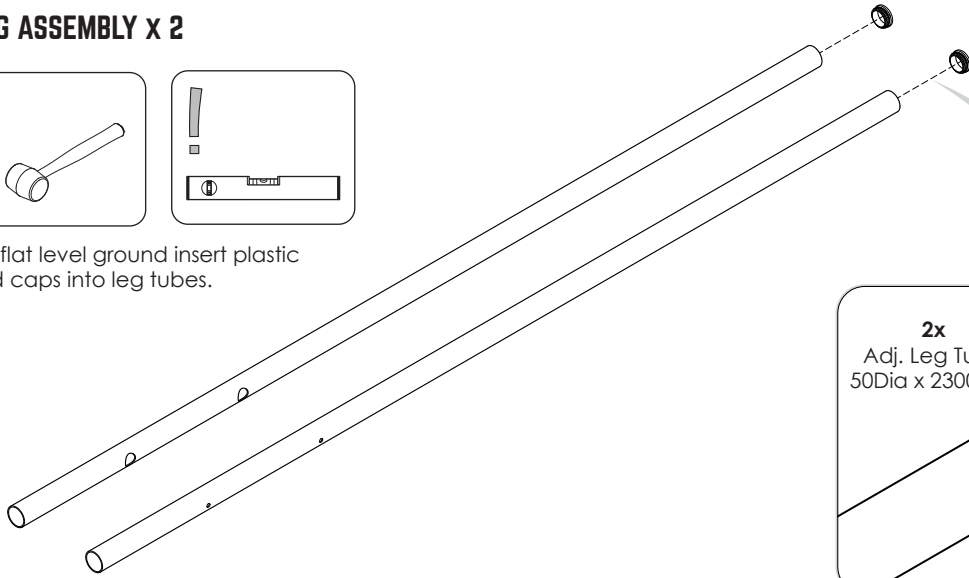

6 INSERT RUNGS

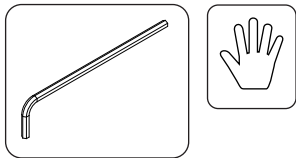

Hand tighten all bolts.

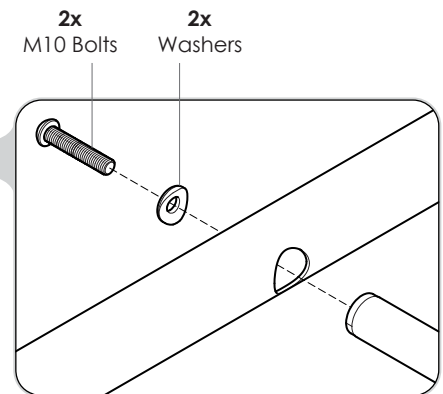
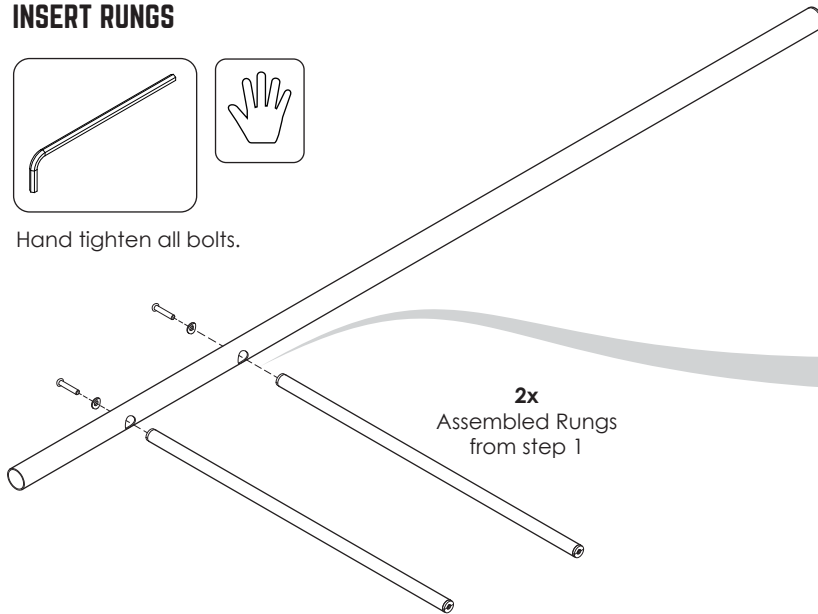

7 ATTACH SECOND LEG

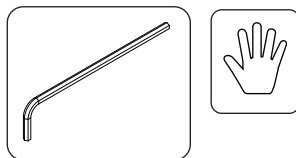

Hand tighten all bolts.

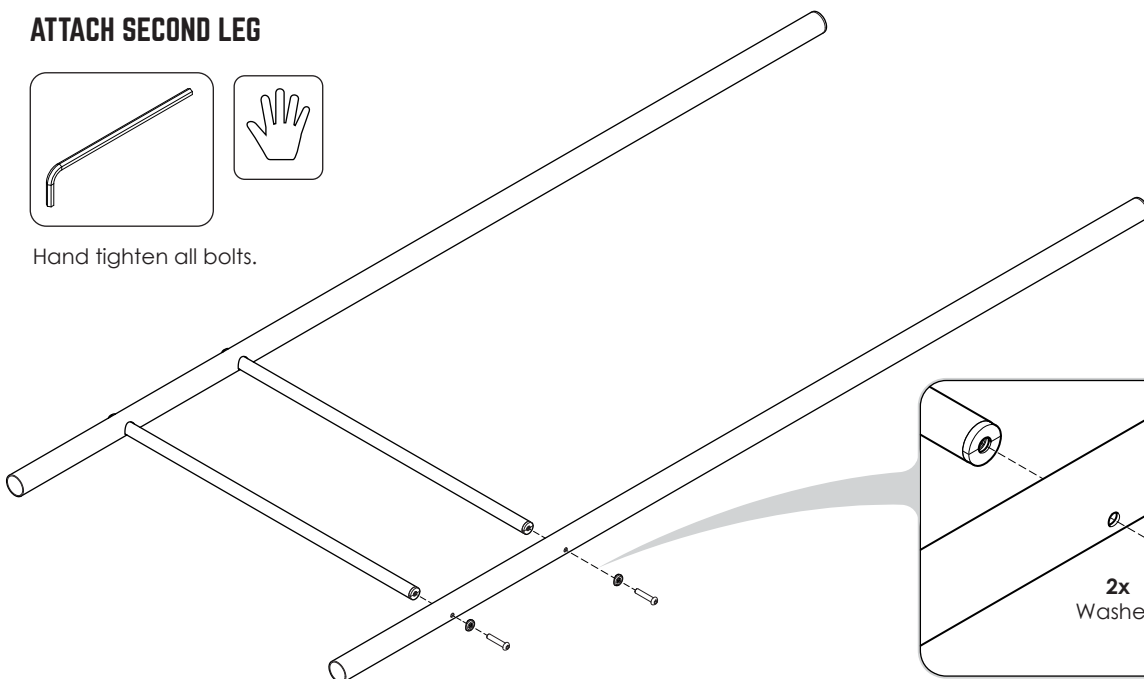

8 ATTACH BASE PLATES & SHORT T (A)

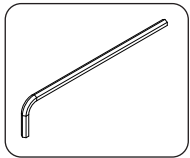

Slide on short tee (A) half way between rung and base plate.
Tighten all grub screws.

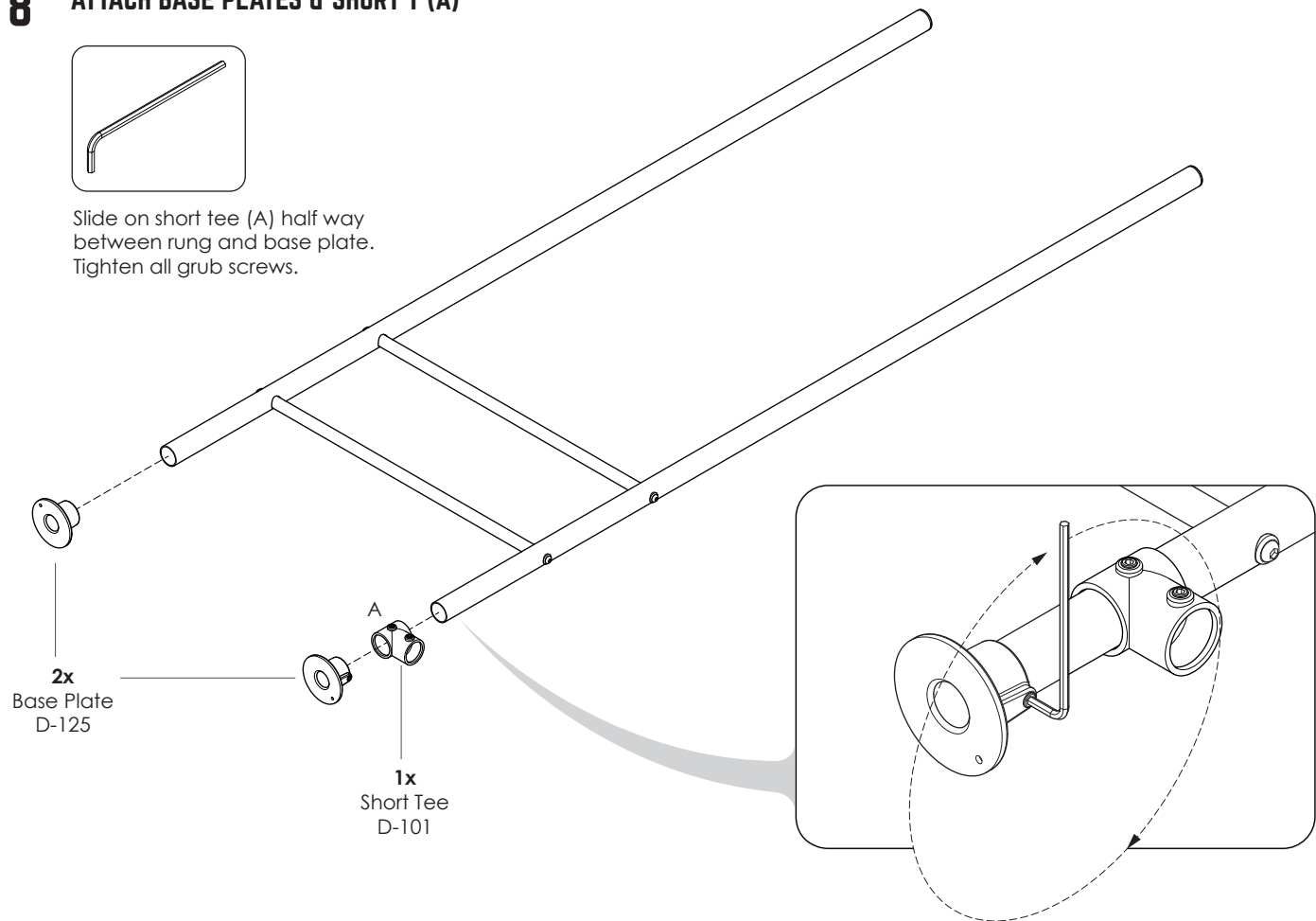

2x
Base Plate
D-125

A
1x
Short Tee
D-101

9 SLIDE ON SHORT TEE (B)

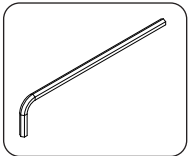

Hand tighten grub screws on
short tee (B).
Temporary location.

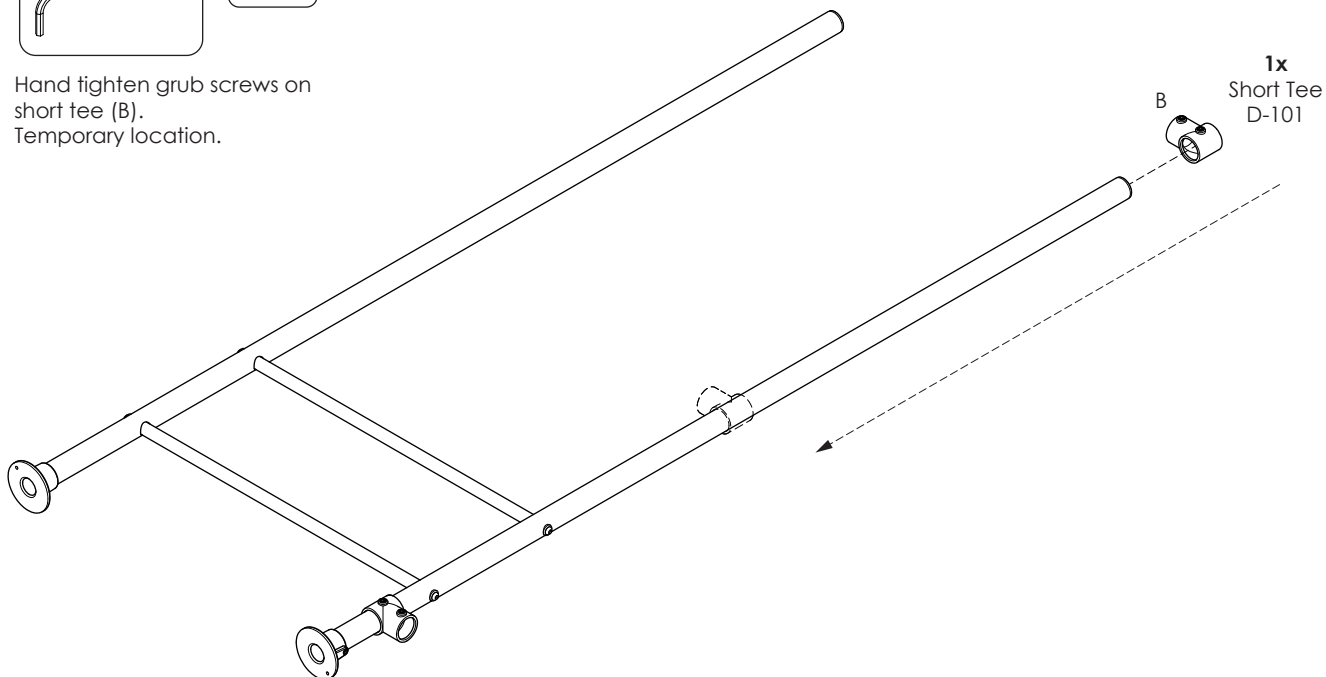

B
1x
Short Tee
D-101

10 APPLY HEIGHT STICKERS.

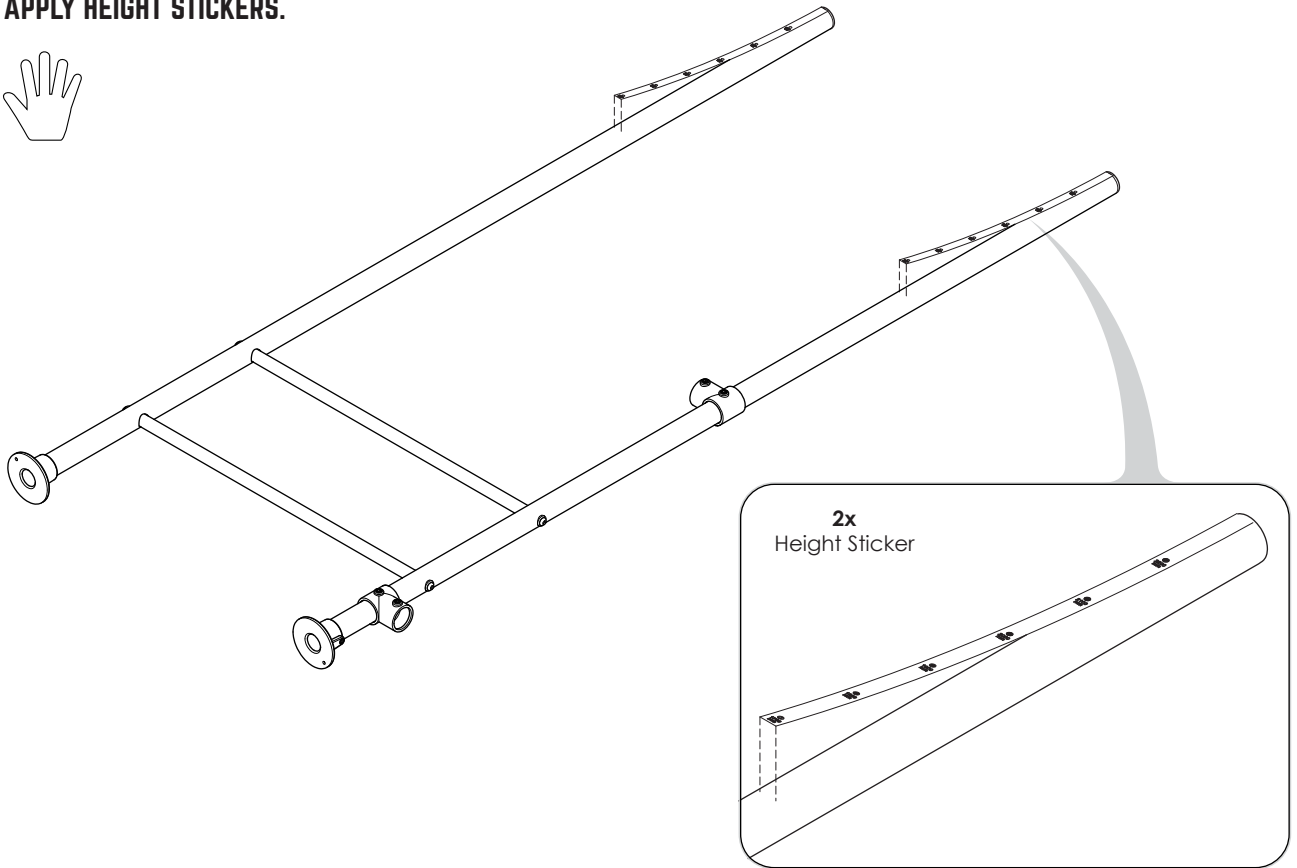

11 SET LADDER BAR HEIGHT.

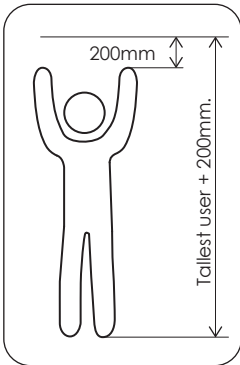

Good starting height is 100-200mm above reach.

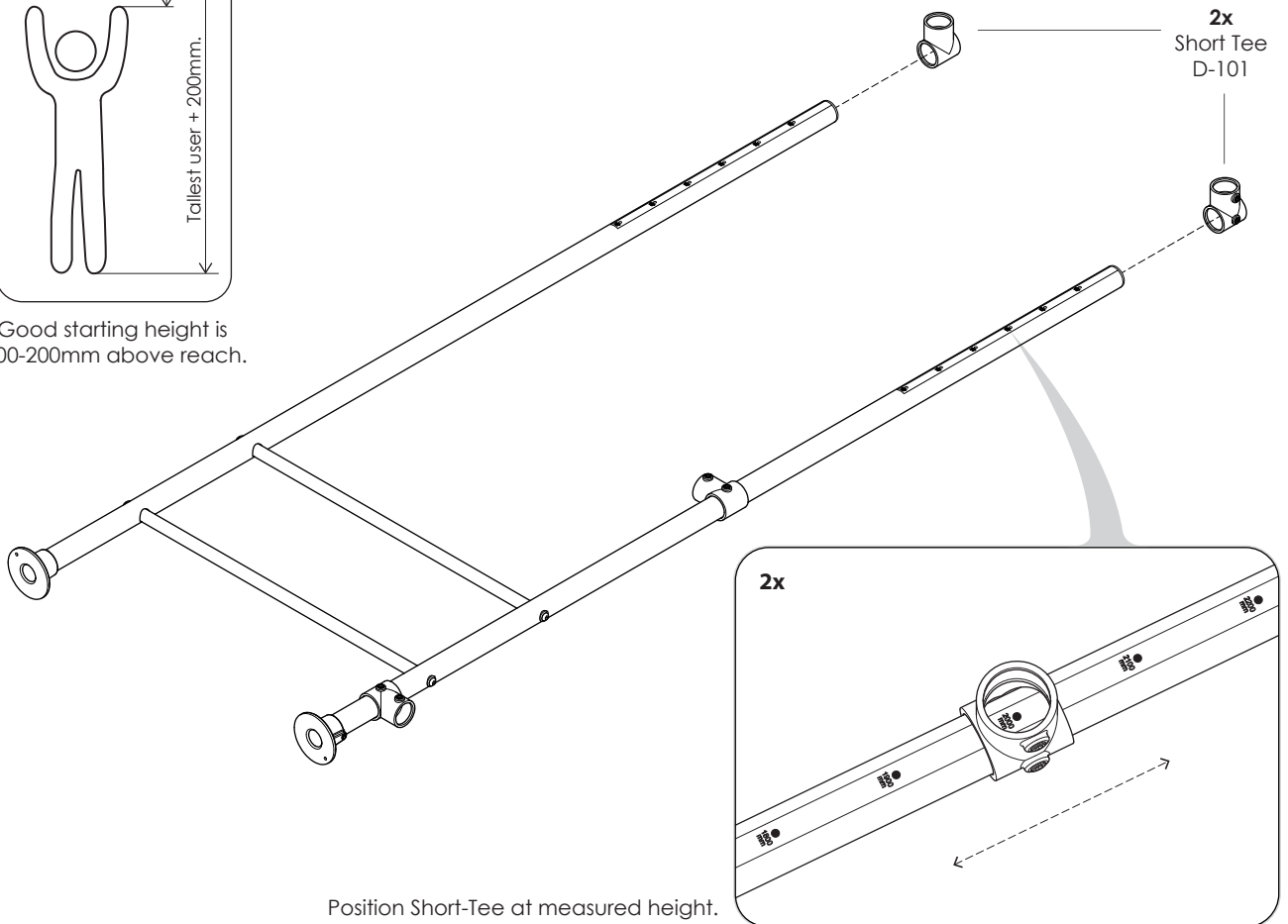

12 FIRMLY TIGHTEN ALL GRUB SCREWS & RUNG BOLTS.

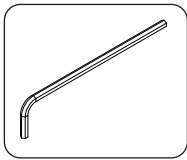

Leave grub screw B hand tight.
(Temporary location).
Fully tighten all others.

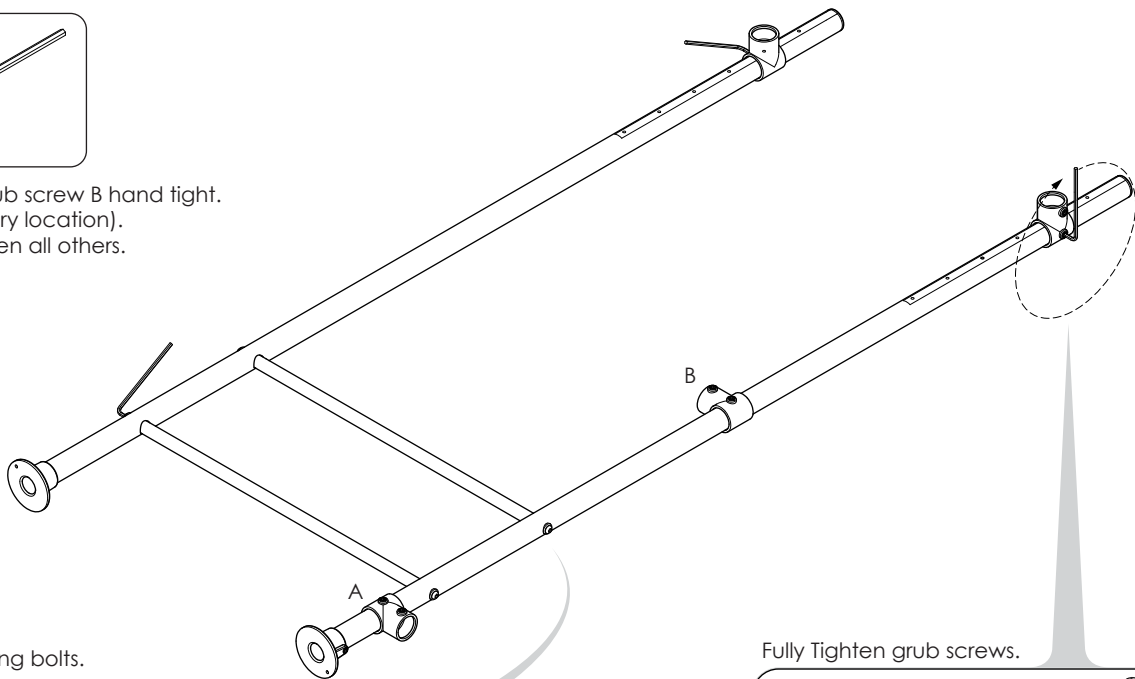

Fully Tighten rung bolts.

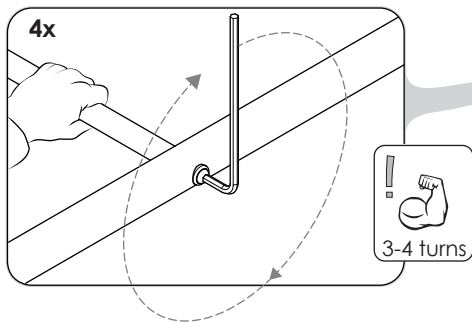

Fully Tighten grub screws.

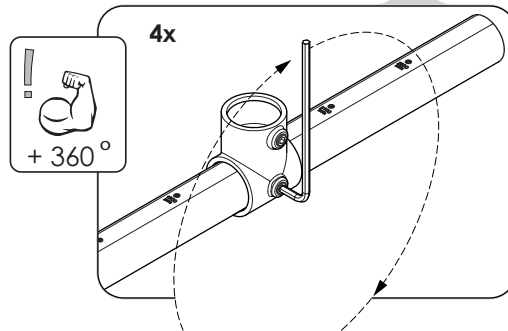

13 REPEAT STEPS 5-12 FOR 1 MORE LEG ASSEMBLY. SAME PROCEDURE BUT WITHOUT SHORT TEE A & B. ADD REDUCING TEE (C) - (SEE STEP 14 FOR FINAL RESULT)

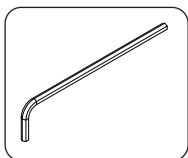

Position reducing tee (C) at
desired chin up bar height.
Fully tighten all grub screws.

NOTE: position of (C) could
be above short tees depending
on user height preferences.

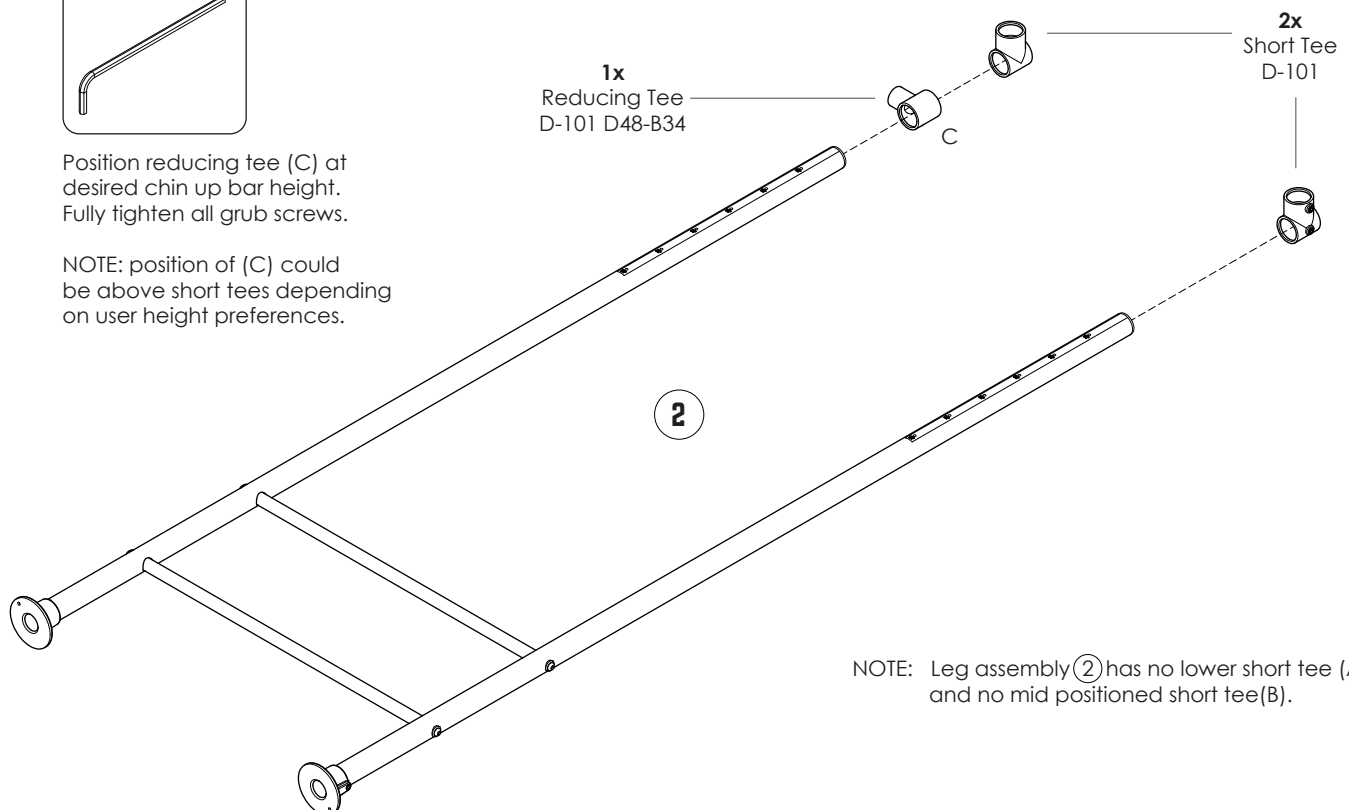

NOTE: Leg assembly ② has no lower short tee (A)
and no mid positioned short tee (B).

14 LEG ASSEMBLY X2.

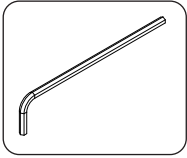

Tighten all grub screws.

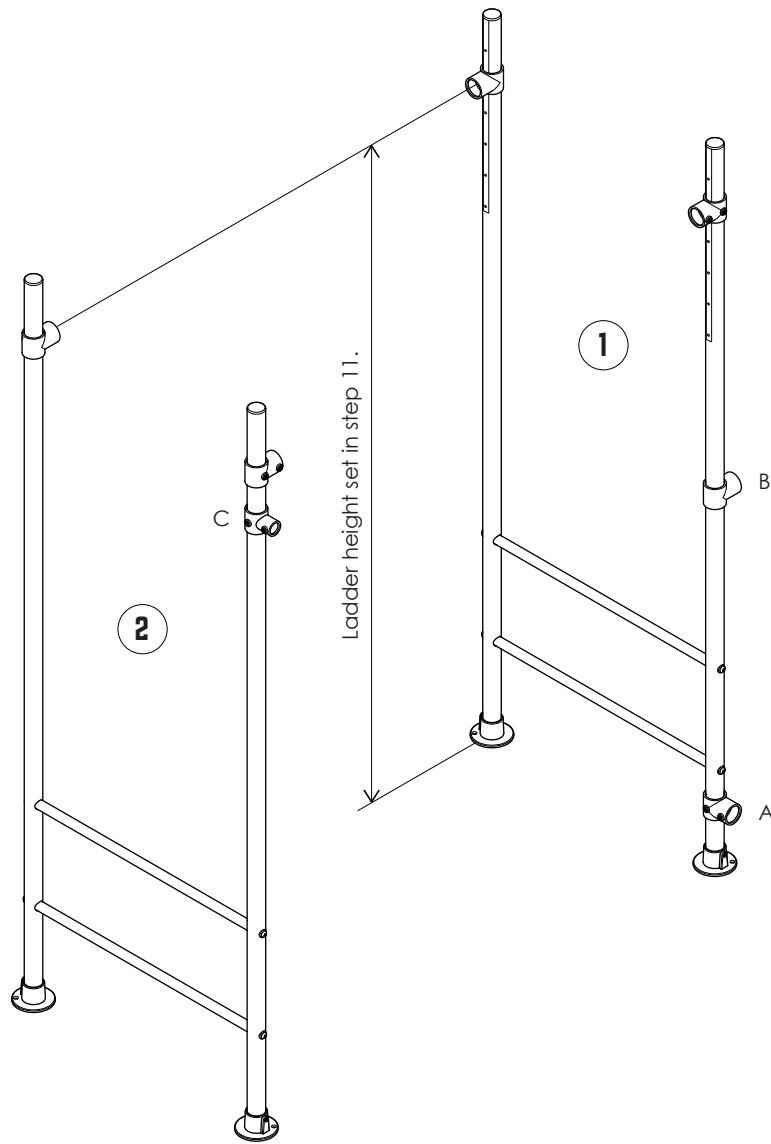

15 CHECK ALL FITTING GRUB SCREWS AND RUNG BOLTS ARE FULLY TIGHTENED

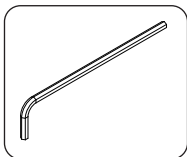

Firmly tighten all grub screws and bolts,
Leave short tee B hand tight for later adjustment.

16 ASSEMBLE VERTICAL TWIRLY TUBE

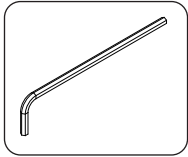

Tighten all grub screws.

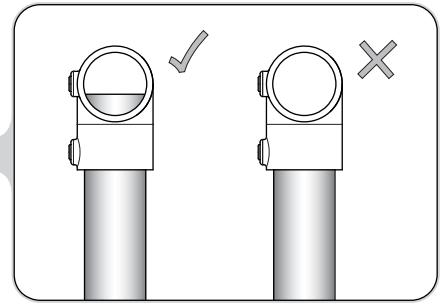
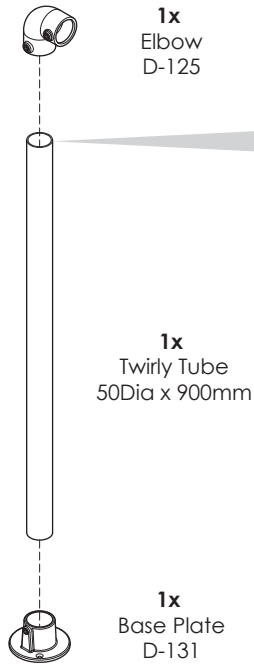

Insert Twirly Tube fully into Elbow.

17 ATTACH HORIZONTAL TWIRLY TUBE

Fully insert twirly tube then firmly tighten all grub screws.

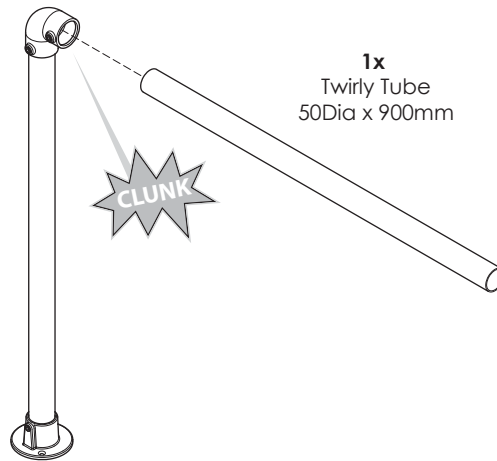
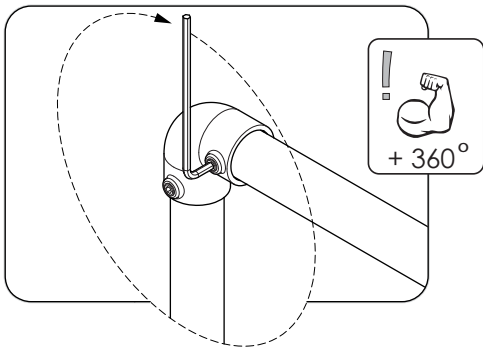

18 REPEAT STEPS 16 - 18 FOR 3 MORE TWIRLY WHIRLY BARS.

19 TWIRLY WHIRLY BAR x4

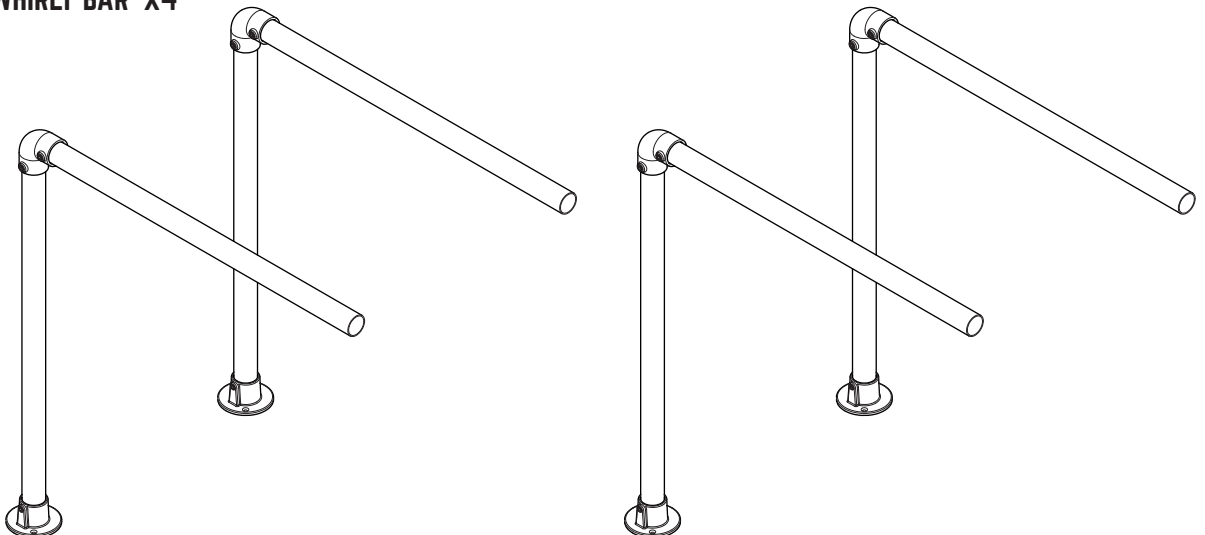

20 FLIP LEGS 1 & 2 OVER

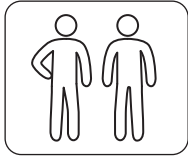

For the following step the legs should be flipped over & attached one at a time.

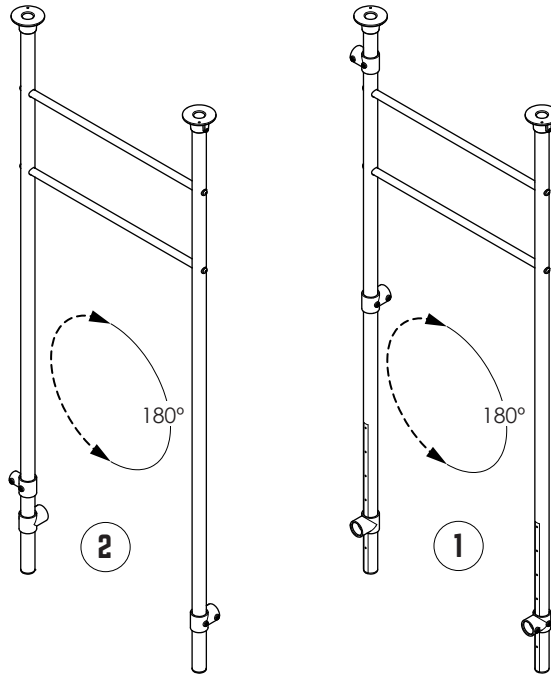

21 ATTACH 2X LEGS TO LADDER

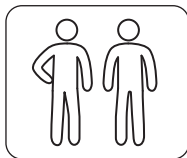
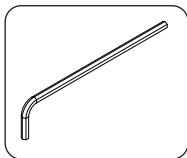

1. Attach first set of legs ① - tighten all grub screws.
2. Attach second set of legs ② - tighten all grub screws.

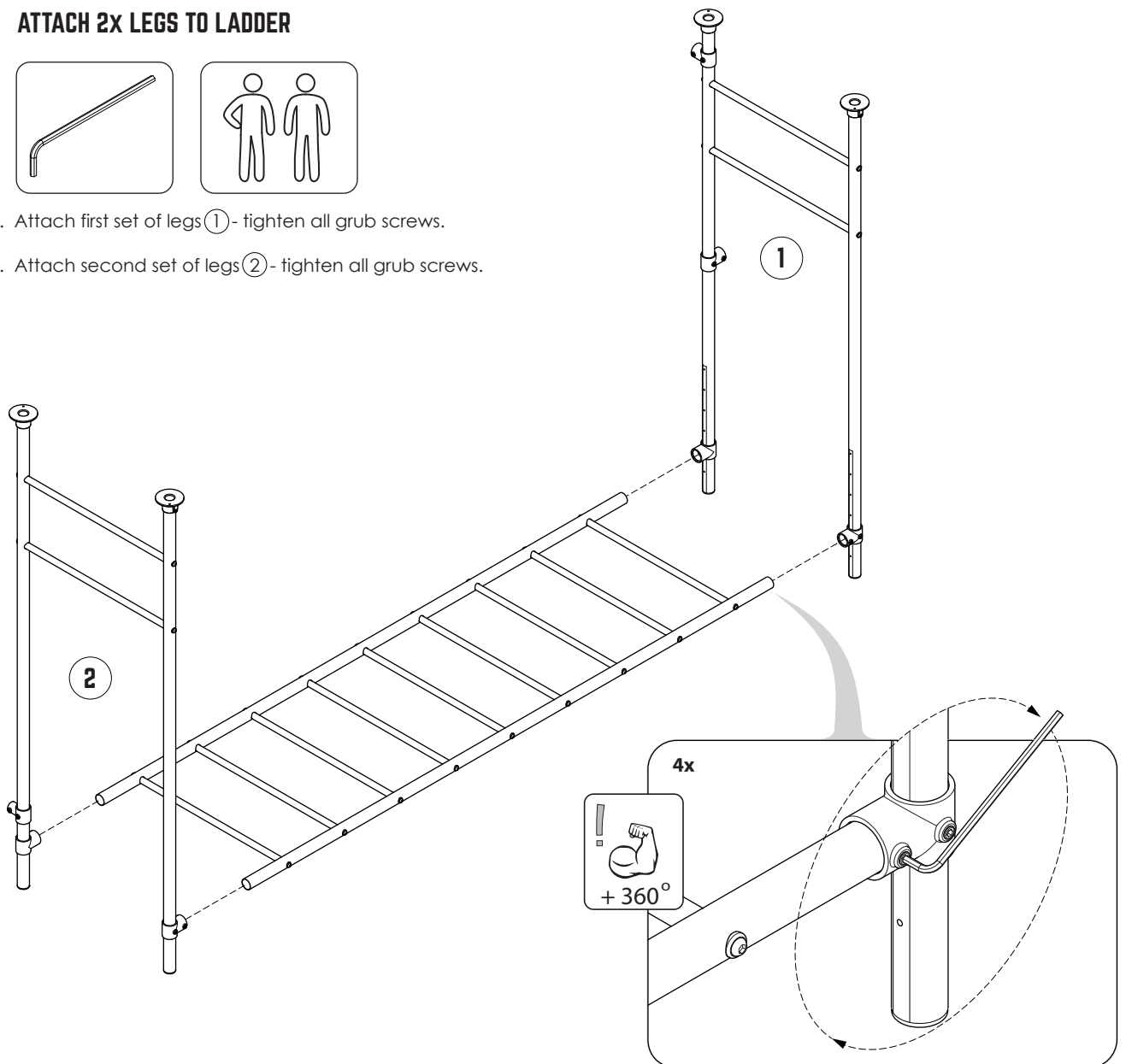

22 FLIP ASSEMBLY OVER

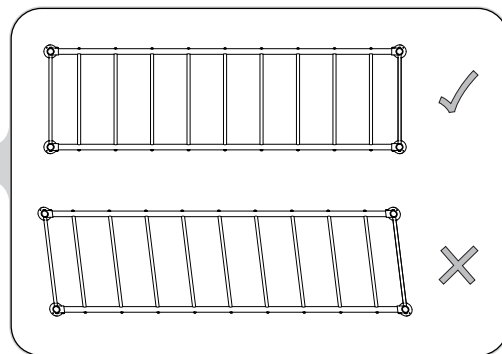
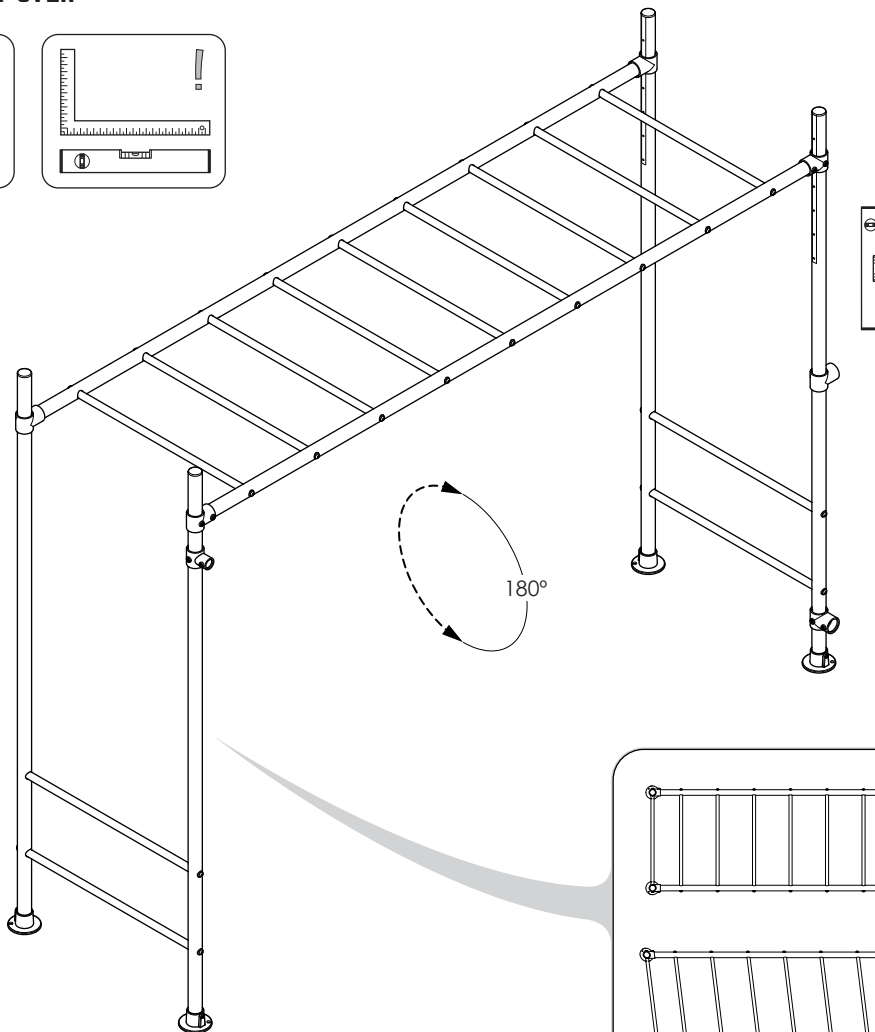
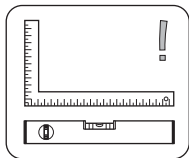
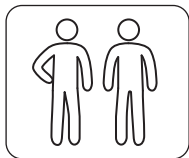

CRITICAL : ENSURE YOUR FRAME IS 100% SQUARE AND LEVEL (AS PER PAGE 6) BEFORE MOVING ON TO THE REST OF THE ASSEMBLY

23 SECURE TO GROUND

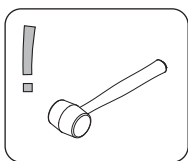

Select suitable location.
Hammer in pegs x4.

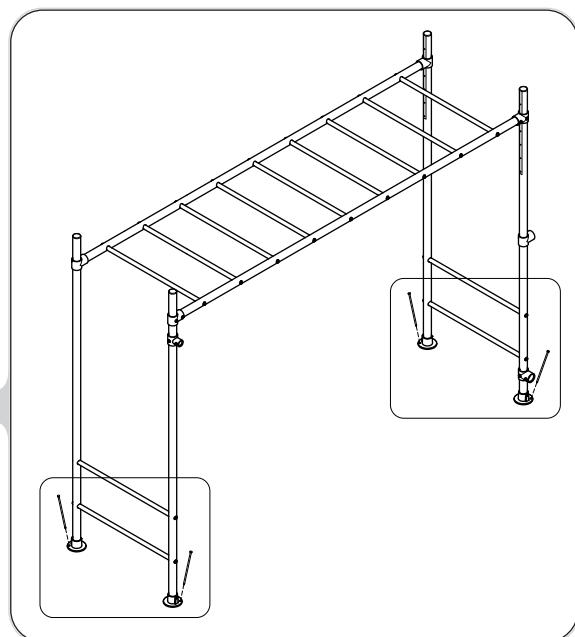
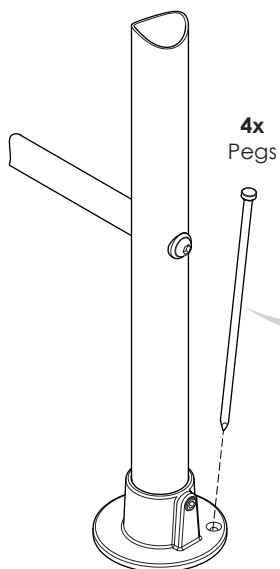

24 ASSEMBLE DIP STATION LEGS

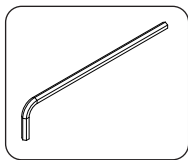

1. Fit short tees at same height as leg short tee (A) in step 8.
2. Fully insert elbows and base plates, then fully tighten all grub screws.

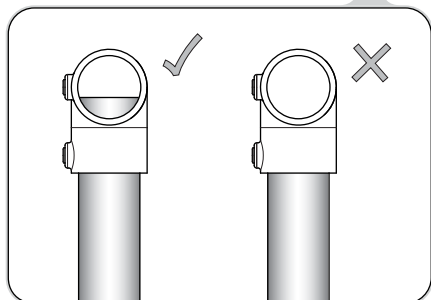

Insert Twirly Tube fully into Elbow.

1

2

3

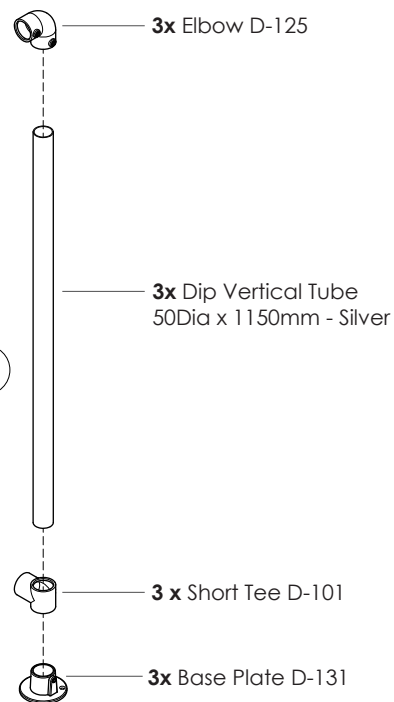

25 ATTACH DIP STATION LEG 1 & DIP BAR

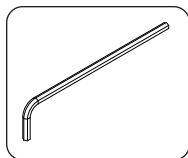

Fully insert all fixings. Adjust height of short tee on leg & check it is level and square.

1x Dip Horizontal Tube 50Dia x 1150mm - Black

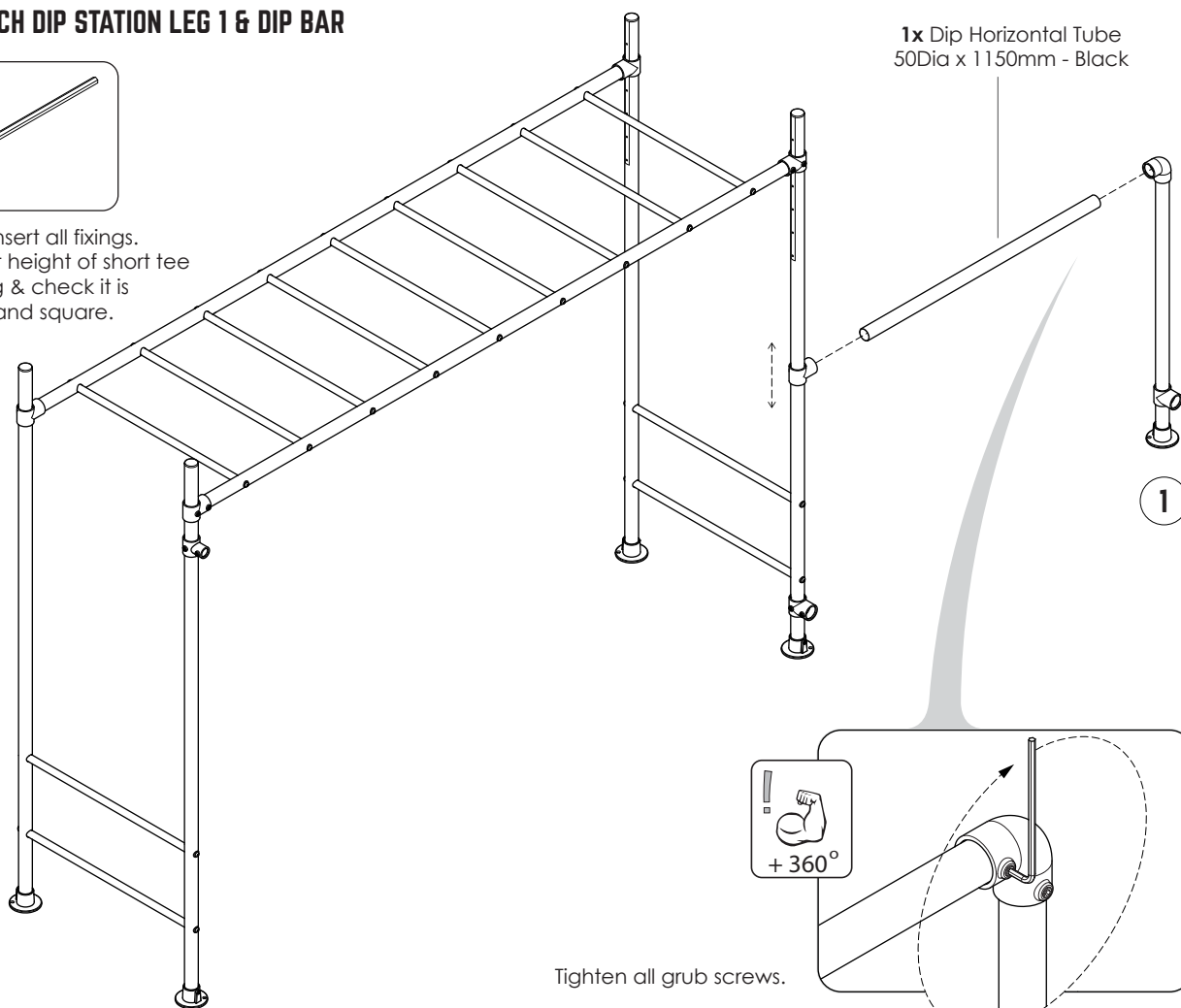

1



Tighten all grub screws.

26 ASSEMBLE OTHER DIP STATION SIDE

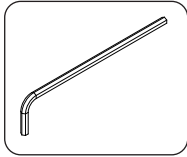

On flat level ground insert brace and black dip tubes into dip station legs 2&3. Firmly tighten all grub screws.

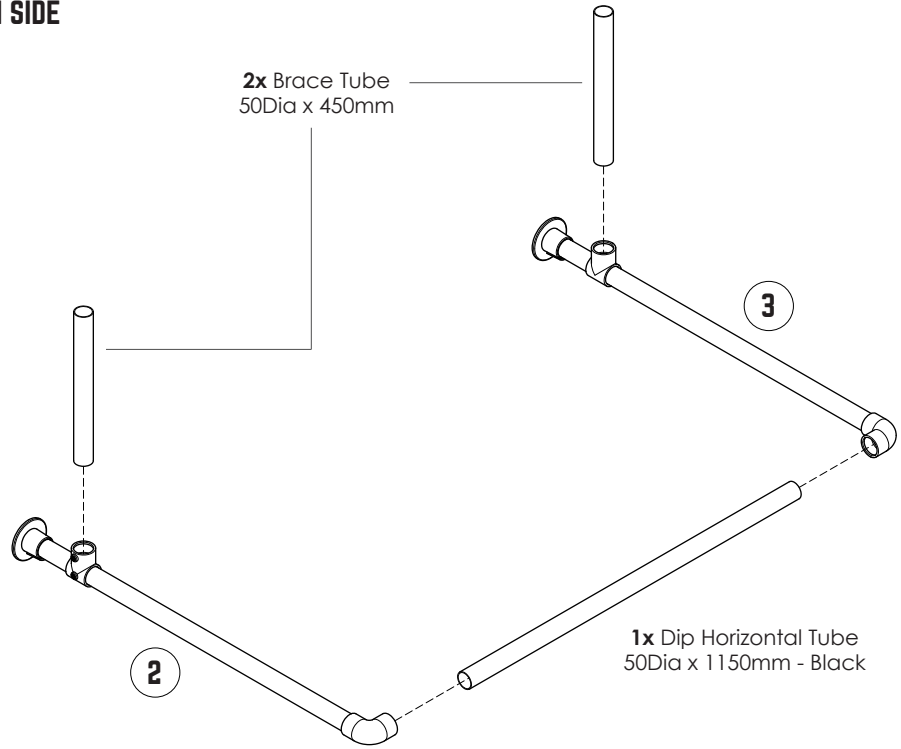

27 ATTACH OTHER DIP STATION SIDE

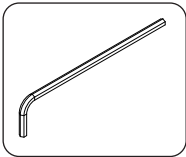

Insert brace tubes into short tees and fully tighten all grub screws on dip station.

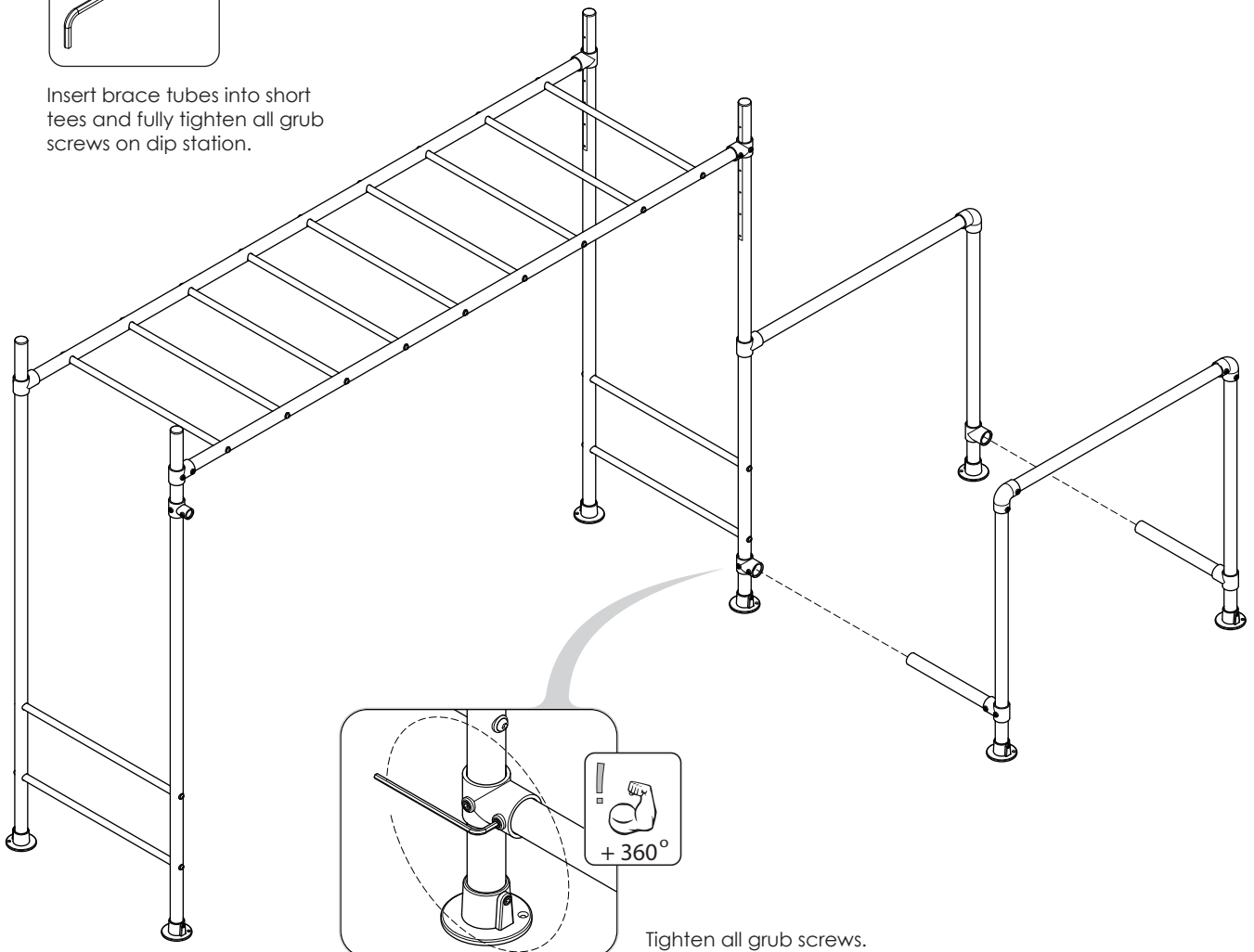

28 ASSEMBLE GYM BAR

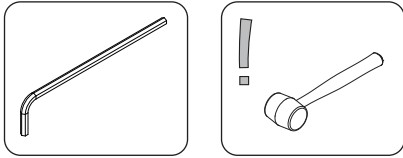

On flat level ground slide fittings onto gym leg tube. Ensure reducing tee is same height as on main frame, then fully insert chin up bar. Tap in end cap. Fully tighten all grub screws.

Ensure 4 hole base plate.

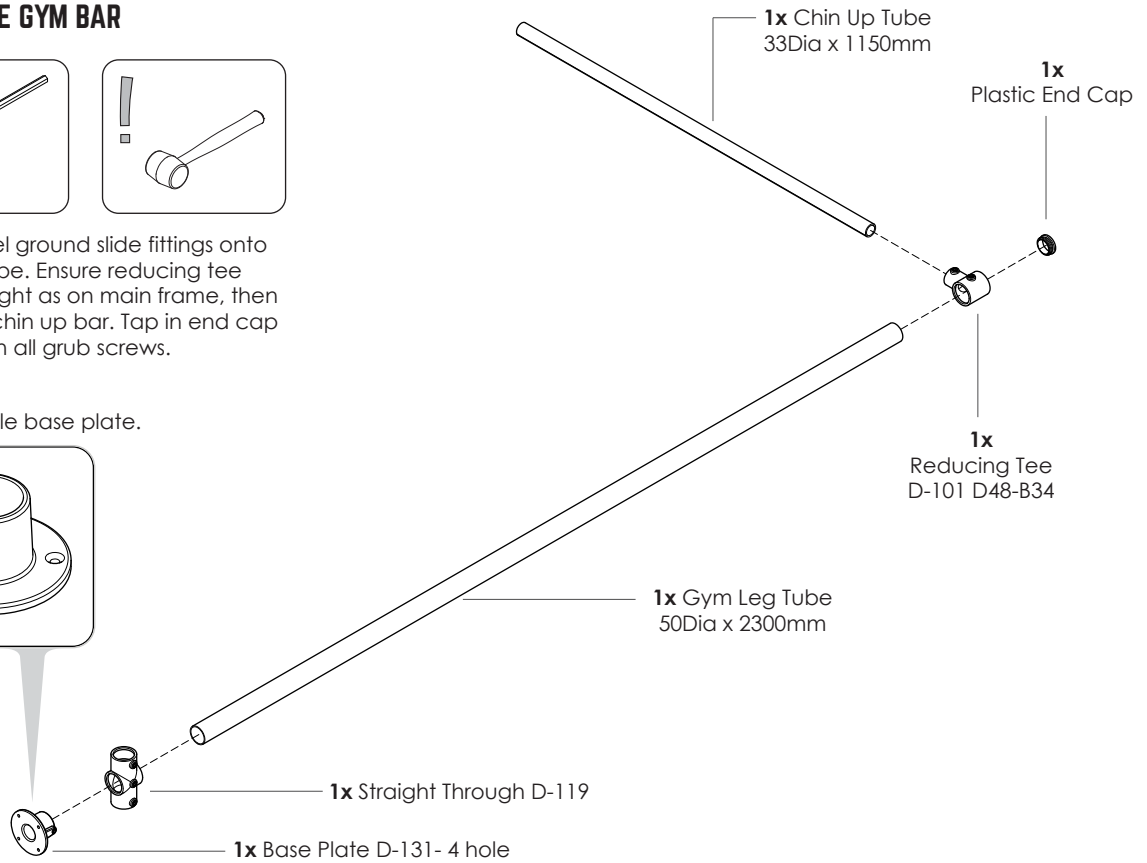
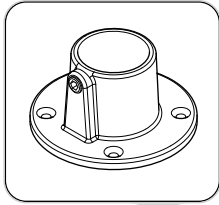

29 ATTACH GYM BAR

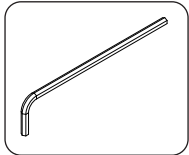

Insert gym bar tube into the reducing tee on the main monkey bar leg. Ensure gym bar is level and fully tighten all fixings.

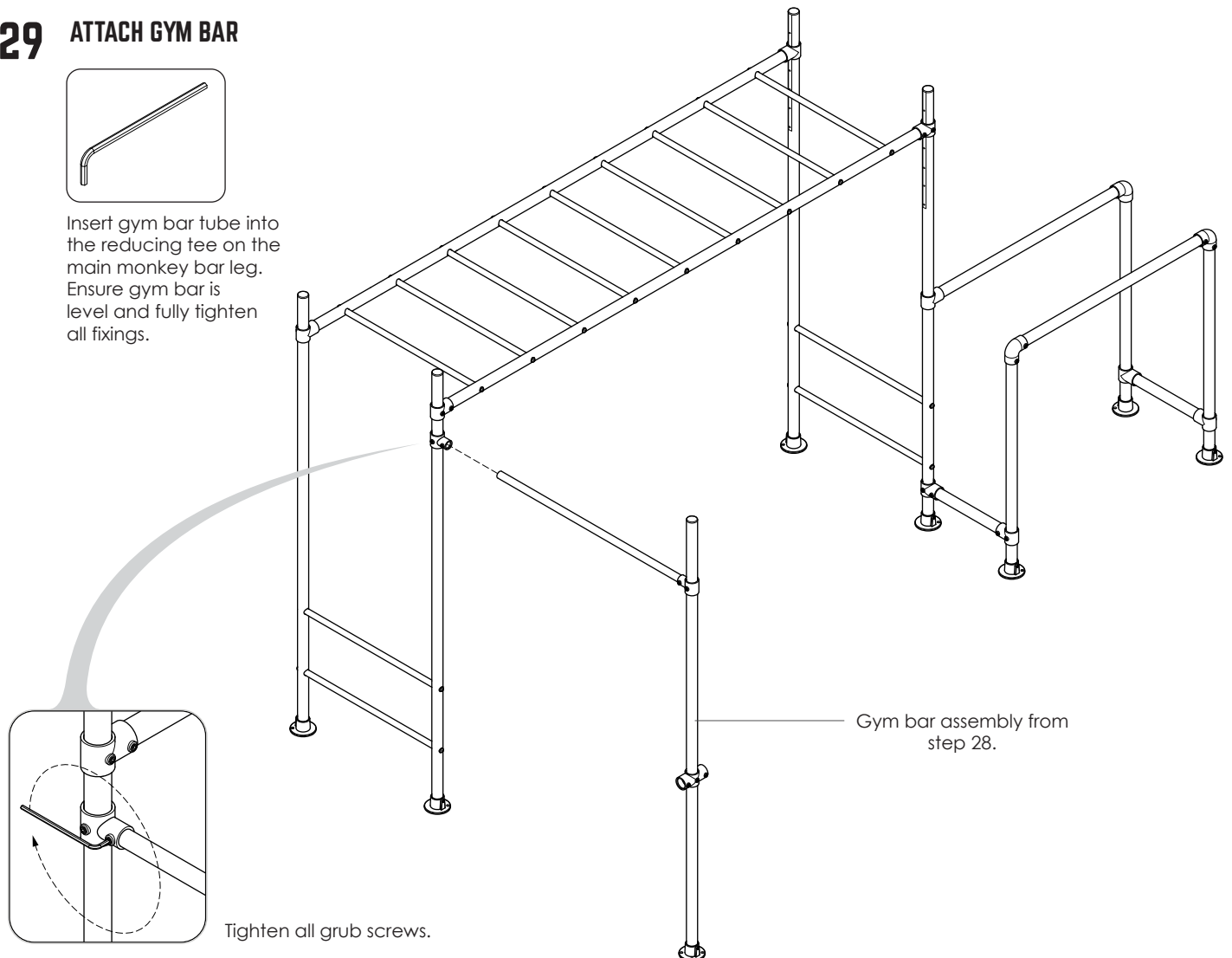

30 SECURE TO GROUND

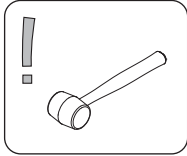
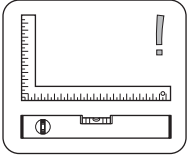

1. Check level and square - Loosen and adjust if not.
2. Hammer in pegs 7x.
3. Check all fixings are fully tight.

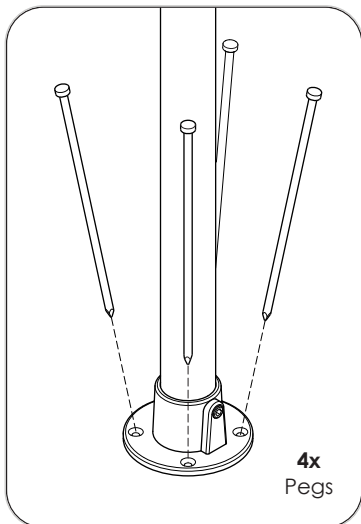
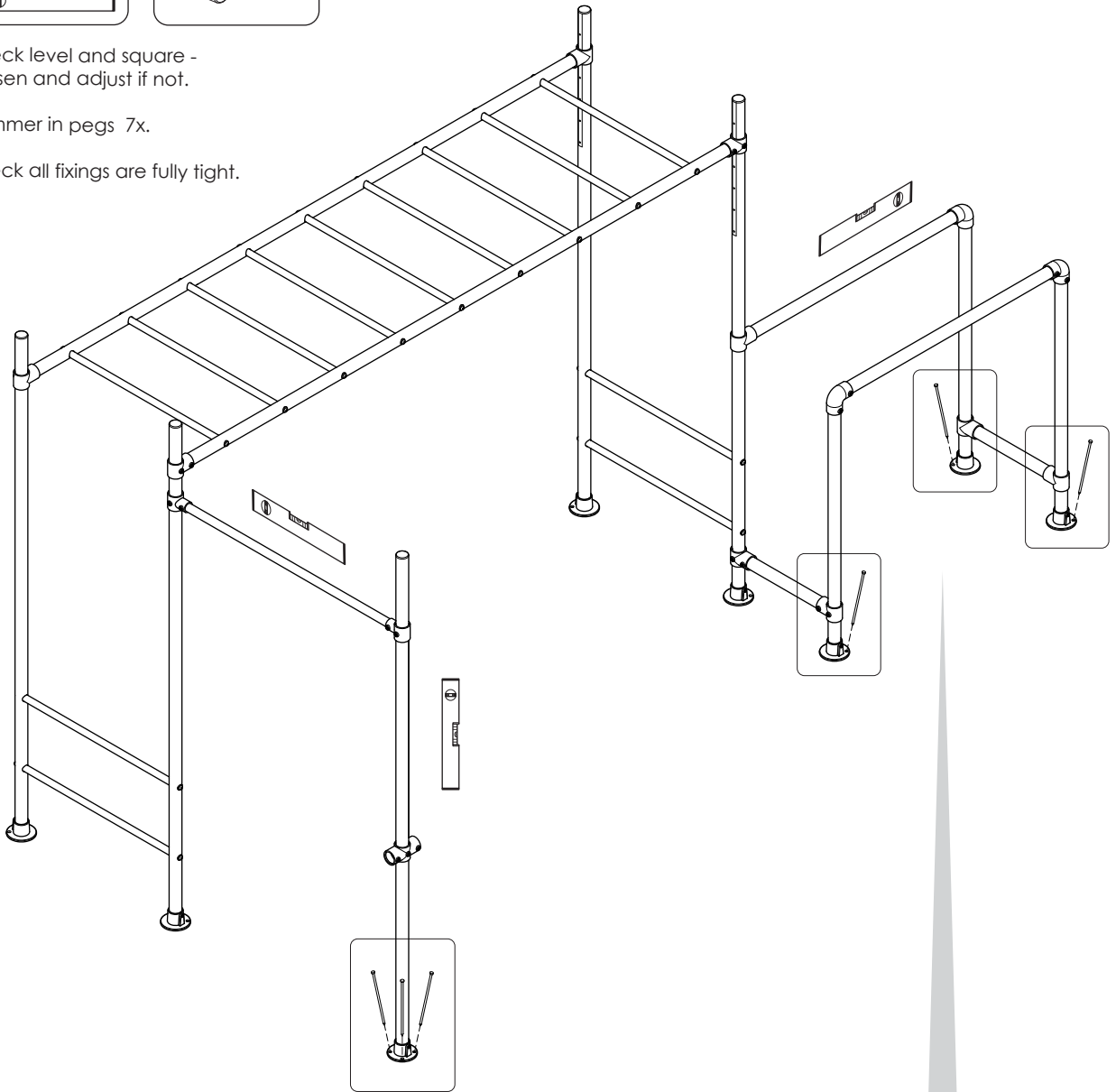

Four pegs for gym bar base plate.

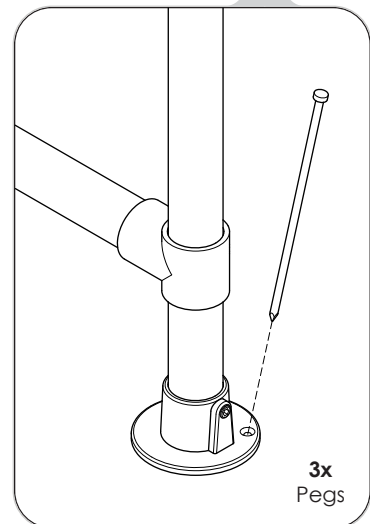

Single pegs for dip station base plates.

31 ASSEMBLE EXTENSION TUBES

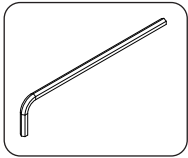

1. Insert extension tubes half way into sleeves and fully tighten grub screws.
2. Fully insert elbows onto extension tubes and leave grub screws loose.

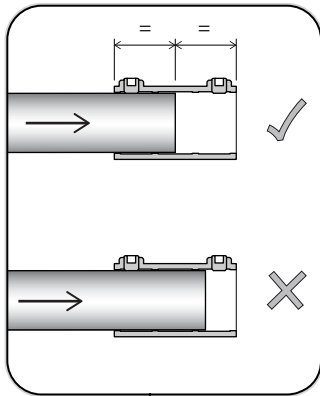
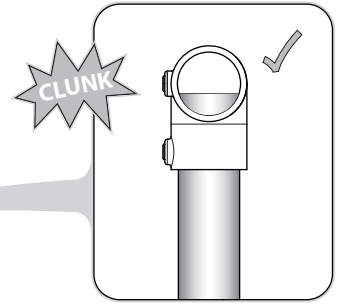

2x
Elbow
D-125

2x
Extender Tube
Dia 50 x 650mm

2x
Sleeve
D-149

32 ATTACH EXTENSION TUBES TO FRAME LEGS X2.

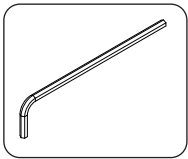

1. Slide extension tube assembly from step 31 onto frame legs. Fully tighten grub screw on sleeve.

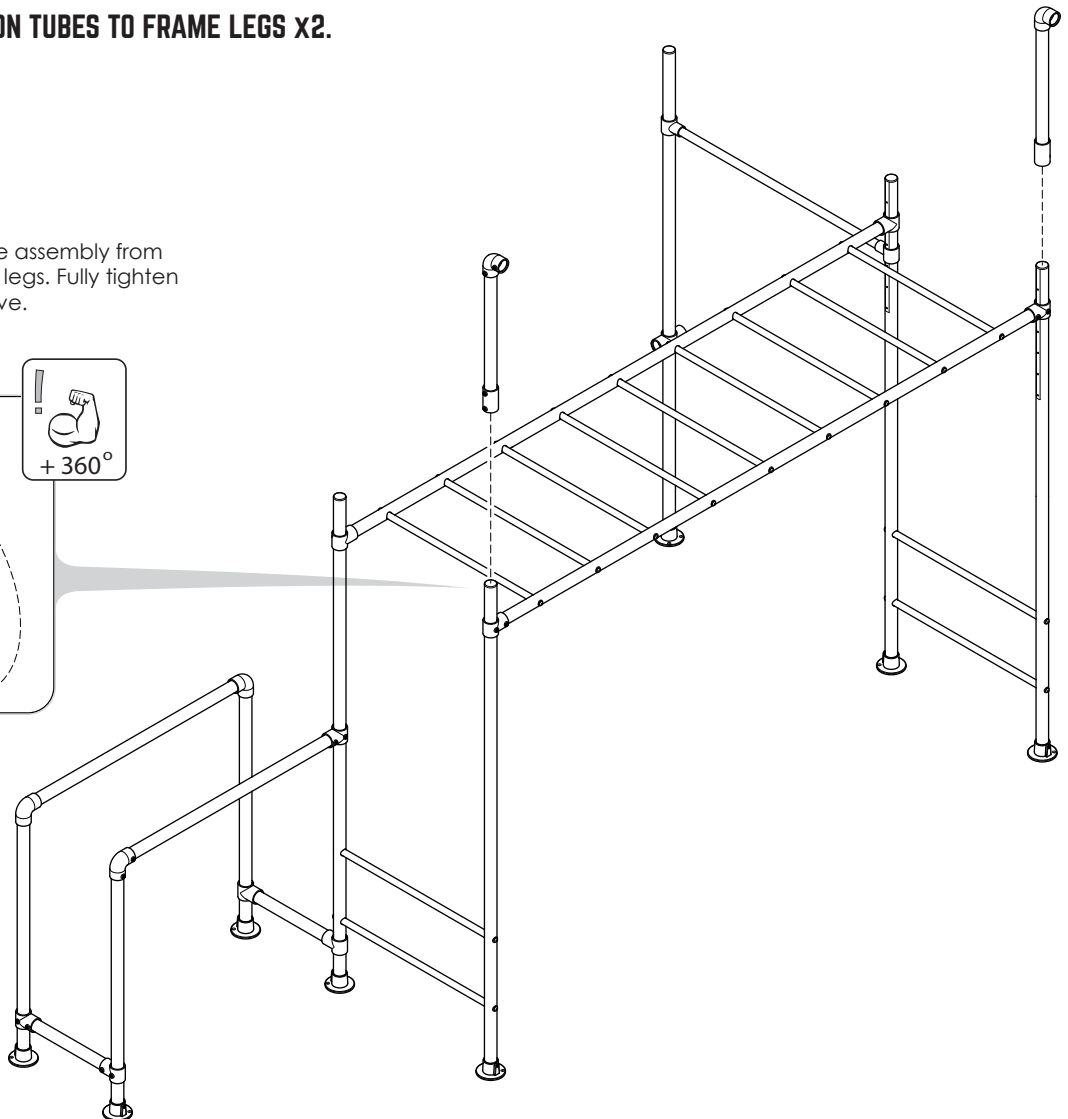
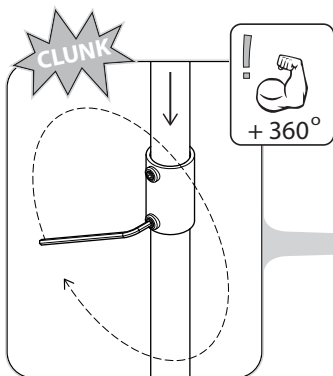

33 ASSEMBLE 2x 3M LEGS

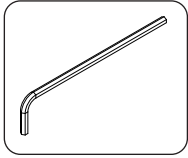

Fully insert short tees, base plates and elbows onto accessories tube.
Leave short tees loose and firmly tighten all other grub screws.

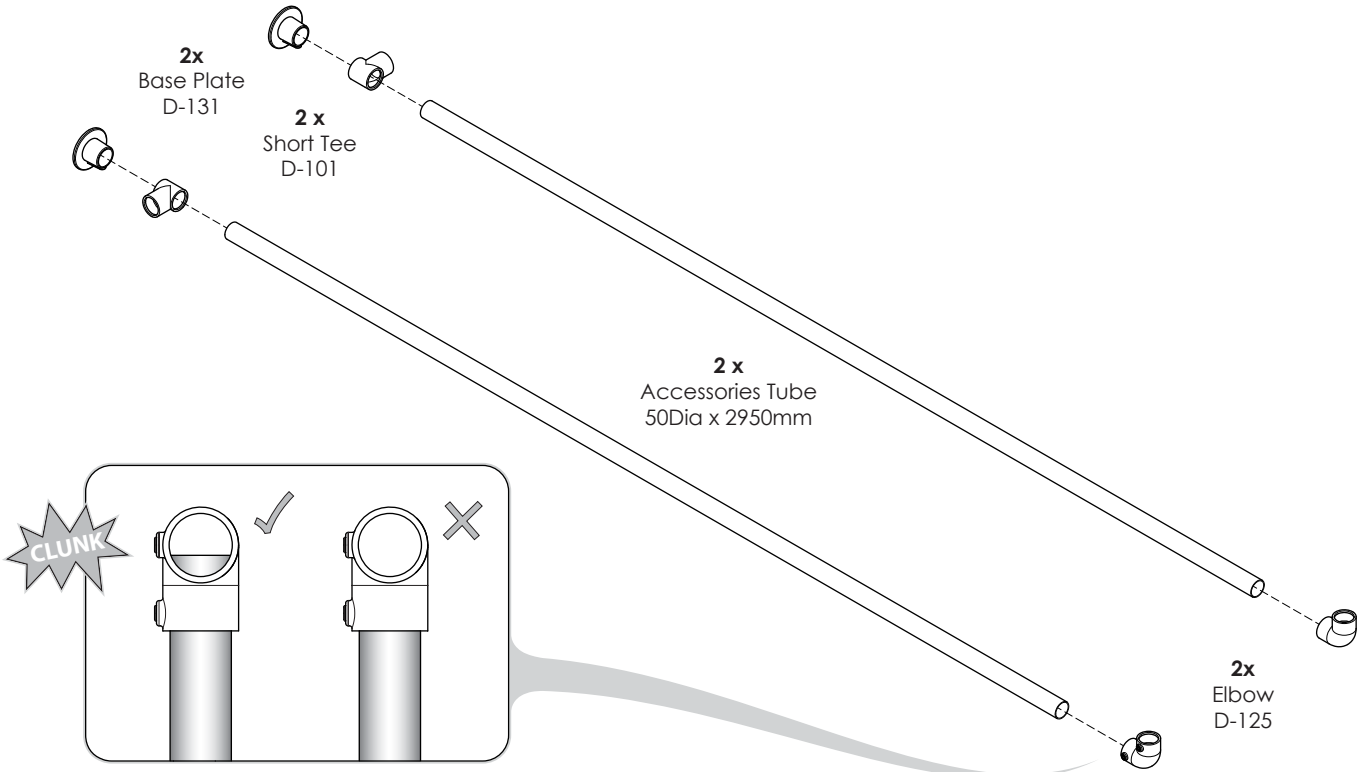

34 ASSEMBLE TOP ACCESSORY TUBE

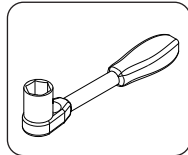
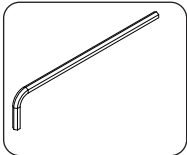

Slide on 4x swing hooks 900mm apart from each other and 100mm away from the ends.

NOTE:

If you have purchased different components for your accessories tube then space out accordingly along the tube
Tighten all grub screws & bolts.

Maximum load on accessories tube is 210 kg or 3 users.

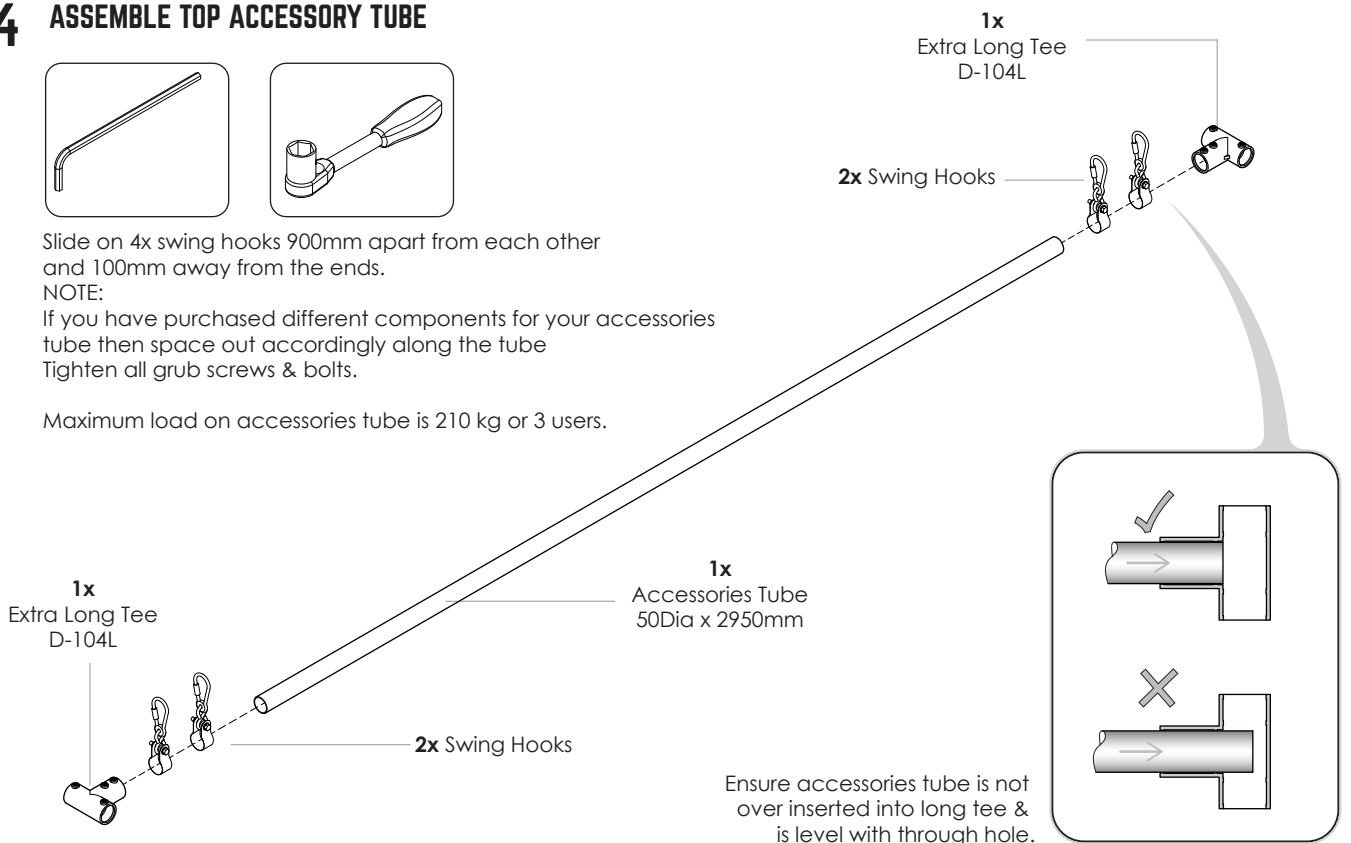

Ensure accessories tube is not over inserted into long tee & is level with through hole.

35 ASSEMBLE TOP ACCESSORY FRAME

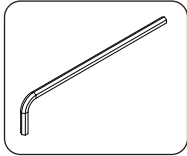

1. Centre 2x cargo tubes on accessory bar.
2. Fully tighten all grub screws.

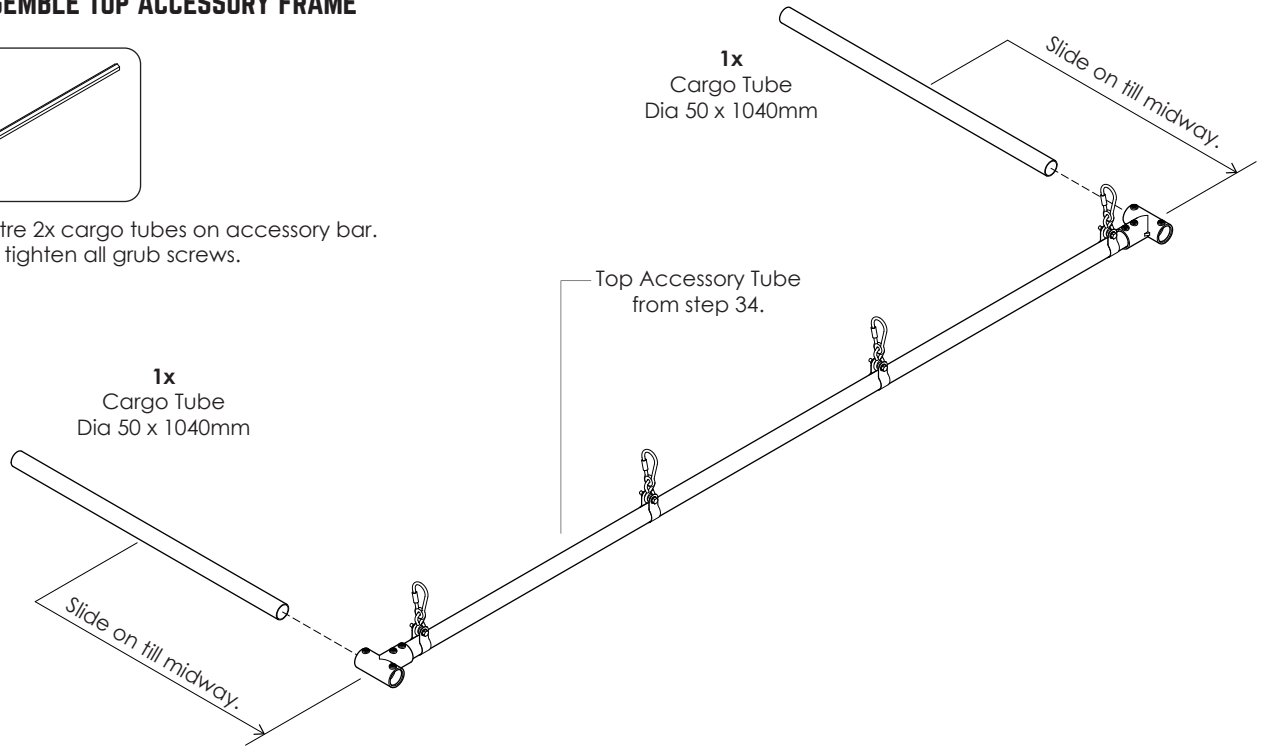

36 ASSEMBLE 3M HEIGHT EXTENDER FRAME

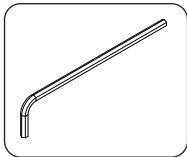

1. Fully engage top accessory frame from step 35 into 3m leg elbows from step 33.
2. Ensure all grub screws will be facing down and outwards when lifted into position. Fully tighten all grub screws.

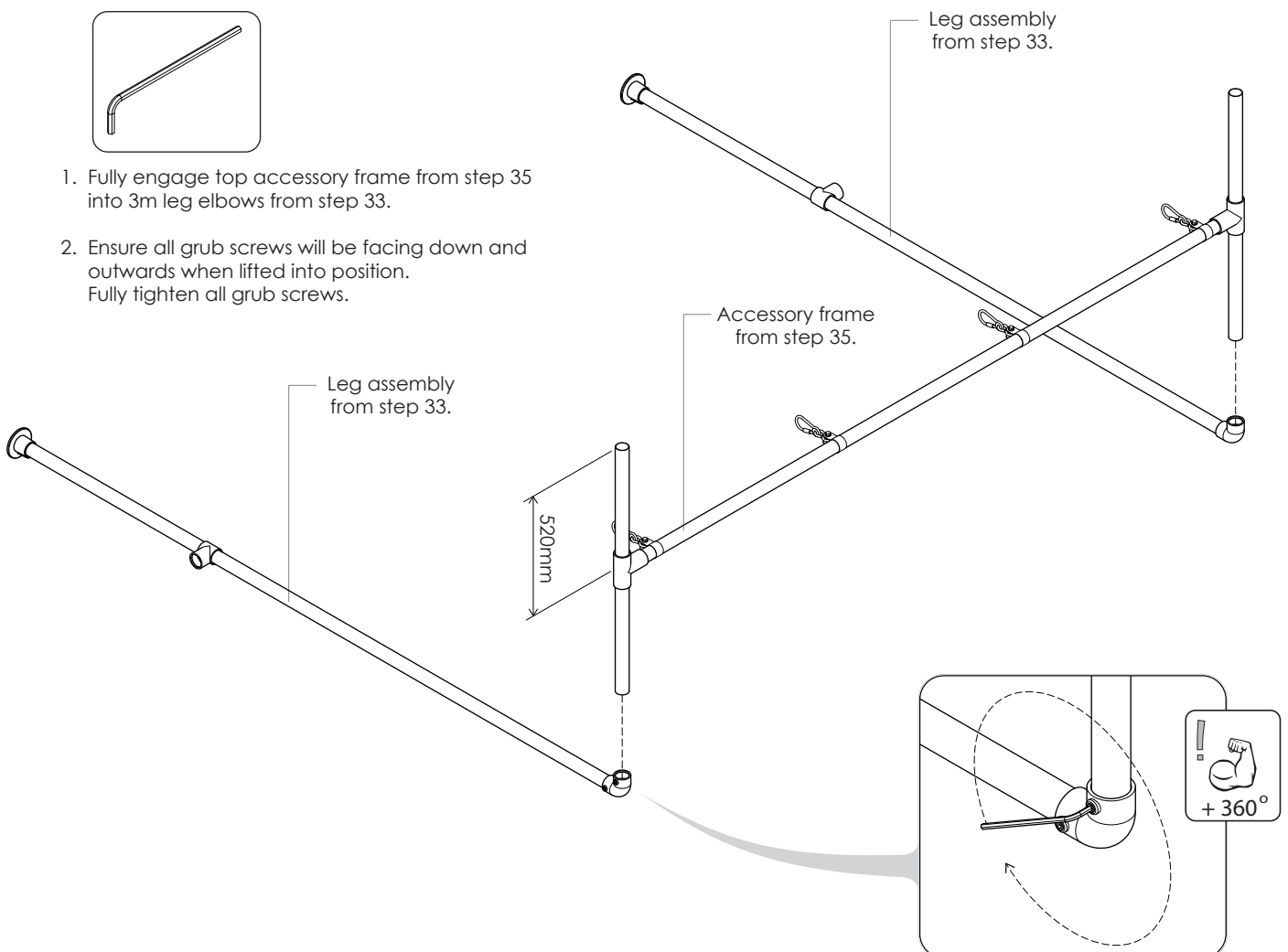

37 RAISE AND CONNECT 3M HEIGHT EXTENDER FRAME

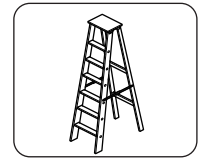
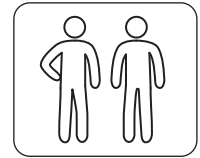
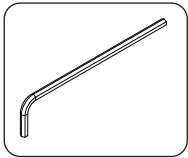

1. With 2 people lift assembled 3m frame into position.
2. Fully slot cargo tubes into top elbows.
3. Fully tighten all grub screws.

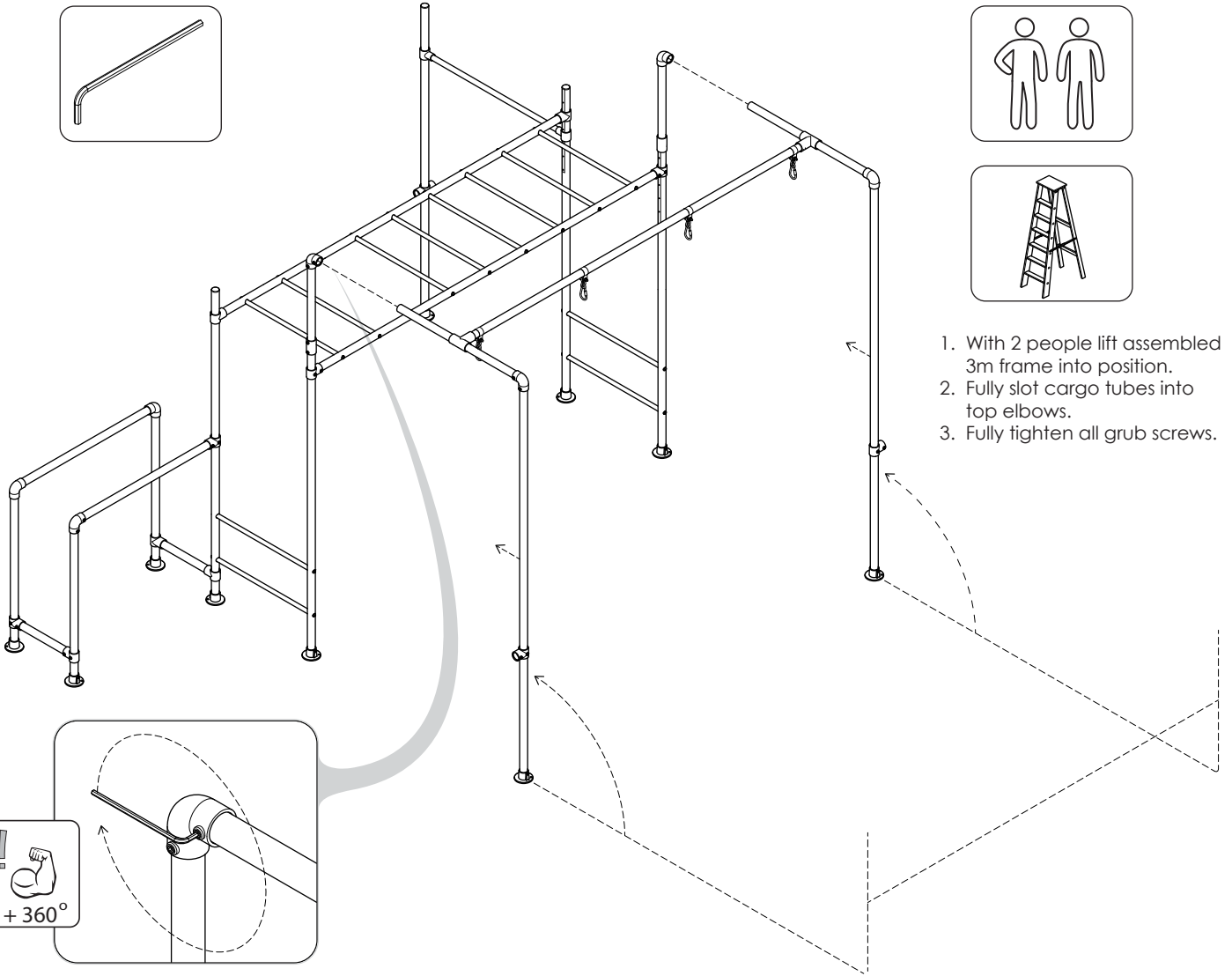

38 SECURE TO GROUND

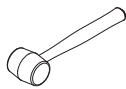
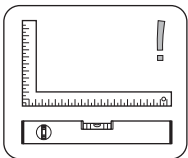

1. Check level and square.
2. Hammer in pegs x2.

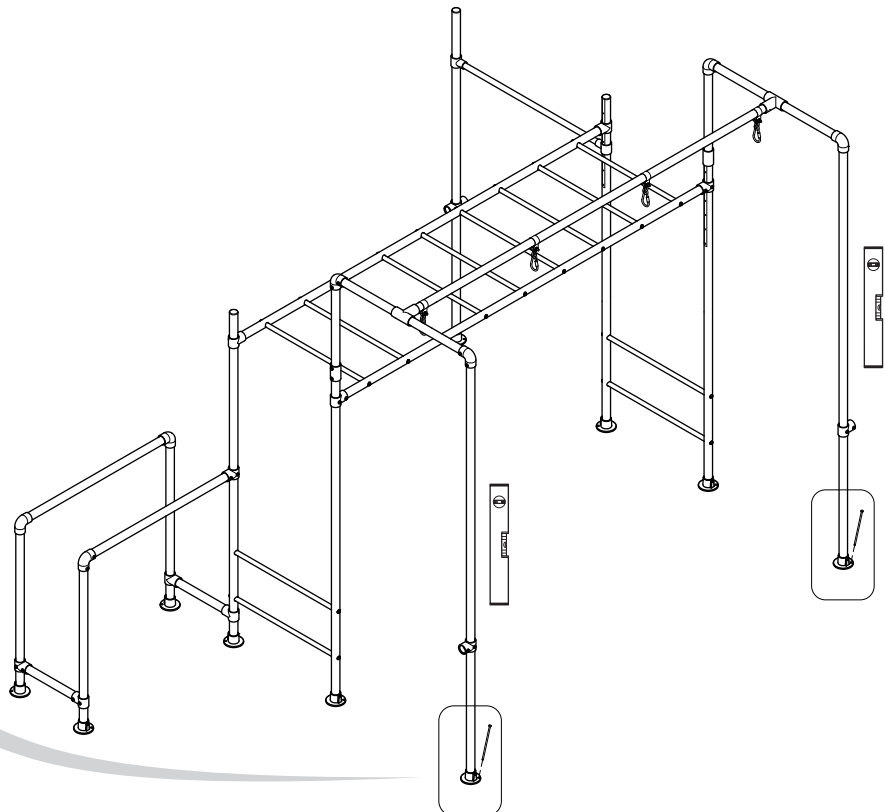
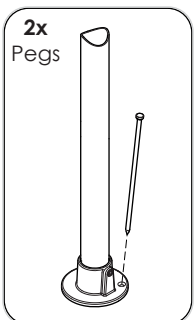

39 ATTACH TWIRLY WHIRLY BARS X4

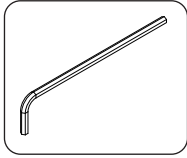

1. Adjust short tees to align level with twirly whirly bars
2. Tighten all grub screws fixing twirly whirlys to legs.

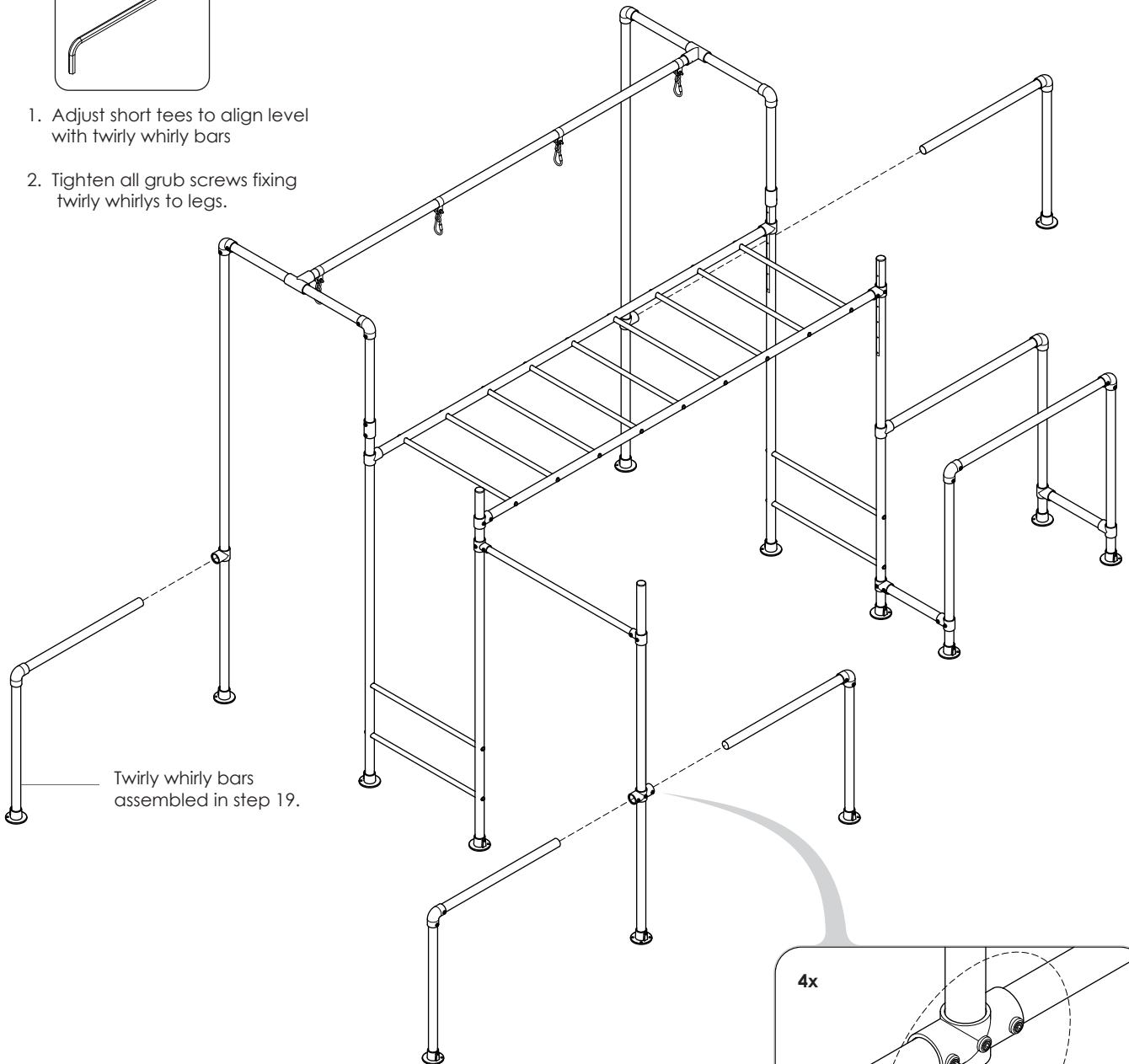

Twirly whirly bars assembled in step 19.

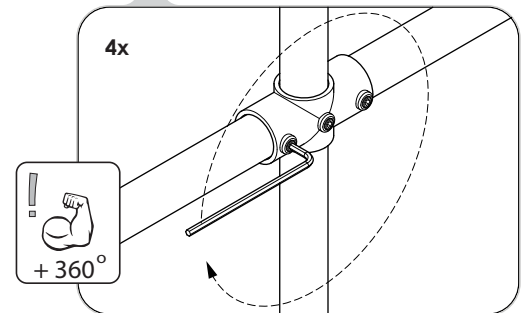

Tighten all grub screws.

40 CHECK ALL FITTING GRUB SCREWS ARE FULLY TIGHTENED

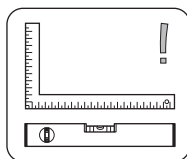
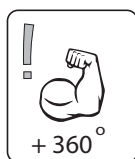
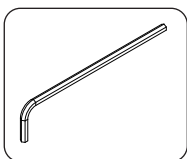

1. Ensure frame is square and level.
2. Firmly tighten all grub screws and bolts.

38 LOAD YOUR TWIRLY WHIRLY BARS X4

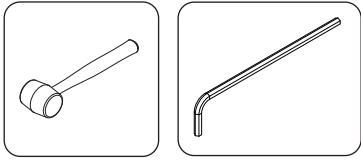

To reduce movement in your frame load your twirly whirly bars as follows.

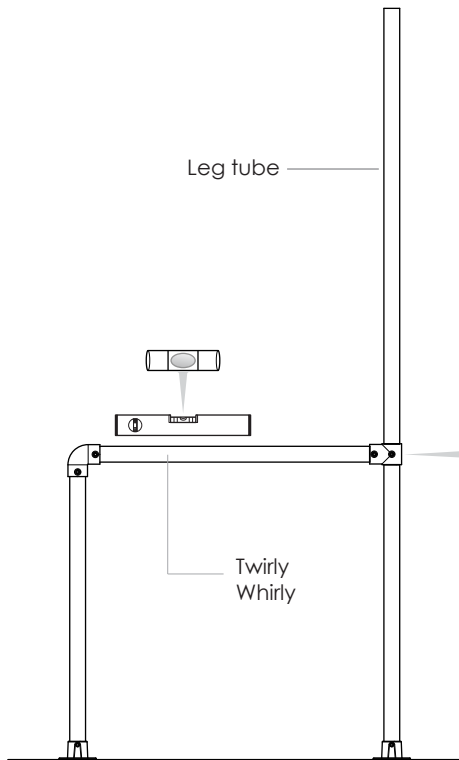

1. Ensure twirly whirly is level and square & leg tube is pegged down.

2. Loosen the grub screw fixing the short tee to the leg tube.

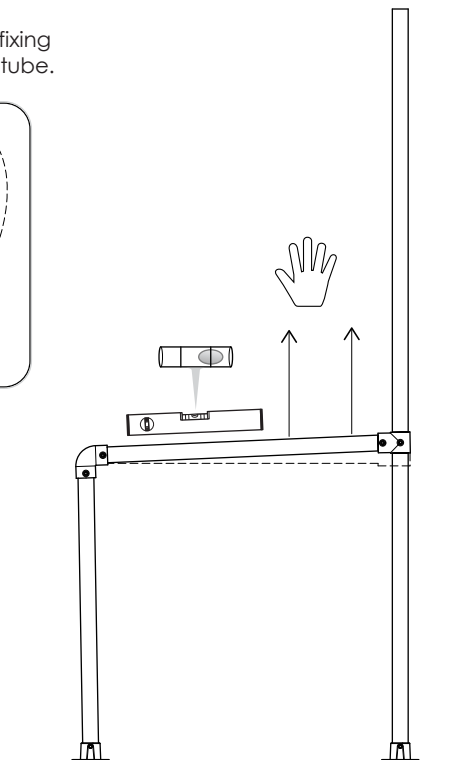
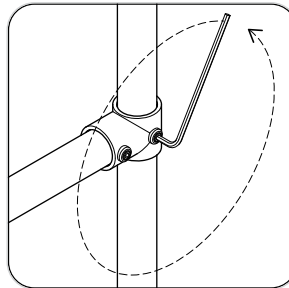

3. Pull upwards on the twirly whirly bar to make a slight angle. (Half a bubble off center on the level)

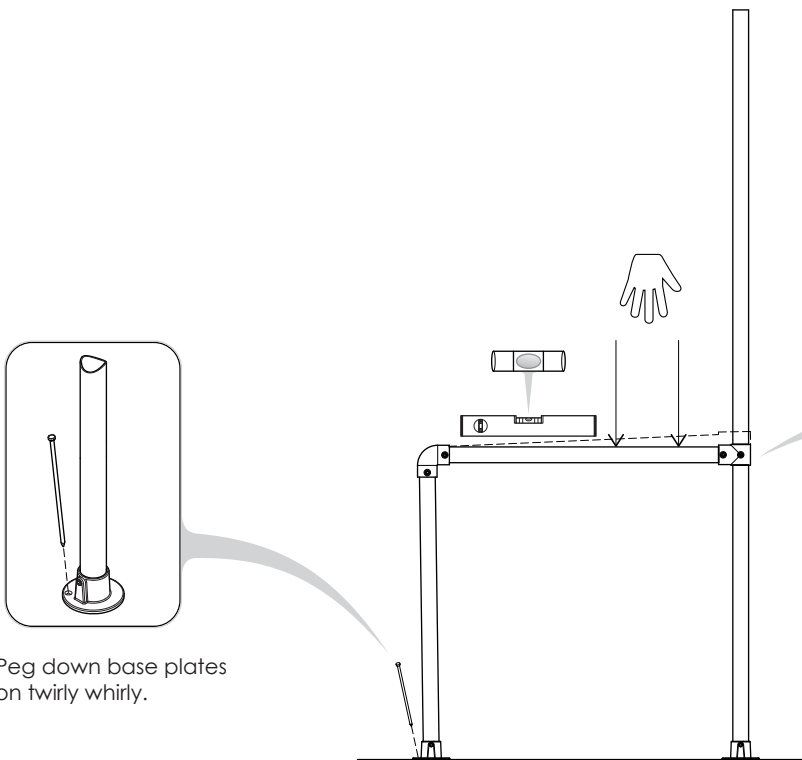

4. Peg down base plates on twirly whirly.

5. Push down on the twirly whirly bar until horizontal bar is level.

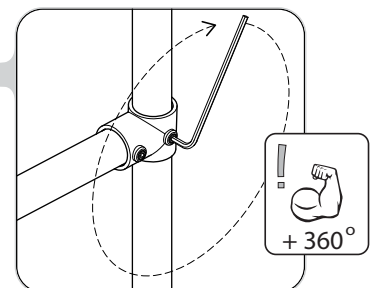

6. Tighten grub screw fixing the short tee to the leg tube. Apply to all twirly whirlys.

REFER TO VIDEO SECTION OF WEBSITE [HTTP://WWW.FUNKYMONKEYBARS.COM/PAGES/VIDEOS](http://www.funkymonkeybars.com/pages/videos)

39 ATTACH ACCESSORIES (IF APPLICABLE)

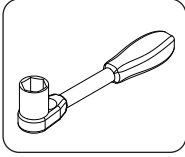

Attach new accessories in desired position (if applicable) and tighten swing hook bolts with ratchet.

Aerial tamarin supplied accessory: (aerial hoop shown)

Aerial Tamarin supplied accessory: (yoga swing shown)

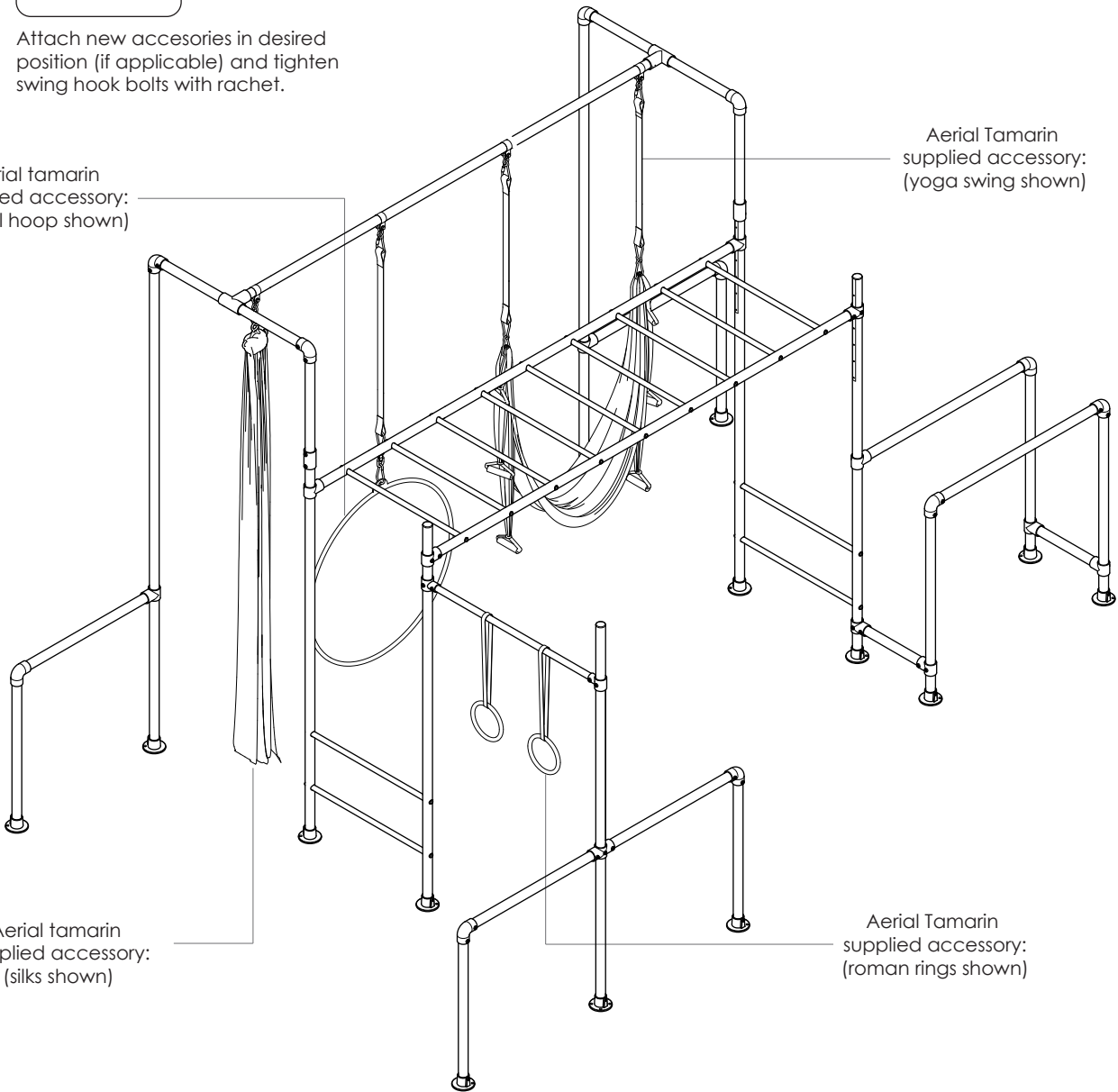

Aerial tamarin supplied accessory: (silks shown)

Aerial Tamarin supplied accessory: (roman rings shown)

40 FINAL CHECKS

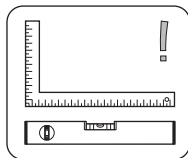
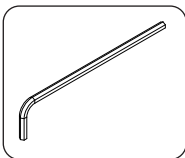

1. Ensure frame is square and level.
2. Firmly tighten all grub screws and bolts.
3. All base plates are pegged down.



Apply your manufacturing sticker to a leg tube.

41 MAINTENANCE.

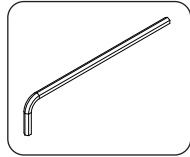
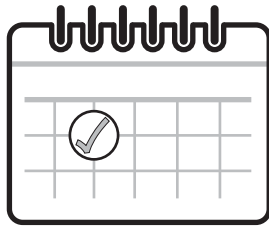

At the beginning of each heavy play session (especially a party) and twice a month during play season ensure;

1. Tighten all hardware - grub screws, nuts and bolts.
2. Pegs are in place and fully secure.
3. Lubricate all metallic moving parts with WD40 or Vaseline - (trolley and swing hooks.)
4. Ensure your frame is level and square.

FAILURE TO DO SO COULD RESULT IN SERIOUS INJURY OR DEATH.

**FOR MORE INFORMATION AND ASSEMBLY TIPS
PLEASE REFER TO OUR WEBSITE VIDEO INSTRUCTION SECTION AT
[HTTP://WWW.FUNKYMONKEYBARS.COM/PAGES/VIDEOS](http://www.funkymonkeybars.com/pages/videos)**

42 HAVE FUN





ABN 72 164 496 520



1300 912 198



info@funkymonkeybars.com



www.funkymonkeybars.com



9 Cutting Way,
Yangebup WA 6164



WE ARE SOCIAL MONKEYS



Australian Government
IP Australia

All Funky Monkey Bars® designs are registered and protected under IP Australia certification.