

FUNKY Monkey bars[®]

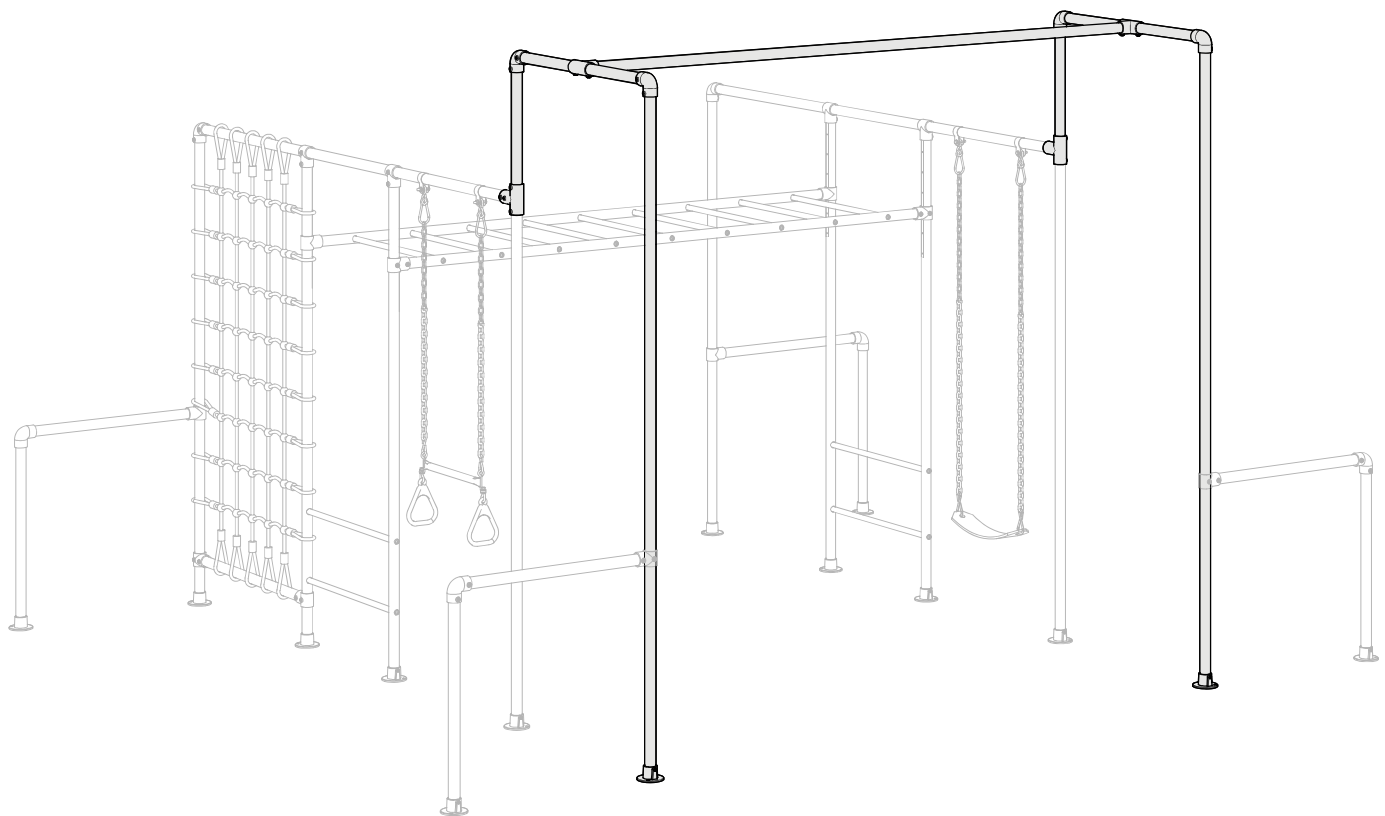

THE HEIGHT EXTENDER (SIDE/A) ADD-ON ASSEMBLY INSTRUCTIONS

CONTENTS

Warnings	Page 1
Load Rating	Page 3
Dimensions	Page 4
Assembly Tips	Page 5
Inventory	Page 7
Assembly Instructions	Page 8
Pre-Installation.	Page 8
Height Extender Installation	Page 11
Maintenance	Page 17

WARNING

PLEASE CAREFULLY READ ALL INFORMATION CONTAINED IN THIS ASSEMBLY MANUAL BEFORE YOU INSTALL AND USE YOUR FUNKY MONKEY BARS®.

SAFETY NOTICE

1. Any person handling or using the Funky Monkey Bars® products must follow the instructions as described in this document. The person in charge of assembling and using the equipment must ensure that the recommendations for use given in this document are seen by all users.
2. Only use the Funky Monkey Bars® after they have been fully assembled and after checking that the fittings are tightened properly (*refer to page 5 - Correct Tightening Method*).
3. DO NOT install your Funky Monkey Bars® over concrete, asphalt, packed earth, wood decking or any other hard surface. A fall onto a hard surface can result in serious injury or death.
4. Inspect all grub screws, bolts and nuts at the beginning of each play session to ensure your Funky Monkey Bars® are tight and secure.
5. Ensure all tubes are fully inserted into fittings until you hear the magic "CLUNK" sound.
6. Ensure your Funky Monkey Bars® are properly secure at ALL times. Pegs are in place and inserted fully into the ground.
7. DO NOT exceed the maximum load/weight limit as recommended by Funky Monkey Bars®.
8. Children should be supervised by an adult at all times.
9. Installing a gym/crash mat under the fall zone area of your Funky Monkey Bars® would be recommended for children learning this new skill. This will reduce the chance of injury and build the child's confidence while they build strength and master the skill.
10. Ensure you have thoroughly read your assembly and installation instructions and viewed our on-line installation videos at <https://www.funkymonkeybars.com/blogs/installation-maintenance-videos>
11. DO NOT climb, sit or stand on top of the monkey bar (horizontal ladder) section.
12. DO NOT jump from the top of any section of the monkey bar.
13. DO NOT use your Funky Monkey Bars® when wet as the steel will be slippery.
14. DO NOT attach items to your frame that are not designed specifically to be used with Funky Monkey Bars®, especially lower quality products that have not been approved by Funky Monkey Bars®.
15. Ensure the height of your Funky Monkey Bars® (horizontal ladder) are set at a level that is age appropriate.
16. DO NOT install your Funky Monkey Bars® over or near objects that could interfere with users in an unsafe way. Maintain a clear area around your Funky Monkey Bars®.
17. DO NOT use your Funky Monkey Bars® while under the influence of drugs and alcohol.
18. Wear clothing free of drawstrings, hooks, loops or anything that could get caught while using your Funky Monkey Bars® and result in entanglement and/or strangulation.

ASSEMBLY

1. Keep small children away from the Funky Monkey Bars® during assembly.
2. Do not attempt to use the Funky Monkey Bars® until it is completely assembled and every fitting is tight and secured.
3. Installation typically takes 1-2 hours to complete. Two people are recommended for assembly.
4. Ensure all fittings are tightened to the correct tightening method as described on page 5.
5. Assembly should be carried out on clean, dry, level surface

Please refer to the video section on the Funky Monkey Bars® website for more handy tips and assembly instructions at <http://www.funkymonkeybars.com/pages/videos>

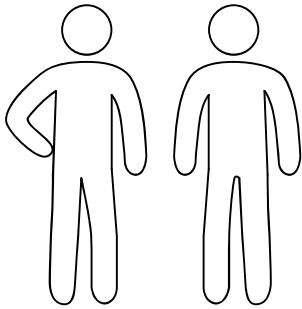

Assembly requires 2 adults.

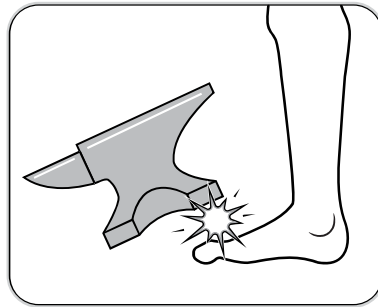

Heavy items !

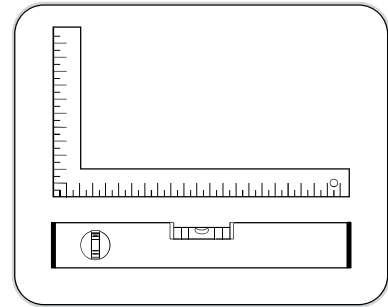

Work on flat level surface.

LOCATION

1. A safe fall zone around your Funky Monkey Bars® is essential. A minimum distance of 1.5m to 2m (5 ft to 6.5ft) is recommended around the elevated hanging points of your Funky Monkey Bars®.
2. Place your Funky Monkey Bars® on level ground, away from any structure or obstruction such as a fence, garage, house, overhanging branches, laundry lines or electrical wires and remove any obstructions beneath your Funky Monkey Bars®.
3. Ensure your Funky Monkey Bars® are positioned away from retaining walls, pool fences, structures and other play equipment. Maintain a clear space around the whole perimeter of your Funky Monkey Bars®.
4. Place your Funky Monkey Bars® on the most level surface available.

MAINTENANCE

1. At the beginning of each heavy play session we recommend the following maintenance processes be performed on your Funky Monkey Bars®:
 - Tighten all bolts, grub screws and applicable hardware (as per page 5)
 - Lubricate all metallic moving parts as per instructions (flying fox, swing hooks etc)
 - Check all protective coverings on bolts, pipes, edges and corners. Replace if they are loose, cracked or missing.
 - Check all moving parts including swing seats, shackles, snap hooks, chains and trolleys for wear, rust, or other deterioration. Replace as needed.
2. Twice a month during play season we would recommend the following maintenance processes be performed on your Funky Monkey Bars®:
 - Tighten all connections and hardware
 - Check all protective coverings on bolts, pipes, edges and corners. Replace if they are loose, cracked or missing.
3. Once a month during play season we would recommend the following maintenance processes be performed on your Funky Monkey Bars®:
 - Lubricate all metallic moving parts as per instructions (flying fox, swing hooks etc). If swings start to squeek then lubricate swing hooks.
 - Check all moving parts including swing seats, ropes, chains and trolleys for wear, rust, or other deterioration. Replace as needed.
 - Owners shall be responsible for maintaining the legibility of any warning labels.

For additional information concerning your Funky Monkey Bars®, please contact our customer service team or check our website for any important updates. Phone - 1300 912 198 or www.funkymonkeybars.com



QUALITY & INDEPENDENT TESTING

At Funky Monkey Bars® we take the quality of our designs and safety very seriously. All Funky Monkey Bars® frames go through a stringent, independent structural testing process prior to being made available for release to our customers.

Our frames are designed within the parameters of the Australian Standard for Playground Equipment AS4685.1:2014.

The structural integrity of our frames has been tested for performance through a combination of engineering calculations and physical testing. The tests have been performed by independent, certified structural engineers in accordance with Australian Standard for Playground Equipment AS4685.1:2014 and European Standards EN1176-1:2008.

The independent testing conducted on The Height Extender (side) certified the frame to a load rating of 1098kgs or 18 users of 61kgs when installed on The Orangutan and 1525kg or 25 users of 61kgs when installed on The Gorilla. The maximum number of users on The Height Extender (side) accessories bar is to be 3 users (180kgs)

LOAD TESTING CERTIFICATION				
DATE OF TEST	MODEL	NUMBER OF USERS	USER LOAD (KG)	LOAD RATING (KG)
3 May 2019	Height Extender (side) on Orangutan	3	60	180
3 May 2019	Height Extender (side) on Gorilla	3	60	180
I hereby confirm all testing was undertaken in accordance with Physical Testing of Structural Integrity requirements of AS 4685.1: 2014 App C / EN 1176-1:2008 ^o except where noted below;				
COMMENTS: Maximum of 3 users on Height Extender accessories bar. (180kgs)				
APPROVED BY: Funky Monkey Bars®		WITNESSED BY: Independent Engineer		
				
DATE : 21 June 2019		DATE : 21 June 2019		

**FUNKY MONKEY BARS®
HEIGHT EXTENDER (SIDE) OVERALL DIMENSIONS**

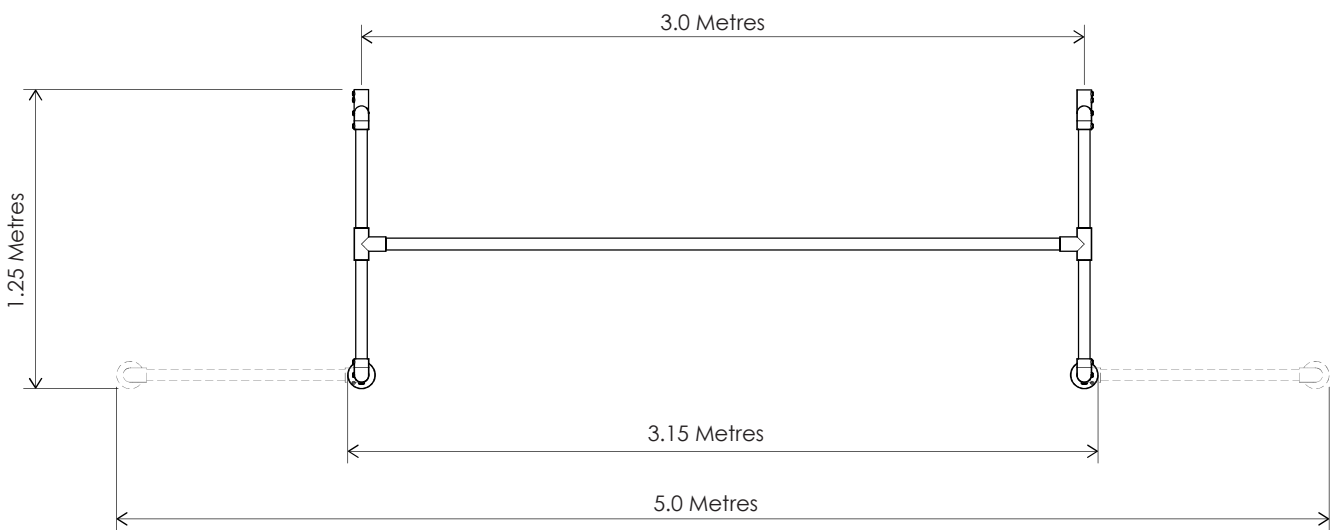
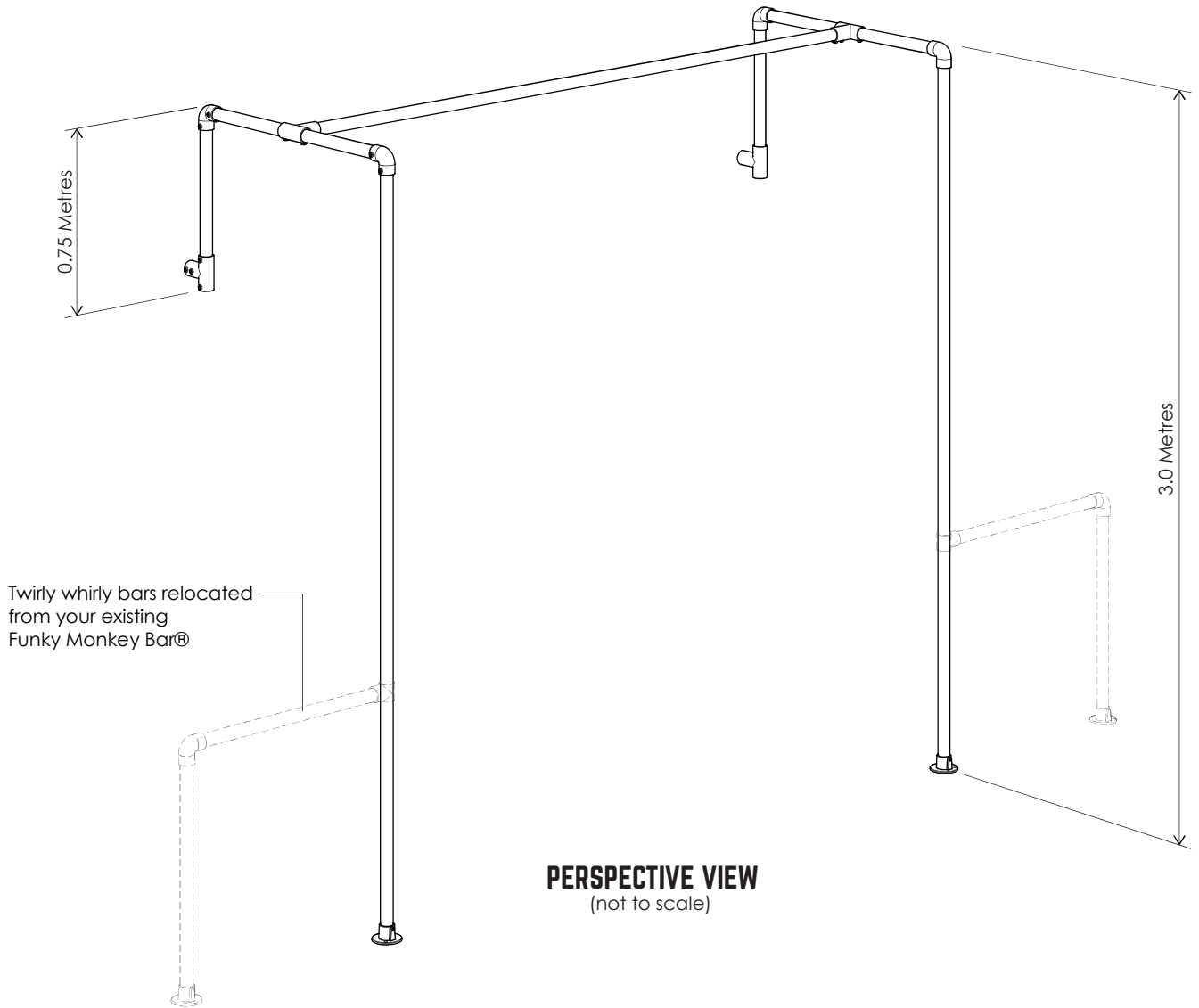

CORRECT INSERTION INTO FITTINGS - (INDICATIVE DIAGRAM SHOWN)

All tubes must be fully inserted until contact is made with adjoining tube.

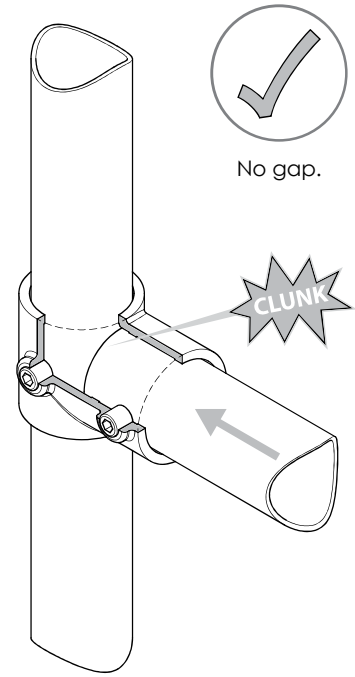
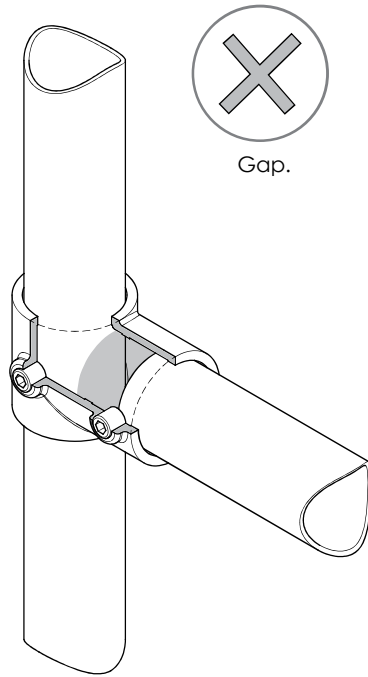

CORRECT TIGHTENING METHOD OF GRUB SCREWS - (INDICATIVE DIAGRAM SHOWN)

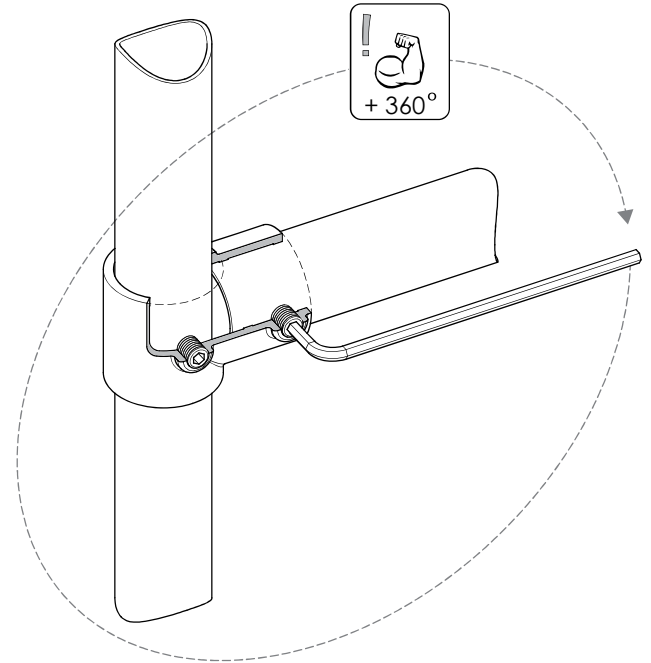
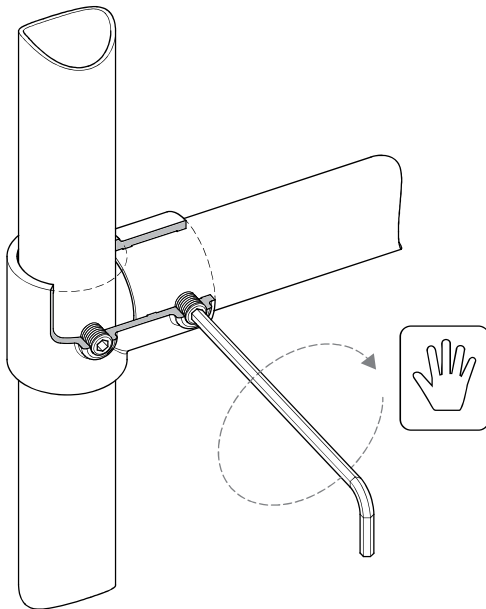

1. With long end of the allen key, hand tighten grub screw as much as possible.



2. Using other end of the allen key do one full 360 degree turn as a minimum, use muscles!



IT IS CRITICAL YOUR MAIN FRAME IS 100% SQUARE AND LEVEL - (INDICATIVE DIAGRAM SHOWN)

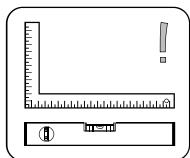

Check assembly is 100% level, square & straight.

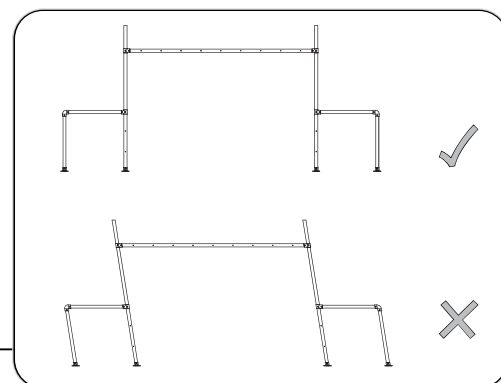
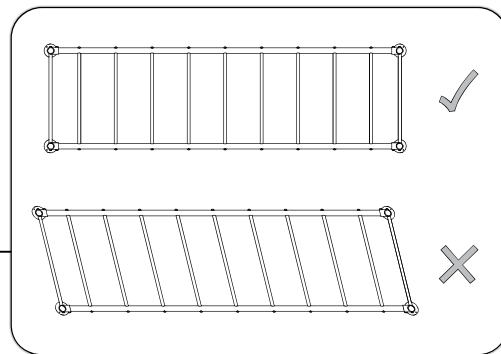
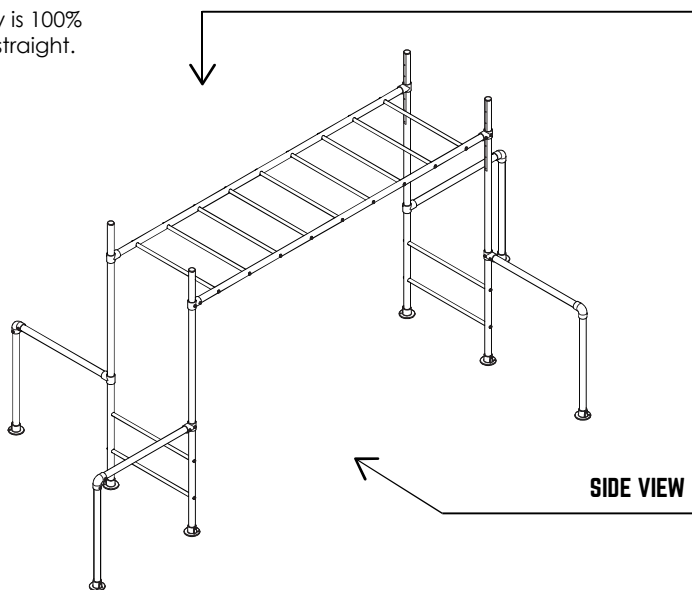

If your frame is not straight or level remove pegs, loosen grub screws, re-adjust re-tighten and re-peg the frame.

INSTALLATION ON A SLOPE

If your frame is being installed on a slope ensure the monkey ladder bar is level. Either install at different heights on the legs or dig down at one end until level.

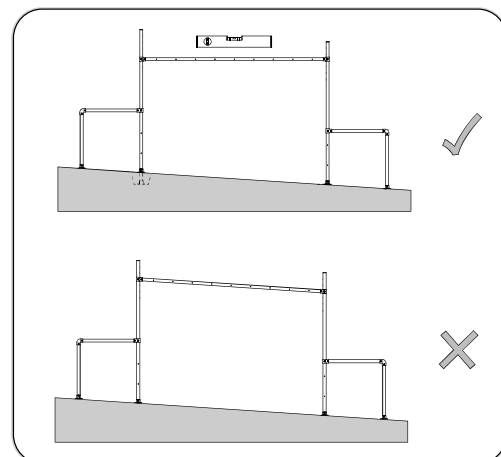

FIXING TYPICAL ORIENTATION - (INDICATIVE DIAGRAM SHOWN)

Unless otherwise stated all grub screws and fittings should face downwards and outwards. This will reduce weathering damage, help with assembly and ease of maintenance.

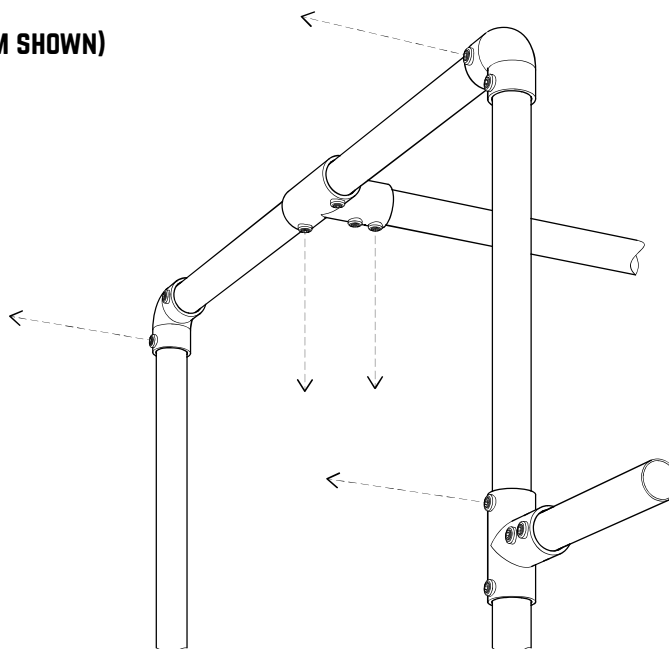

INVENTORY

TOOLS REQUIRED FOR INSTALLATION

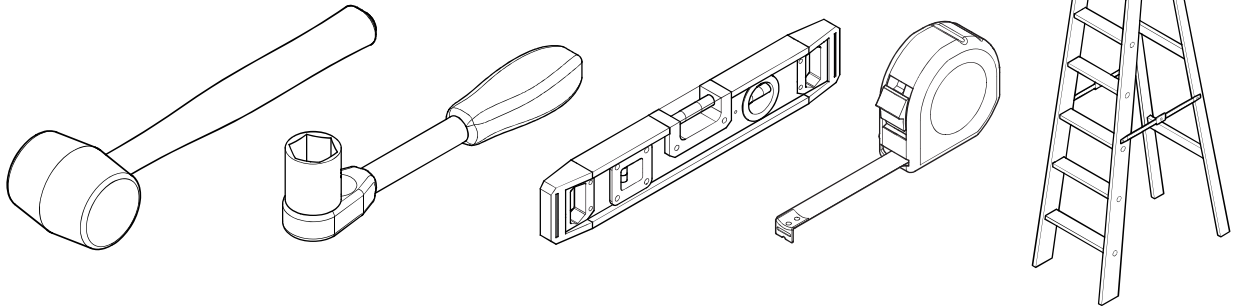

1x
8mm Allen key
(Included)

1x
Soft Hammer
(Not included)

1x
17mm Ratchet
(Not included)

1x
Spirit Level
(Not included)

1x
Tape Measure
(Not included)

1x
3m Step Ladder
(Not included)

TUBES

2x
Extender
Tube

50Dia. x 600mm

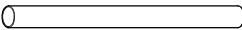

2x
Cargo Tube

50Dia. x 1040mm



3x
Accessories Tube

50Dia. x 2950mm



FITTINGS

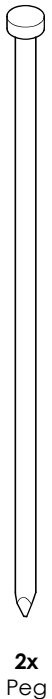
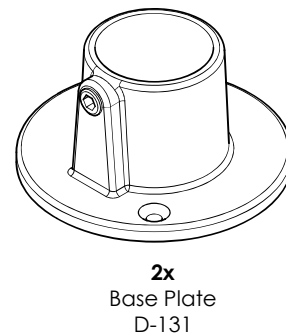
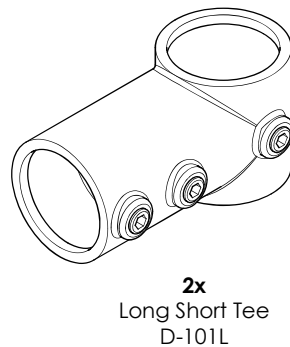
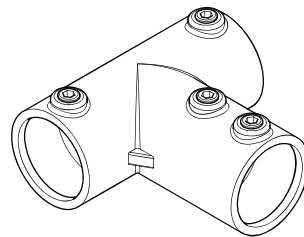
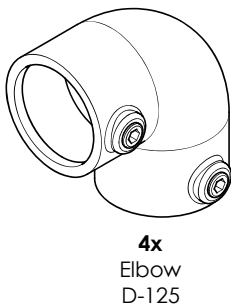

One of the best things about a Funky Monkey Bar is the ability to add new equipment and accessories as your child and family grows. You can swap or add accessories to your existing frame, or add extra frames that will give you more versatility to attach equipment. Check out what we've got in store now at...

WWW.FUNKYMONKEYBARS.COM

1 SELECT THE LOCATION FOR THE HEIGHT EXTENDER (SIDE) - (GORILLA MODEL SHOWN)

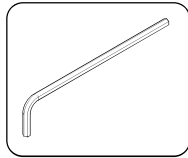

- Depending on your Funky Monkey Bars® model and configuration select a side for the Height Extender to be installed. Funky Monkey Bars® recommends the opposite side to the cargo net, for ease of assembly and safety.

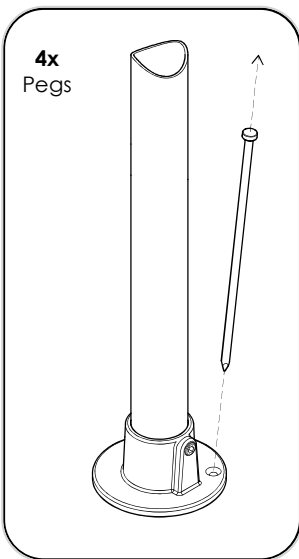
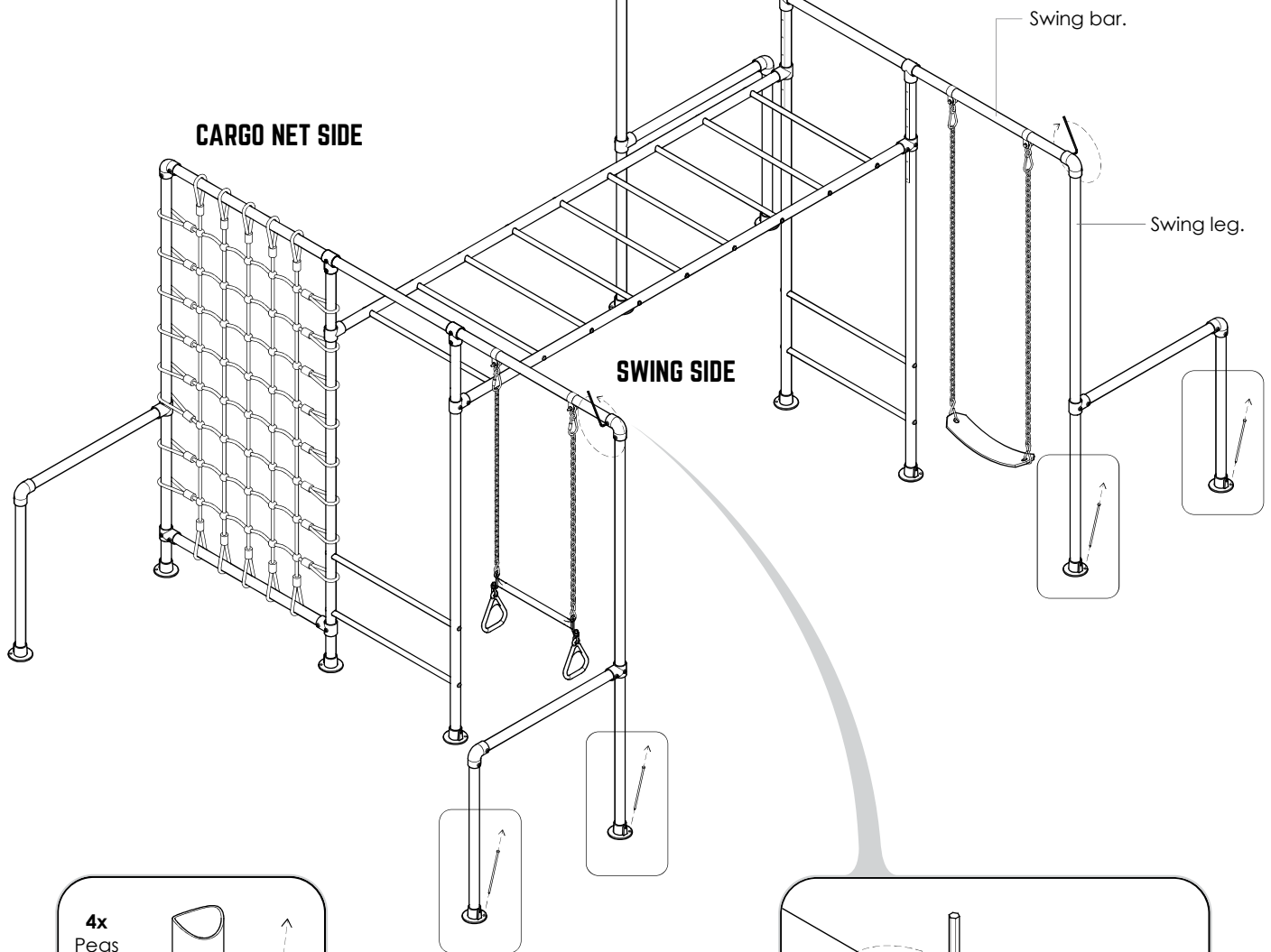

- Remove base plate pegs from swing legs and twirly whirly bars on selected side.

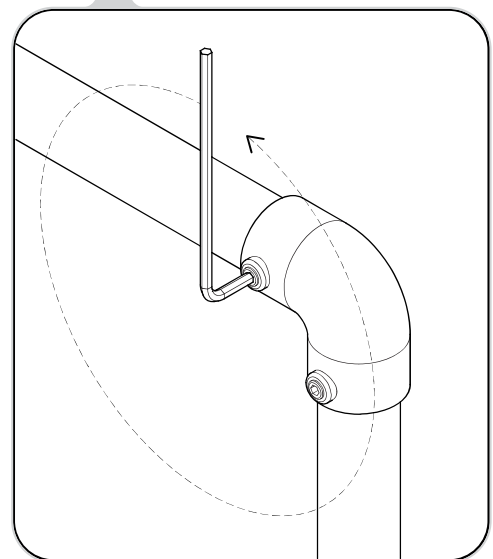

- Loosen grub screws connecting the swing legs to the swing bars on both ends of the selected side.

2 LOWER LEGS AND REMOVE SHORT TEES, TWIRLY WHIRLYS & ELBOWS

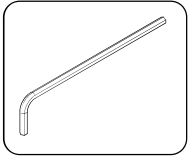

1. Remove any accessories if applicable.
2. Lower legs and remove twirly whirly bars.

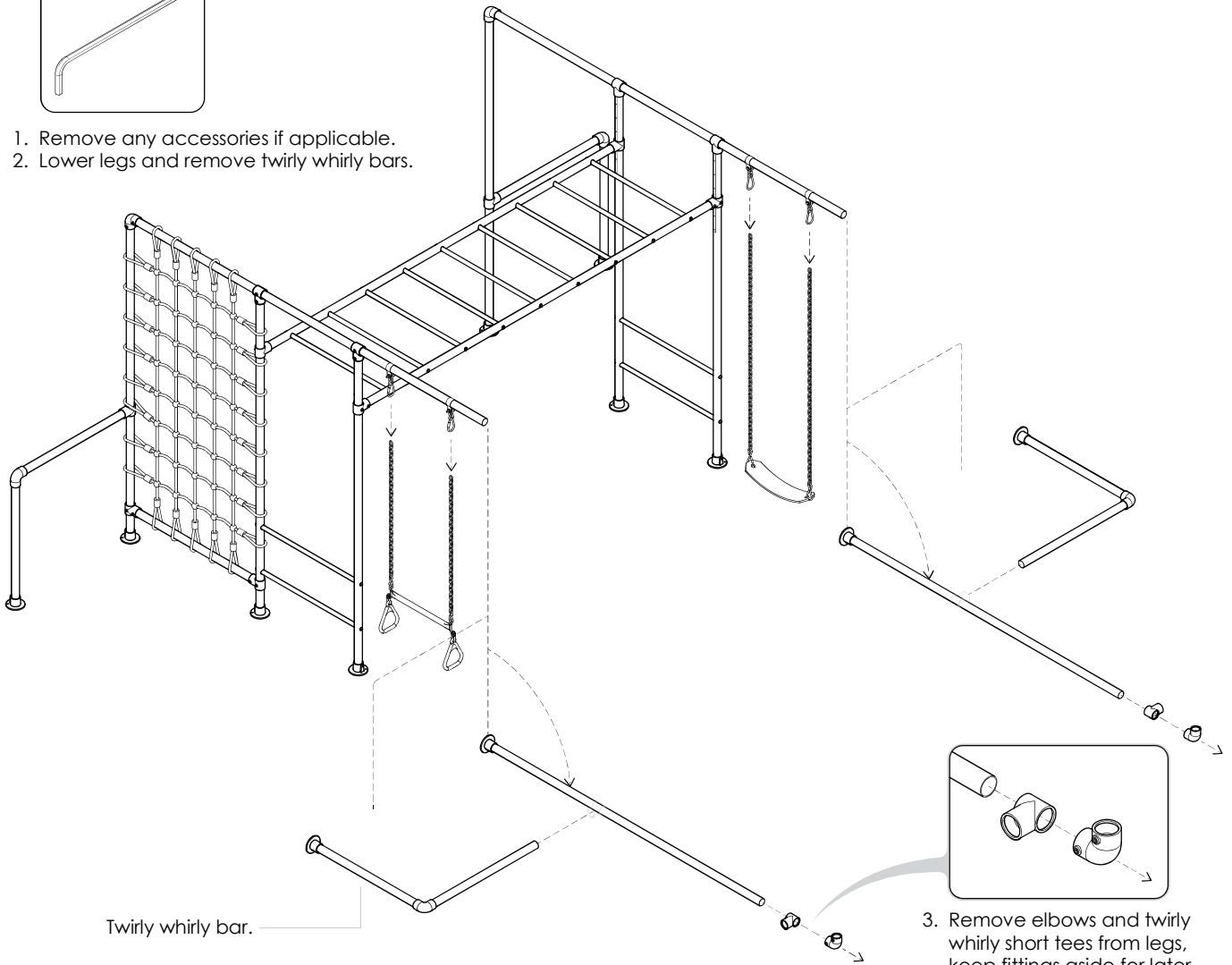

3 ASSEMBLE LEGS X2

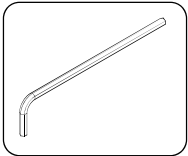

Slide extra long tees onto lowered legs from step 2, and tighten grub screws.

Ensure leg is not over inserted - & is level with side hole.

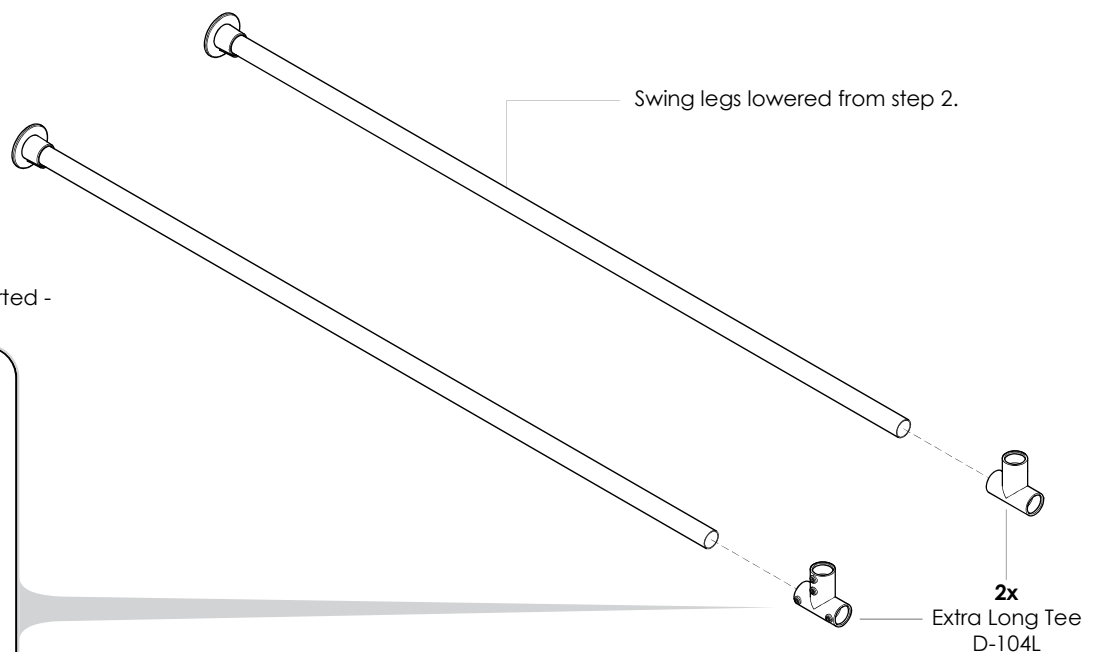
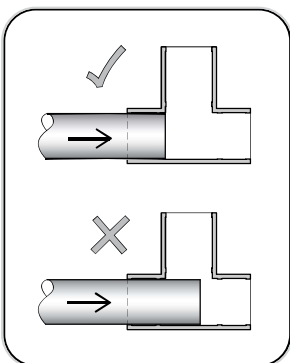

4 RE-ATTACH SWING LEGS

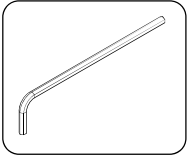

Firmly tighten all grub screws.

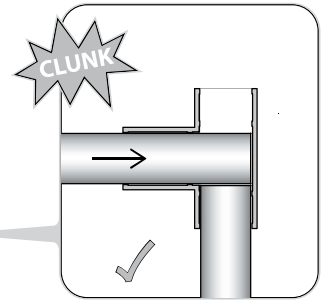

Ensure swing bar is fully inserted into swing leg extra long tee.

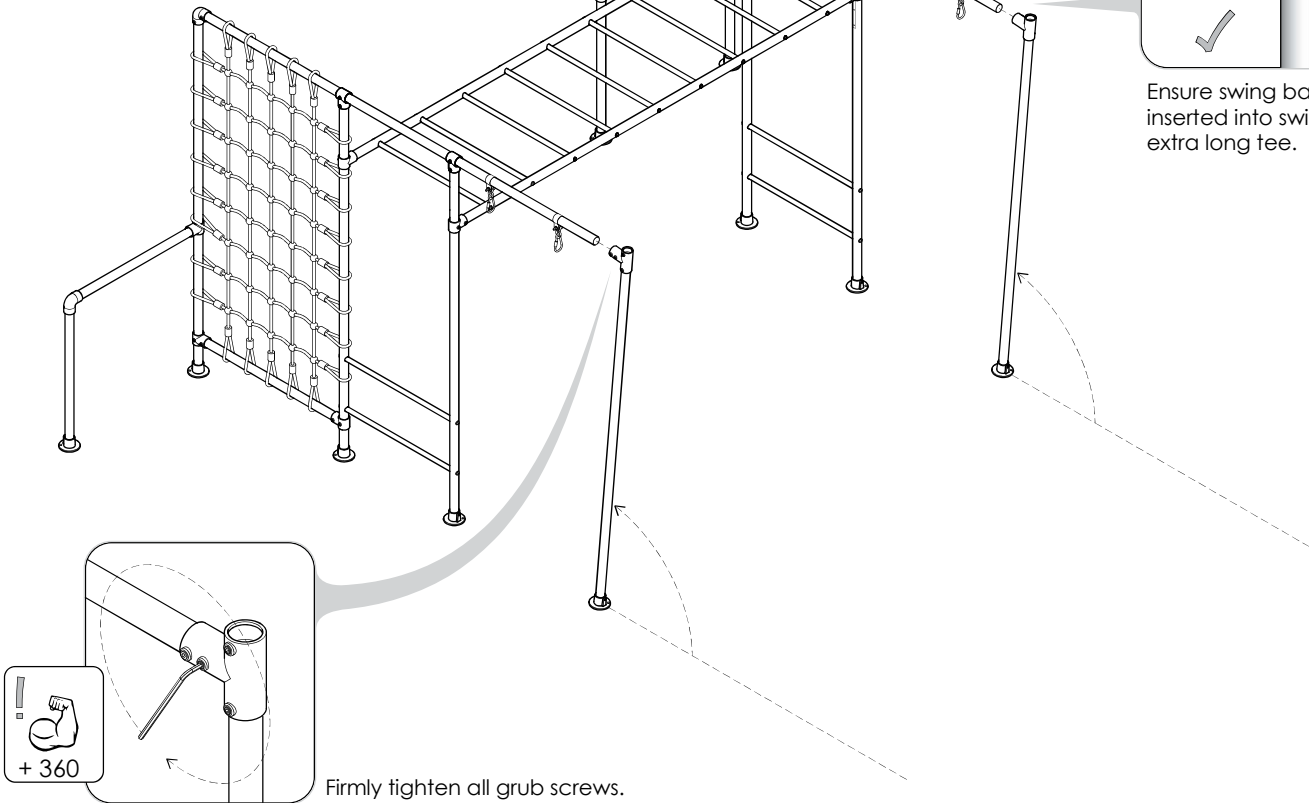

Firmly tighten all grub screws.

5 SECURE TO GROUND

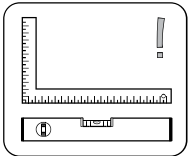

1. Check level and square.
2. Hammer in pegs x2.

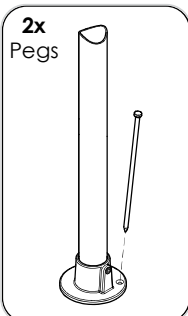

2x Pegs

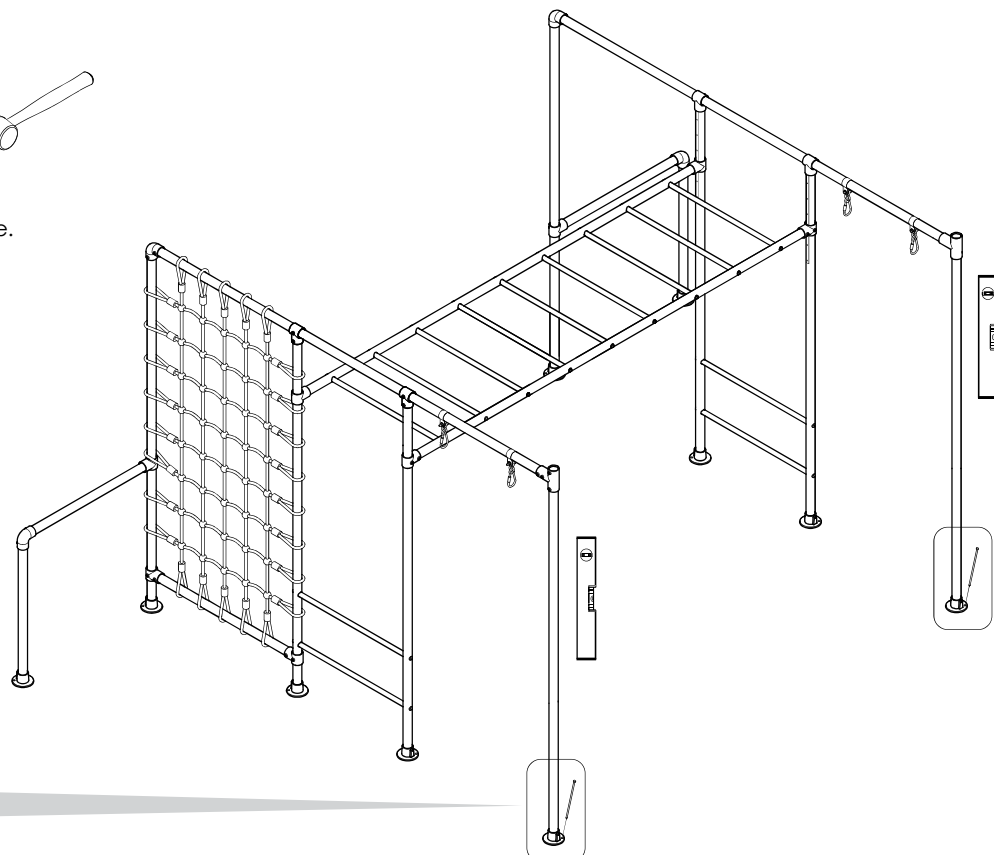

6 INSERT EXTENDER TUBES X2

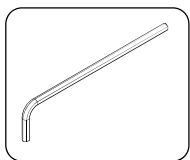

Insert extender tubes into extra long tee open end and leave hand tight whilst installing extender frame.

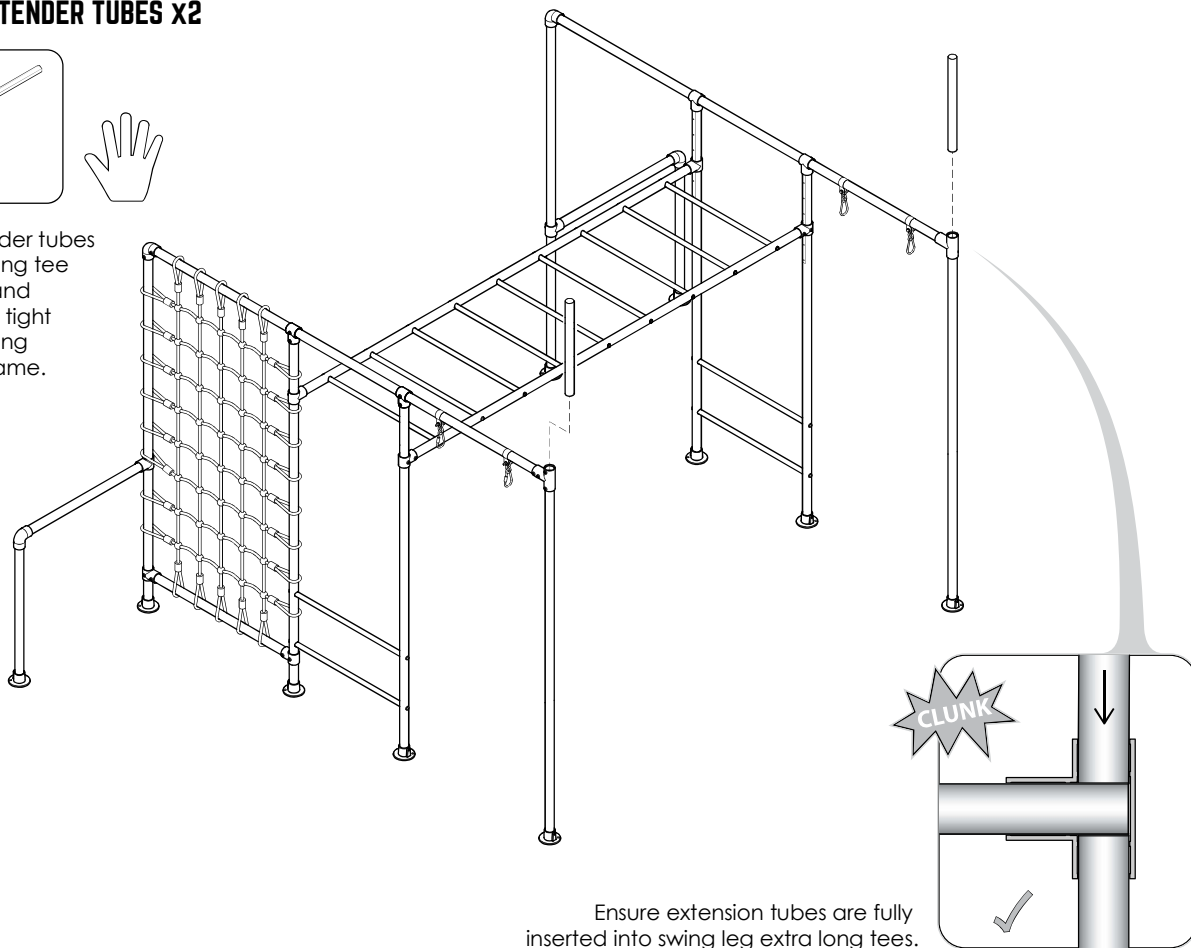

Ensure extension tubes are fully inserted into swing leg extra long tees.

7 ASSEMBLE 3M LEGS

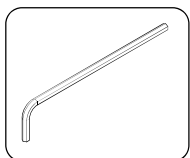

Slide onto accessories tube - short tees and base plates. Leave grub screws on short tees loose. Firmly tighten all other grub screws.

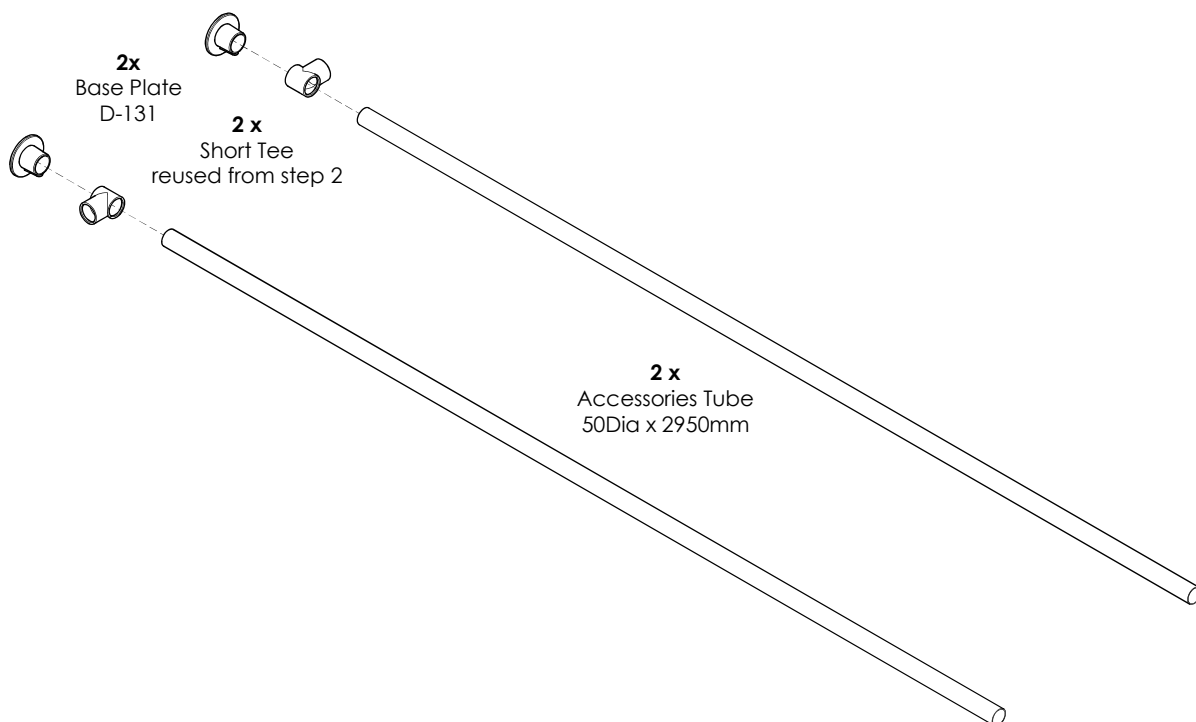

8 ASSEMBLE TOP ACCESSORY TUBE

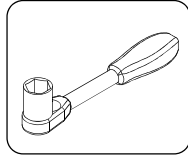
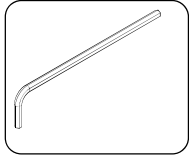

NOTE:
If you have purchased components for your accessories tube then equally space out swing hooks along the tube, Tighten all grub screws & bolts if applicable.

Maximum load on accessories Tube is 210 kg or 3 users.

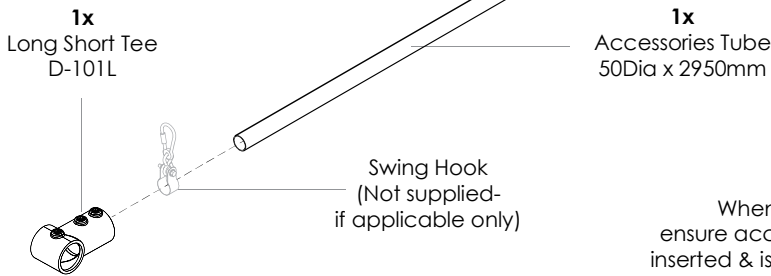

When inserting extra long tee ensure accessories tube is not over inserted & is level with through hole. Once correctly inserted tighten grub screws.

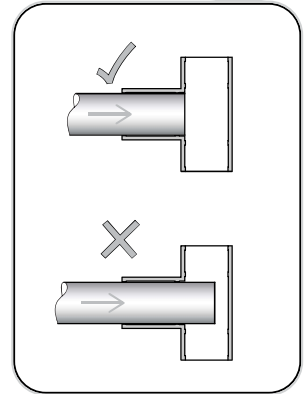

9 ASSEMBLE TOP ACCESSORY FRAME ON GROUND

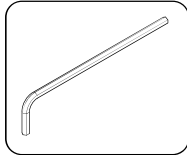

1. Centre accessory bar on cargo tubes.

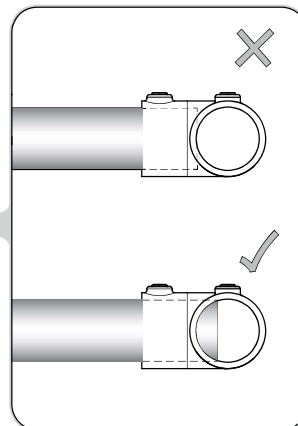
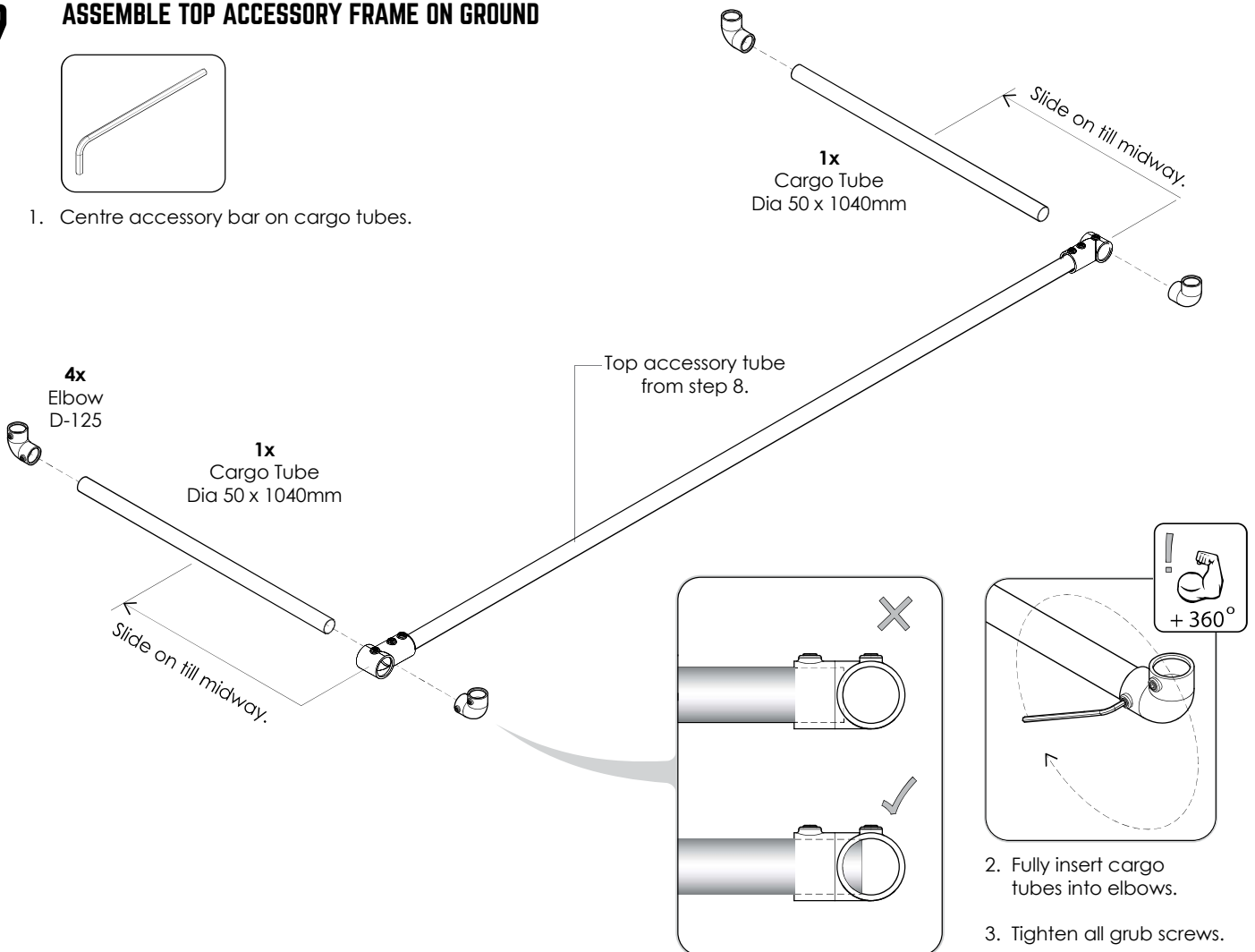

10 ASSEMBLE 3M HEIGHT EXTENDER FRAME

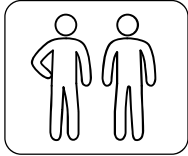
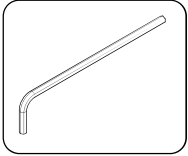

1. Fully engage top accessory frame from step 9 into 3m leg elbows from step 7.
2. Fully tighten all grub screws.

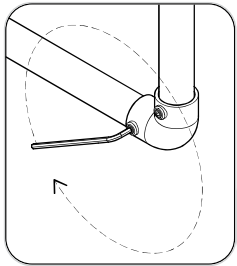
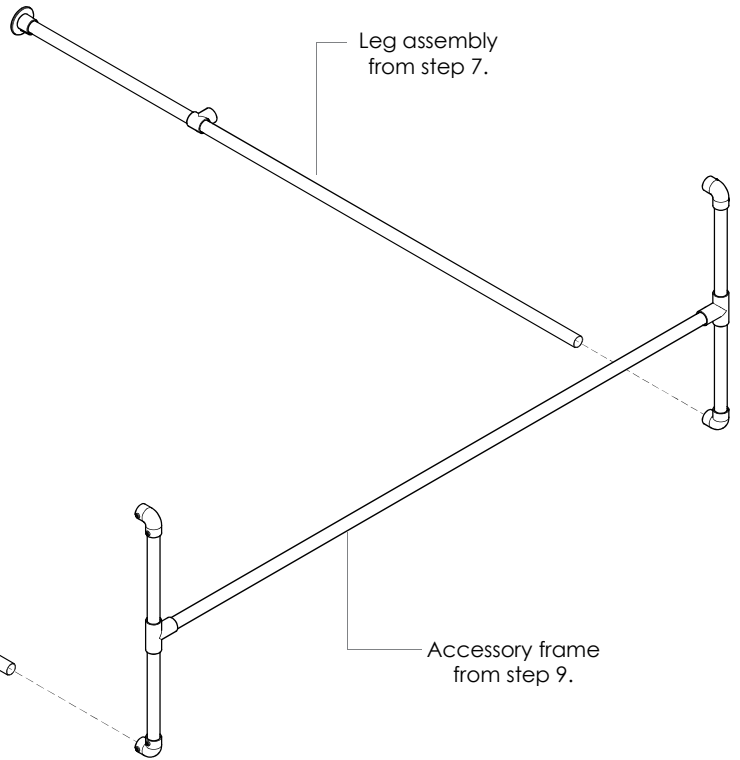

11 RAISE AND CONNECT 3M HEIGHT EXTENDER FRAME

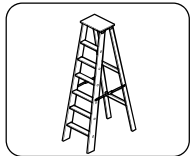
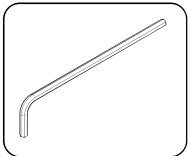

1. With 2 people lift assembled 3m frame into position.
2. Slot elbows onto extension tubes, fully tighten all grub screws.

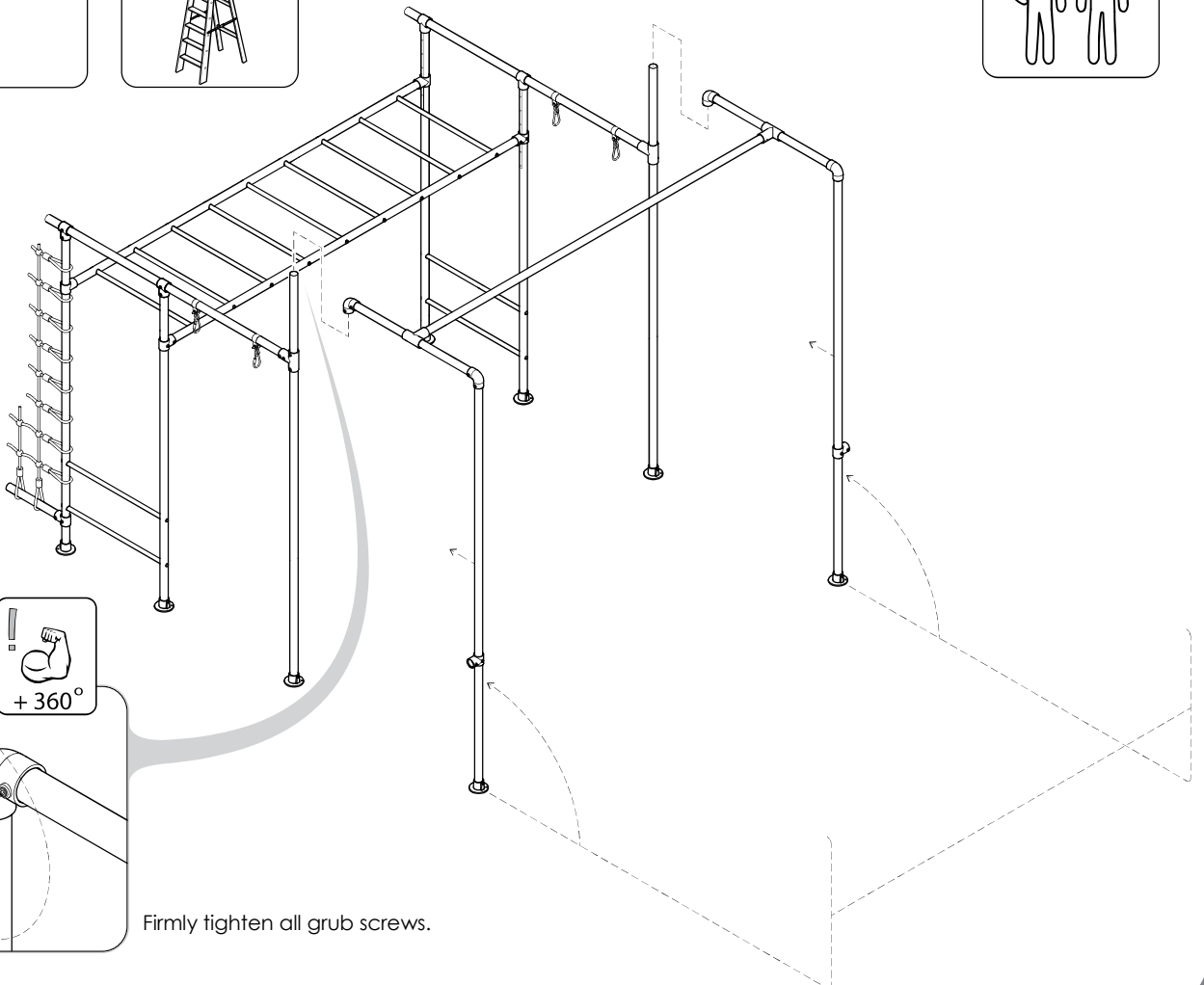
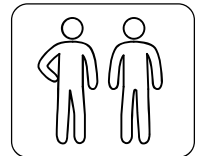

12 SECURE TO GROUND

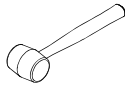
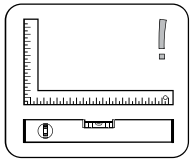

1. Check level and square.
2. Hammer in pegs x2.

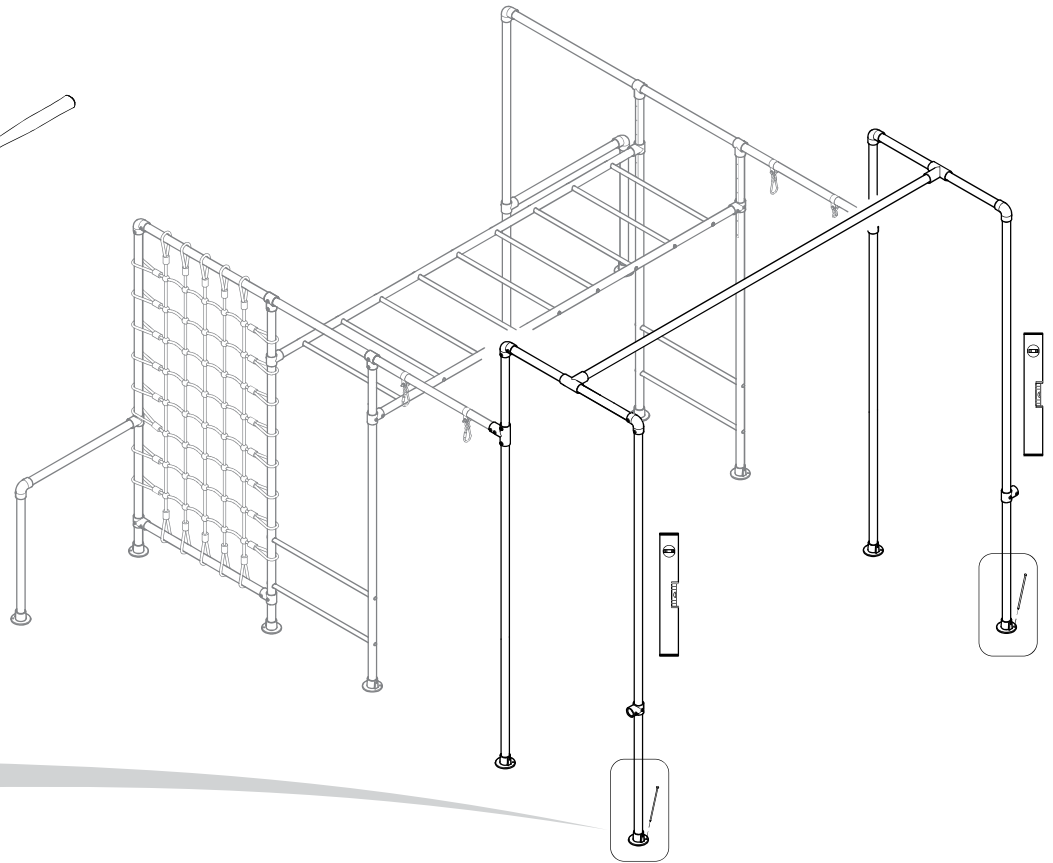
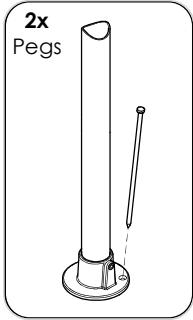

13 ATTACH TWIRLY WHIRLY BARS X2

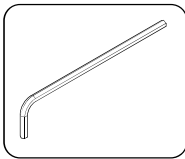

1. Adjust height and orientation of short tees A & B to align horizontally with twirly whirlys.

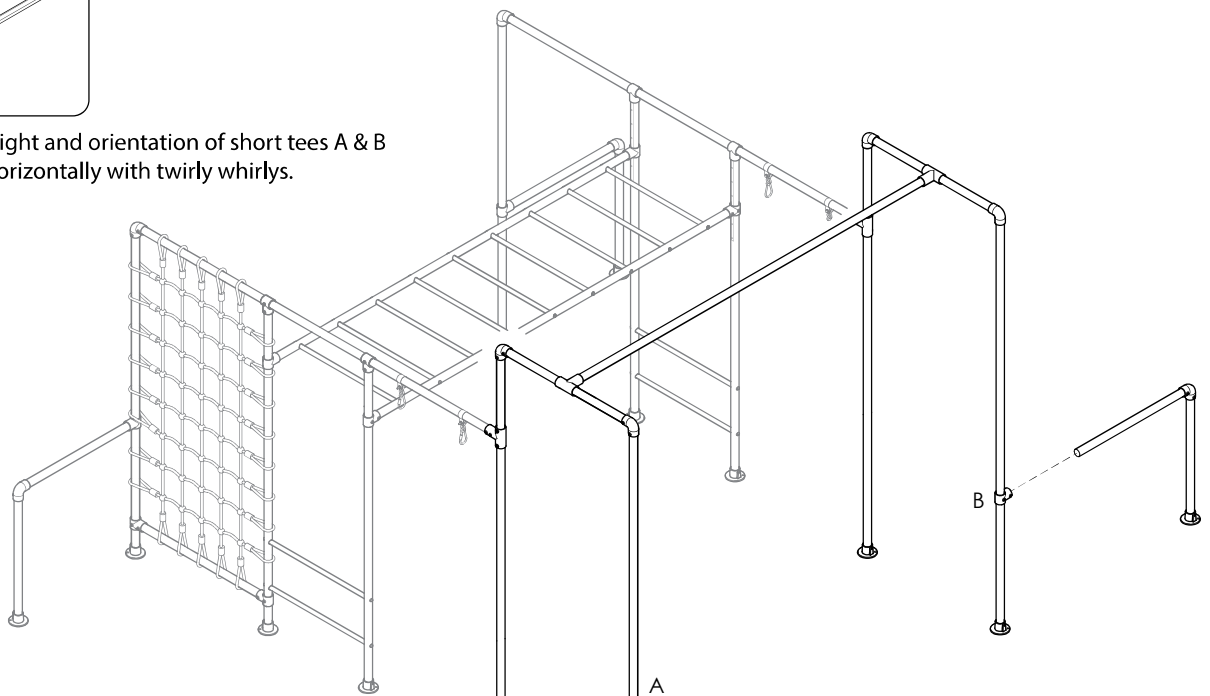

2. Attach twirly whirlys removed in step 2.
Fully tighten all grub screws.

Twirly whirly bars detached from step 2.

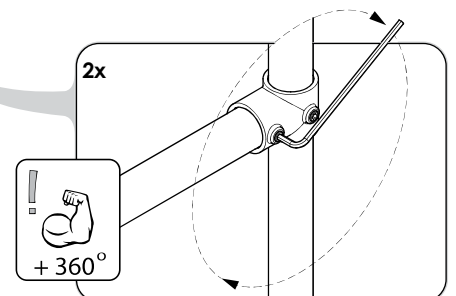

Tighten all grub screws.

14 LOAD YOUR TWIRLY WHIRLY BARS X2

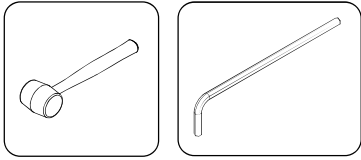

To reduce movement in your frame load your twirly whirly bars as follows.

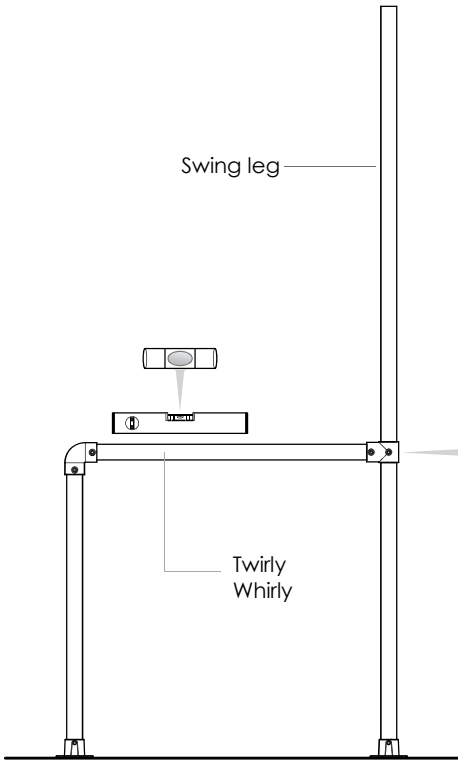

1. Ensure twirly whirly is level and square & swing leg is pegged down.

2. Loosen the grub screw fixing the short tee to the swing leg.

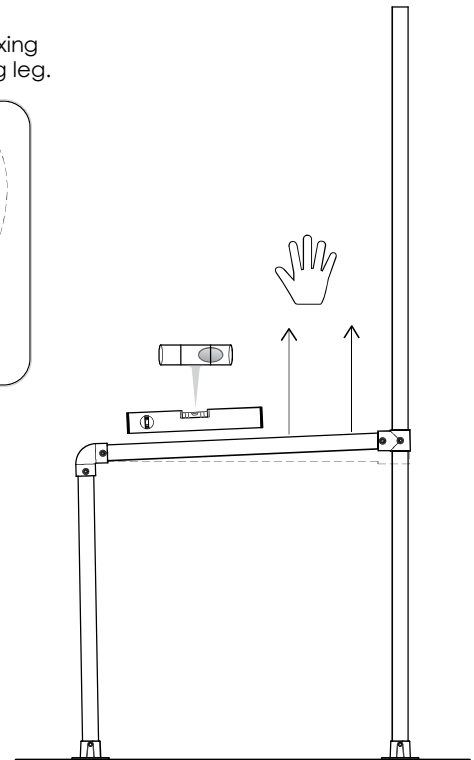
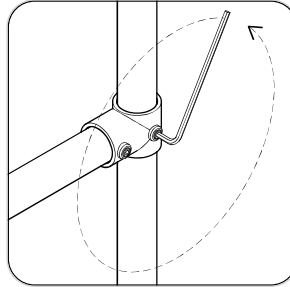

3. Pull upwards on the twirly whirly bar to make a slight angle. (Half a bubble off center on the level)

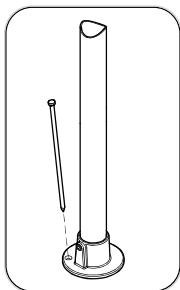

4. Peg down base plates on twirly whirly.

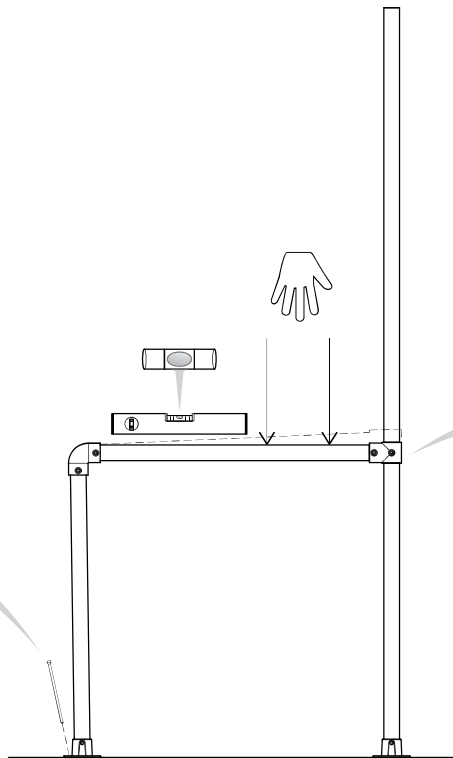

5. Push down on the twirly whirly bar until horizontal bar is level.

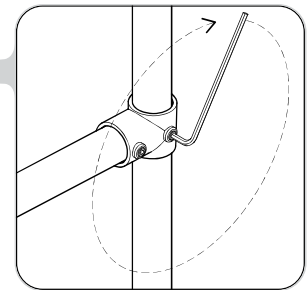

6. Tighten grub screw fixing the short tee to the swing leg tube.

REFER TO VIDEO SECTION OF WEBSITE [HTTP://WWW.FUNKYMONKEYBARS.COM/PAGES/VIDEOS](http://www.funkymonkeybars.com/pages/videos)

15 ATTACH ACCESSORIES (IF APPLICABLE)

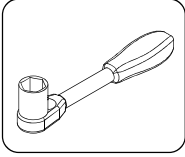

Attach new and existing accessories in desired position if applicable and tighten swing hook bolts with ratchet.

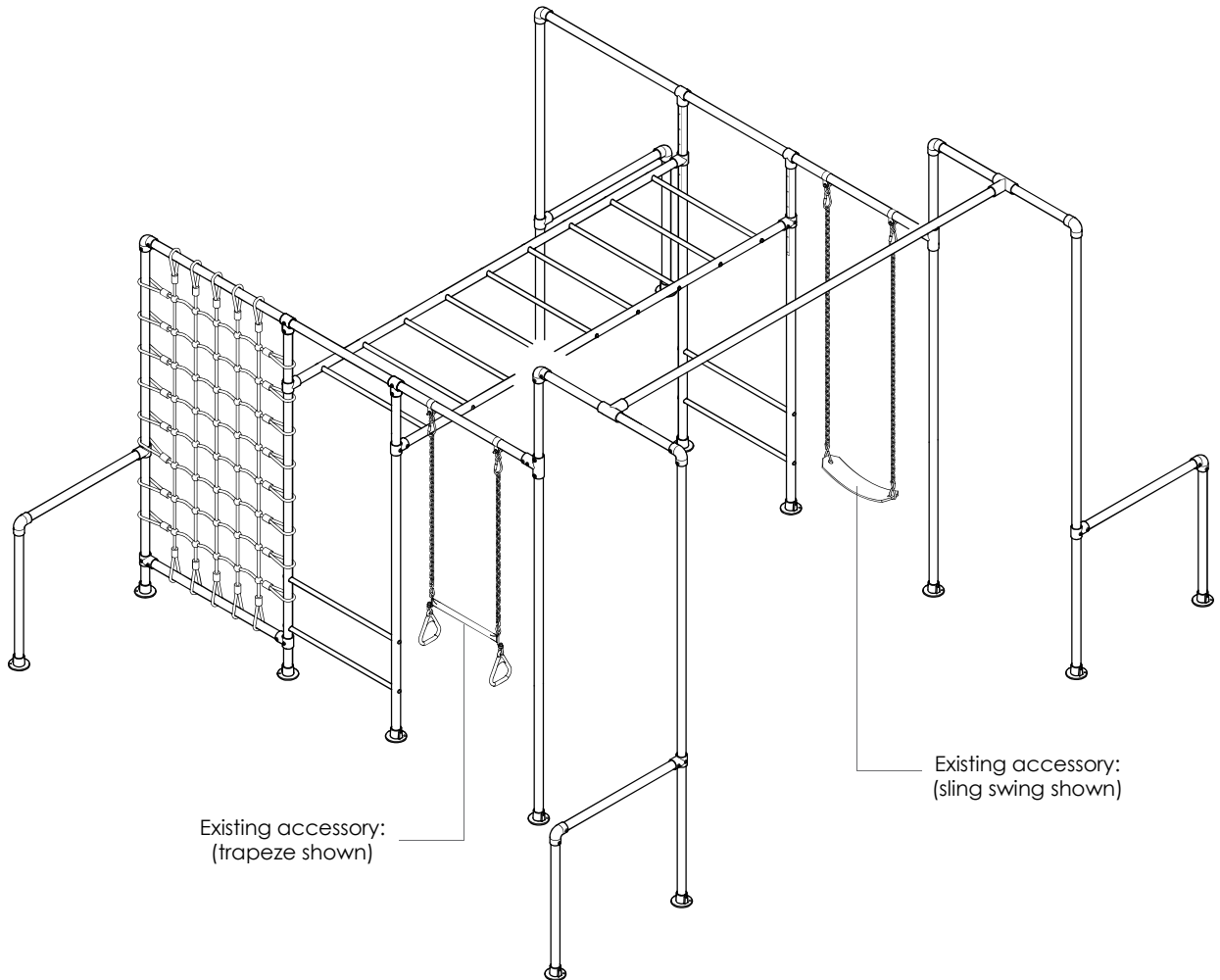

16 FINAL CHECKS

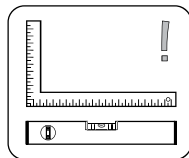
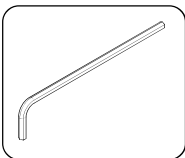

1. Ensure frame is square and level.
2. Firmly tighten all grub screws and bolts.
3. All base plates are pegged down.

17 MAINTENANCE.

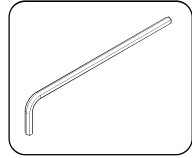
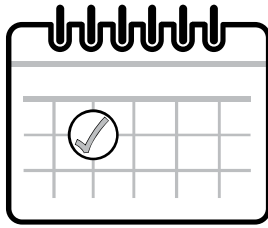

At the beginning of each heavy play session (especially a party) and twice a month during play season ensure;

1. Tighten all hardware - grub screws, nuts and bolts.
2. Pegs are in place and fully secure.
3. Lubricate all metallic moving parts with WD40 or Vaseline - (trolley and swing hooks.)
4. Ensure your frame is level and square.

FAILURE TO DO SO COULD RESULT IN SERIOUS INJURY OR DEATH.

**FOR MORE INFORMATION AND ASSEMBLY TIPS
PLEASE REFER TO OUR WEBSITE VIDEO INSTRUCTION SECTION AT
[HTTP://WWW.FUNKYMONKEYBARS.COM/PAGES/VIDEOS](http://www.funkymonkeybars.com/pages/videos)**

18 HAVE FUN



NOTES.



ABN 72 164 496 520



1300 912 198



info@funkymonkeybars.com



www.funkymonkeybars.com



9 Cutting Way,
Yangebup WA 6164



WE ARE SOCIAL MONKEYS



Australian Government
IP Australia

All Funky Monkey Bars® designs are registered and protected under IP Australia certification.