

FUNKY Monkey bars®

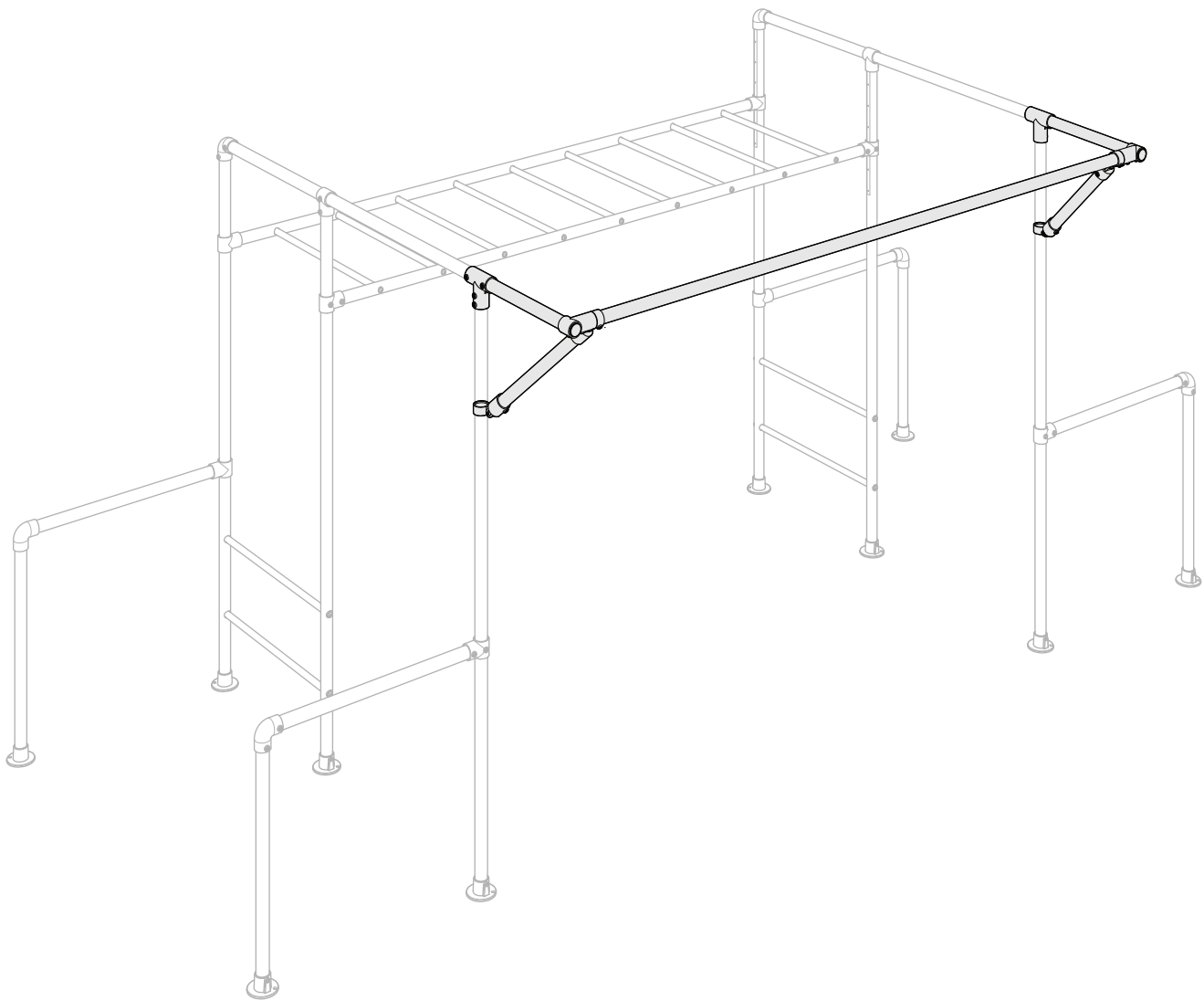

FLOATING ACCESSORIES BAR (ADD ON) ASSEMBLY INSTRUCTIONS

CONTENTS

Warnings	Page 1
Load Rating	Page 3
Assembly Tips	Page 4
Inventory	Page 6
Assembly Instructions	Page 7
Maintenance	Page 15

WARNING

PLEASE CAREFULLY READ ALL INFORMATION CONTAINED IN THIS ASSEMBLY MANUAL BEFORE YOU INSTALL AND USE YOUR FLOATING FLYING FOX.

SAFETY NOTICE

1. Any person handling or using the Funky Monkey Bars® products must follow the instructions as described in this document. The person in charge of assembling and using the equipment must ensure that the recommendations for use given in this document are seen by all users.
2. Only use the Funky Monkey Bars® after they have been fully assembled and after checking that the fittings are tightened properly (*refer to page 4 - Correct Tightening Method*).
3. DO NOT install your Funky Monkey Bars® over concrete, asphalt, packed earth, wood decking or any other hard surface. A fall onto a hard surface can result in serious injury or death.
4. Inspect all grub screws, bolts and nuts at the beginning of each play session to ensure your Funky Monkey Bars® are tight and secure.
5. Ensure all tubes are fully inserted into fittings until you hear the magic "CLUNK" sound.
6. Ensure your Funky Monkey Bars® are properly secure at ALL times. Pegs are in place and inserted fully into the ground.
7. DO NOT exceed the maximum load/weight limit as recommended by Funky Monkey Bars®.
8. Children should be supervised by an adult at all times.
9. Installing a gym/crash mat under the fall zone area of your Funky Monkey Bars® would be recommended for children learning this new skill. This will reduce the chance of injury and build the child's confidence while they build strength and master the skill.
10. Ensure you have thoroughly read your assembly and installation instructions and viewed our on-line installation videos at <https://www.funkymonkeybars.com/blogs/installation-maintenance-videos>
11. DO NOT climb, sit or stand on top of the monkey bar (horizontal ladder) section.
12. DO NOT jump from the top of any section of the monkey bar.
13. DO NOT use your Funky Monkey Bars® when wet as the steel will be slippery.
14. DO NOT attach items to your frame that are not designed specifically to be used with Funky Monkey Bars®. Especially lower quality products that have not been approved by Funky Monkey Bars®.
15. Ensure the height of your Funky Monkey Bars® (horizontal ladder) are set at a level that is age appropriate.
16. DO NOT install your Funky Monkey Bars® over or near objects that could interfere with users in an unsafe way. Maintain a clear area around your Funky Monkey Bars®.
17. DO NOT use your Funky Monkey Bars® while under the influence of drugs and alcohol.
18. Wear clothing free of drawstrings, hooks, loops or anything that could get caught while using your Funky Monkey Bars® and result in entanglement and/or strangulation.

ASSEMBLY

1. Keep small children away from the Funky Monkey Bars® when assembling the Floating Accessories Bar.
2. Do not attempt to use the Funky Monkey Bars® or the Floating Accessories Bar until it is completely assembled and every fitting is tight and secured.
3. Installation typically takes 1-2 hours to complete. Two people are recommended for assembly.
4. Ensure all fittings are tightened to the correct tightening method as described on page 4.
5. Assembly should be carried out on clean, dry, level surface.

Please refer to the video section on the Funky Monkey Bars® website for more handy tips and assembly instructions at <http://www.funkymonkeybars.com/pages/videos>

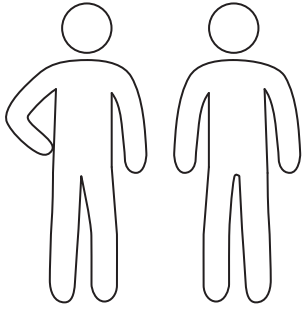

Assembly requires 2 adults.

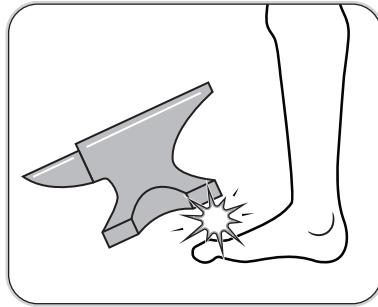

Heavy items !

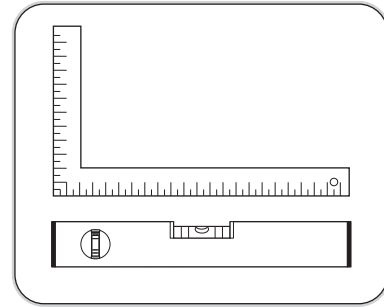

Work on flat level surface.

LOCATION

1. A safe fall zone around your Funky Monkey Bars® is essential. A minimum distance of 1.5m to 2m (5 ft to 6.5ft) is recommended around the elevated hanging points of your Funky Monkey Bars®.
2. Place your Funky Monkey Bars® on level ground, away from any structure or obstruction such as a fence, garage, house, overhanging branches, laundry lines or electrical wires and remove any obstructions beneath your Funky Monkey Bars®.
3. Ensure your Funky Monkey Bars® are positioned away from retaining walls, pool fences, structures and other play equipment. Maintain a clear space around the whole perimeter of your Funky Monkey Bars®.
4. Place your Funky Monkey Bars® on the most level surface available.

MAINTENANCE

1. At the beginning of each heavy play session we recommend the following maintenance processes be performed on your Funky Monkey Bars®:
 - Tighten all bolts, grub screws and applicable hardware (as per page 4)
 - Lubricate all metallic moving parts as per instructions (flying fox, swing hooks etc)
 - Check all protective coverings on bolts, pipes, edges and corners. Replace if they are loose, cracked or missing.
 - Check all moving parts including swing seats, shackles, snap hooks, chains and trolleys for wear, rust, or other deterioration. Replace as needed.
2. Twice a month during play season we would recommend the following maintenance processes be performed on your Funky Monkey Bars®:
 - Tighten all connections and hardware
 - Check all protective coverings on bolts, pipes, edges and corners. Replace if they are loose, cracked or missing.
3. Once a month during play season we would recommend the following maintenance processes be performed on your Funky Monkey Bars®:
 - Lubricate all metallic moving parts as per instructions (flying fox, swing hooks etc). If swings start to squeak then lubricate swing hooks.
 - Check all moving parts including swing seats, ropes, chains and trolleys for wear, rust, or other deterioration. Replace as needed.
 - Owners shall be responsible for maintaining the legibility of any warning labels.

For additional information concerning your Funky Monkey Bars®, please contact our customer service team or check our website for any important updates. Phone: 1300 912 198 or www.funkymonkeybars.com



QUALITY & INDEPENDENT TESTING

At Funky Monkey Bars® we take the quality of our designs and safety very seriously. All Funky Monkey Bars® frames go through a stringent, independent structural testing process prior to being made available for release to our customers.

Our frames are designed within the parameters of the Australian Standard for Playground Equipment AS4685.1:2014.

The structural integrity of our frames has been tested for performance through a combination of engineering calculations and physical testing. The tests have been performed by independent, certified structural engineers in accordance with Australian Standard for Playground Equipment AS4685.1:2014 and European Standards EN1176-1:2008.

The independent testing conducted on The Floating Flying Fox certified the frame to a load rating of 130kgs or 1 user.

LOAD TESTING CERTIFICATION				
DATE OF TEST	MODEL	NUMBER OF USERS	USER LOAD (KG)	LOAD RATING (KG)
May 2018	Floating Accessories Bar	1	69.5	130
I hereby confirm all testing was undertaken in accordance with Physical Testing of Structural Integrity requirements of AS 4685.1: 2014 App C / EN 1176-1:2008* except where noted below;				
COMMENTS:				
- The maximum number of users for the Floating Flying Fox is noted as 1 user.				
APPROVED BY: Funky Monkey Bars®  DATE : May 2018			WITNESSED BY: Independent Engineer  DATE : May 2018	

ASSEMBLY TIPS

CORRECT INSERTION INTO FITTINGS

All tubes must be fully inserted until contact is made with adjoining tube.

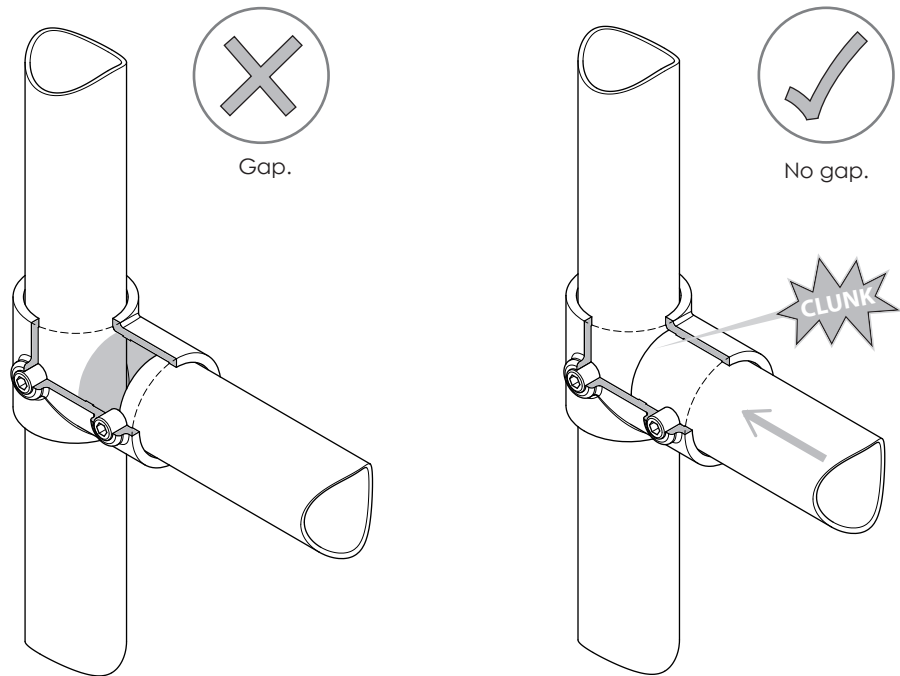

CORRECT TIGHTENING METHOD OF GRUB SCREWS

1. With long end of allen key, hand tighten grub screw as much as possible.



2. Using other end of the allen key do one full 360 degree turn as a minimum, use muscles!

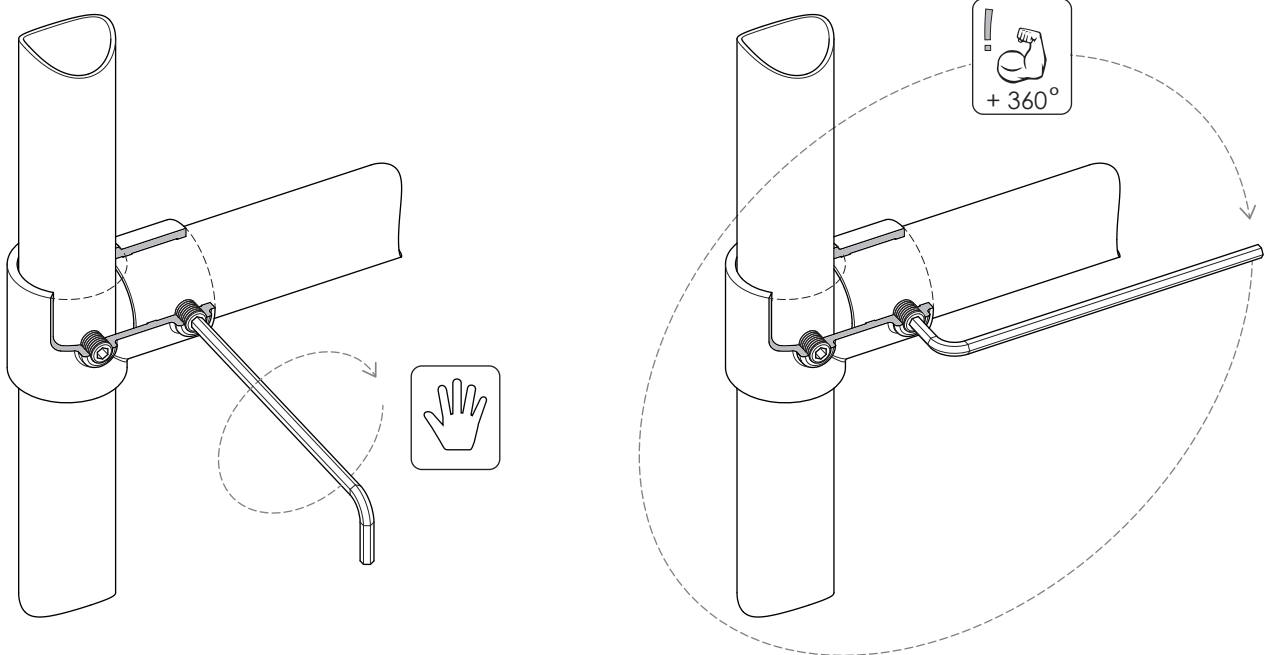

ASSEMBLY TIPS (CONTINUED)

IT IS CRITICAL YOUR MAIN FRAME IS 100% SQUARE AND LEVEL

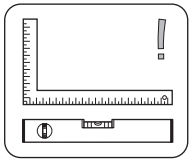

Check assembly is 100% level, square & straight.

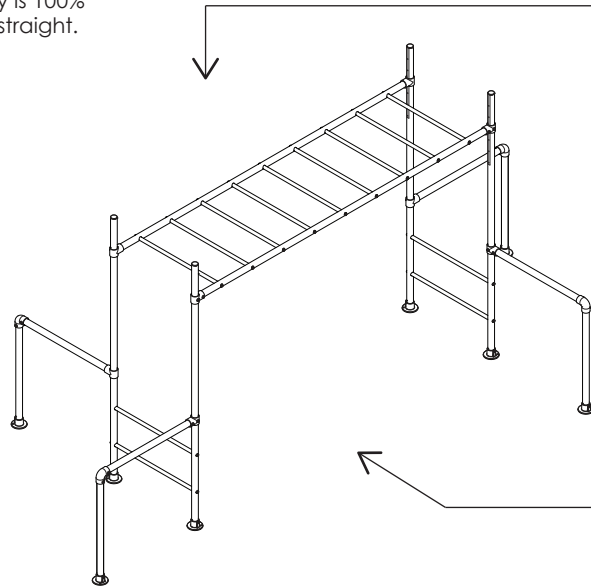

PLAN VIEW

SIDE VIEW

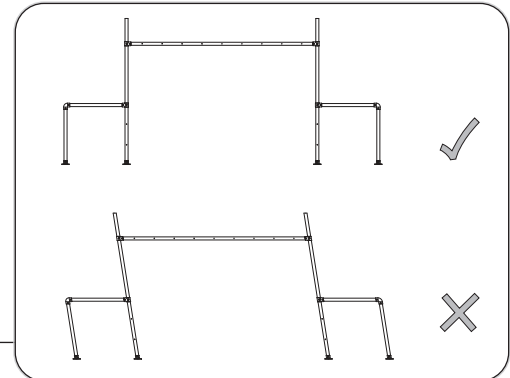
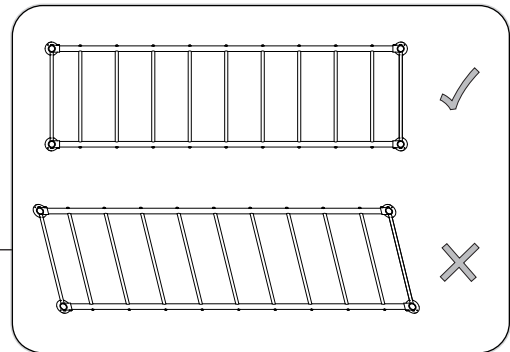

If your frame is not straight or level remove pegs, loosen grub screws, re-adjust re-tighten and re-peg the frame.

INSTALLATION ON A SLOPE

If your frame is being installed on a slope ensure the monkey ladder bar is level. Either install at different heights on the legs or dig down at one end until level.

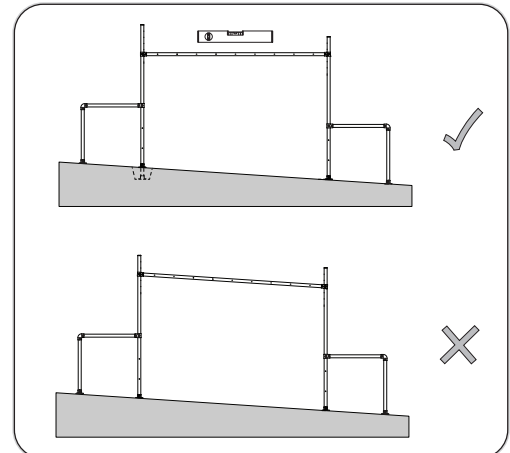

FIXING TYPICAL ORIENTATION

Unless otherwise stated all grub screws and fittings should face downwards and outwards. This will reduce weathering damage, help with assembly and ease of maintenance.

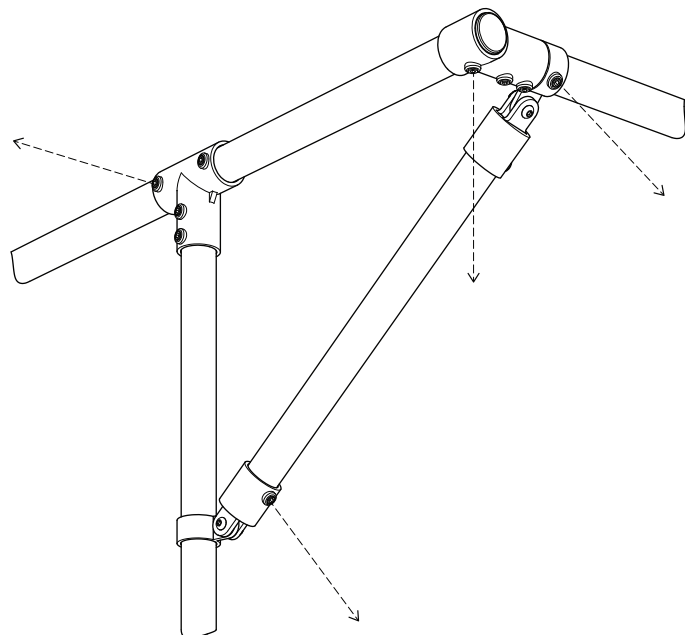

INVENTORY

TOOLS REQUIRED FOR INSTALLATION

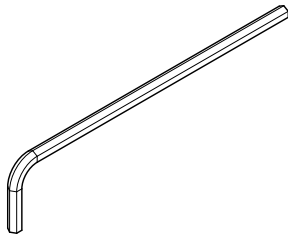

1x
8mm Allen key
(included)

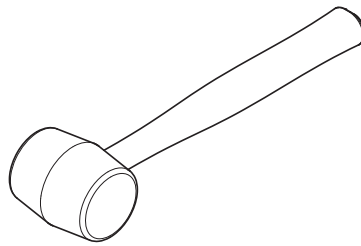

1x
Soft Hammer
(not included)

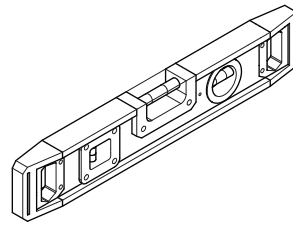

1x
Spirit Level
(not included)

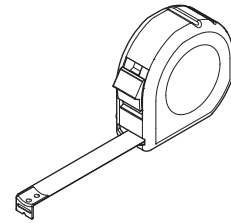

1x
Tape Measure
(not included)

TUBES



FITTINGS

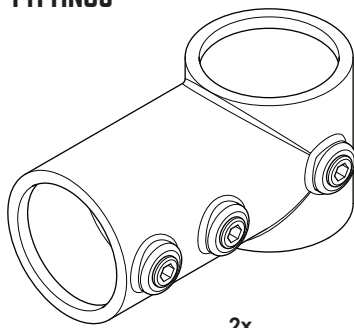

2x
Long Short Tee
D-101L

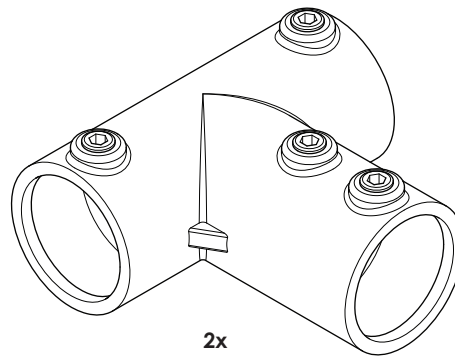

2x
Extra Long Tee
D-104L

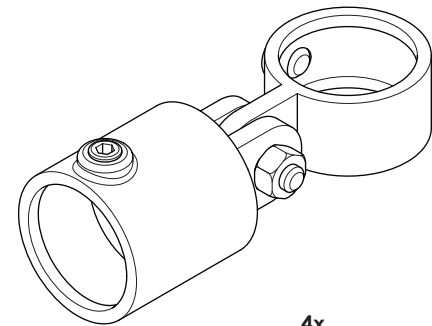

4x
Swivel Brace
D-173

COMPONENTS

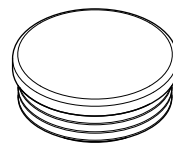

2x
Plastic End Cap

One of the best things about Funky Monkey Bars® is the ability to add new equipment and accessories as your child and family grows. You can swap or add accessories to your existing frame, or add extra frames that will give you more versatility to attach equipment. Check out what we've got in store now at...

WWW.FUNKYMONKEYBARS.COM

ASSEMBLY INSTRUCTIONS

1 FLOATING ACCESSORIES BAR RECOMMENDED POSITION

The Orangutan model shown for demonstration purposes.

Ladder side
(Short tees A & B may need to be temporarily removed if the monkey ladder needs to be higher)

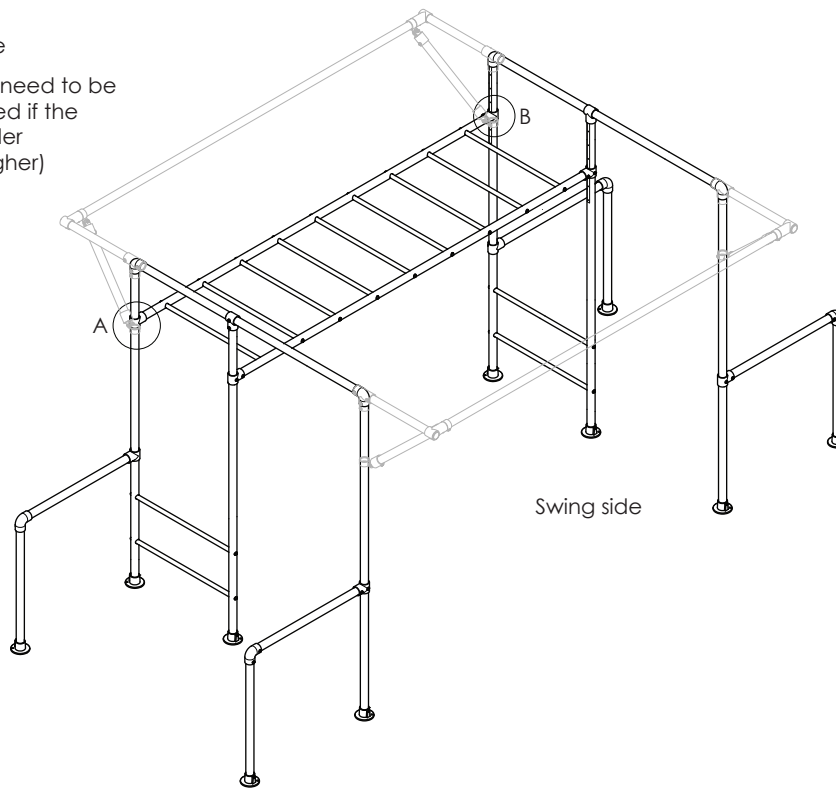

NOTE: The Floating Accessories Bar can be assembled on either side of the frame. Funky Monkey Bars® recommends positioning the Floating Accessories Bar on the opposite side to the monkey bar ladder for improved structural integrity and ease of assembly.

2 PRECHECK

It is critical that your frame is level and square prior to installing your Floating Accessories Bar. Please check dimensions as per below and realign frame if necessary.

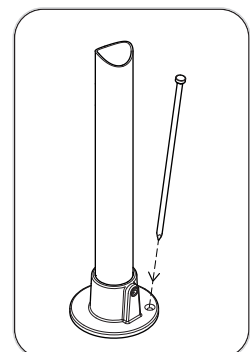
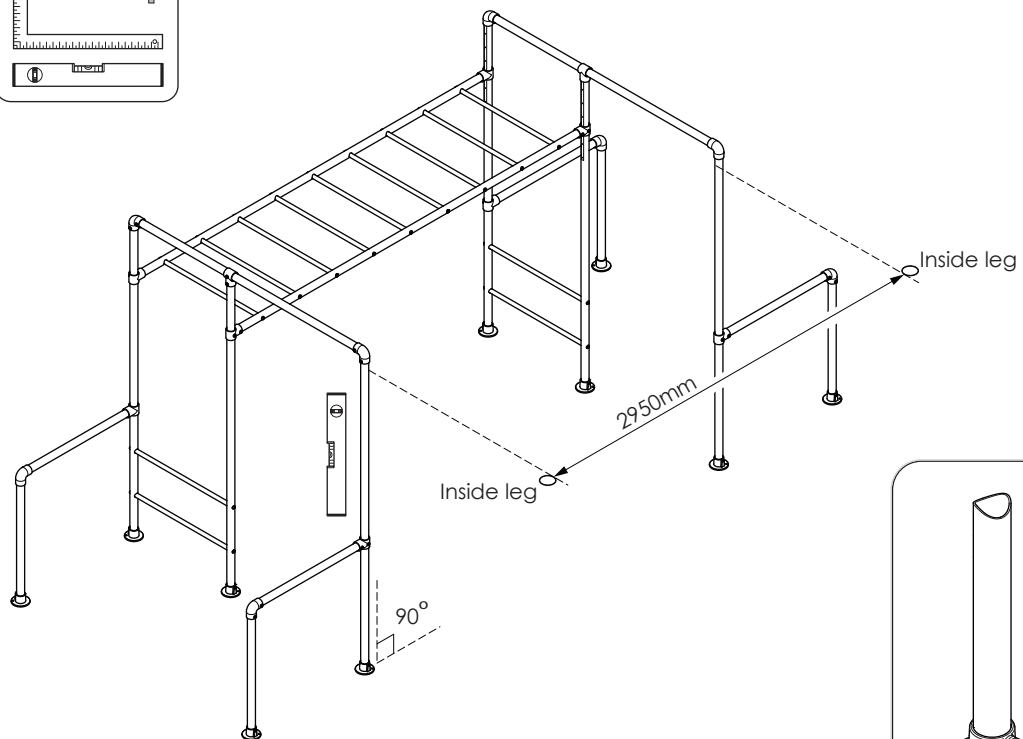
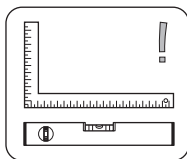
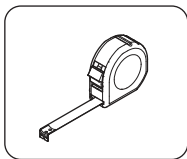

Ensure frame is fully pegged down.

3 ASSEMBLE EXTENSION TUBES & TIGHTEN

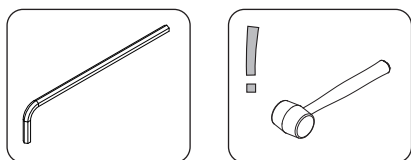

1. Tap end caps into extension tube ends.
2. Insert extension tubes half way into extra long tees and fully tighten all grub screws.

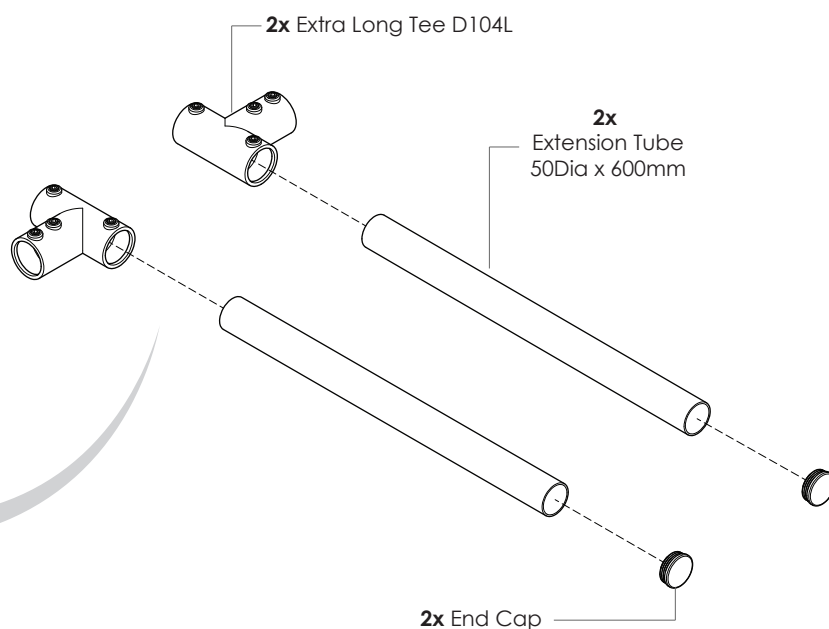
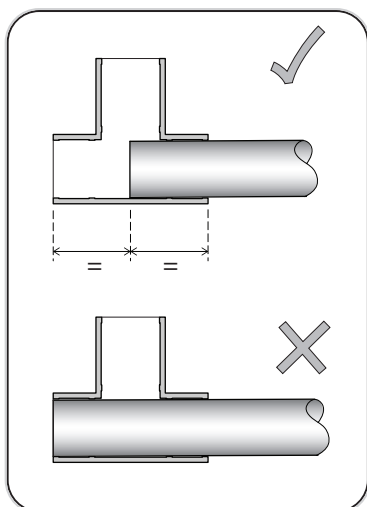
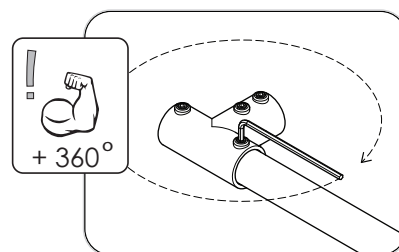

4 REMOVE PEGS & LOOSEN ELBOWS

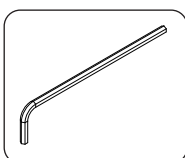

Remove pegs from base plates on selected floating accessories bar side.

Loosen elbow grub screws connecting swing legs to swing bar on same side.

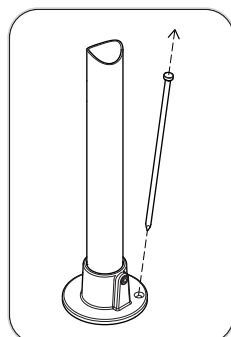

Remove pegs x4

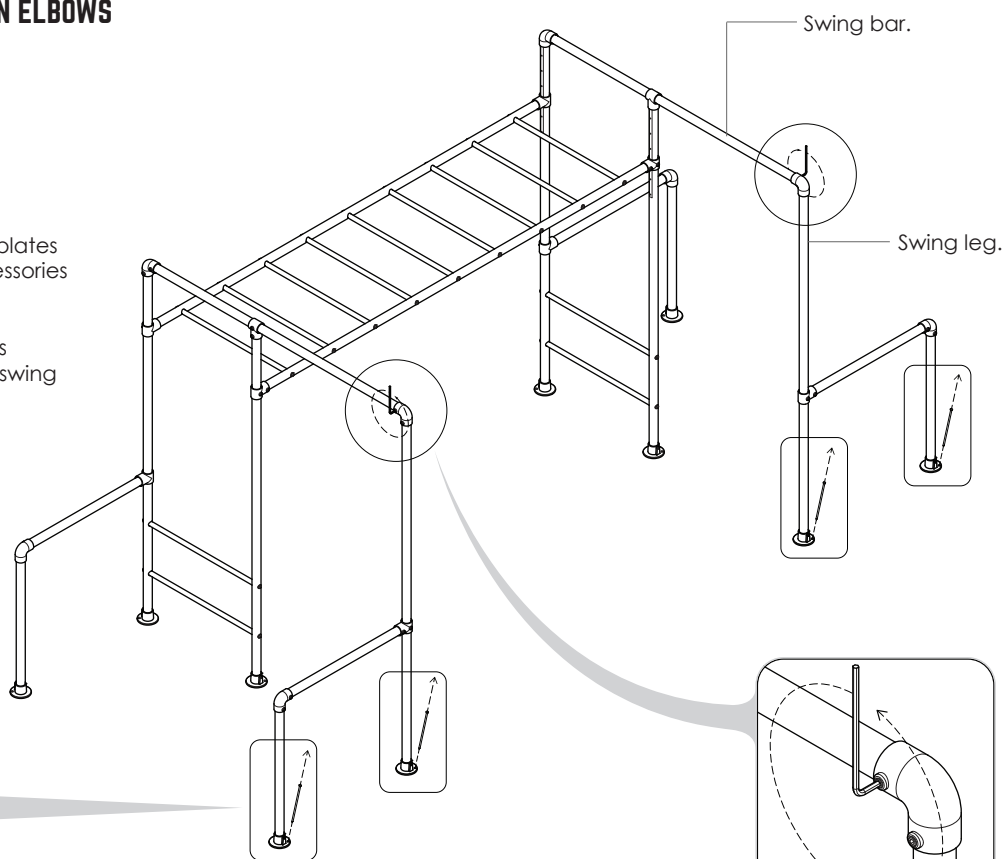

Loosen elbow grub screws.

5 REMOVE SWING LEGS & ELBOWS

1. Lay swing legs on the ground.
2. Remove leg elbows x2.

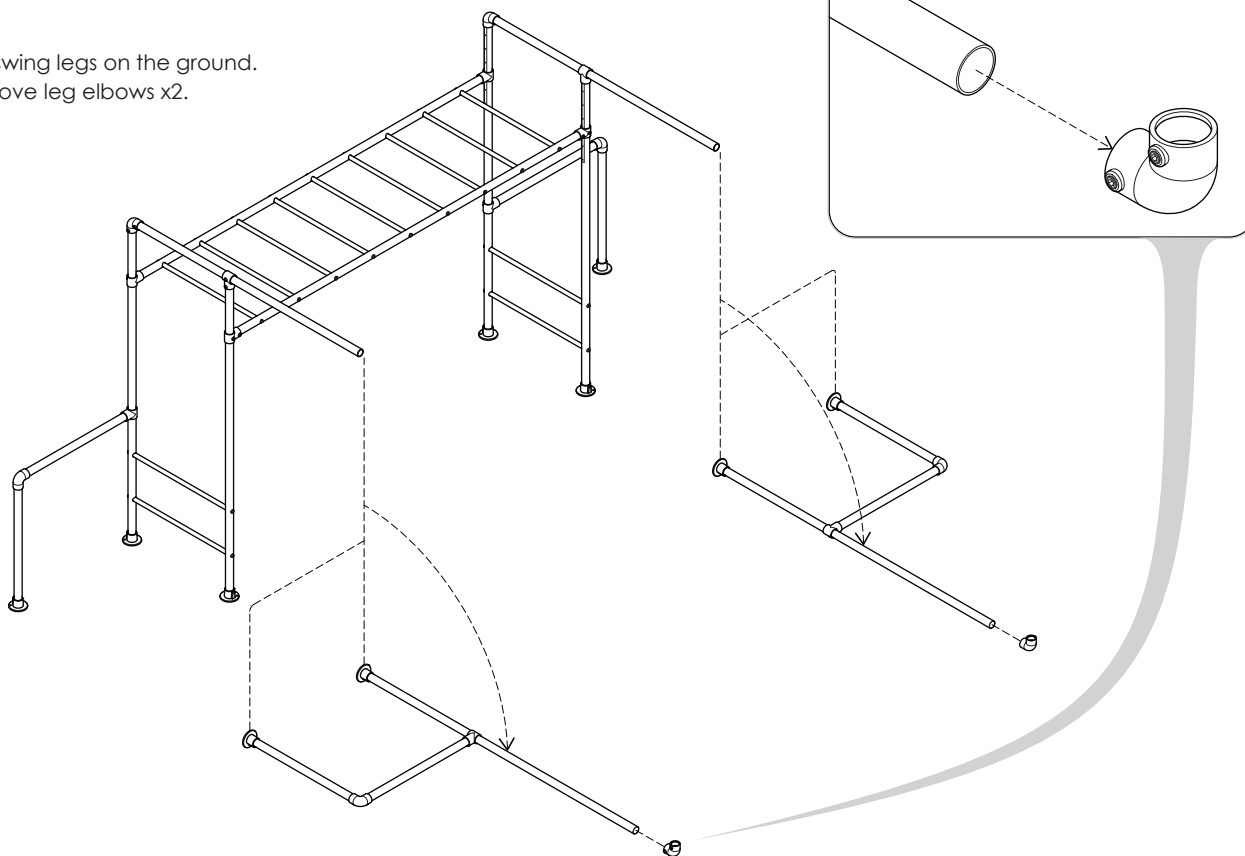

6 CONNECT EXTENSION TUBES TO EXISTING LEGS x2

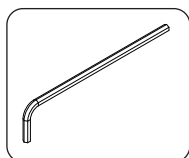

1. Slide swivel braces onto lowered legs ensuring the grub screws are facing the base plate, leave hand tight for later adjustment.
2. Attach extension tube. Ensure inserted leg (A) hits extension tube (B). Firmly tighten grub screws & repeat both sides. Leave swivel brace (C) loose on leg.

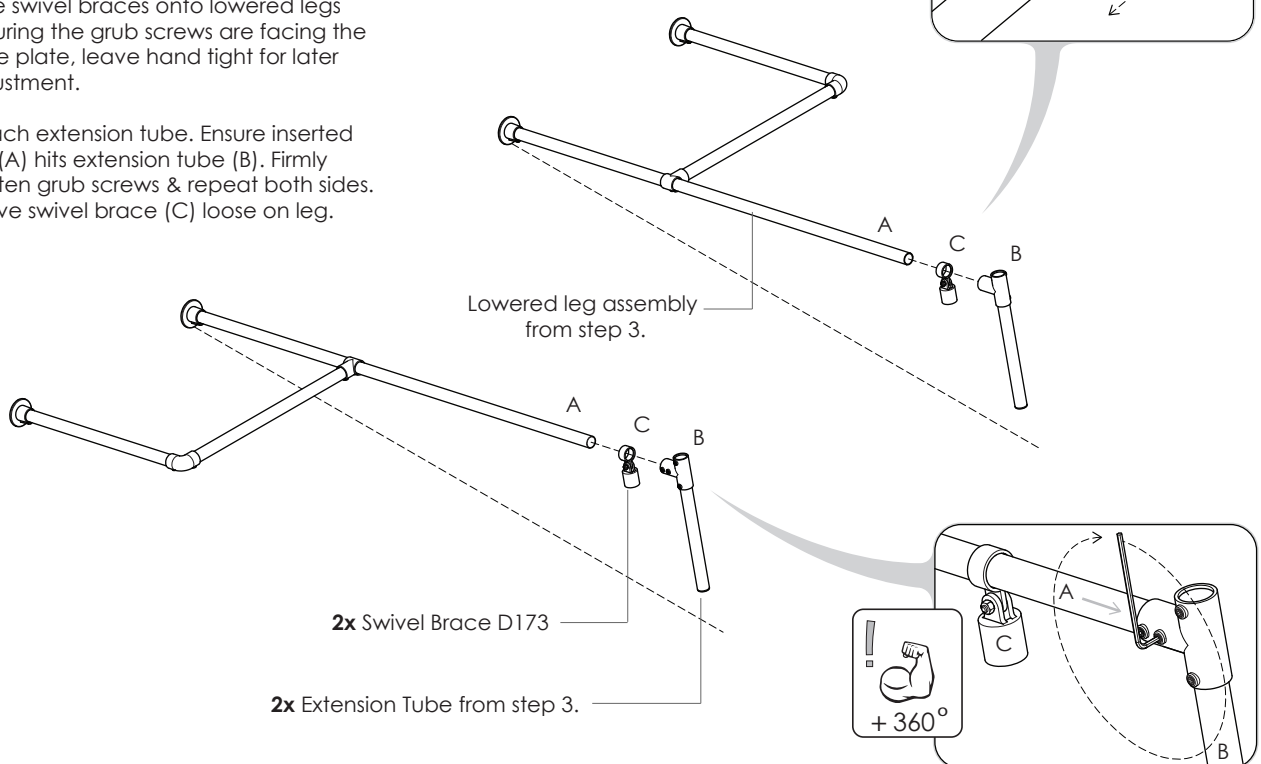

7 ASSEMBLE FLOATING ACCESSORIES FRAME

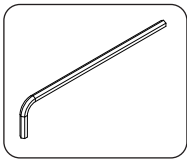

1. Space swing hooks (not included) if applicable along accessories tube as determined by your additional purchased components.

NOTE:

The number of swing hooks may vary according to the individual components you are adding to the accessories bar. Swing hooks are supplied with accessories. Refer to individual components for maximum load on accessories bar.

2. Slide swivel braces onto accessories tube.
3. Slide long short tees onto assembled legs from step 6. Insert the accessories tube into the long short tees and make sure the tube is butted up 100% to the extension tube as per detail below.
4. After hearing the clunk sound firmly tighten grub screws on long short tees. Leave swivel brace loose for later adjustment.

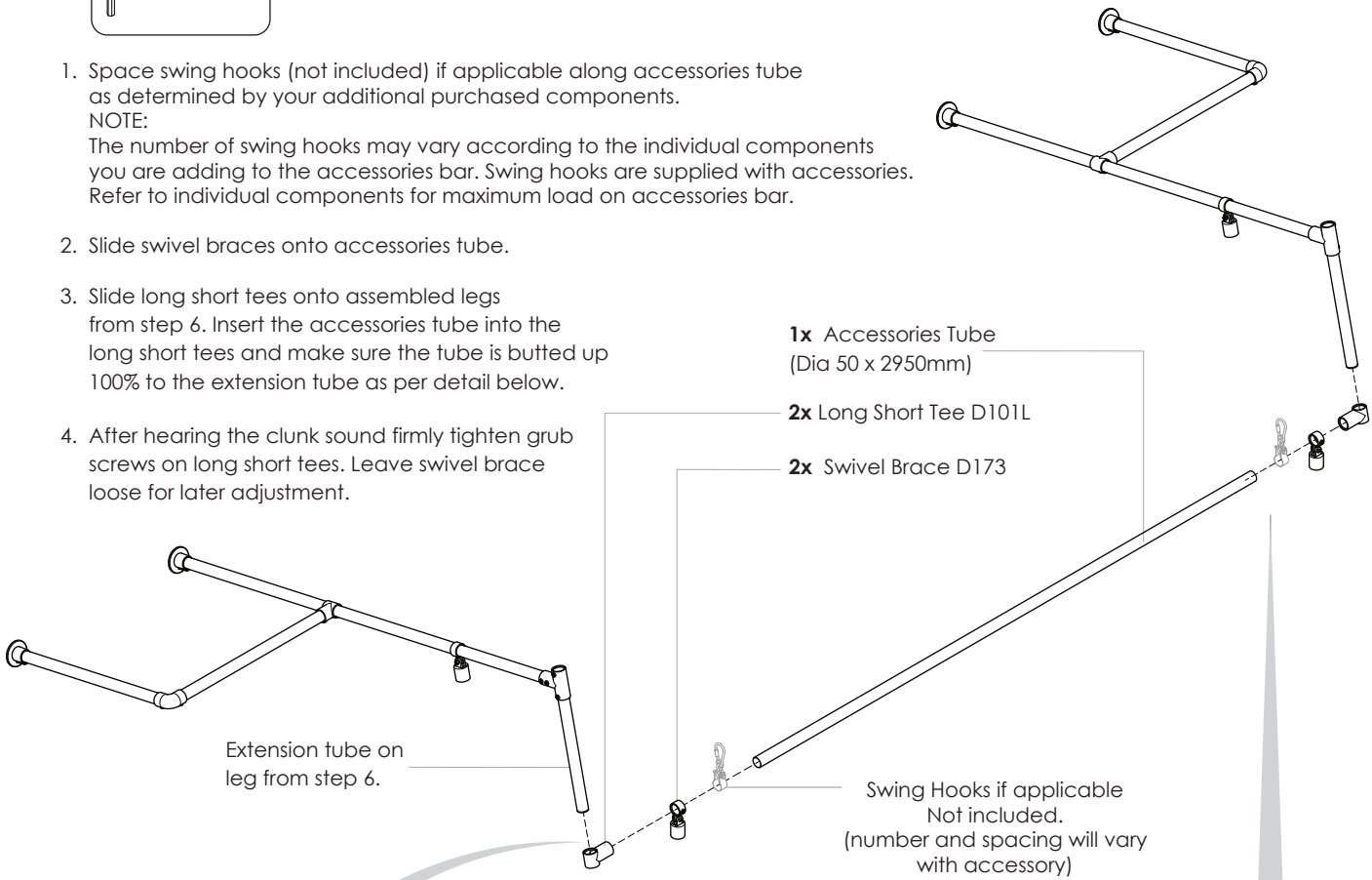

Extension tube on leg from step 6.

Swing Hooks if applicable
Not included.
(number and spacing will vary with accessory)

Leave swivel brace loose.

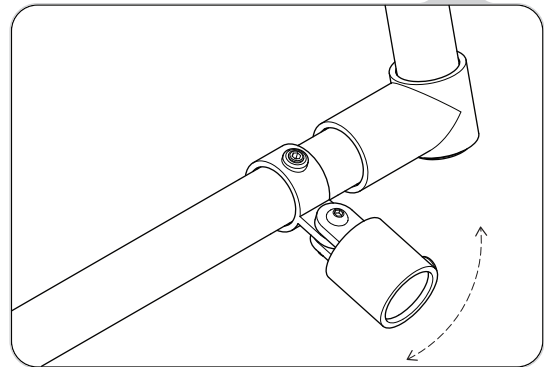

Firmly tighten all extra long tee grub screws.

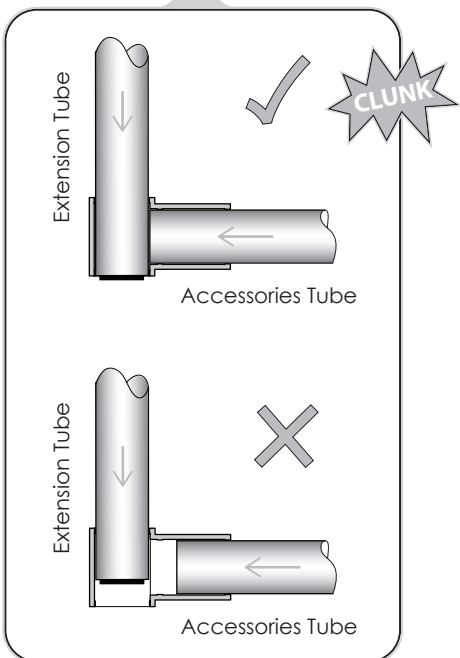
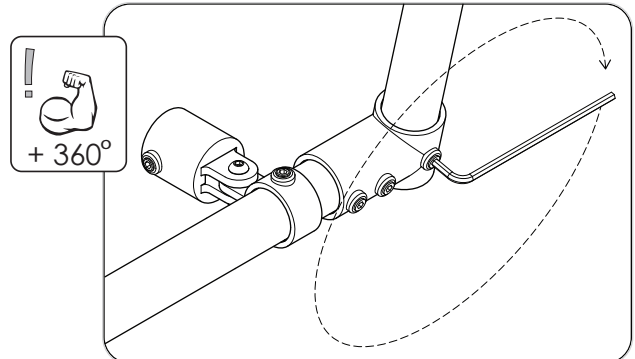

8 CONNECT THE BRACE TUBES.

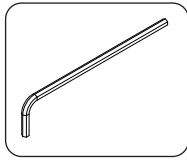

Fit 2x 600mm brace tubes into position by rotating and sliding swivel brace fittings.

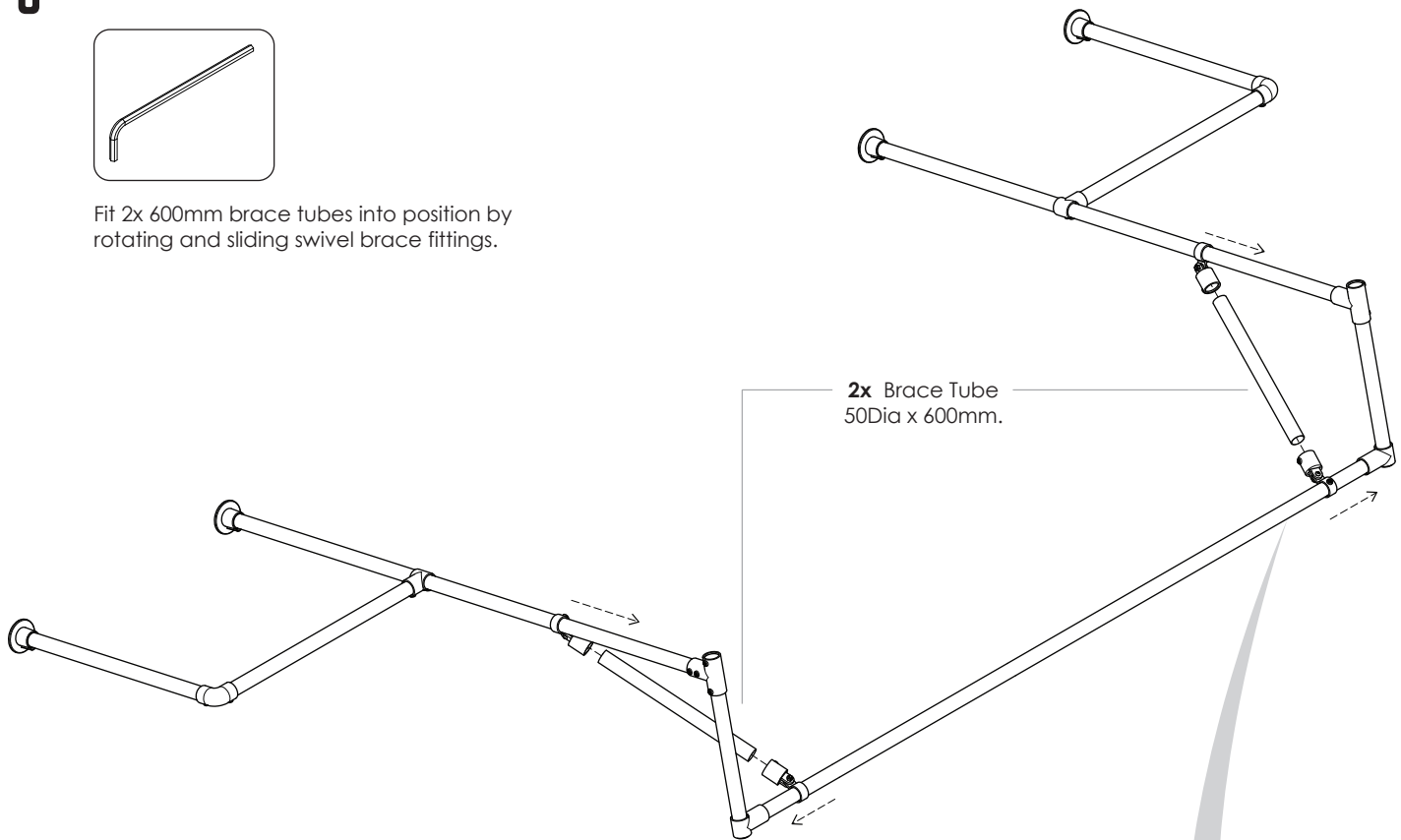

ORDER OF STEPS:

1. Slide brace tubes into swivel braces (A) & (B).
2. Tighten grub screws on (A) & (B).
3. Slide (D) hard up against long short tee (X).
4. Tighten grub screw on (D)
4. Slide (C) towards extra long tee (Y).
5. Tighten grub screws on (C) whilst pushing (C) towards (Y).

APPLY TO BOTH ENDS

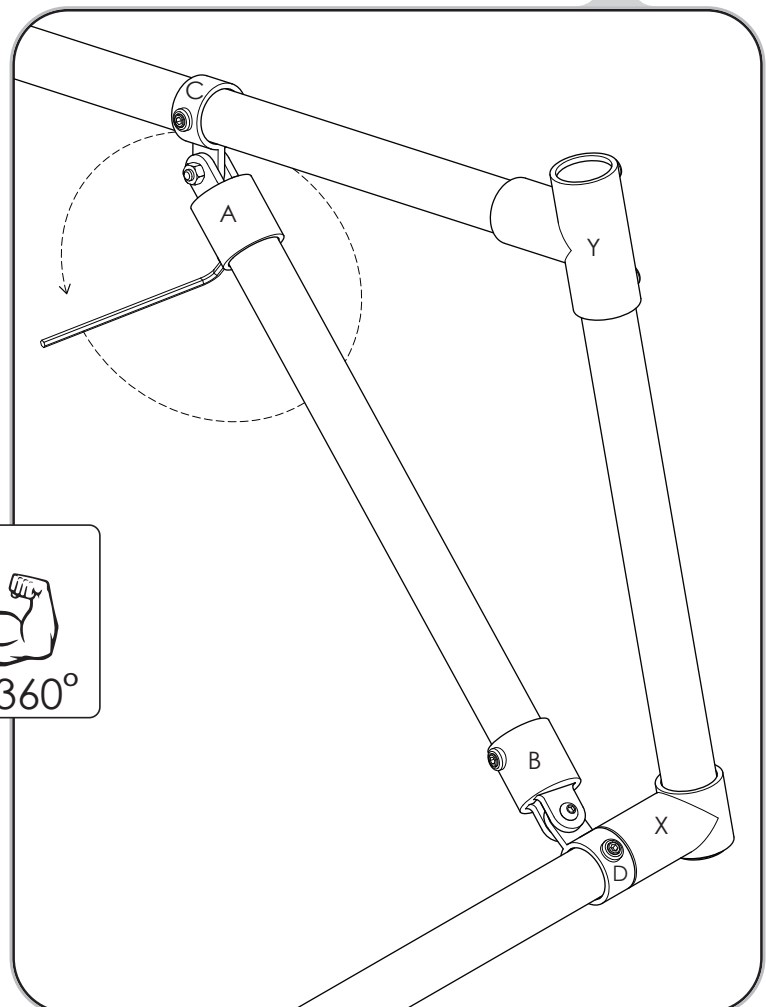

9 LIFT FLOATING ACCESSORIES FRAME INTO POSITION.

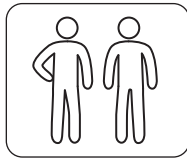
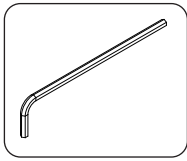

With two people lift floating accessories frame assembly into position and fully tighten grub screws on extra long tees.

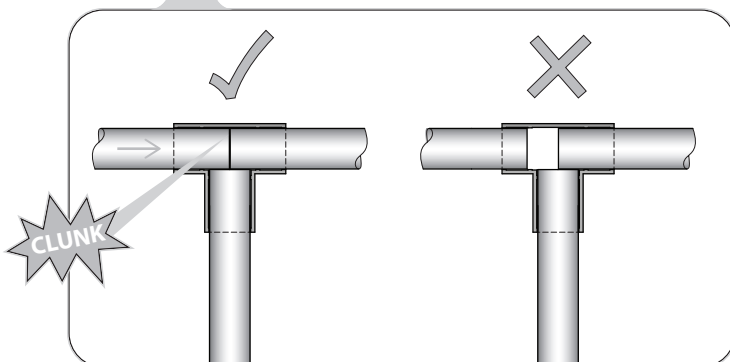
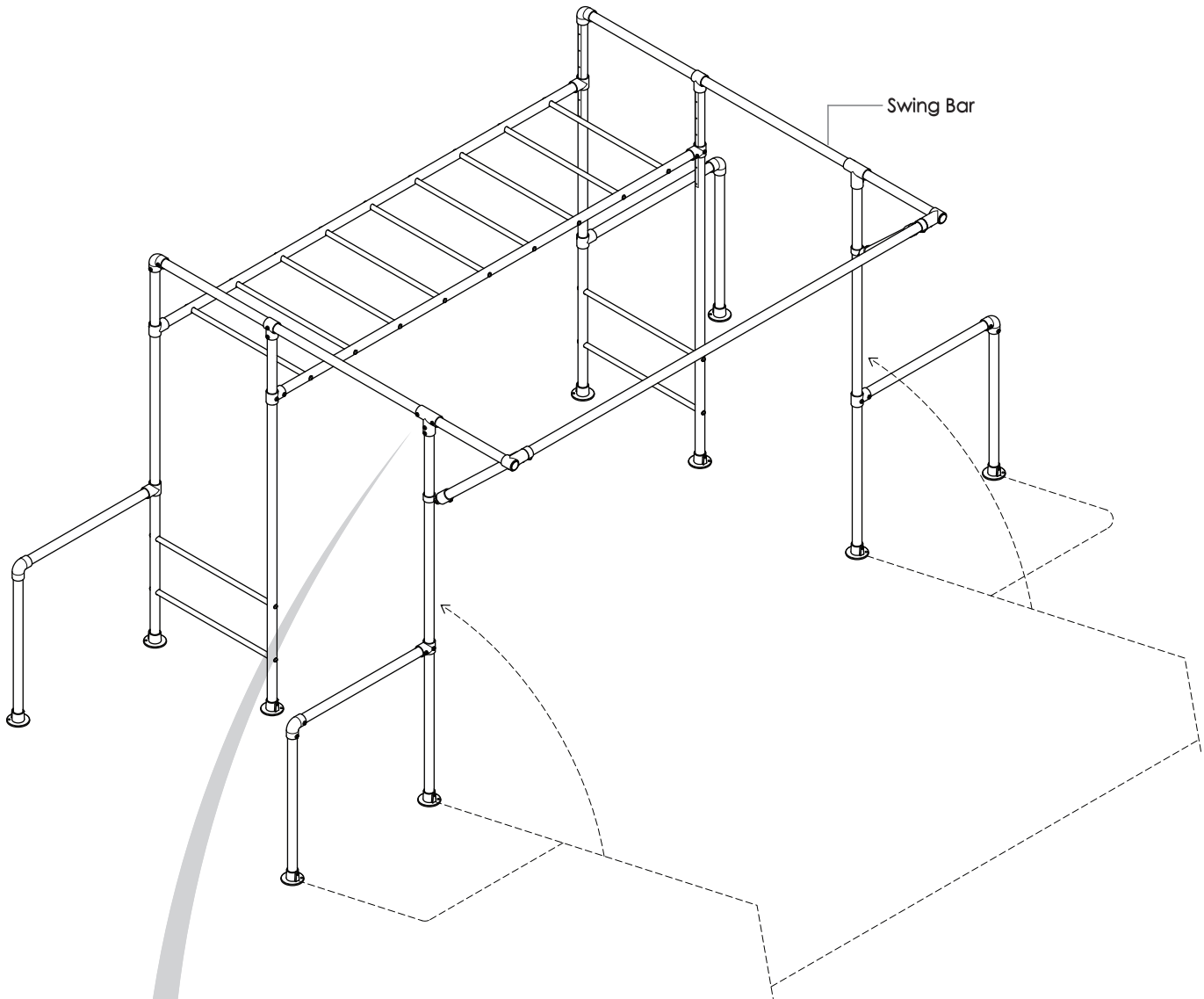

Ensure swing bar is fully engaged into extra long tee.

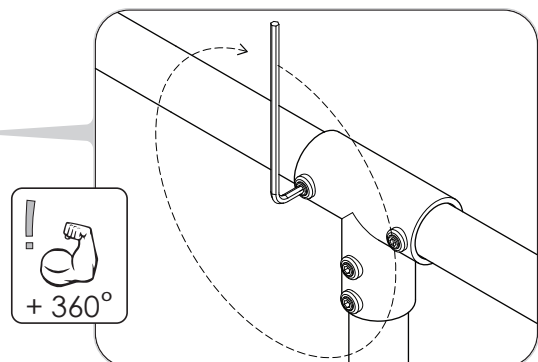

Fully tighten extra long tee grub screws both ends.

10 SECURE TO GROUND

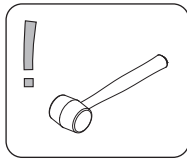
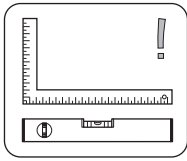

1. Check level and square.
2. Hammer in all removed pegs.

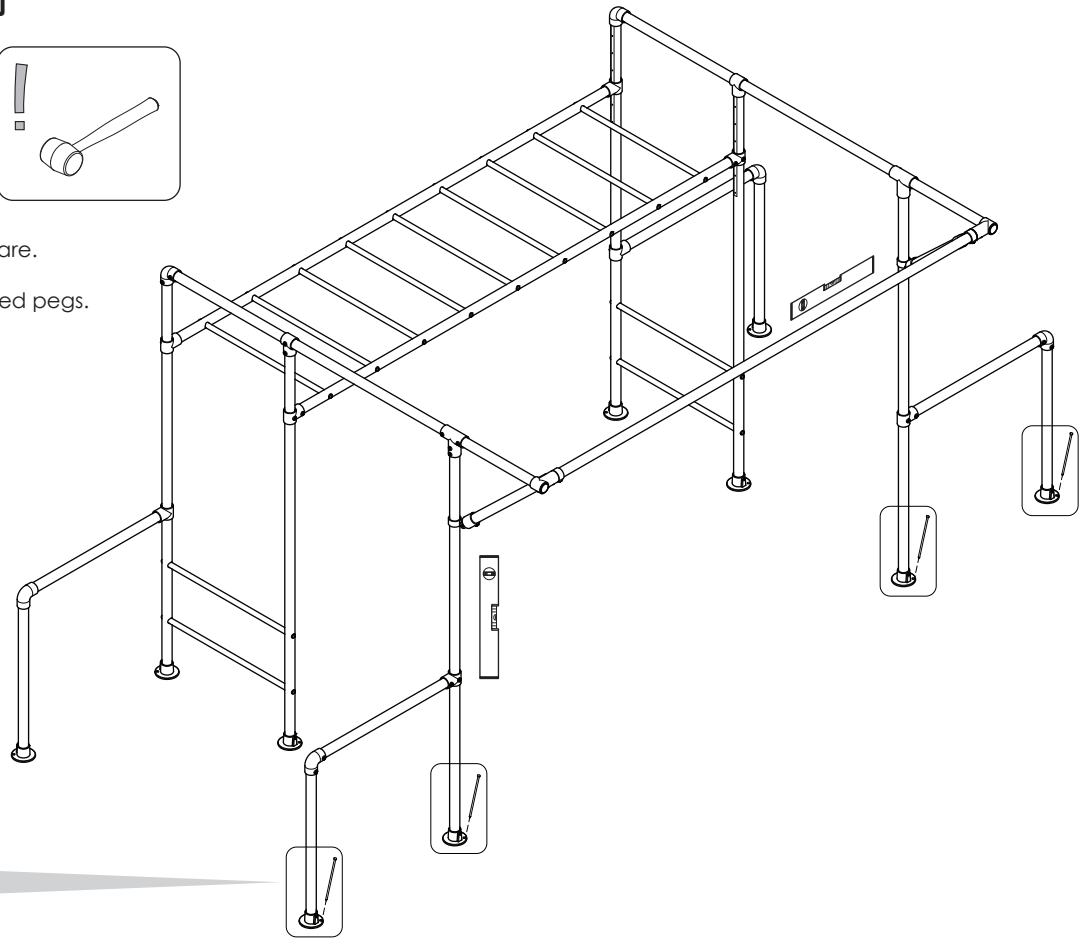

Hammer in pegs x 4.

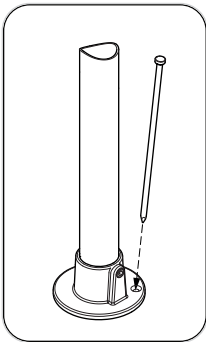

11 FINAL CHECKS

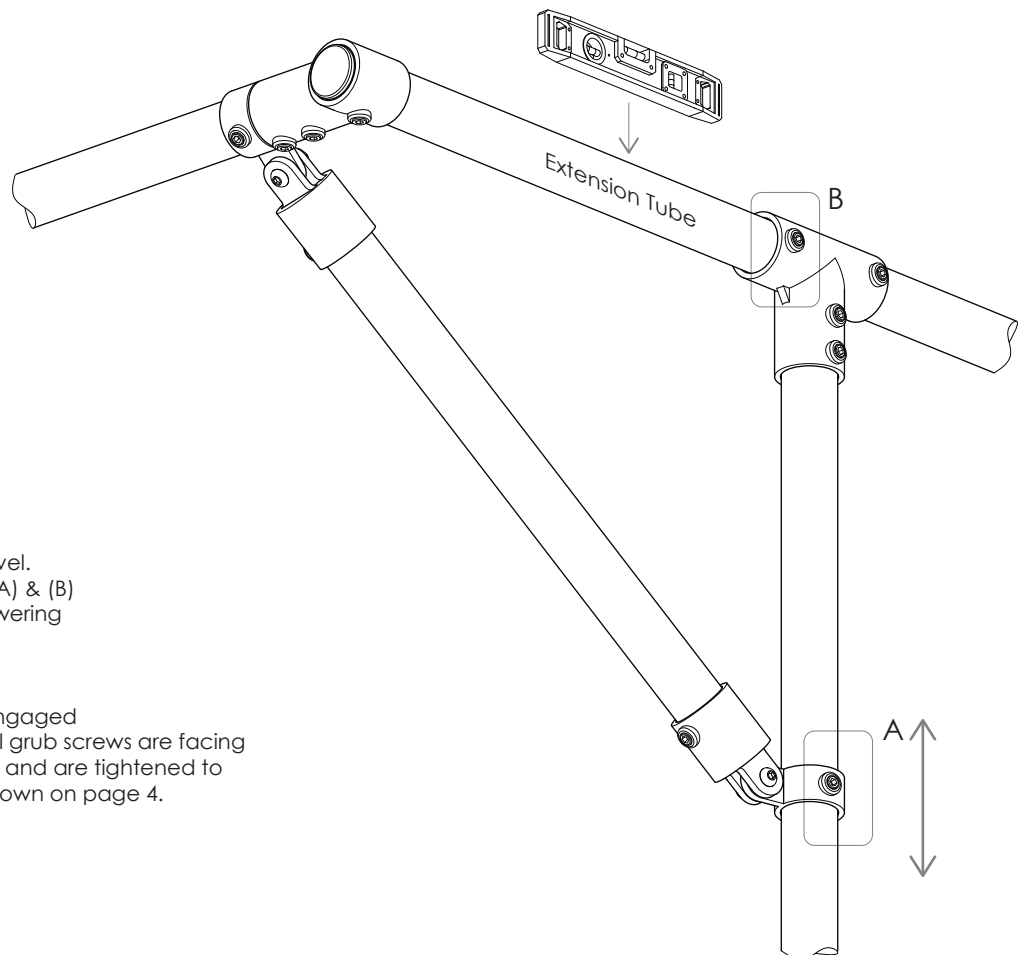

1. Ensure extension tube is level.
(If not loosen grub screw (A) & (B) and adjust by raising or lowering lower swivel brace tube.)
2. Ensure all tubes are fully engaged into the fittings and that all grub screws are facing downwards and outwards and are tightened to the correct standard as shown on page 4.

12 ATTACH ANY ACCESSORIES (IF APPLICABLE).

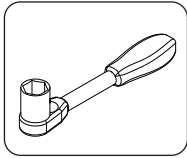

Attach any new accessories in desired position (if applicable) and tighten swing hook bolts with ratchet. Refer to individual accessory assembly instructions for details.

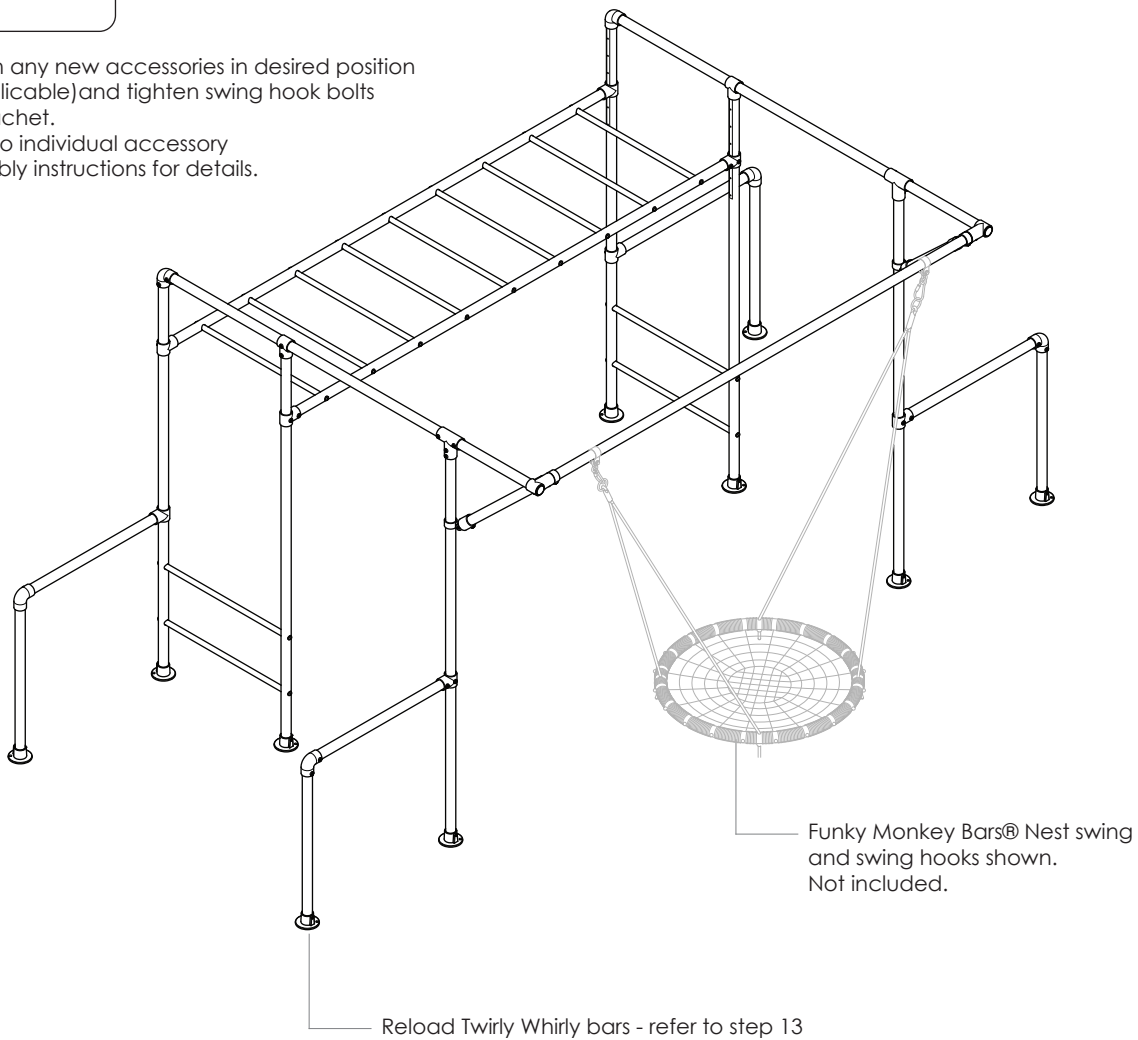

13 RELOAD TWIRLY WHIRLY BARS.

To reduce movement in your frame load your twirly whirly bars as per original frame assembly instructions or refer to website at www.funkymonkeybars.com/pages/videos

14 CHECK ALL GRUB SCREWS, NUTS AND BOLTS ARE FULLY TIGHTENED AS SPECIFIED. FAILURE TO DO SO MAY RESULT IN SERIOUS INJURY.

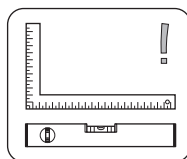
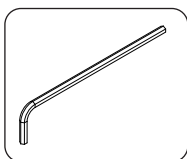

1. Ensure frame is square and level.
2. Firmly tighten all grub screws and rung bolts.

15 MAINTENANCE.

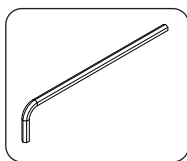
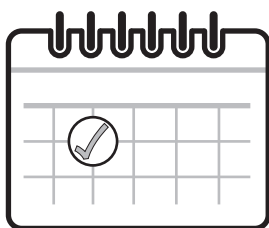

At the beginning of each heavy play session (especially a party) and twice a month during play season ensure;

1. Tighten all hardware - grub screws, nuts and bolts.
2. Pegs are in place and fully secure.
3. Lubricate all metallic moving parts (trolley and swing hooks.)
4. Ensure your frame is level and square.

FAILURE TO DO SO COULD RESULT IN SERIOUS INJURY OR DEATH.

**FOR MORE INFORMATION AND ASSEMBLY TIPS
PLEASE REFER TO OUR WEBSITE VIDEO INSTRUCTION SECTION AT
[HTTP://WWW.FUNKYMONKEYBARS.COM/PAGES/VIDEOS](http://www.funkymonkeybars.com/pages/videos)**

16 HAVE FUN



NOTES.



ABN 72 164 496 520



1300 912 198



info@funkymonkeybars.com



www.funkymonkeybars.com



9 Cutting Way,
Yangebup WA 6164



WE ARE SOCIAL MONKEYS



Australian Government
IP Australia

All Funky Monkey Bars® designs are registered and protected under IP Australian certification.