

## How your Rainwater Terrace®

### works

When it rains the Rainwater Diverter (1) collects water from the downpipe and starts to fill the Top Planter Tray (2), watering plants attached to it. When full it overflows into the top container (3). The level of water collected is visible in the Drain-tube (4). Once the container is full water overflows down the central tube (5) and onto the next Planter Tray (6) that supports and waters the side Planters (7). When this Planter Tray is full it overflows into the bottom container (8) and when that is full any excess is collected by the plinth (9) and returned back to the drain through the Outlet Tube(10).

Every time it rains sufficiently, water flows through the whole system replacing old water with new so minimising stagnant water.

Water can be drained from each container independently through its own Drain-tube. These each have a built-in tap that allows very rapid filling of watering cans or buckets.

The top and side planters are provided with special Capillary mats that draw up water from the planter trays and feed your plants from the bottom.

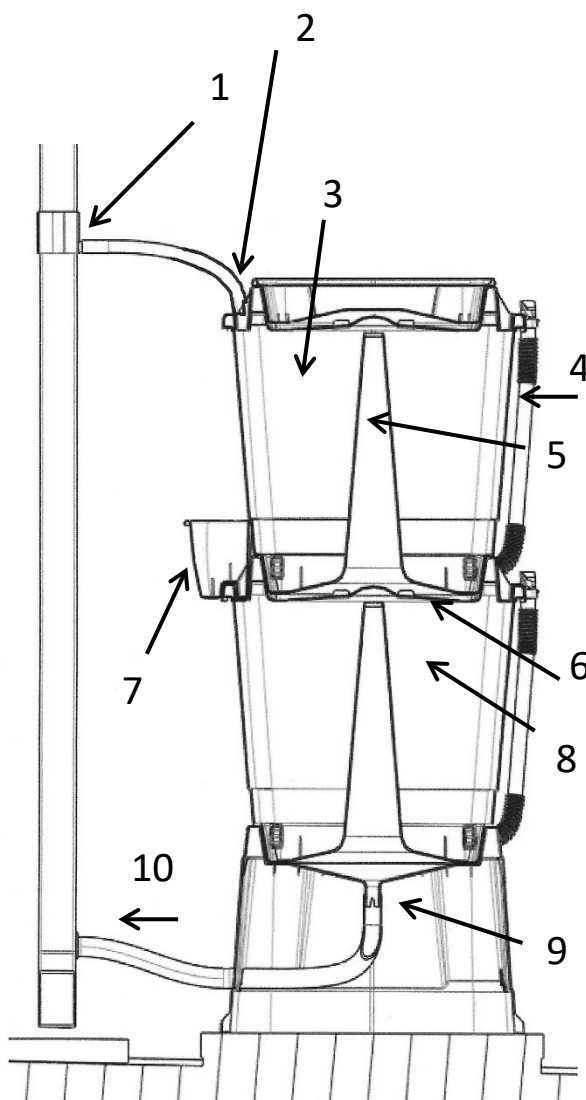

**The only tools you will need are for fixing the wall bracket to your wall and fitting the Diverter kit and drain outlet tube. See instructions later.**

**There is also a YouTube video you can watch :-  
<https://www.youtube.com/watch?v=JVpGD2SljaY>**

**IMPORTANT NOTE: NEVER BUILD A RAINWATER TERRACE®  
MORE THAN 3 CONTAINERS HIGH**

## Location And Preparation Of Site

Your Rainwater Terrace® should be positioned close to a downpipe from your roof gutter so that excess water can be fed back into the drain easily. It can be positioned either side of the downpipe. Your Rainwater Diverter should be fitted last so that the correct height of installation is achieved.

**When full your Rainwater Terrace® is very heavy so it is very important that it stands on a firm, flat, level surface that can withstand at least 160 kg. Check your intended site with a spirit level in both directions. (Most paving has a slight slope to encourage surface water to run away from your house).**

**The plinth should contact the ground all round its base so cobbles and uneven paving are not suitable. Never install directly onto soil or any surface that will sink under pressure.**

If in doubt we recommend installing a concrete base or a 60x60cm paving slab so that it can be set level. Any cement used to fix and level it should be allowed to set completely before installing your Rainwater Terrace®.

**If 2 or more Terraces are to be connected together they must all be on the same level. If your site does not permit this they must each be connected to the downpipe independently.**

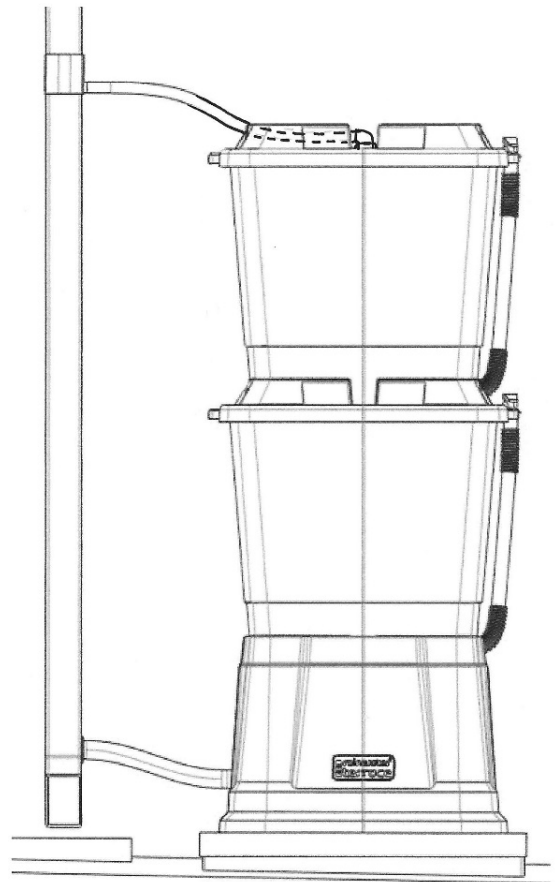

## Assembly

1. Lay the Plinth on its back as shown, assemble the Outlet Tube (12) to the spigot on the underside of the Plinth as far as it will go and feed the other end through the hole nearest to your Downpipe. (You can soften the end of the pipe in warm water to make it easier to fit)

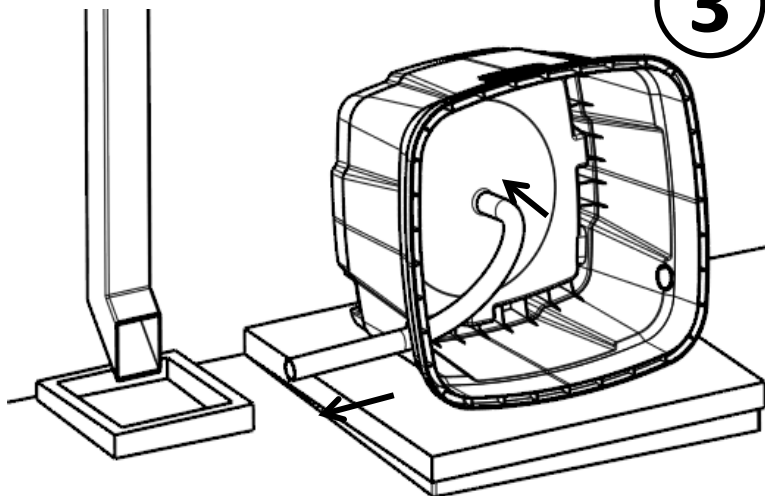

2. Position the Plinth on the flat base about 2cm from the wall. The outlet tube can be cut to length later when you are ready to connect to the Drain.

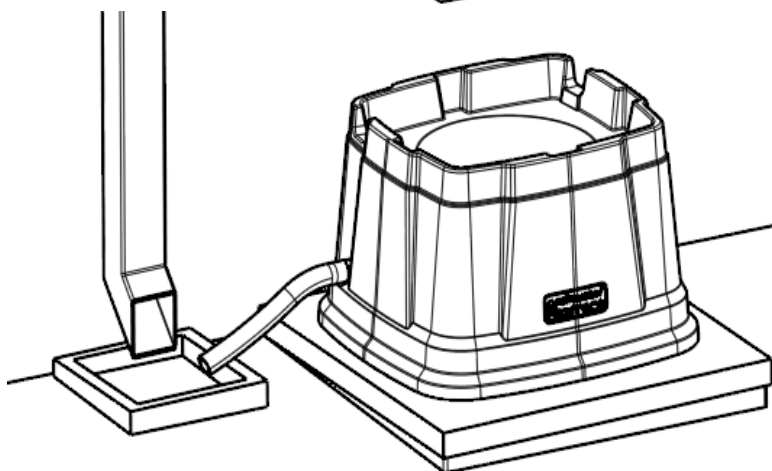

3. Place the first container on the Plinth (it will only fit one way). Choose which side you want your Drain-tubes and, making sure the tap is closed, hook one onto its holster at the top of the container. Insert the other end into the hole in the container and fit the Retaining Ring on the inside as shown.

Turning the Retainer ring in a clockwise direction will pull the sealing ring into place. Make sure you stop the Drain-tube rotating from the outside.

4. Fit a Bung in the other hole using another Retaining ring as described above.

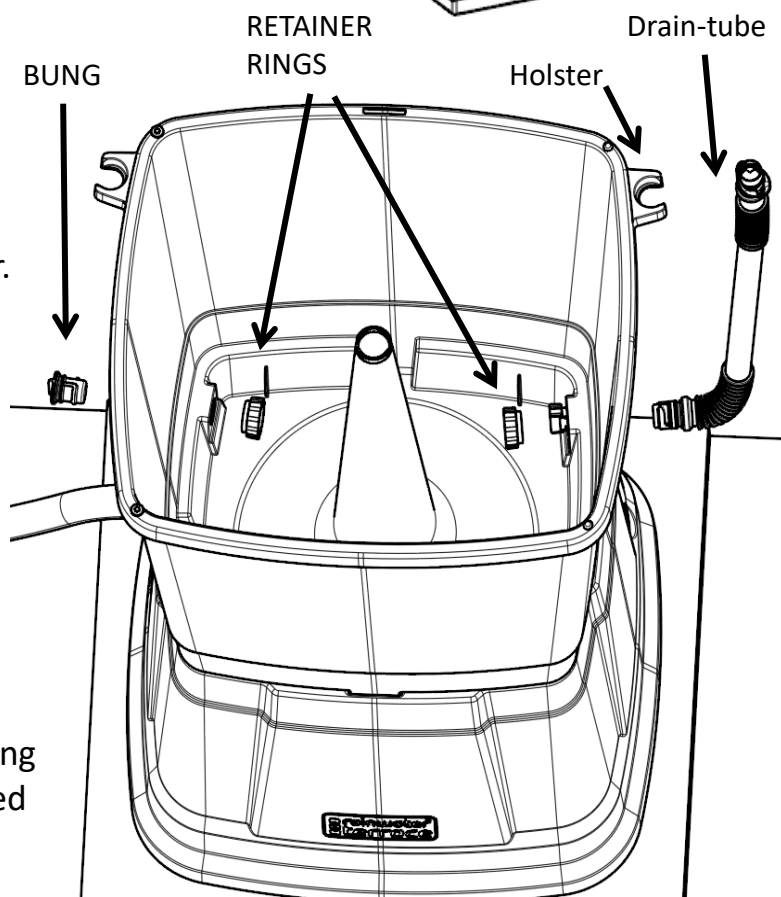

5. Assemble the first Planter Tray (the one without the inlet panel) – it will only fit one way round.

Place the second container on top making sure the wall bracket fits through the slot at the back. If necessary reposition the plinth so that all the modules fit together properly at the same time.

Fit the second Drain-tube and a second Bung as before using the Retainer Rings (they can be either way round)

6. At this point you can check that the Bungs and tubes are properly sealed by removing the top module and pouring a bucket of water into the bottom container. Repeat for the other container.

Finally fit the top planter tray .

BUNG

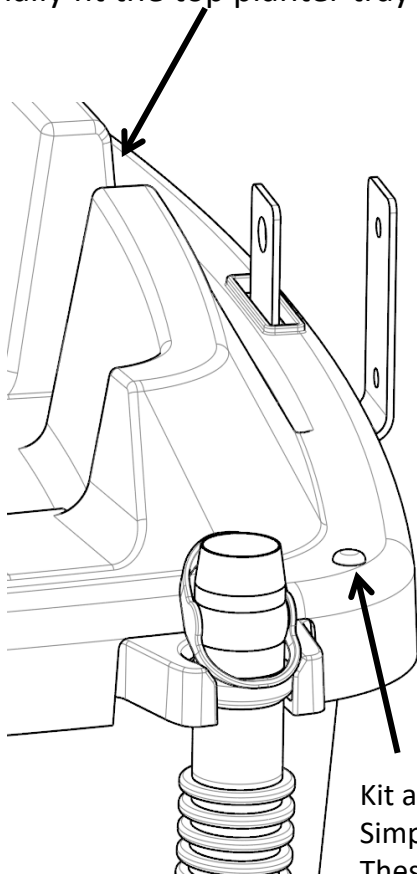
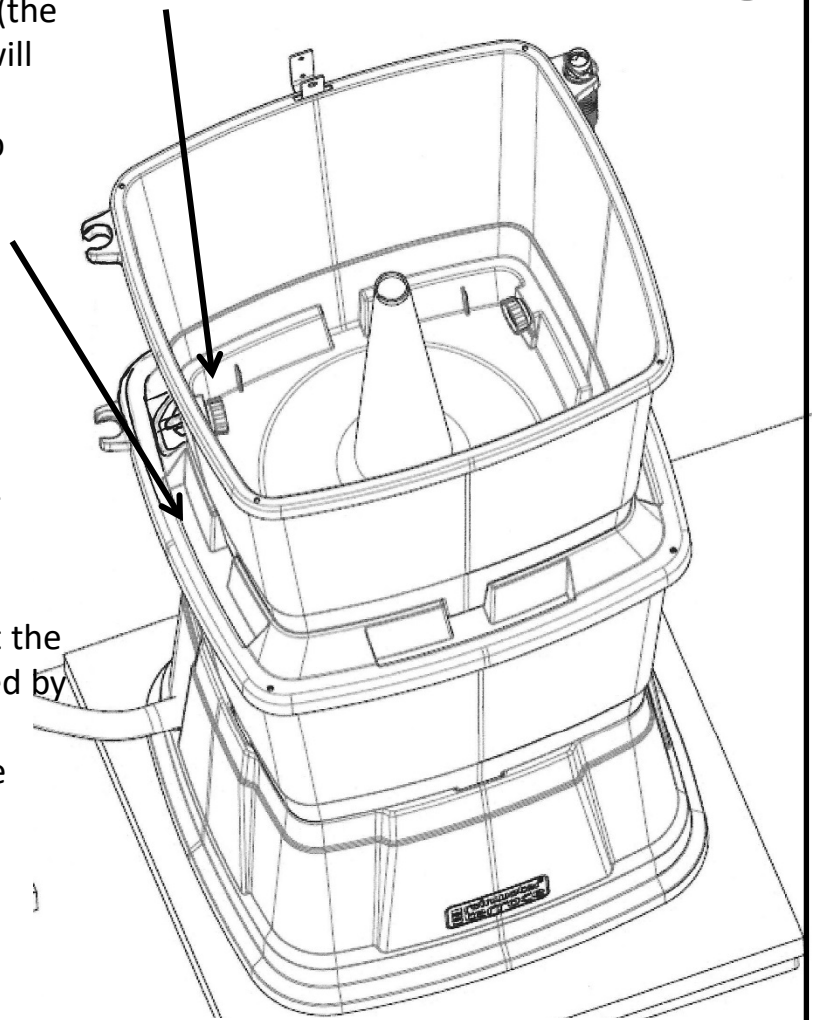

Your Rainwater Terrace® is very stable but we do have a steel Wall bracket (to buy separately) for added security. Mark a vertical line on your wall at the centre point of your base and mark out the 2 screw positions as shown. Drill the 6mm holes for the wall plugs and screw the bracket securely in place.

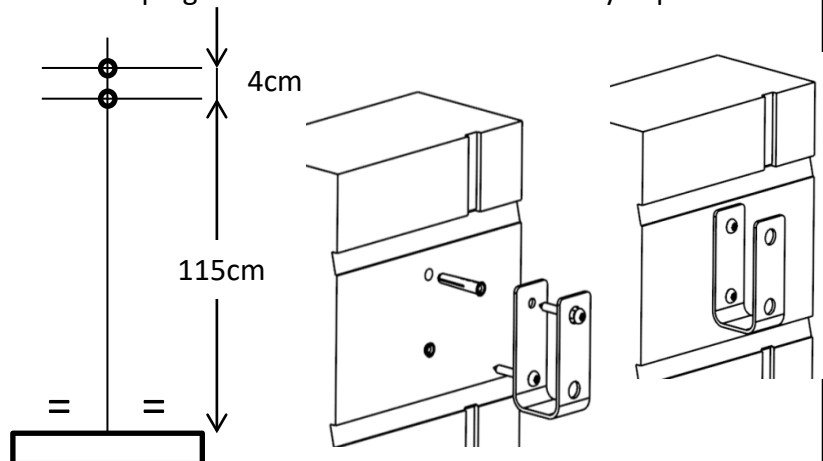

Kit also includes plastic fixings to make the lid even more secure. Simply insert from the top and push in the peg. These can be removed later by pushing the peg up from underneath

## Connection To A Rainwater Diverter

For your Rainwater Terrace® to work the outlet from your rainwater diverter must be higher than the top rim of your top container otherwise water cannot overflow down the central tube (5) that feeds the lower containers.

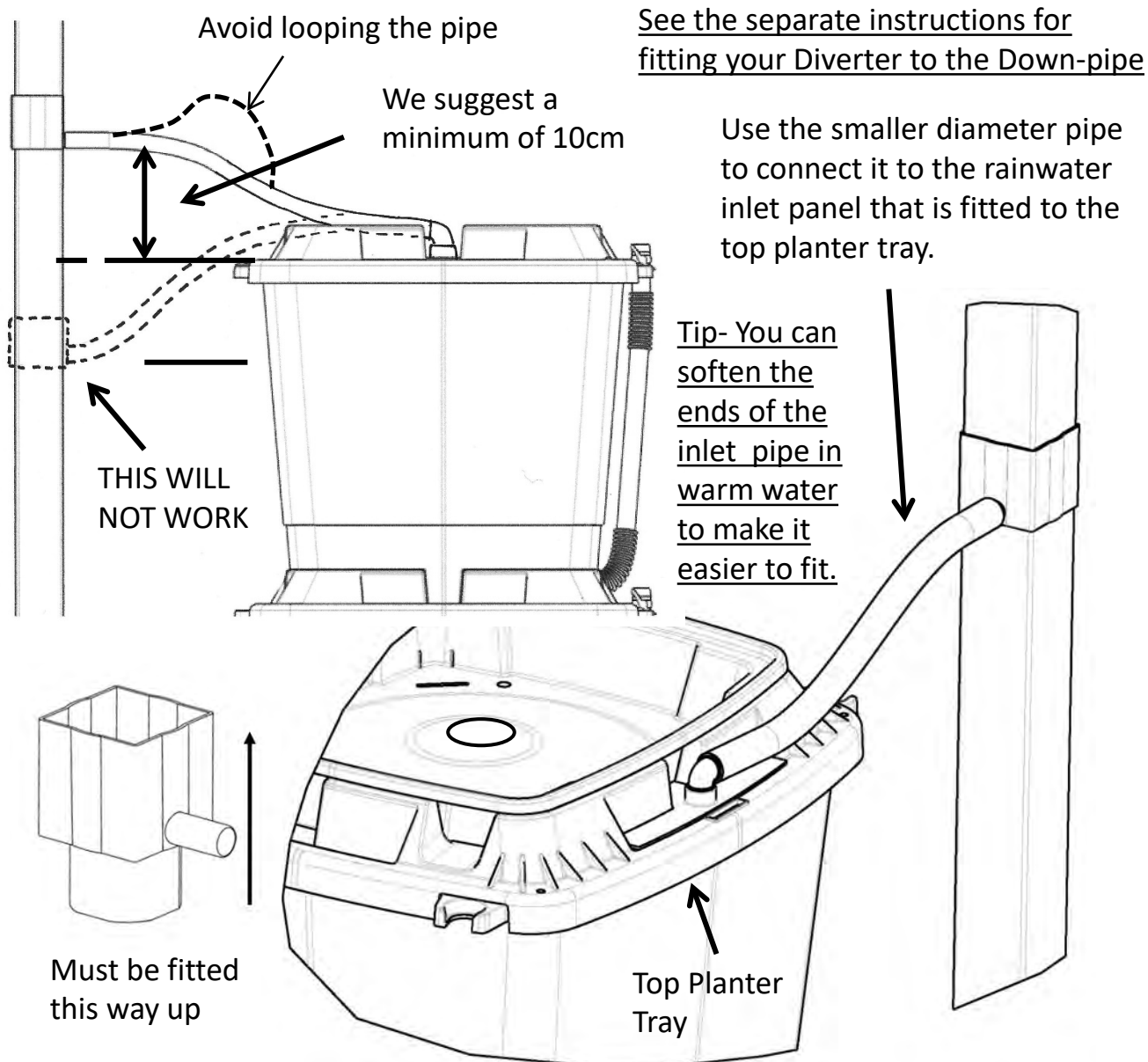

There are many different Diverter kits you can use, which will depend on your particular drainage requirements.

1. The Diverter we supply is suitable for standard 65mm square or 68mm round plastic down-pipes and will divert a large proportion of the rain falling through your Downpipe into your Rainwater Terrace® including any debris from your gutter. This will collect mainly in the top Planter Tray which is easy to clean out.

2. If you have problems with bunged up soak-aways there are Diverters such as the "Gutter Mate" that collect the debris in a filter that must be emptied regularly. This is also useful if you have larger Down-pipes.

Follow the installation instructions that come with the Diverter kit with regard to cutting into your Downpipe but always bear in mind the instructions above.

## Connecting The Outlet Pipe To The Drain

### There are 3 basic types of rainwater drain-away

1. Into a grate linked to a drain or soak-away. Either fit the rubber grommet supplied as shown below or fit a plastic drain cover and fit the outlet tube into that

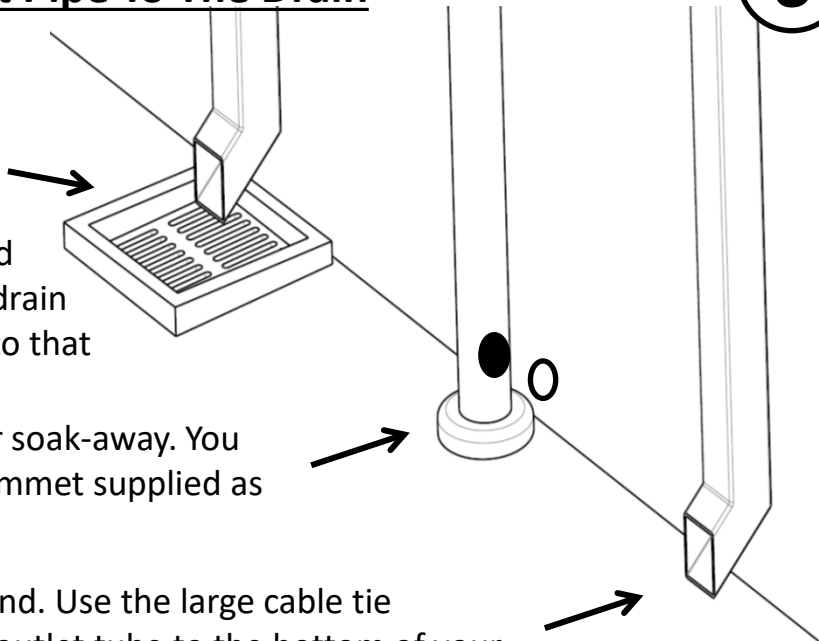

2. Directly into a drain or soak-away. You must use the rubber grommet supplied as shown below.

3. Directly onto your land. Use the large cable tie supplied to attach the outlet tube to the bottom of your down-pipe

### To fit directly into your down-pipe

Drill a hole 35mm diameter with a hole saw (not supplied). Position as low as possible on your down-pipe.

Then fit the rubber grommet supplied.

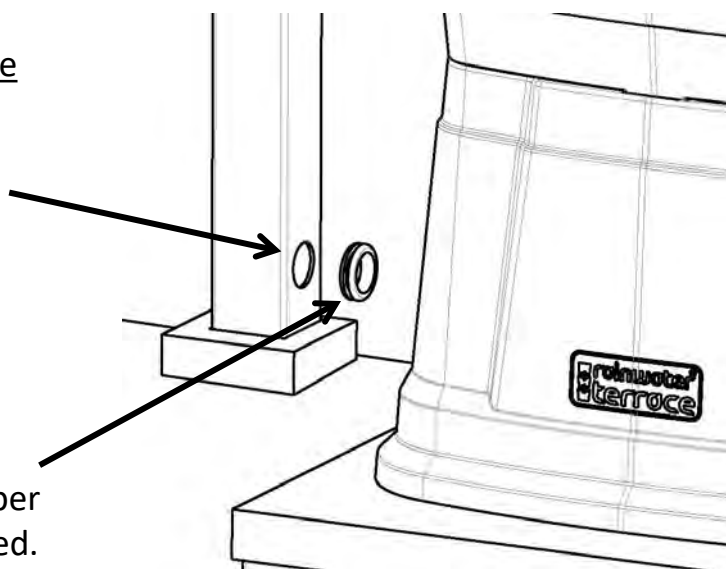

Finally insert the free end of your overflow tube. You can chop this to length so that about 3cm of pipe is inside the down-pipe.

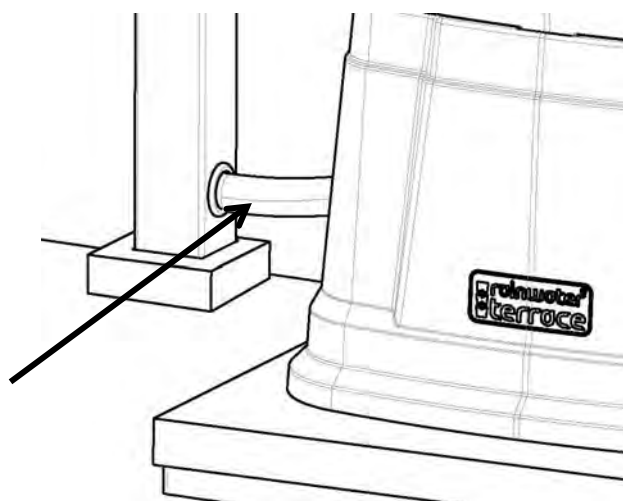

## The Planters

Now for the creative bit! Your Rainwater Terrace® is supplied with side planters and a top planter and pre-cut capillary mats for each that draw up water from the planter trays.

**The Side Planters** use the large mats. Fold back the flaps either side of the central tongue and feed it through the slot in the bottom of your planter then flatten out the mat as shown. Add some gravel to hold it in place and then fill up with compost that suits your plants. You will often benefit from the addition of horticultural grit or sand to improve drainage.

Plant up and fit your creation into the mounting slots in the planter trays on your Rainwater Terrace® making sure the tongue dips into the water.

If the planter tray is still dry you can top it up through any of the vacant mounting slots. The planter trays are replenished only when it rains so check the level of water regularly.

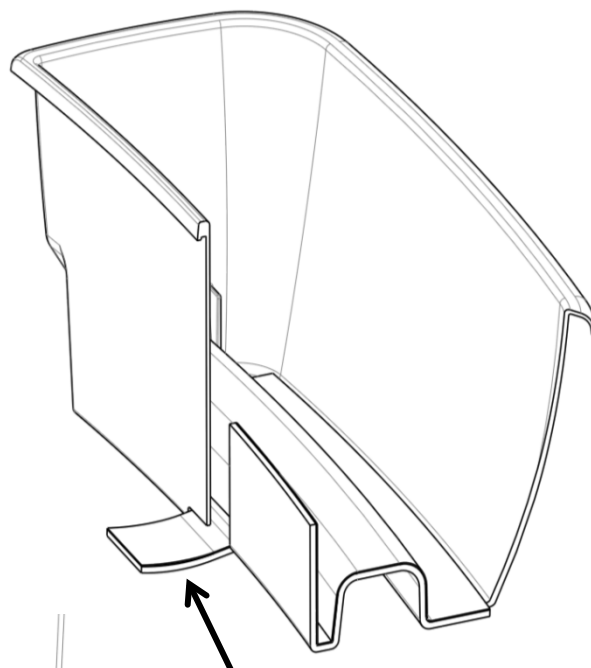

**TONGUE**

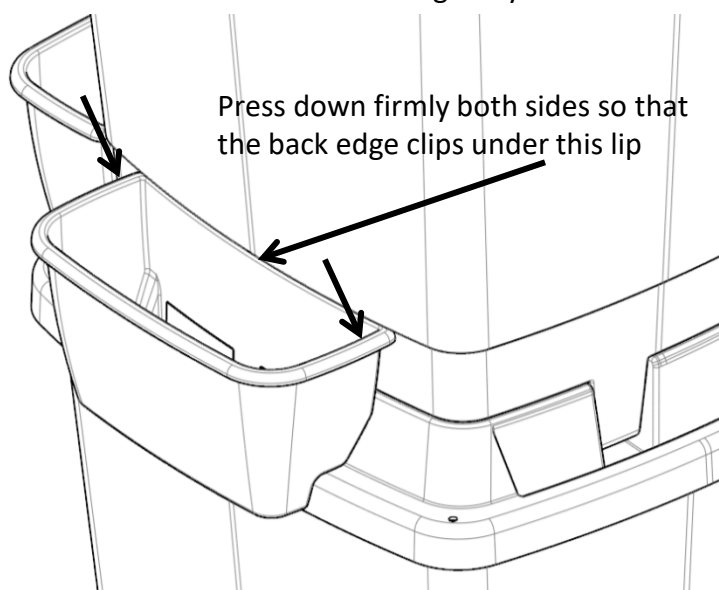

Press down firmly both sides so that the back edge clips under this lip

You can use your planters in the greenhouse and pop them on when you are ready.

**The Top Planter** uses the 4 small mats that are fed through the slots from the top.

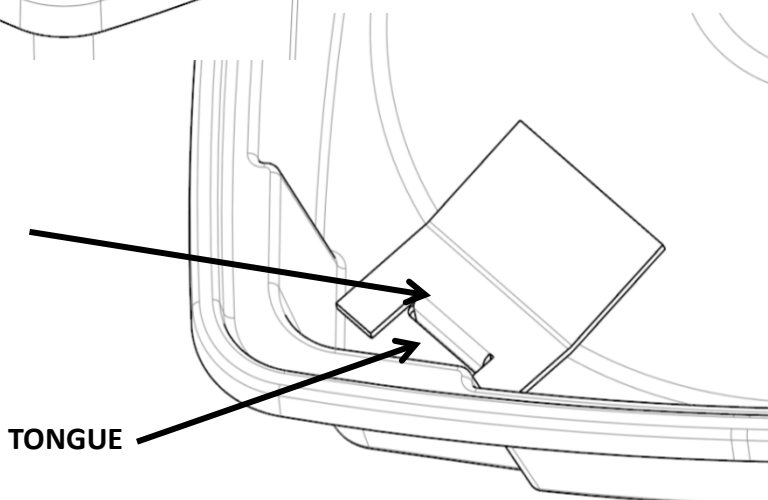

**TONGUE**

## Connecting 2 Or More Terraces Together

**Both towers must be at the same level to operate properly otherwise all the planter trays may not be replenished when it rains.**

To join 2 towers together you will need the connector kit that comprises 2 connector tubes and 1 blanking cap.

Fit the connector tubes using the Retainer rings from the Rainwater Terrace® kits. You only need one drain-tube for each level.

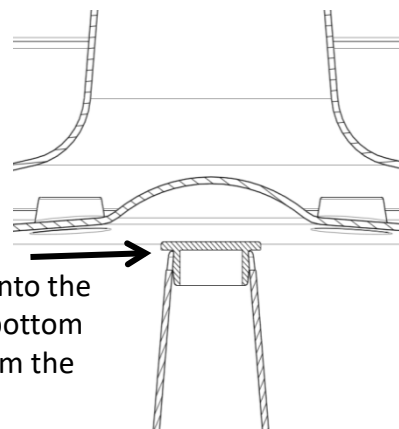
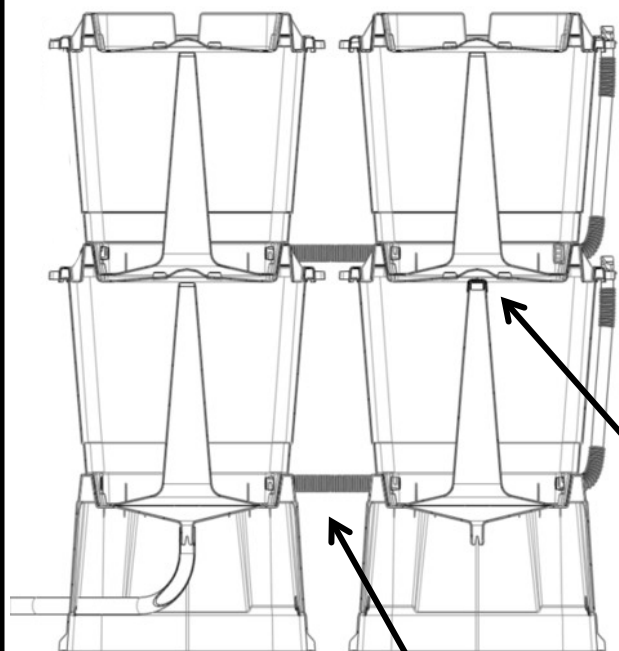

Fit the blanking cap onto the central cone on the bottom container furthest from the drain as shown.

Connector Tubes x2

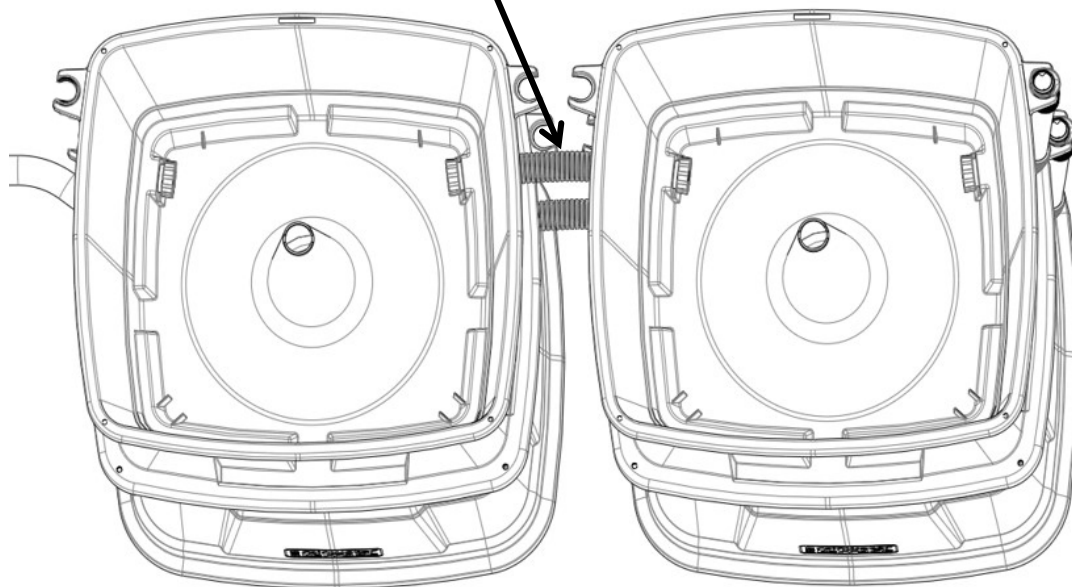

**rainwater  
terrace**

A Design 4 Plastics Ltd Product  
402, Birch Park, Thorp Arch Estate,  
Wetherby, West Yorkshire, LS23 7FG, UK  
Tel: 01937 845176  
[www.rainwater-terrace.com](http://www.rainwater-terrace.com)  
Email: [rainwater-terrace@design4plastics.com](mailto:rainwater-terrace@design4plastics.com)