

**Attention!** Before first use, please read the operation and safety instructions carefully!

# **sIMPLEk – assembly set**

1.0 General remarks and safety instructions

2.0 Assembly and installation

2.1 Assembly of parts

2.2 Installation

3.0 Handling

3.1 1:1-Mode

3.2 Tuning-mode

3.2.1 Reset of the maximum speed

3.3 Calibration

---

***sIMPLEk***  
***E-Bike tuning***

## 1.0 General remarks and safety instructions

### Note for StVo or use on public roads

The completed assembly set, obstructed in a compatible E-Bike, causes the suspension of the factory-integrated speed regarding the support of the motor.

Thus, the establishment of the completed assembly set, within the scope of the StVO or on public roads, is forbidden and not accepted.

The use of the assembly set is only provided for closed-off public traffics as well as for private grounds and race courses.

The offered "SIMPLEk"-assembly set (here called as "SIMPLEk") will be delivered in individual parts and cannot be used in delivery conditions.

The assembly set is only allowed to be used by experts allowing for applicable regulations and standards regarding the equipment.

The SIMPLEk-Stick is compatible with the following E-Bike engines:

- Bosch (Classic, Active (Plus), Performance (CX), Cargo)
- Yamaha (PW, PW-SE, PW-X(2), PW-ST, PW-TE, PW-CE, GIANT SyncDrive)
- Impulse (2.0, EVO-RS)
- Brose (Drive C/T(F)/S, Specialized 1.1(SL)/1.2(S/E)/1.3/2.1)
- Shimano (Steps E5000, E6000, E6100, E7000 E8000, EP8) with and without Di2
- Bafang (Max Drive)

Please note that the technical characteristics of your e-bike may not be designed for the use of tuning measures without further technical adjustments. The use leads to the warranty loss of the e-bike. If the e-bike concerned has an operating license, it will be extinguished.

Please put on a suitable helmet at all times!

The usage of the assembly set leads to the loss of warranty concerning the vehicle.

Regarding the installation of the E-Bike, please make sure not to damage any cables while-installing the protection cover of the motor. Thus, you can prevent electrical shorts which could lead to major cable bruises or fires.

Liabilities for any damages will not be assumed (directly or indirectly) that may arise by activating the completed assembly set.

Use at your own risk!

## 2.0 Assembling and installation

The SIMPLEk-assembly consists of 5 components only:

- circuit board (picture 01)
- microcontroller (picture 02)
- capacitor (picture 03)
- diode (picture 04)
- connectors (picture 05, picture 06)

The assembly is simply designed.

picture 01 - circuit board

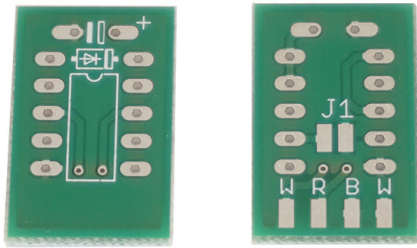

picture 02 - microcontroller

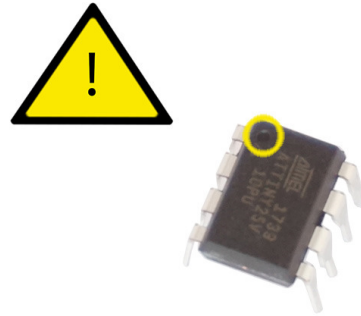

picture 03 - capacitor

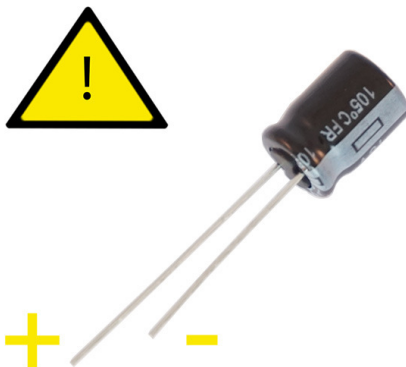

picture 04 - diode

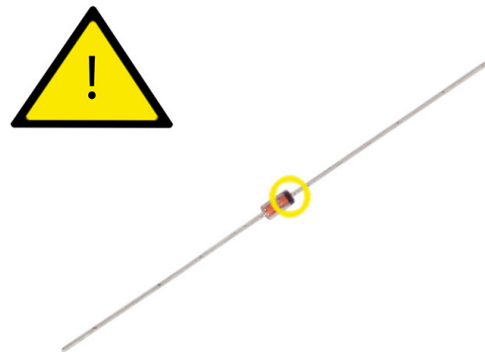

picture 05 – connector engine side



picture 06 – connector sensor side



## 2.1 Assembly

Concerning the equipping you have to pay attention to the polarity of the capacitor and diode (picture 03, 04). The alignment of the microcontroller must also be considered (there is a shortly rounded immersion on the surface of the microcontroller and the notch in the wildcard symbol on the planting have to be located on one side - picture 02). Having a false alignment, the SIMPLEk is not working. The E Bike might not be damaged.

There are W, R, B, W labelled solder pads which have to be connected with the cables of the plugs as follows:

**W:** connection white cable (you don't have to pay attention to the polarity)

**R:** connection red cable

**B:** connection black cable

In case of bridged connection „J1“, the SIMPLEk directly starts in tuning-modus. The 1:1 modus being dropped. Further information can be found in section „3.1 1:1-mode“.

There is a heat-shrink tubing provided with sealant which serves as waterproof shell (picture 13). This heat-shrink tubing will be shrunk ideally with a heat gun, alternatively with a lighter (picture 14). Because of the heat, the sealant will be activated. Under hot conditions please press on carefully the beginning and the end of the heat-shrink tubing in order to ensure the seal completely.

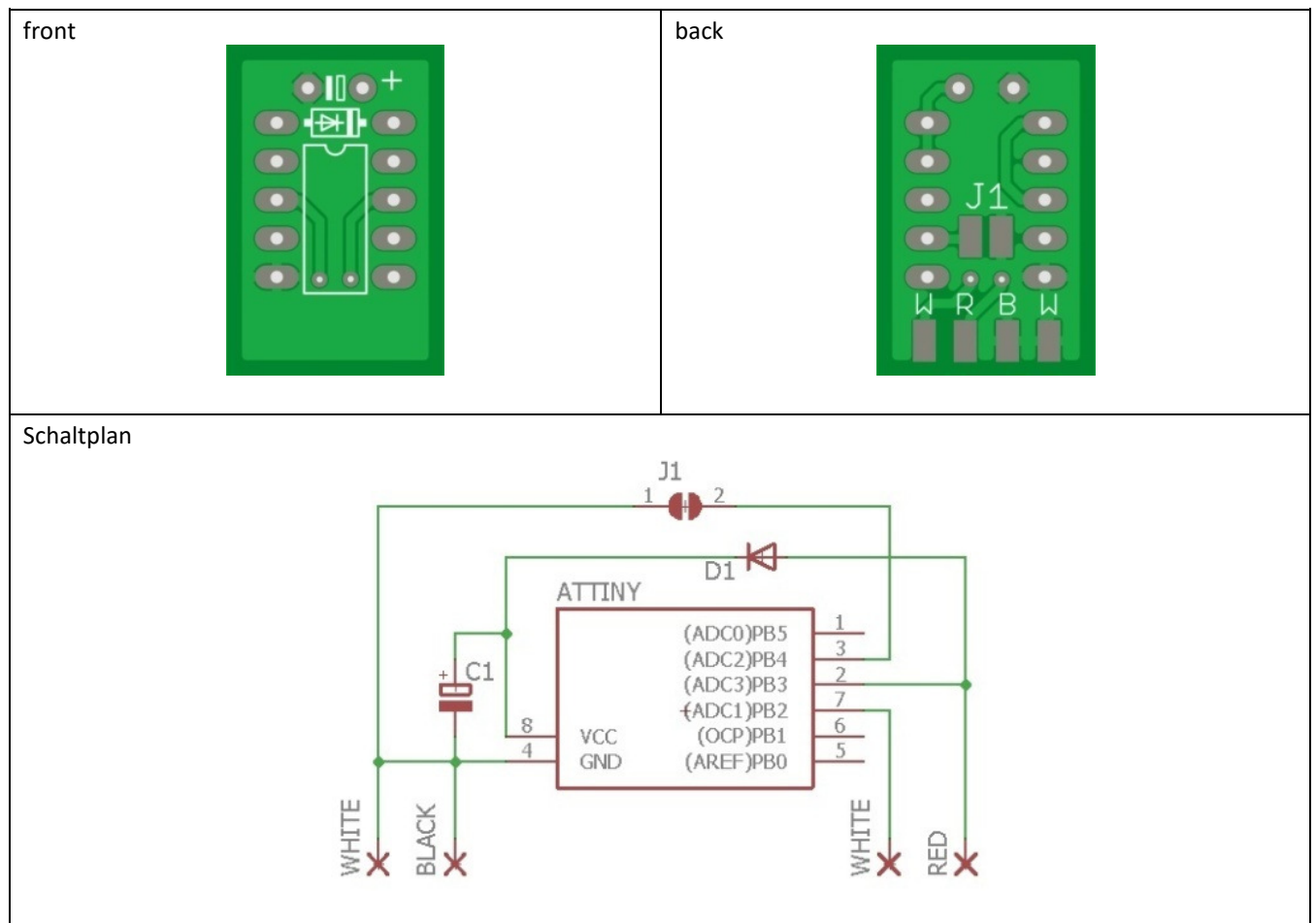

picture 06 - condensator



picture 07 – soldered condensator

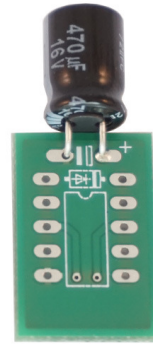

picture 08 - diode



picture 09 – soldered diode

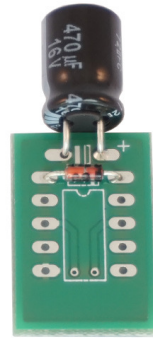

picture 10 – completely fitted - front

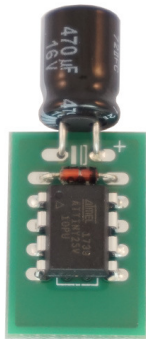

picture 11 completely fitted- back

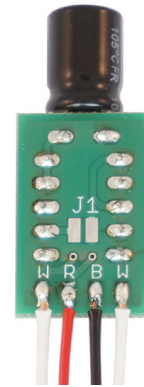

picture 12 – heat-shrink tubing



picture 13 - shrank heat-shrink tubing



## 2.2 Installation

Before you start with the installation switch off the e-bike in deep-sleep mode (hold down the power button on the control unit or on the battery for at least 3 seconds) and remove the battery of your E-bikes!

The SIMPLEk is upstreamed in front of the original sensor. For this purpose the motor cover has to be removed. Depending on the engine version you need additional tools.

## Installation based on an engine version Brose:

Required tools:

- Torx 20 wrench
- 8 mm allen key
- crank puller (if you can't remove the crank per hand)
- optional: flat nose pliers

Unscrew the 8 mm allen key (picture 14). Remove the crank. If you can't remove the crank by hand, take a crank puller. Remove the 5 Torx screws with a socket (picture 15). Now the engine cover can be removed. If necessary, pull the plug speed sensor with a flat nose pliers (picture 16).

Now connect the motor-side connector (red and black cables, Figure 17) of the SIMPLEk to the position of the previously disconnected speed sensor. Pay attention to the polarity of the connector. The polarity of the slot on the motor is shown in Figure 16. The polarity of the connector on the SIMPLEk is shown in Figure 17.

Then connect the speed sensor to the second connector of the SIMPLEk (2 white cables).

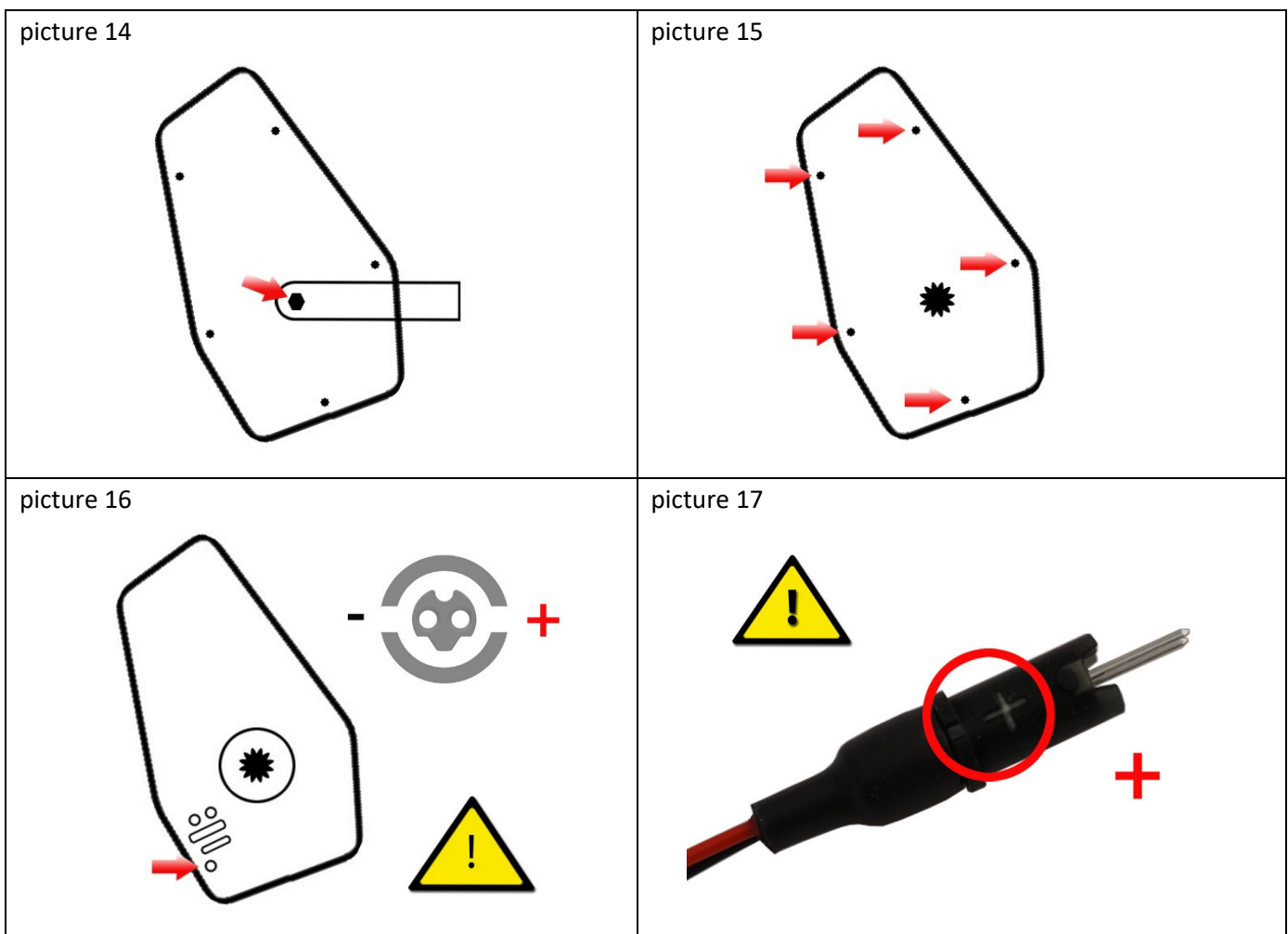

### 3.0 Handling

The SIMPLEk includes 3 operation modes:

[1] 1:1-mode

[2] tuning-mode

[3] calibration-mode

There is a change from one to another operation mode, if after the start, the E-Bike will be switched off into Deep-Sleep-Mode within of 15 seconds and restarted again. The period of 15 seconds starts as soon as the E-Bike is started.

**Attention! Deep-Sleep-Mode:** When changing the operating modes, it is necessary to put the e-bike in deep sleep mode when switching off. This is achieved by holding down the power button on the battery for at least 3 seconds. This also applies to the shutdown during calibration.

A calibration is only necessary once so that for every wheel circumference the real speed in tuning modus can be read.

In the 1:1 mode the SIMPLEk passes signals of the speed sensor one-to-one. Therefore the E-Bike acts like in an original condition.

The tuning-mode makes an unlimited support possible (theoretically up to  $100 \frac{km}{h}$  (mph)).

Table – change between the operation modes

[1]	→ E-Bike will be restarted within 15 seconds after start	[2]	→ E-Bike will be restarted within 15 seconds after start	[3]	→ Performance or cancellation of the calibration	[1]
		[2]	→ E-Bike stays on longer than 15 seconds and will be restarted	[1]		
[1]	→ E-Bike stays on longer than 15 seconds and will be restarted	[1]				



### 3.1 1:1-Mode

After the E-Bike will be running longer than 15 second in the tuning-mode or 1:1-mode and switched off into Deep-Sleep-Mode (see 3.0 handling), the E-Bike will always start in 1:1-mode. During this mode the E-Bike behaves as if it was not modified. In order to deactivate the 1:1-mode permanently and starting it directly, the connection „J1“ must be bridged (see 2.1 assembly).

### 3.2 Tuningmode

The tuning mode will be active when switching off the E-Bike into Deep-Sleep-Mode (see 3.0 handling) within 15 seconds after powering up in 1:1-mode. When switching on again, the tuning mode is activated. The speedometer displays  $10.0 \frac{km}{h}$  (mph). If you don't move the E-Bike for approx. one minute, the display returns to  $0.0 \frac{km}{h}$  (mph). The actually travelled speed remains readable during the tuning-mode. Up to  $20 \frac{km}{h}$  (mph), it is issued 1 to 1. Above  $20 \frac{km}{h}$  (mph) the speed will be displayed over the second number and decimal place. If the speedometer does not have a decimal place, the displayed speed is accordingly less accurate. Examples:

$$\begin{array}{lcl} 22.5 \frac{km}{h} \text{ (mph)} & \rightarrow & 25 \frac{km}{h} \text{ (mph)} \\ 23.8 \frac{km}{h} \text{ (mph)} & \rightarrow & 38 \frac{km}{h} \text{ (mph)} \\ 24.5 \frac{km}{h} \text{ (mph)} & \rightarrow & 45 \frac{km}{h} \text{ (mph)} \end{array}$$

In order to balance the difference between the actual forward speed and the route displayed on the speedometer, the maximally driven speed will be displayed on the speedometer after one minute whilst standstill until the route will be caught up. As soon as the difference will be balanced, the speedometer displays  $0.0 \frac{km}{h}$  (mph) and the E-Bike switches off itself independently. If the E-Bike will be switched off in advance, SIMPLEk stores the difference with an accuracy of 200m and catches up the route later on.

Thus the maximal speed as well as the actually travelled route/total distance will be reproduced correctly.

#### 3.2.1 Resetting of the maximal speed

The maximal speed displayed to compensate for the difference in the distance traveled, will be resetted by re-performing the calibration completely or break off started calibration by moving the E-Bike. After break off the SIMPLEk returns to the 1:1-mode.

Now the maximal speed is resetted.

### 3.3 Calibration

The calibration has to be carried out once and has to be shifted during standstill and with an inserted rechargeable battery pack.

On first start, the calibration will be automatically called up. It consists of two sections. At first it will be grossly calibrated, then more precise. In the first section of the calibration, an increased speed will be displayed on the speedometer. Switch off the E-Bike into Deep-Sleep-Mode (see 3.0 handling) as closely as possible at  $10.0 \frac{km}{h}$  (mph). If you switch on again, precised calibration will be start. You can see the speed on the speedometer which comes closer in small steps to  $10.0 \frac{km}{h}$  (mph). As soon as the  $10.0 \frac{km}{h}$  will be displayed for the first time, again switch off the E-Bike into Deep-Sleep-Mode (see 3.0 handling). Thus, the calibration is completed.

After a successful calibration the SIMPLEk should exactly display  $10.0 \frac{km}{h}$  (mph) in the tuning-mode.

**Start the calibration mode manually:** In order to start the calibration mode manually, the e-bike has to be switched off in deep-sleep mode within about 15 seconds in the tuning mode and then restarted.

**Interrupt calibration:** If you move the E-Bike during the calibration mode, the calibration will interrupt and the SIMPLEk will goes back into the 1:1-mode. In this case a calibration does not take place.