

ABIDE BY ROHS

Plum shaft

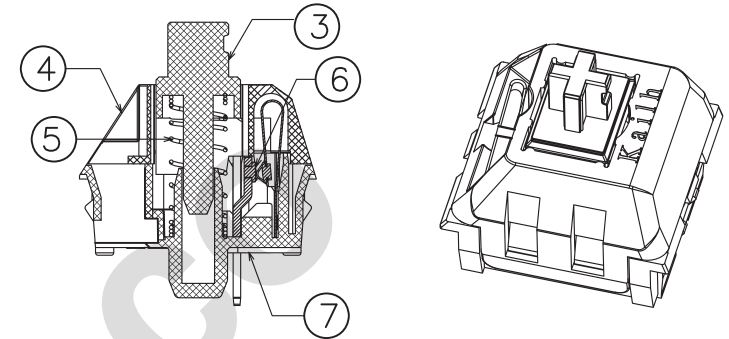
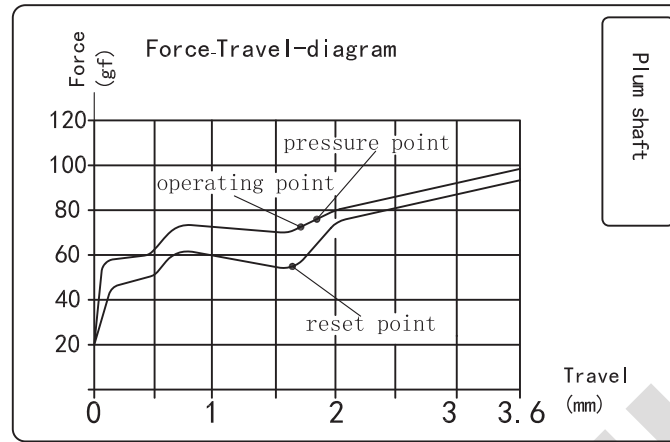
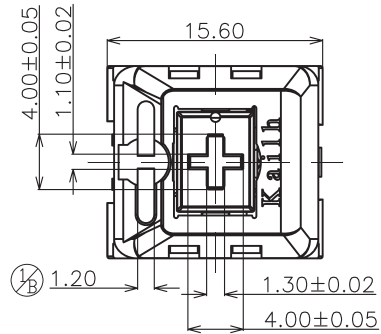

Specification :

- 1. Rating : 12V AC/DC max. 2V DC min. 10mA AC/DC max. 10 μA DC min.
- 2. Contact Resistance : 100mΩ Max
- 3. Insulation Resistance : 100MΩ Min (DC500V)
- 4. Withstand Voltage : AC100V (50-60Hz) for 1 minute
- 5. Bounce Time : ≤5msec (at 16 in/sec. actuation speed)
- 6. Operation Force : 70±15gf
- 7. Tactile Force : 70±15gf
- 8. Pre travel : 1.7mm±0.6mm
- 9. Total travel : 3.6±0.6mm
- 10. Operating Life : 70,000,000 Cycles (min).

<Feel is allowed to have difference before and after life test>

SWITCH FUNCTION

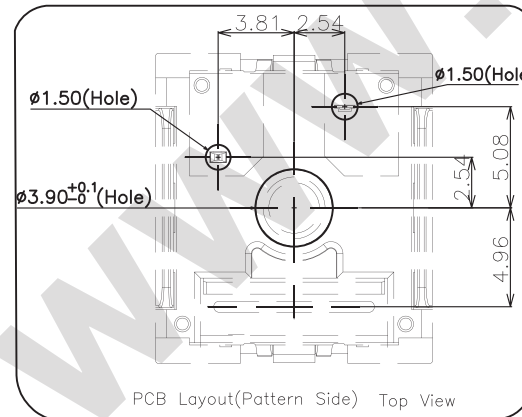
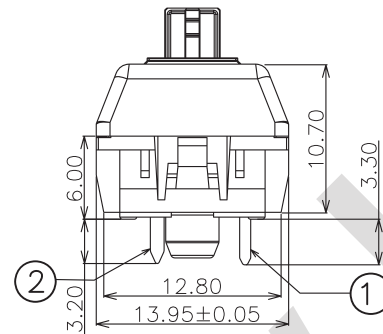
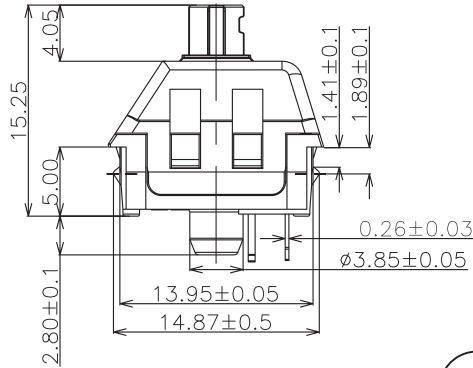
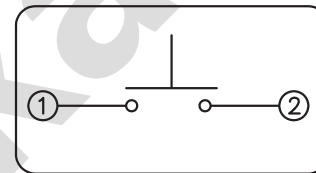

The Tilt Angle Of The Switch

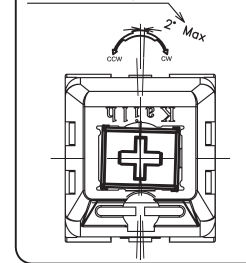

⑦	Base	1	PA66	White		
⑥	contact	2	Composite gold			
⑤	Spring	1	Stainless Steel			
④	Cover	1	PC	Nature		
③	Keystroke	1	POM	Plum		
②	static plate	1	Brass	sn-plating		
①	movable plate	1	Copper Alloy			
ITEM	PART NAME	TER'NO	QTY.	MATERIAL	FINISHING	REMARK

APPROVALS		DATE	Kailh KAIHUA ELECTRONICS CO., LTD			
DRAWN	Y.J.P	2017.09.15				
CHECKED			TITLE:	PG1511 Keystroke Switch(Plum shaft)		
APPROVALS			PART NO.	CPG151101D232		
TOLERANCES ARE	30<L	±0.30	ANGLE	UNIT:	mm	
	10<L	±0.20		SCALE:	1:1	
	5<L	±0.15		DRAWING NO.	KHA-PG1511-200EN	
	L	±0.10		±2'	PROJ:	
			DRAWING NO.	KHA-PG1511-200EN	SHEET 1 OF 1	

ECN NO.	REV.	DATE.	DESCRIPTION.	CHANGE.	CHECK.	APPRO.
			Change cover size from 0.8*8.6mm to 1.2*8.9mm. Static plate coating add tin over Ni.			
			NEW			

Kailh

KAIHUA ELECTRONICS

Document Number:

KH-PS1710-06

Product Specification

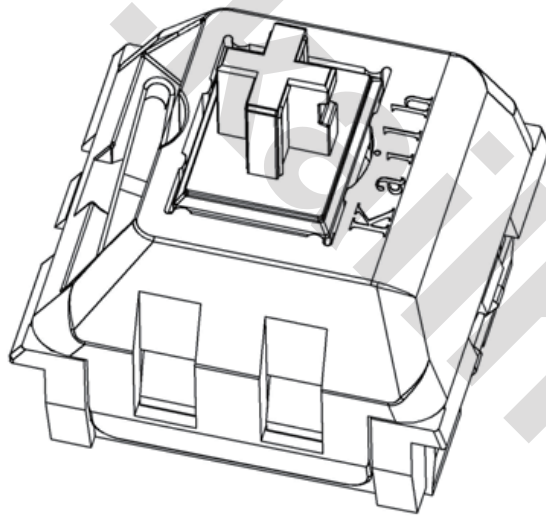

P/N:

CPG151101D232

Title :

PG1511 Keyboard Switch

P/N: CPG151101D232	DOC. No.: KH-PS1710-06	Rev.: A	Page: 2/11
------------------------------	----------------------------------	-------------------	----------------------

Content

1. Scope	3
2. Product Application	3
3. Technology Parameters	3
4. Ratings	3
5. Profile Dimensions	3
6. Electrical Performance	4
7. Mechanical Performance	5~6
8. Environmental Performance	7~9
9. Recommended PCB Layout	10
10. Loading Parameter Specification	11
11. Precaution	11

P/N: CPG151101D232	DOC. No.: KH-PS1710-06	Rev.: A	Page: 3/11
------------------------------	----------------------------------	-------------------	----------------------

1. Scope:

This Product Specification covers the requirement of Mechanical Keyboard switch on product performance, test methods and quality assurance provisions.

2. Product Application:

Mainly applied on computer keyboards, cash registers, industrial equipment and Man-Machine interface.

3. Technology Parameters:

Ambient Humidity: 45 ~ 85% RH

Operating Temperature Range: -10°C ~ +70°C

Storage Temperature Range: -20°C ~ +70°C

Suggested storage period: about 6 months

Require the tin part on the switch terminals should keep good after storage guarantee date

Normal Condition:

Ambient temperature: 20±2°C

Relative humidity: 65%±5%RH

Air pressure: 86~101KPa

4. Ratings

Rating: 12V AC/DC max. 2V DC min

10mA AC/DC max. 10μA DC min

Insulation Resistance: ≥100MΩ/DC 500V

Withstand Voltage: 100 AC 1 Minute

Mechanical Life: 70,000,000 Cycles

5. Profile Dimensions

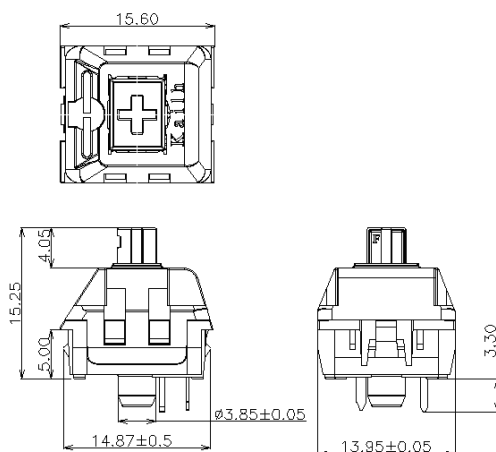

6. Electrical Performance

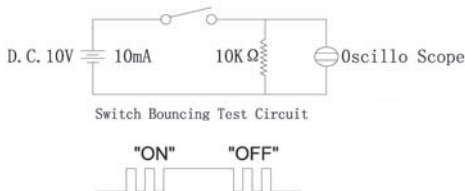
Item	Description	Test Condition	Requirement
6.1	Contact Resistance	<p>Static load: (Operation force)x2, which is applied on the center of Switch stem.</p> <p>Measurement tool: Contact resistance Meter. (1KHz,20mV,5~50mA)</p> <p>Measured at low current (100mA or less).</p>	100mΩ Max
6.2	Insulation Resistance	<p>Apply a Voltage of DC 500 V for 1 minute, according to the below method.</p> <p>(1) Between terminals. (2) Between terminal and Body.</p>	100mΩ Min
6.3	Dielectric withstanding voltage	<p>Apply a Voltage of AC100 V (50~60Hz) for 1 minute, according to the below method.</p> <p>(1) Between terminals. (2) Between terminal and Body.</p>	No evidence of breakdown
6.4	Bouncing	<p>Operation speed: 3~4 times/s</p> <p>Oscillo scope</p> <p>Switch Bouncing Test Circuit</p>  <p style="text-align: center;">Switch Bouncing Test Circuit</p> <p style="text-align: center;">"ON" "OFF"</p>	<p>Before Life cycle: On: 5ms MAX Off: 5ms MAX</p> <p>After Life cycle: On: 10ms MAX Off: 10ms MAX</p>

7. Mechanical Performance

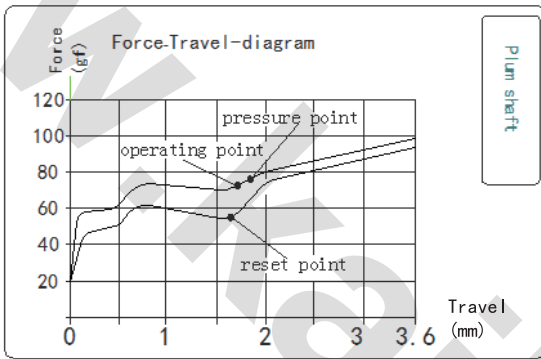
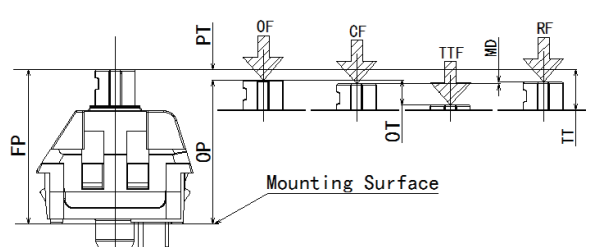
Item	Description	Test Condition	Requirement
7.1	Load Curve	<p>Place the vertical direction of switch operation and gradually increase the load applied to the center of the stem until it stop.</p>  <p>The diagram is a line graph titled 'Force-Travel-diagram'. The vertical axis is labeled 'Force (gf)' and ranges from 0 to 120 in increments of 20. The horizontal axis is labeled 'Travel (mm)' and ranges from 0 to 3.6 in increments of 1. The graph shows two curves: an upper curve representing the loading process and a lower curve representing the unloading process. Key points are marked: 'reset point' at approximately (1.5, 55), 'operating point' at approximately (1.8, 75), and 'pressure point' at approximately (2.0, 85). A vertical box on the right side of the graph is labeled 'Plum shaft'.</p>	See page 11
7.2	Loading parameter	<p>Place the vertical direction of switch operation and gradually increase the load applied to the center of the stem until it stop.</p>  <p>The diagram shows a cross-section of the switch mechanism. On the left, a perspective view shows the 'Mounting Surface'. On the right, a side view shows the internal components. Labels include: 'PT' (Plum shaft tip), 'OF' (Operating force), 'CF' (Contact force), 'TIF' (Total initial force), 'MD' (Mounting distance), 'RF' (Reset force), 'OP' (Operating point), and 'TT' (Total travel).</p>	See page 11

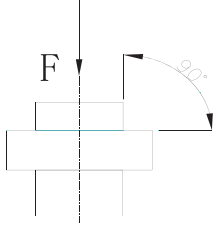
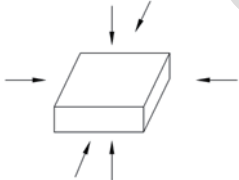
7.3	Static Strength	<p>A static load of 3kgf shall be applied in the direction of button operation for a period of 60 seconds.</p> 	<p>No damage (Electrical) And mechanical</p>
7.4	Stem Pull Strength	<p>Break by a pull force applied opposite to the direction of stem operation.</p>	<p>5kgf Min</p>
7.5	Shock	<p>Measured by according to the below condition: (1) Acceleration: 80g (2) Cycles of test: 3 cycles each in 6 directions, for a total of 18 cycles.</p> 	<p>Shall meet No.6, 7.1, 7.2.</p>
7.6	Life Test	<ol style="list-style-type: none"> 1) D.C.12V 10mA resistance load 2) Operation speed: 5-6 times / s 3) Push force: 150gf 4) Push travel: 3.6mm 5) Operation number: 70,000,000 cycles 	<p>Contact resistance: 1000 mΩ Max Bouncing: 10ms Max Operation force: Variation rate within ±30%</p>

8. Environmental Performance

Item	Description	Test Condition	Requirement												
8.1	Cold test	(1) Temperature: $-20\pm 2^{\circ}\text{C}$ (2) Duration of test: 48h (3) Take off a drop water (4) Standard conditions after test: 1h	Contact resistance: 200m Ω Max Shall meet: No. 6.2 to 6.4 No. 7.1 to 7.2												
8.2	Heat test	(1) Temperature: $70\pm 2^{\circ}\text{C}$ (2) Duration of test: 48h (3) Take off a drop water (4) Standard conditions after test: 1h	Contact resistance: 200m Ω Max Shall meet: No. 6.2 to 6.4 No. 7.1 to 7.2												
8.3	Temperature cycle	(1) Test cycles: 5 cycles (2) Standard condition after test: 1h <table border="1" data-bbox="411 1570 1015 1760"><thead><tr><th></th><th>Temperature</th><th>Duration of test</th></tr></thead><tbody><tr><td rowspan="4">1 cycle</td><td>$20\pm 5^{\circ}\text{C}$</td><td>1h</td></tr><tr><td>$-20\pm 2^{\circ}\text{C}$</td><td>1h</td></tr><tr><td>$20\pm 5^{\circ}\text{C}$</td><td>1h</td></tr><tr><td>$70\pm 5^{\circ}\text{C}$</td><td>1h</td></tr></tbody></table>		Temperature	Duration of test	1 cycle	$20\pm 5^{\circ}\text{C}$	1h	$-20\pm 2^{\circ}\text{C}$	1h	$20\pm 5^{\circ}\text{C}$	1h	$70\pm 5^{\circ}\text{C}$	1h	Contact resistance: 200m Ω Max Shall meet: No. 6.2 to 6.4 No. 7.1 to 7.2
	Temperature	Duration of test													
1 cycle	$20\pm 5^{\circ}\text{C}$	1h													
	$-20\pm 2^{\circ}\text{C}$	1h													
	$20\pm 5^{\circ}\text{C}$	1h													
	$70\pm 5^{\circ}\text{C}$	1h													

8.4

Soldering heat test

Soldering area: T/2 of PWB thickness.
(PWB: T=1.6mm)
Soldering temperature: $260 \pm 5^{\circ}\text{C}$
Soldering time: $5 \pm 0.5\text{s}$

Appearance:
No abnormality.

8.5

Solder ability

1. Hand soldering:
Please practice according to below condition:
(1) Soldering Temperature: $350 \pm 5^{\circ}\text{C}$
(2) Continual soldering time: $3 \pm 0.5\text{s}$
(3) Capacity of soldering iron: $\leq 20\text{w}$

2. Automatic PIP soldering:
For the product of T/H according to below condition:

At least 95% of surface area of immersed portion shall be covered by solder.

Wave Soldering Temperature Curve (Single Wave Peak)

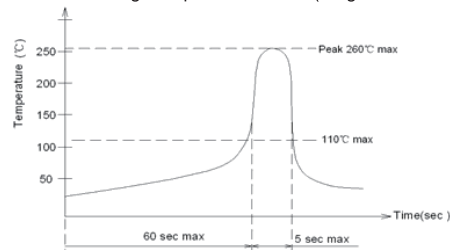

8.6	Humidity test	(1) Temperature: $60\pm 2^{\circ}\text{C}$ (2) relative humidity: 90~95% R.H. (3) Duration of test: 48h (4) Take off a drop water (5) Standard conditions after test: 1h	Contact resistance: 200m Ω Max Shall meet : No. 6.2 to 6.4 No. 7.1 to 7.2
8.7	Salt Spray	Apply the following environment to test: (1) Temperature: $35\pm 5^{\circ}\text{C}$ (2) Salt water density: $5\pm 1\%$ (3) Duration: 12hours (4) After test, the salt deposit shall be removed by running water.	Appearance: No corrosion spot, no crack, no base plate naked. Contact Resistance: 200 m Ω Max
8.8	Withstand K ₂ S	Apply the following environment to test: (1) Temperature: $35\pm 5^{\circ}\text{C}$ (2) K ₂ S Density: 2% (3) Duration: 2 minute.	Appearance: No corrosion spot, no crack, no base plate naked. Contact Resistance: 1000 m Ω Max

9. Recommended PCB Layout

Mounting Options

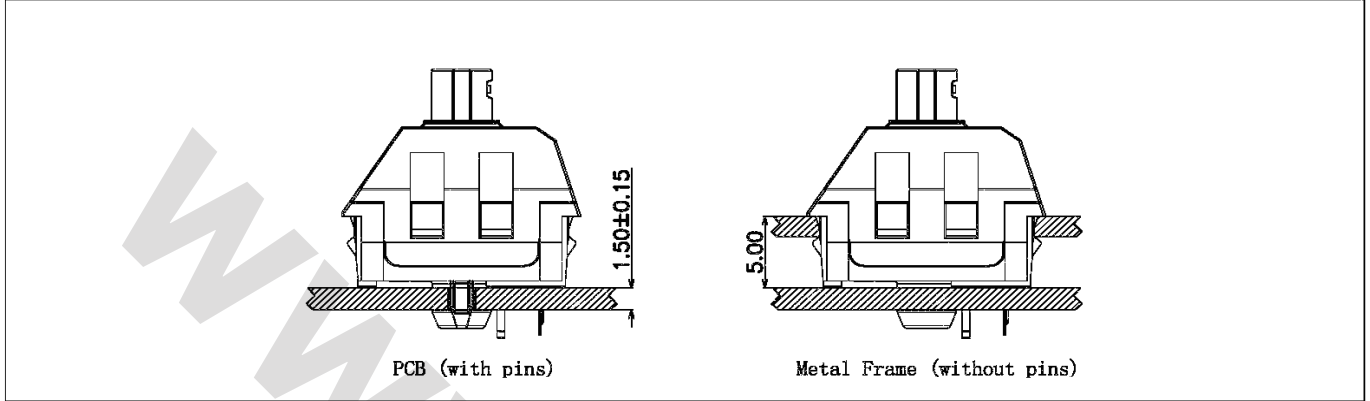

Circuit Board Layouts

Grid line spacing = 1.27mm

Keyswitch without fixation pins

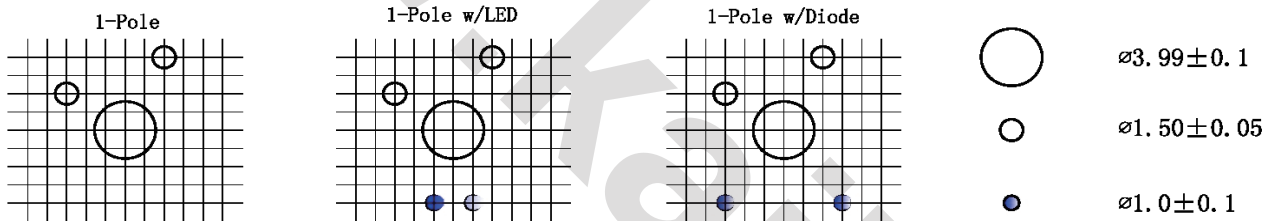

Keyswitch with fixation pins

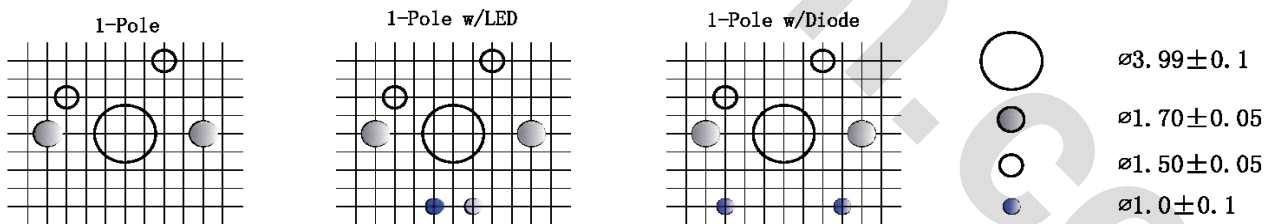

Metal Frame Cutout Dimensions

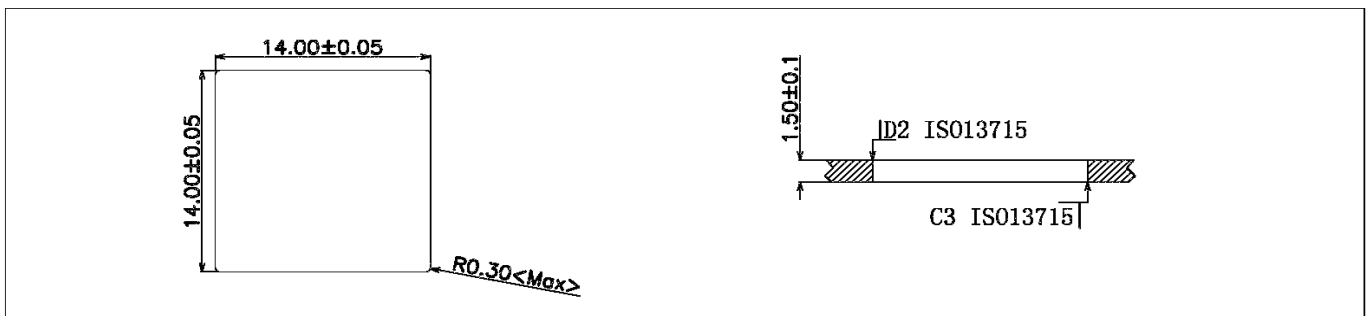

10. Loading Parameter (FP/OP/PT/OT /MD/CF/OF) Specification

Parameter	Unit	Specification	Remark
FP	mm	15.25 ± 0.2	
OP	mm	13.55 ± 0.8	
PT	mm	1.7 ± 0.6	
TF	gf	70 ± 15	
OF	gf	70 ± 15	Min
OT	mm	0.7	Max
MD	mm	0.6	
TT	mm	3.6 ± 0.6	

11. Precaution

11.1 Immersion Soldering condition

ITEM	CONDITION
Preheat temperature	110°C Max (Ambient temperature of soldering surface of P.W.B)
Preheat time	60s, Max
Area of flux	1/2 Max of PWB Thickness
Temperature of solder	260±5°C
Time of immersion	Within 5s
Number of soldering	2time Max (But should down heat of the first soldering)
Printed wiring board	Single side copper-clad laminates

- (1) After switches were soldered, please be careful not to clean switches with solvent
- (2) Under the condition of using soldering iron, soldering temperature shall be 350°C max within 3 sec.

11.2 Notes

- (1) Please be cautious not to give excessive static load or shock to switches.
- (2) Please be careful not to stack up P. W. B. after switches were soldered.
- (3) Preservation under high temperature and high humidity or corrosive gas should be avoided Especially.
When you need to preserve for a long period, do not open the carton.
- (4) Products meet the ROHS & REACH environmental management substances control standards.