



**Kailh**

**KAIHUA ELECTRONICS**

Document Number:

**KH-PS1706-31**

# Product Specification

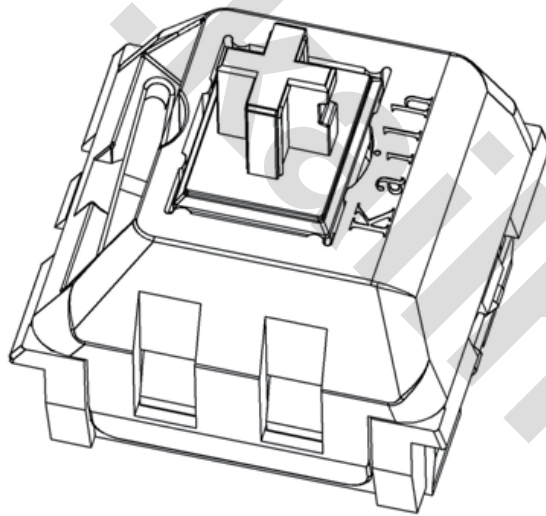

P/N:

**CPG151101D223**

Title :

**PG1511 Keyboard Switch**

<b>P/N:</b> CPG151101D223	<b>DOC. No.:</b> KH-PS1706-31	<b>Rev.:</b> A	<b>Page:</b> 2/11
------------------------------	----------------------------------	-------------------	----------------------

## Content

1. Scope .....	3
2. Product Application .....	3
3. Technology Parameters .....	3
4. Ratings .....	3
5. Profile Dimensions .....	3
6. Electrical Performance .....	4
7. Mechanical Performance .....	5~6
8. Environmental Performance .....	7~9
9. Recommended PCB Layout .....	10
10. Loading Parameter Specification .....	11
11. Precaution .....	11

<b>P/N:</b> CPG151101D223	<b>DOC. No.:</b> KH-PS1706-31	<b>Rev.:</b> A	<b>Page:</b> 3/11
------------------------------	----------------------------------	-------------------	----------------------

### 1. Scope:

This Product Specification covers the requirement of Mechanical Keyboard switch on product performance, test methods and quality assurance provisions.

### 2. Product Application:

Mainly applied on computer keyboards, cash registers, industrial equipment and Man-Machine interface.

### 3. Technology Parameters:

Ambient Humidity: 45 ~ 85% RH

Operating Temperature Range:  $-10^{\circ}\text{C} \sim +70^{\circ}\text{C}$

Storage Temperature Range:  $-20^{\circ}\text{C} \sim +70^{\circ}\text{C}$

Suggested storage period: about 6 months

Require the tin part on the switch terminals should keep good after storage guarantee date

Normal Condition:

Ambient temperature:  $20 \pm 2^{\circ}\text{C}$

Relative humidity:  $65\% \pm 5\% \text{RH}$

Air pressure: 86~101KPa

### 4. Ratings

Rating: 12V AC/DC max. 2V DC min

10mA AC/DC max. 10 $\mu$ A DC min

Insulation Resistance:  $\geq 100\text{M}\Omega/\text{DC } 100\text{V}$

Withstand Voltage: 100 AC 1 Minute

Mechanical Life: 70,000,000 Cycles

### 5. Profile Dimensions

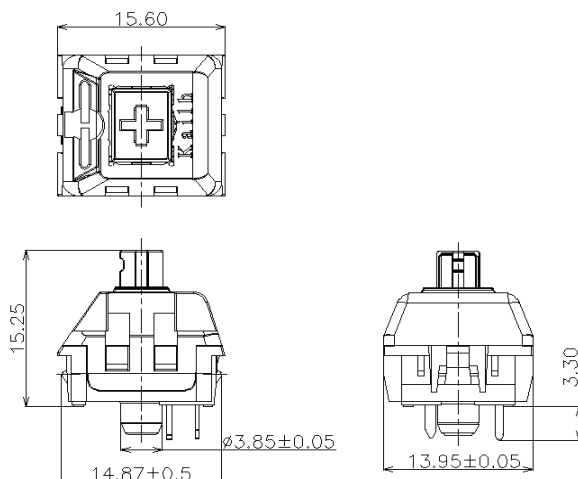

### 6. Electrical Performance

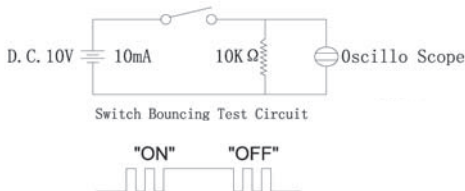
Item	Description	Test Condition	Requirement
6.1	Contact Resistance	<p>Static load: (Operation force)x2, which is applied on the center of Switch stem.</p> <p>Measurement tool: Contact resistance Meter. (1KHz,20mV,5~50mA)</p> <p>Measured at low current (100mA or less).</p>	100mΩ Max
6.2	Insulation Resistance	<p>Apply a Voltage of DC 500 V for 1 minute, according to the below method.</p> <p>(1) Between terminals. (2) Between terminal and Body.</p>	100mΩ Min
6.3	Dielectric withstanding voltage	<p>Apply a Voltage of AC100 V (50~60Hz) for 1 minute, according to the below method.</p> <p>(1) Between terminals. (2) Between terminal and Body.</p>	No evidence of breakdown
6.4	Bouncing	<p>Operation speed: 3~4 times/s</p> <p>Oscillo scope</p> <p>Switch Bouncing Test Circuit</p>  <p style="text-align: center;">Switch Bouncing Test Circuit</p> <p style="text-align: center;">"ON"      "OFF"</p>	<p>Before Life cycle: On: 5ms MAX Off: 5ms MAX</p> <p>After Life cycle: On: 10ms MAX Off: 10ms MAX</p>

**7. Mechanical Performance**

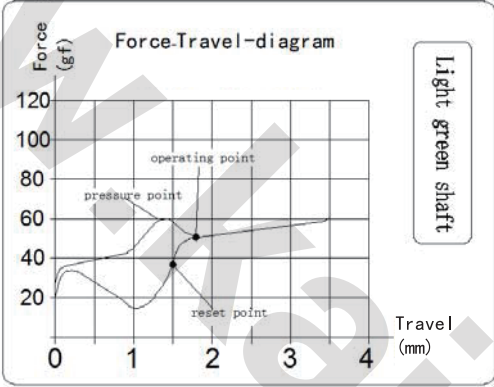
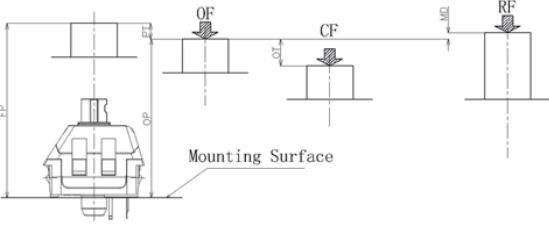
Item	Description	Test Condition	Requirement
7.1	Load Curve	<p>Place the vertical direction of switch operation and gradually increase the load applied to the center of the stem until it stop.</p> 	See page 11
7.2	Loading parameter	<p>Place the vertical direction of switch operation and gradually increase the load applied to the center of the stem until it stop.</p> 	See page 11

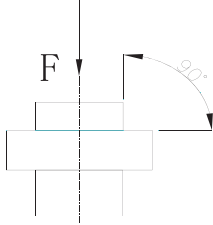
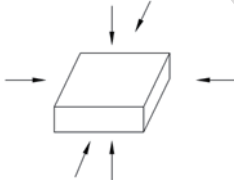
7.3	Static Strength	<p>A static load of 3kgf shall be applied in the direction of button operation for a period of 60 seconds.</p> 	<p>No damage (Electrical) And mechanical</p>
7.4	Stem Pull Strength	<p>Break by a pull force applied opposite to the direction of stem operation.</p>	<p>5kgf Min</p>
7.5	Shock	<p>Measured by according to the below condition: (1) Acceleration: 80g (2) Cycles of test: 3 cycles each in 6 directions, for a total of 18 cycles.</p> 	<p>Shall meet No.6, 7.1, 7.2.</p>
7.6	Life Test	<ol style="list-style-type: none"> <li>1) D.C.12V 10mA resistance load</li> <li>2) Operation speed: 5-6 times / s</li> <li>3) Push force: 150gf</li> <li>4) Push travel: 3.6mm</li> <li>5) Operation number: 70,000,000 cycles</li> </ol>	<p>Contact resistance: 200 mΩ Max Bouncing: 10ms Max Operation force: Variation rate within ±30%</p>

#### 8. Environmental Performance

Item	Description	Test Condition	Requirement												
8.1	Cold test	(1) Temperature: $-20\pm 2^{\circ}\text{C}$ (2) Duration of test: 48h (3) Take off a drop water (4) Standard conditions after test: 1h	Contact resistance: 200mΩ Max Shall meet: No. 6.2 to 6.4 No. 7.1 to 7.2												
8.2	Heat test	(1) Temperature: $70\pm 2^{\circ}\text{C}$ (2) Duration of test: 48h (3) Take off a drop water (4) Standard conditions after test: 1h	Contact resistance: 200mΩ Max Shall meet: No. 6.2 to 6.4 No. 7.1 to 7.2												
8.3	Temperature cycle	(1) Test cycles: 5 cycles (2) Standard condition after test: 1h  <table border="1"> <thead> <tr> <th></th> <th>Temperature</th> <th>Duration of test</th> </tr> </thead> <tbody> <tr> <td rowspan="4">1 cycle</td> <td><math>20\pm 5^{\circ}\text{C}</math></td> <td>1h</td> </tr> <tr> <td><math>-20\pm 2^{\circ}\text{C}</math></td> <td>1h</td> </tr> <tr> <td><math>20\pm 5^{\circ}\text{C}</math></td> <td>1h</td> </tr> <tr> <td><math>70\pm 5^{\circ}\text{C}</math></td> <td>1h</td> </tr> </tbody> </table>		Temperature	Duration of test	1 cycle	$20\pm 5^{\circ}\text{C}$	1h	$-20\pm 2^{\circ}\text{C}$	1h	$20\pm 5^{\circ}\text{C}$	1h	$70\pm 5^{\circ}\text{C}$	1h	Contact resistance: 200mΩ Max Shall meet: No. 6.2 to 6.4 No. 7.1 to 7.2
	Temperature	Duration of test													
1 cycle	$20\pm 5^{\circ}\text{C}$	1h													
	$-20\pm 2^{\circ}\text{C}$	1h													
	$20\pm 5^{\circ}\text{C}$	1h													
	$70\pm 5^{\circ}\text{C}$	1h													



8.4

Soldering heat test

Soldering area: T/2 of PWB thickness.  
(PWB: T=1.6mm)  
Soldering temperature:  $260 \pm 5^\circ\text{C}$   
Soldering time:  $3 \pm 0.5\text{s}$

Appearance:  
No abnormality.

8.5

Solder ability

1. Hand soldering:  
Please practice according to below condition:  
(1) Soldering Temperature:  $350 \pm 5^\circ\text{C}$   
(2) Continual soldering time:  $3 \pm 0.5\text{s}$   
(3) Capacity of soldering iron:  $\leq 20\text{w}$

2. Automatic PIP soldering:  
For the product of T/H according to below condition:

At least 95% of surface area of immersed portion shall be covered by solder.

Wave Soldering Temperature Curve (Single Wave Peak)

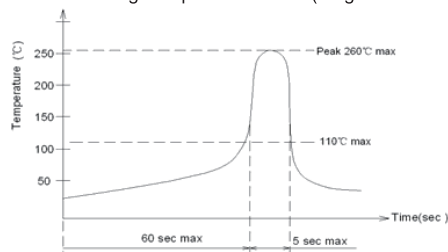

8.6	Humidity test	(1) Temperature: $60\pm 2^{\circ}\text{C}$ (2) relative humidity: 90~95% R.H. (3) Duration of test: 48h (4) Take off a drop water (5) Standard conditions after test: 1h	Contact resistance: 200m $\Omega$ Max Shall meet : No. 6.2 to 6.4 No. 7.1 to 7.2
8.7	Salt Spray	Apply the following environment to test: (1) Temperature: $35\pm 5^{\circ}\text{C}$ (2) Salt water density: $5\pm 1\%$ (3) Duration: 12hours (4) After test, the salt deposit shall be removed by running water.	Appearance: No corrosion spot, no crack, no base plate naked. Contact Resistance: 200 m $\Omega$ Max
8.8	Withstand $\text{K}_2\text{S}$	Apply the following environment to test: (1) Temperature: $35\pm 5^{\circ}\text{C}$ (2) $\text{K}_2\text{S}$ Density: 2% (3) Duration: 2 minute.	Appearance: No corrosion spot, no crack, no base plate naked. Contact Resistance: 1000 m $\Omega$ Max

<b>P/N:</b> CPG151101D223	<b>DOC. No.:</b> KH-PS1706-31	<b>Rev.:</b> A	<b>Page:</b> 10/11
------------------------------	----------------------------------	-------------------	-----------------------

### 9. Recommended PCB Layout

#### Mounting Options

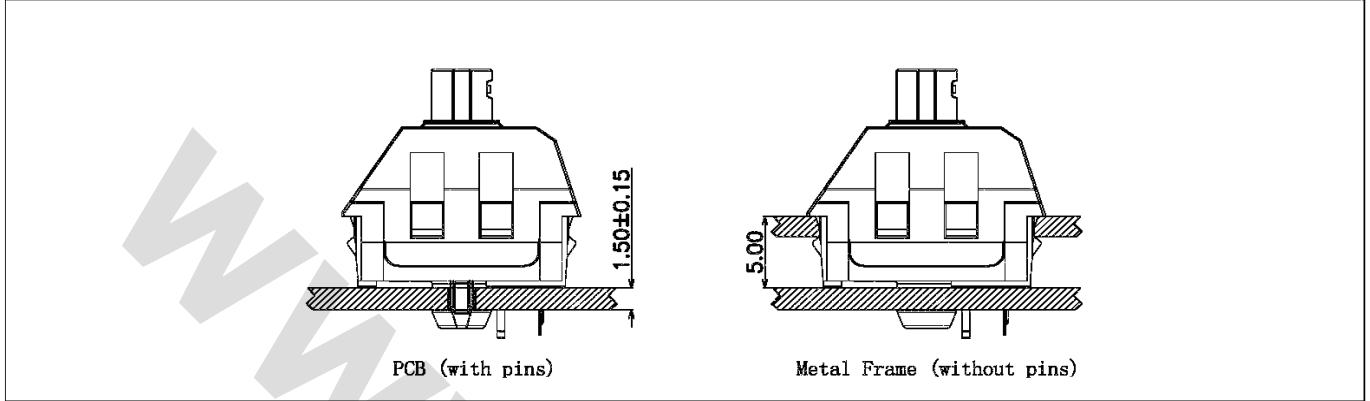

#### Circuit Board Layouts

Grid line spacing = 1.27mm

##### Keyswitch without fixation pins

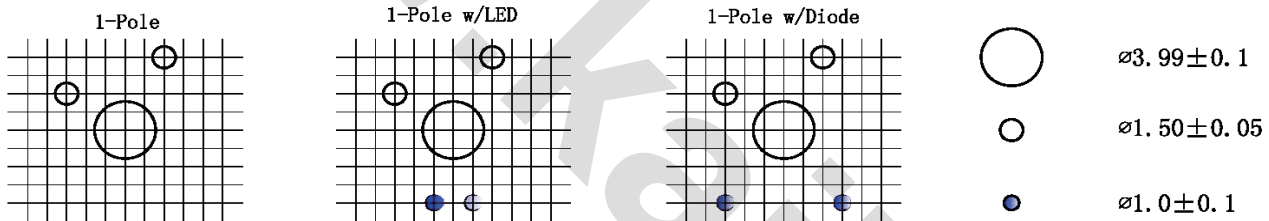

##### Keyswitch with fixation pins

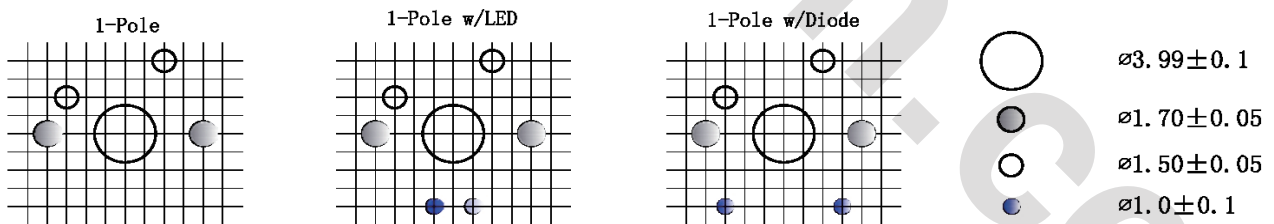

#### Metal Frame Cutout Dimensions

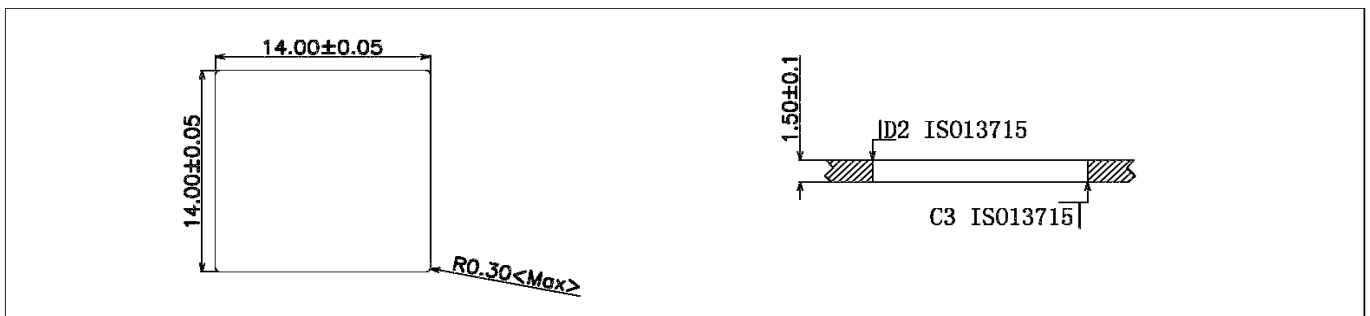

### 10. Loading Parameter (FP/OP/PT/OT /MD/CF/OF) Specification

Parameter	Unit	Specification	Remark
FP	mm	15.25 ± 0.2	
OP	mm	11.25 ± 0.7	
PT	mm	1.70 ± 0.5	
OF	gf	50 ± 10	
OT	mm	1.7	Min
MD	mm	2.3	Max
TF	gf	60 ± 10	
TT	mm	3.6 ± 0.6	

### 11. Precaution

#### 11.1 Immersion Soldering condition

ITEM	CONDITION
Preheat temperature	110°C Max (Ambient temperature of soldering surface of P.W.B)
Preheat time	60s, Max
Area of flux	1/2 Max of PWB Thickness
Temperature of solder	260±5°C
Time of immersion	Within 5s
Number of soldering	2time Max (But should down heat of the first soldering)
Printed wiring board	Single side copper-clad laminates

- (1) After switches were soldered, please be careful not to clean switches with solvent
- (2) Under the condition of using soldering iron, soldering temperature shall be 350°C max within 3 sec.

#### 11.2 Notes

- (1) Please be cautious not to give excessive static load or shock to switches.
- (2) Please be careful not to stack up P. W. B. after switches were soldered.
- (3) Preservation under high temperature and high humidity or corrosive gas should be avoided Especially.  
When you need to preserve for a long period, do not open the carton.
- (4) Products meet the ROHS & REACH environmental management substances control standards.