

ABIDE BY ROHS

Silver shaft

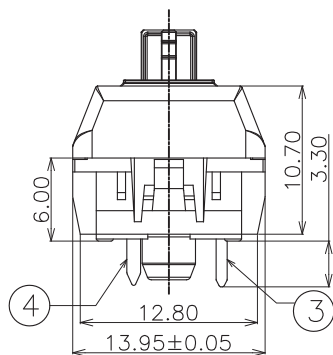

SWITCH FUNCTION

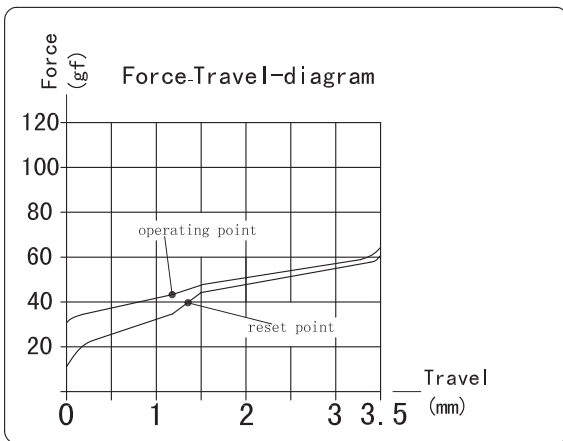
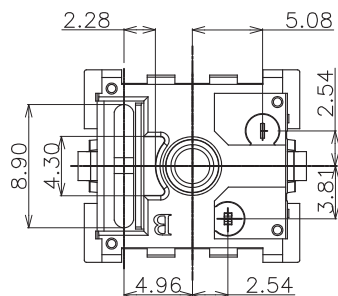
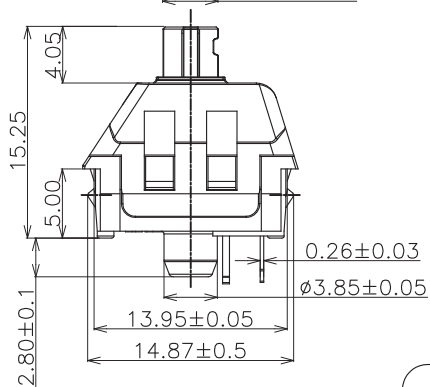
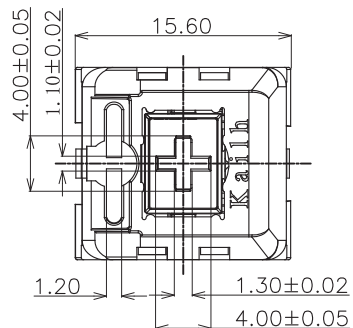
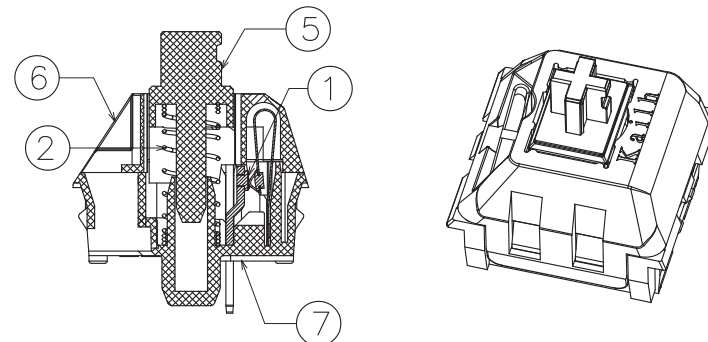
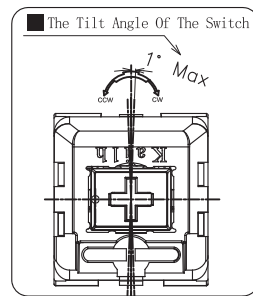
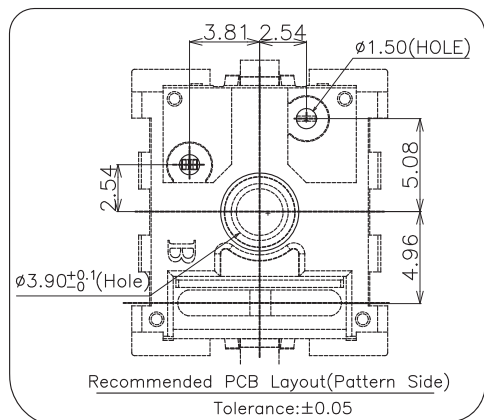
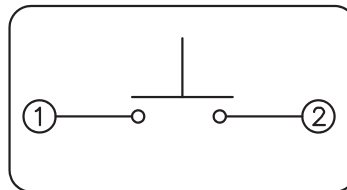

Specification :

- 1. Rating : 12V AC/DC max. 2V DC min. 10mA AC/DC max. 10µA DC min.
- 2. Contact Resistance : 100mΩ Max
- 3. Insulation Resistance : 100MΩ Min (DC500V)
- 4. Withstand Voltage : AC100V (50-60Hz) for 1 minute
- 5. Bounce Time : ≤5msec (at 16 in/sec. actuation speed)
- 6. Operation Force : 40±10gf
- 7. Pre travel: 1.1±0.4mm
- 8. Total travel: 3.5±0.4mm
- 9. Operating Life : 70,000,000 Cycles (min).

⑦	Base	1	PA66	White	
⑥	contact	2	Composite gold		
⑤	Spring	1	Stainless Steel		
④	Cover	1	PC		
③	Keystroke	1	POM	Silver	
②	static plate	1	Brass	sn plating	
①	movable plate	1	Copper Alloy		
ITEM	PART NAME	TER'NO.QTY.	MATERIAL	FINISHING	REMARK

APPROVALS		DATE		Kailh KATHUA ELECTRONICS CO., LTD			
DRAWN	YI JIN PING	2017.04.13					
CHECKED				TITLE:	PG1511 Keystroke Switch(Golden shaft)		
APPROVALS				PART NO.	CPG151101D212		
TOLERANCES ARE		30<L	±0.30	ANGLE	UNIT: mm	SCALE: 1:1	PROJ:
		10<L	±0.20				
		5<L	±0.15	±2'	DRAWING NO.	KHA-PG1511-166	SHEET 1 OF 1
		L	±0.10				

ECN NO.	REV.	DATE.	NEW DESCRIPTION.	CHANGE.	CHECK.	APPRO.
---------	------	-------	------------------	---------	--------	--------

Kailh

KAIHUA ELECTRONICS

Document Number:

KH-PS1705-22

Product Specification

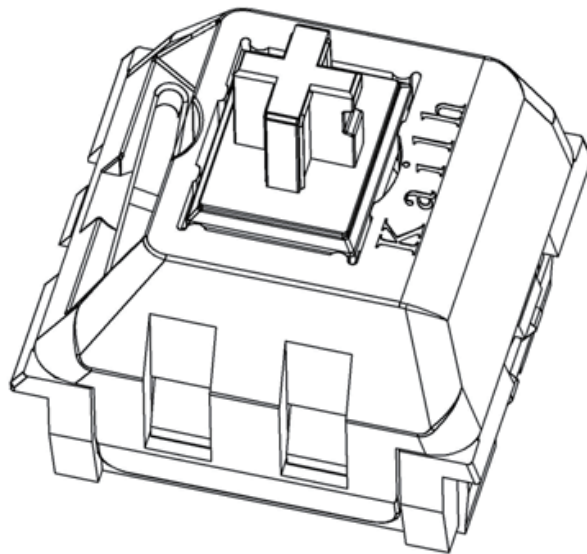

P/N:

CPG151101D212

Title :

PG1511 Keyboard Switch

P/N: CPG151101D212	DOC. No.: KH-PS1705-22	Rev.: C	Page: 2/11
------------------------------	----------------------------------	-------------------	----------------------

Content

1. Scope	3
2. Product Application	3
3. Technology Parameters	3
4. Ratings	3
5. Profile Dimensions	3
6. Electrical Performance	4
7. Mechanical Performance	5~6
8. Environmental Performance	7~9
9. Recommended PCB Layout	10
10. Loading Parameter Specification	11
11. Precaution	11

P/N: CPG151101D212	DOC. No.: KH-PS1705-22	Rev.: C	Page: 3/11
------------------------------	----------------------------------	-------------------	----------------------

1. Scope:

This Product Specification covers the requirement of Mechanical Keyboard switch on product performance, test methods and quality assurance provisions.

2. Product Application:

Mainly applied on computer keyboards, cash registers, industrial equipment and Man-Machine interface.

3. Technology Parameters:

Ambient Humidity: 45 ~ 85% RH

Operating Temperature Range: -10°C ~ +70°C

Storage Temperature Range: -20°C ~ +70°C

Suggested storage period: about 6 months

Require the tin part on the switch terminals should keep good after storage guarantee date

Normal Condition:

Ambient temperature: 20±2°C

Relative humidity: 65%±5%RH

Air pressure: 86~101KPa

4. Ratings

Rating: 12V AC/DC max. 2V DC min

10mA AC/DC max. 10μA DC min

Insulation Resistance: ≥100MΩ/DC 500V

Withstand Voltage: 100 AC 1 Minute

Mechanical Life: 70,000,000 Cycles

5. Profile Dimensions

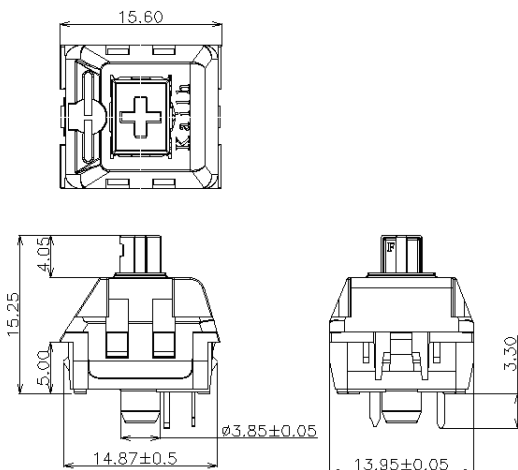

6. Electrical Performance

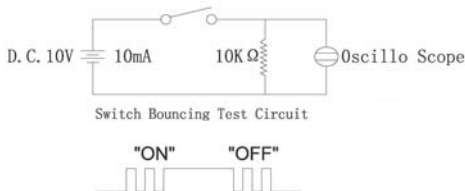
Item	Description	Test Condition	Requirement
6.1	Contact Resistance	<p>Static load: (Operation force)x2, which is applied on the center of Switch stem.</p> <p>Measurement tool: Contact resistance Meter. (1KHz,20mV,5~50mA)</p> <p>Measured at low current (100mA or less).</p>	100mΩ Max
6.2	Insulation Resistance	<p>Apply a Voltage of DC 500 V for 1 minute, according to the below method.</p> <p>(1) Between terminals. (2) Between terminal and Body.</p>	100mΩ Min
6.3	Dielectric withstanding voltage	<p>Apply a Voltage of AC100 V (50~60Hz) for 1 minute, according to the below method.</p> <p>(1) Between terminals. (2) Between terminal and Body.</p>	No evidence of breakdown
6.4	Bouncing	<p>Operation speed: 3~4 times/s</p> <p>Oscillo scope</p> <p>Switch Bouncing Test Circuit</p> 	<p>Before Life cycle: On: 5ms MAX Off: 5ms MAX</p> <p>After Life cycle: On: 10ms MAX Off: 10ms MAX</p>

7. Mechanical Performance

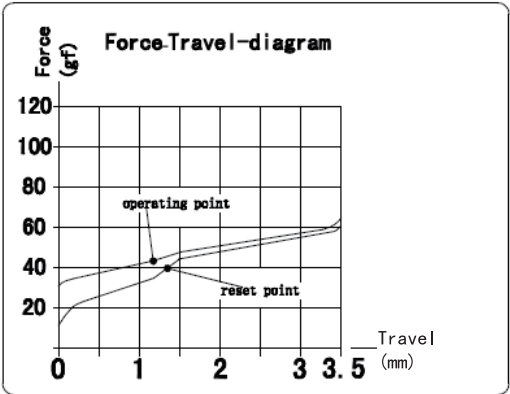
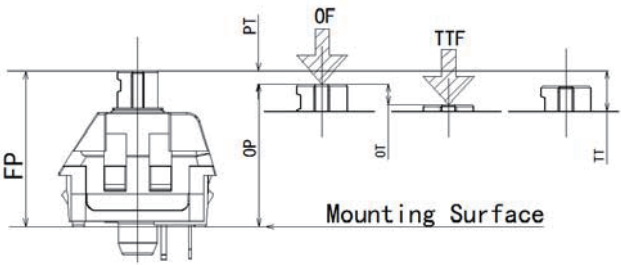
Item	Description	Test Condition	Requirement
7.1	Load Curve	<p>Place the vertical direction of switch operation and gradually increase the load applied to the center of the stem until it stop.</p>  <p>The graph shows two curves: one for the operating point and one for the reset point. The operating point curve starts at approximately 20 gf at 0 mm travel and reaches about 60 gf at 3.5 mm travel. The reset point curve starts at approximately 40 gf at 0 mm travel and reaches about 60 gf at 3.5 mm travel. The operating point is marked at approximately 1.2 mm travel and 40 gf, and the reset point is marked at approximately 1.5 mm travel and 40 gf.</p>	See page 11
7.2	Loading parameter	<p>Place the vertical direction of switch operation and gradually increase the load applied to the center of the stem until it stop.</p>  <p>The diagram shows a cross-section of the switch with various dimensions and force application points. The mounting surface is indicated. Dimensions include FP (total height), OP (operating point height), PT (total travel), OF (operating force), TTF (total travel force), and FI (final force). Arrows indicate the direction of force application.</p>	See page 11

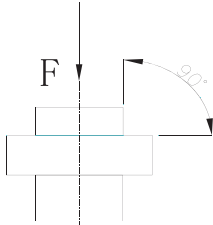
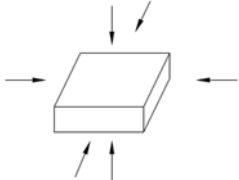
7.3	Static Strength	<p>A static load of 3kgf shall be applied in the direction of button operation for a period of 60 seconds.</p> 	<p>No damage (Electrical) And mechanical</p>
7.4	Stem Pull Strength	<p>Break by a pull force applied opposite to the direction of stem operation.</p>	<p>5kgf Min</p>
7.5	Shock	<p>Measured by according to the below condition: (1) Acceleration: 80g (2) Cycles of test: 3 cycles each in 6 directions, for a total of 18 cycles.</p> 	<p>Shall meet No.6, 7.1, 7.2.</p>
7.6	Life Test	<ol style="list-style-type: none"> 1) D.C.12V 10mA resistance load 2) Operation speed: 5-6 times / s 3) Push force: 150gf 4) Push travel: 3.5mm 5) Operation number: 70,000,000 cycles 	<p>Contact resistance: 1000mΩ Max Bouncing: 10ms Max Operation force: Variation rate within ±30%</p>

8. Environmental Performance

Item	Description	Test Condition	Requirement												
8.1	Cold test	(1) Temperature: $-20\pm 2^{\circ}\text{C}$ (2) Duration of test: 48h (3) Take off a drop water (4) Standard conditions after test: 1h	Contact resistance: 200mΩ Max Shall meet: No. 6.2 to 6.4 No. 7.1 to 7.2												
8.2	Heat test	(1) Temperature: $70\pm 2^{\circ}\text{C}$ (2) Duration of test: 48h (3) Take off a drop water (4) Standard conditions after test: 1h	Contact resistance: 200mΩ Max Shall meet: No. 6.2 to 6.4 No. 7.1 to 7.2												
8.3	Temperature cycle	(1) Test cycles: 5 cycles (2) Standard condition after test: 1h <table border="1" data-bbox="411 1563 1015 1758"> <thead> <tr> <th></th> <th>Temperature</th> <th>Duration of test</th> </tr> </thead> <tbody> <tr> <td rowspan="4">1 cycle</td> <td>$20\pm 5^{\circ}\text{C}$</td> <td>1h</td> </tr> <tr> <td>$-20\pm 2^{\circ}\text{C}$</td> <td>1h</td> </tr> <tr> <td>$20\pm 5^{\circ}\text{C}$</td> <td>1h</td> </tr> <tr> <td>$70\pm 5^{\circ}\text{C}$</td> <td>1h</td> </tr> </tbody> </table>		Temperature	Duration of test	1 cycle	$20\pm 5^{\circ}\text{C}$	1h	$-20\pm 2^{\circ}\text{C}$	1h	$20\pm 5^{\circ}\text{C}$	1h	$70\pm 5^{\circ}\text{C}$	1h	Contact resistance: 200mΩ Max Shall meet: No. 6.2 to 6.4 No. 7.1 to 7.2
	Temperature	Duration of test													
1 cycle	$20\pm 5^{\circ}\text{C}$	1h													
	$-20\pm 2^{\circ}\text{C}$	1h													
	$20\pm 5^{\circ}\text{C}$	1h													
	$70\pm 5^{\circ}\text{C}$	1h													

8.4

Soldering heat test

Soldering area: T/2 of PWB thickness.
(PWB: T=1.6mm)
Soldering temperature: $260 \pm 5^{\circ}\text{C}$
Soldering time: $5 \pm 0.5\text{s}$

Appearance:
No abnormality.

8.5

Solder ability

1. Hand soldering:
Please practice according to below condition:
(1) Soldering Temperature: $350 \pm 5^{\circ}\text{C}$
(2) Continual soldering time: $3 \pm 0.5\text{s}$
(3) Capacity of soldering iron: $\leq 20\text{w}$

2. Automatic PIP soldering:
For the product of T/H according to below condition:

At least 95% of surface area of immersed portion shall be covered by solder.

Wave Soldering Temperature Curve (Single Wave Peak)

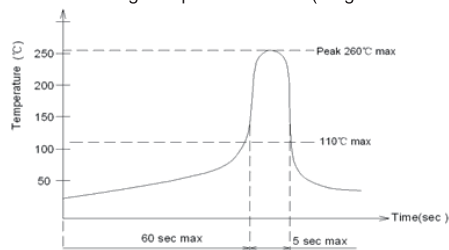

8.6	Humidity test	(1) Temperature: $60\pm 2^{\circ}\text{C}$ (2) relative humidity: 90~95% R.H. (3) Duration of test: 48h (4) Take off a drop water (5) Standard conditions after test: 1h	Contact resistance: 200m Ω Max Shall meet : No. 6.2 to 6.4 No. 7.1 to 7.2
8.7	Salt Spray	Apply the following environment to test (1) Temperature: $35\pm 5^{\circ}\text{C}$ (2) Salt water density: $5\pm 1\%$ (3) Duration: 12hours (4) After test, the salt deposit shall be removed by running water.	Appearance: No corrosion spot, no crack, no base plate naked. Contact Resistance: 200 m Ω Max
8.8	Withstand K_2S	Apply the following environment to test: (1) Temperature: $35\pm 5^{\circ}\text{C}$ (2) K_2S Density: 2% (3) Duration: 2 minute.	Appearance: No corrosion spot, no crack, no base plate naked. Contact Resistance: 1000 m Ω Max

P/N: CPG151101D212	DOC. No.: KH-PS1705-22	Rev.: C	Page: 10/11
------------------------------	----------------------------------	-------------------	-----------------------

9. Recommended PCB Layout

Mounting Options

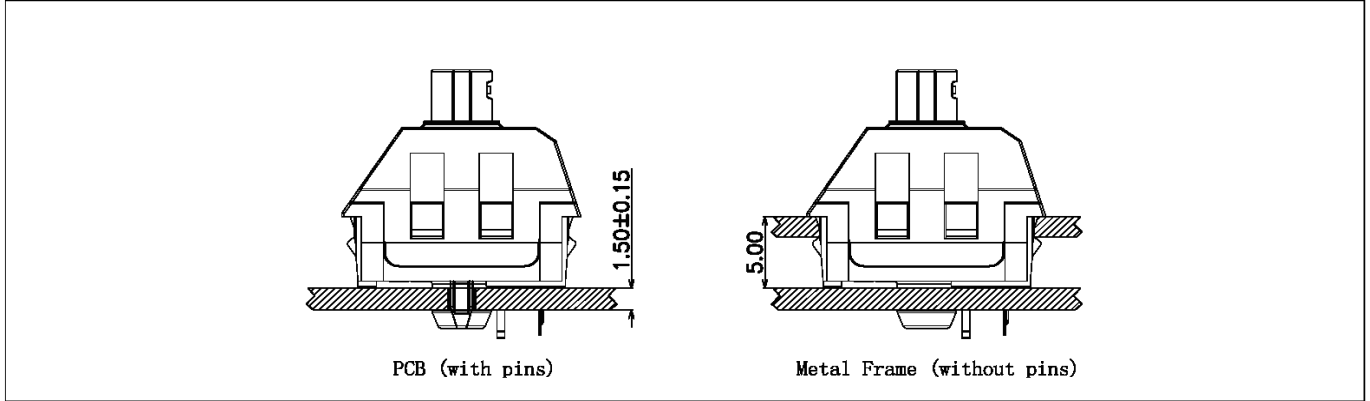

Circuit Board Layouts

Grid line spacing = 1.27mm

Keyswitch without fixation pins

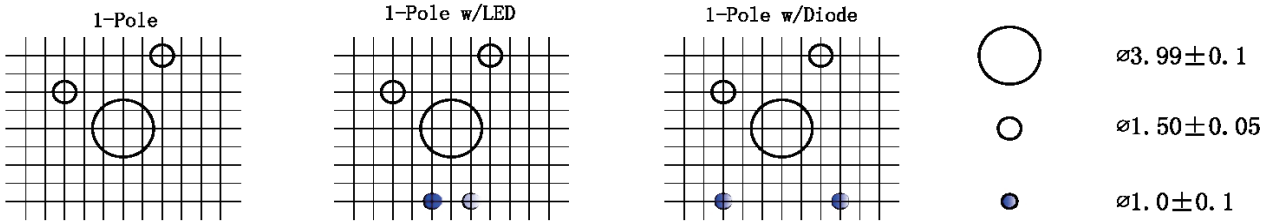

Keyswitch with fixation pins

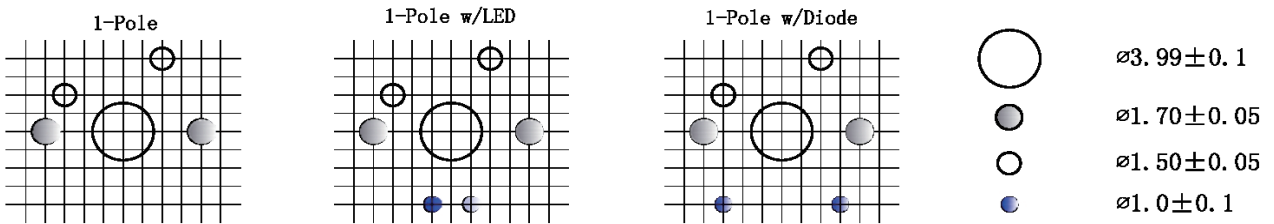

Metal Frame Cutout Dimensions

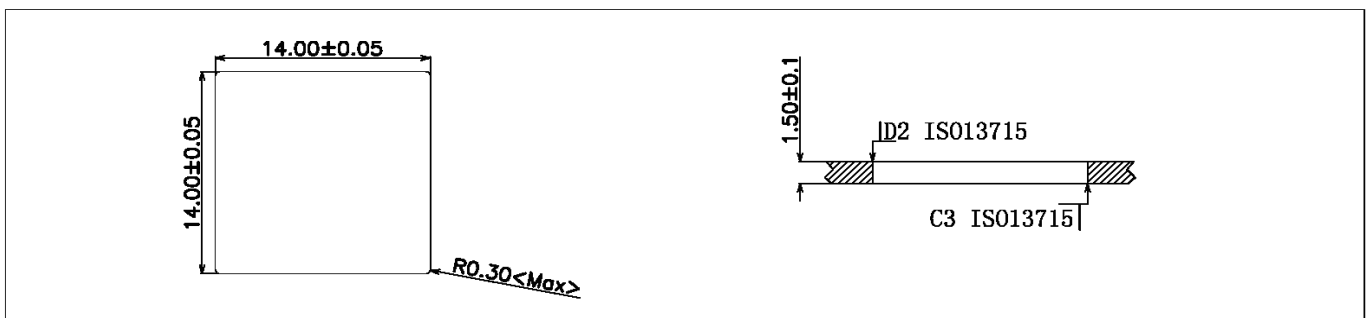

10. Loading Parameter (FP/OP/PT/ OF /OT) Specification

Parameter	Unit	Specification	Remark
FP	mm	15.25 ± 0.2	
OP	mm	14.15 ± 0.6	
PT	mm	1.1 ^{+0.4} _{-0.2}	
OF	gf	40 ± 10	
OT	mm	2.0	Min
TT	mm	3.5 ± 0.4	

11. Precaution

11.1 Immersion Soldering condition

ITEM	CONDITION
Preheat temperature	110°C Max (Ambient temperature of soldering surface of P.W.B)
Preheat time	60s, Max
Area of flux	1/2 Max of PWB Thickness
Temperature of solder	260±5°C
Time of immersion	Within 5s
Number of soldering	2time Max (But should down heat of the first soldering)
Printed wiring board	Single side copper-clad laminates

- (1) After switches were soldered, please be careful not to clean switches with solvent
- (2) Under the condition of using soldering iron, soldering temperature shall be 350°C max within 3 sec.

11.2 Notes

- (1) Please be cautious not to give excessive static load or shock to switches.
- (2) Please be careful not to stack up P. W. B. after switches were soldered.
- (3) Preservation under high temperature and high humidity or corrosive gas should be avoided Especially.
When you need to preserve for a long period, do not open the carton.
- (4) Products meet the ROHS & REACH environmental management substances control standards.