

ABIDE BY ROHS

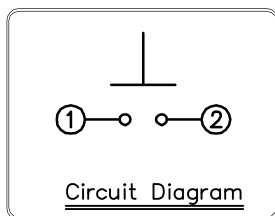
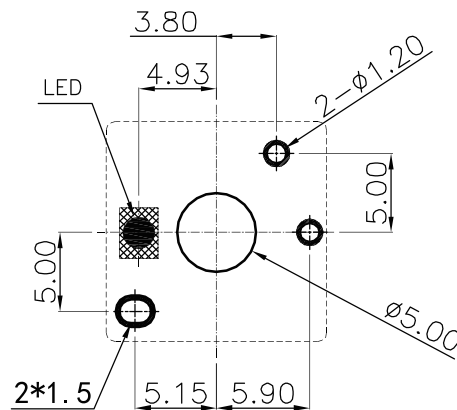
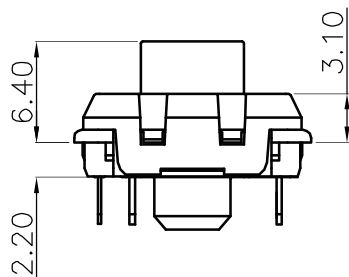
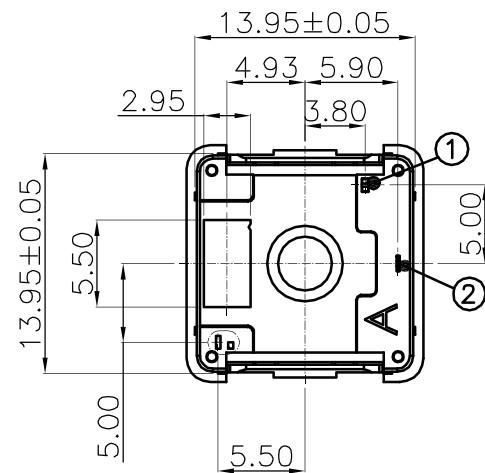
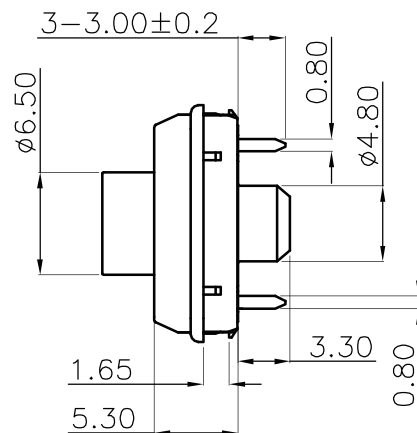
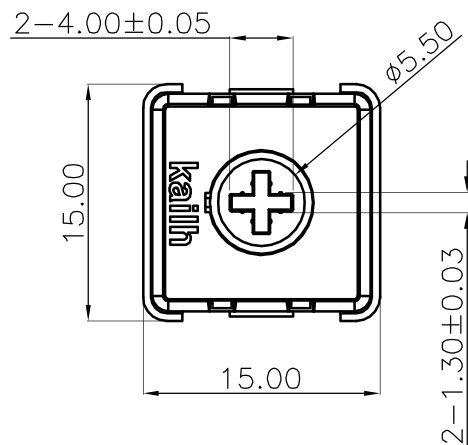

Recommended PCB Layout
(Pattern Side)

Specification :

1. Rating :12DC 10mA
2. Contact Resistance : 200mΩ Max
3. Insulation Resistance :100MΩ Min (DC100V)
4. Withstand Voltage :AC100V (50-60Hz) for 1 minute
5. Operation Force :43±10gf
6. Return force: 15gf min
7. Conduction travel:1.3mm±0.30mm
8. Total travel: 3.2±0.25mm
9. Operating Life(Resistance load DC12V 10mA) :
50,000,000 Cycles

ITEM	PART NAME	TER' NO.	QTY.	MATERIAL	FINISHING	REMARK
APPROVALS			DATE	Kailh KAIHUA ELECTRONICS CO.,LTD		
DRAWN	Lv Pan Hao	2019.10.25				
CHECKED				TITLE:	PG1353 Keyboard Switch(Red Switch)	
APPROVALS				PART NO.	CPG135301D01	
TOLERANCES ARE			30<L	±0.30	ANGLE	UNIT: mm
			10<L	±0.20		
			5<L	±0.15		
			L≤5	±0.10		
			±2'	DRAWING NO.	KHA-PG1353-*****	PROJ:
				SCALE: 1:1	SHEET 1 OF 1	

ECN NO.	REV.	DATE.	DESCRIPTION.	CHANGE.	CHECK.	APPRO.
	A	2020.04.15	NEW			

ABIDE BY ROHS

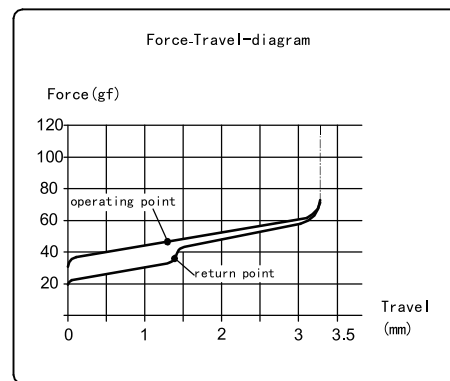
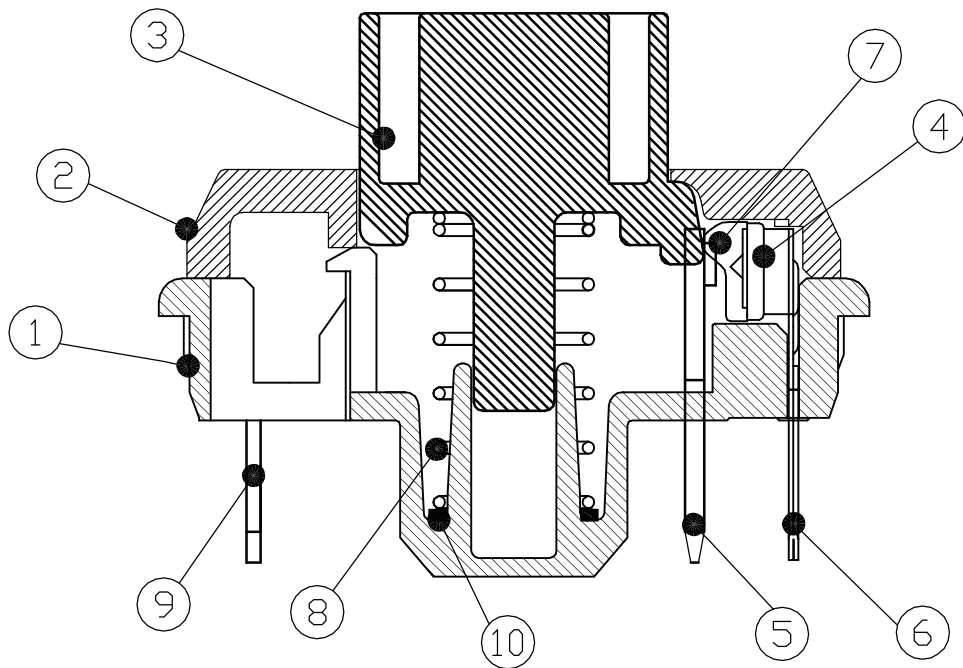
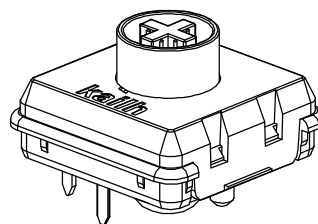

ITEM	PART NAME	TER' NO.	QTY.	MATERIAL	FINISHING	REMARK
10	Grease	—	—	EC10	Natural	0.005-0.01g
9	Terminal	—	1	Phosphor Bronze	Natural	—
8	Spring	—	1	Stainless Steel	Natural	—
7	Contact	—	2	Composite materials	Natural	—
6	Terminal	1	1	Phosphor Bronze	Natural	—
5	Terminal	1	1	Brass	Sn+Ni	Ni:12-25u" Sn:80-150u"
4	Active button	—	1	Nylon	Gray	—
3	Keystoke	—	1	POM	Red	—
2	Cover	—	1	PC	Natural	—
1	Base	—	1	Nylon	Black	—

APPROVALS		DATE	Kailh KAIHUA ELECTRONICS CO.,LTD				
DRAWN	Lv Pan Hao	2019.10.25					
CHECKED			TITLE:	PG1353 Keyboard Switch (Red Switch)			
APPROVALS			PART NO.	CPG135301D01			
TOLERANCES ARE		30<L	±0.30	ANGLE	UNIT: mm	SCALE: 1:1	PROJ:
		10<L	±0.20				
		5<L	±0.15	DRAWING NO.	KHA-PG1353-*****	SHEET 2 OF 2	
		L≤5	±0.10				DRAWING NO.

ECN NO.	REV.	DATE.	DESCRIPTION.	CHANGE.	CHECK.	APPRO.
	A	2020.04.15	NEW			

4

3

2

1

1. General specification

1.1 Switch action: Push-on type S. P. S. T

1.2 Switch rating: 12 VAC/DC max. 2 VDC min. 10mA AC/DC max. 10μA DC min.

1.3 Operation temperature range: - 40°C ~ +70°C

1.4 Storage temperature range: - 40°C ~ +80°C

1.5 Suggested storage period: about 6 months

Require the tin part on the switch terminals should keep good after storage guarantee date

1.6 Appearance and dimensions: See outside drawing page

1.7 Standard condition Unless otherwise specified, the test and measurements shall be carried out as follows:

Ambient temperature: 20±2°C

Relative humidity: 45% ~ 85%

Air pressure: 86 ~ 106kPa(860~1060mbar)

However, if doubt arises on the decision based on the measured Values under the above-mentioned conditions, the following conditions shall be employed:

Ambient temperature: 20±2°C

Relative humidity: 65±5%

Air pressure: 86 ~ 106kPa(860~1060mbar)

2. Performance

2.1 Electrical characteristics

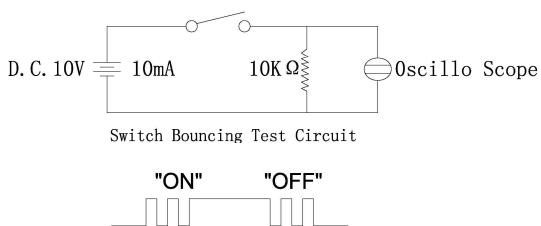
No.	Item	Test condition	Performance
2.1.1	Contact resistance	Push force: (Operation force) x 2. Measurement tool : Contact resistance meter (1kHz, 20mV, 5~50mA)	200mΩ MAX
2.1.2	Insulation resistance	D. C. 100V(Between terminals)	100mΩ min
2.1.3	Withstand voltage	A. C100V for 1 min (Between terminals)	No. insulation destruction.
2.1.4	Bouncing	Operation speed : 3~4 times/s Oscillo scope Switch Bouncing Test Circuit  Switch Bouncing Test Circuit "ON" "OFF"	ON: 5ms max OFF: 5ms max

2.2 Mechanical Characteristics

No.	Item	Test condition	Performance
2.2.1	Operation force Travel to closure		operating force: $43\pm 10\text{gf}$ Return force: 15gf min Full Travel: $3.2\text{mm}\pm 0.25$ Pre Travel: $1.3\text{mm}\pm 0.30$
2.2.2	Push strength	30N(3Kgf)for 15 sec	No damage (Electrical and mechanical)
2.2.3	Pull strength	Break by drawing push plate in the direction of right diagram	30N min (3kgf min)
2.2.4	Vibration test	1) Amplitude: 1.5 mm 2) Sweep rate: 10-55-10HZ for 1 minute 3) Sweep method: Logarithmic frequency sweep rate 4) Vibration direction: X, Y, Z (3 directions) 5) Time: Each direction 2 hours (Total 6 hours)	No.2.1 and 2.2.1 to 2.2.2 shall be satisfied
2.2.5	Soldering heat test	Terminals shall be dipped in the solder bath at $260\pm 5^{\circ}\text{C}$ for 5 ± 1 seconds without additional force for terminals.	No damage (electrical and mechanical)
2.2.6	Solderbility	After sprated flux temperature: $260 \pm 5^{\circ}\text{C}$ soldering time: 2 ± 0.5 sec	90% or more of surface area of the portion immersed in solder shall be covered by new solder
2.2.7	Wobbling of Button	Apply 1N force as shown below	Displacement 0.35mm Max

2.3 Climatic characteristics

No.	Item	Test condition	Performance												
2.3.1	Cold test	1) Temperature: $-40\pm 2^{\circ}\text{C}$ 2) Duration of test: 48h 3) Take off a drop water 4) Standard conditions after test: 1h	Contact resistance 200m Ω max No. 2.1.2 to 2.1.4 and No. 2.2.1 to 2.2.2 shall be satisfied												
2.3.2	Heat test	1) Temperature: $70\pm 2^{\circ}\text{C}$ 2) Duration of test: 48h 3) Standard conditions after test: 1h	Contact resistance 200m Ω max No. 2.1.2 to 2.1.4 and No. 2.2.1 to 2.2.2 shall be satisfied												
2.3.2	Temperature cycle	1) Test cycles: 20 cycles 2) Standard condition after test: 1h <table border="1" data-bbox="552 1252 1150 1509"> <thead> <tr> <th></th> <th>temperature</th> <th>duration of test</th> </tr> </thead> <tbody> <tr> <td rowspan="4">1 cycle</td> <td>$20\pm 5^{\circ}\text{C}$</td> <td>1h</td> </tr> <tr> <td>$-40\pm 2^{\circ}\text{C}$</td> <td>1h</td> </tr> <tr> <td>$20\pm 5^{\circ}\text{C}$</td> <td>1h</td> </tr> <tr> <td>$60\pm 5^{\circ}\text{C}$</td> <td>1h</td> </tr> </tbody> </table>		temperature	duration of test	1 cycle	$20\pm 5^{\circ}\text{C}$	1h	$-40\pm 2^{\circ}\text{C}$	1h	$20\pm 5^{\circ}\text{C}$	1h	$60\pm 5^{\circ}\text{C}$	1h	Contact resistance 200m Ω max No. 2.1.2 to 2.1.4 and No. 2.2.1 to 2.2.2 shall be satisfied
	temperature	duration of test													
1 cycle	$20\pm 5^{\circ}\text{C}$	1h													
	$-40\pm 2^{\circ}\text{C}$	1h													
	$20\pm 5^{\circ}\text{C}$	1h													
	$60\pm 5^{\circ}\text{C}$	1h													
2.3.4	Humidity test	1) Temperature: $70\pm 2^{\circ}\text{C}$ 2) Relative humidity: 90~95% 3) Duration of test: 96h 4) Take off a drop water 5) Standard conditions after test: 1h	Contact resistance 200m Ω max No. 2.1.2 to 2.1.4 and No. 2.2.1 to 2.2.2 shall be satisfied												

No.	Item	Test condition	Performance
2.3.5	Endurance (switching action)	1) D.C.12V 10mA resistance load 2) Operation speed: 10 times / s 3) Push force: 250gf ± 50gf (spring) 4) Operation number: 50,000,000cycles	Contact resistance 1Ω max Bouncing: 10 ms max Variation rate of operation force shall be within ±30% to the value before testing No.2.1.2 and 2.2.2 shall be satisfied
2.3.6	Salt Mist Test	The switch shall be checked after following test: 1. Temperature: 35±5°C 2. Salt solution: 5±1%(Solids by mass) 3. Duration: 24±0.5 hours, 4. After immersing, salt deposit shall be removed by running water.	Contact resistance 200mΩ max No. 2.1.2 to 2.1.4 and No. 2.2.1 to 2.2.2 shall be satisfied
2.3.7	Shock	Measure after test at a condition below Peak acceleration: 80G Test time-6direction, each 3 times total 18 times	No.2.1 and 2.2.1 to 2.2.2 shall be satisfied

3. Acoustic Noise

No.	Item	Test condition	Performance
3.1.1	Acoustic Noise	Background Noise: 20dB Max. Pressing by fingers Sound Level Meter Position 1) Distance: 150mm 2) Vertical: 135mm 3) Angle: 30 deg Drop Height: 2.5mm Operation speed: 1 time/s	Maximum sound while pressing: 30dB

4. Precaution

4.1 Soldering condition

ITEM	CONDITION
Preheat temperature	110°C max (Embilomental temperature of soldering surface of P. W. E)
Preheat time	60 sec, max
Area of flux	1/2 max of P. W. B. thickness
Temperature of solder	260±5°C
Time of immersion	Within 5 sec
Soldering number	Within 2 times (But should bring down heat of the first soldering)

- 1) After switches were soldered, please be careful not to clean switches with solvent.
- 2) In the case of using soldering iron, soldering conditions shall be 350°C max and 3 sec. max.
- 3) Right after switches were soldered; please be careful not to load on the knobs of switches.

4.2 Note

- 1) Please be cautious not to give excessive static load or shock to switches.
- 2) Please be careful not to pile up P. W. B. after switches were soldered.
- 3) Preservation under high temperature and high humidity or corrosive gas should be avoided especially. When you need to preserve for a long period, do not open the carton.
- 4) Panasert RH and RH6 shall be used as the standard insert machine (use N type clinch).
- 5) CONTROL HAZARDOUS SUBSTANCE: THE PRODUCT SHOULD BE MEET ROHS SPECIFICATION.

The explanation for force and travel:

Operation Force: The pressing force while conduction

Return force: The force of off-conduction position

Conduction travel: The distance from free position to conduction position

Total travel: The distance from free position to bottom position