

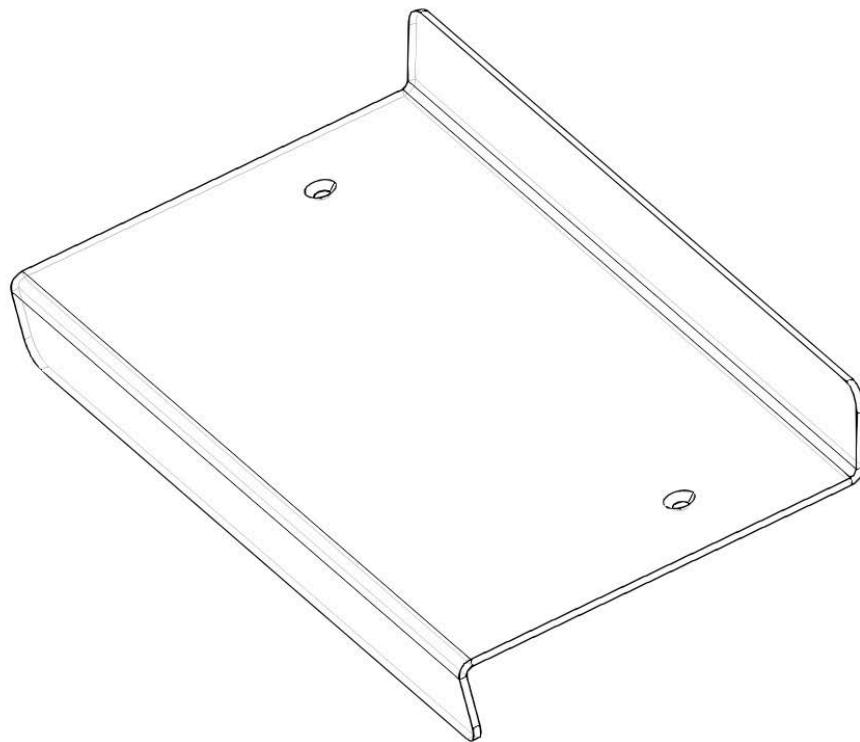

Heel Rest

Assembly Instructions



Our Support Team is here for you.

Feel free to reach out to us and we will be happy to help.



Email



Web Chat



Skype



WhatsApp



Messenger

Address : Info@allin1gaming.com



Unboxing

- Open every box first. Each group or section of the whole of a whole was seperatley packed.
- Consider placing the flattened cardboard boxes on the floor under your components to prevent them from getting scratched during assembly.
- As you discard the packaging, be careful to not accidentally throw a part away. Please recycle as much as possible.

Tips

- You can slide T-nuts in from the end of an extrusion or insert them anywhere along the length of the extrusion—no need to dismantle to insert a T-nut.
- T-nuts work similarly regardless of their orientation. No need to orient them in the same direction inside the T-slot.
- Tighten fasteners with your fingers first and leave them slightly loose until you've finished assembling a sub-section. Once you've completely assembled your machine (or a sub-assembly), tighten it all up.

Corner Brackets

Tabs on the corner brackets may need to be removed if they are perpendicular to the extrusion they are placed on. In this case they won't lie flatly on the extrusion. This can be done by placing a flathead screwdriver behind the tab and tilt upwards away from your body.

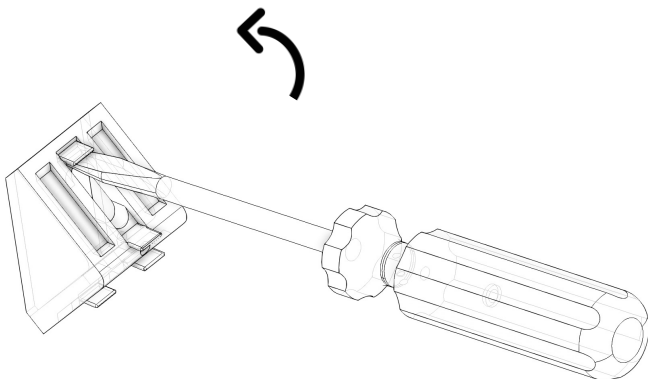

The assembly instructions will show the bottom break tab symbol on the appropriate steps where tabs need ot be broken off.





Step 2: Option 2 Add Brackets to Pedal Spreader

1

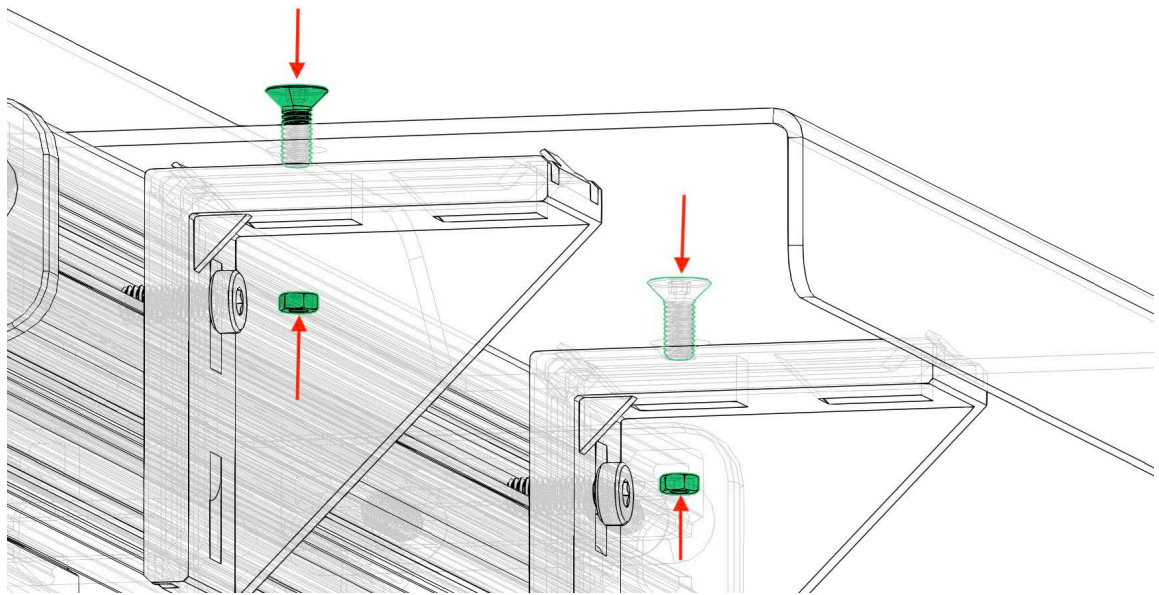
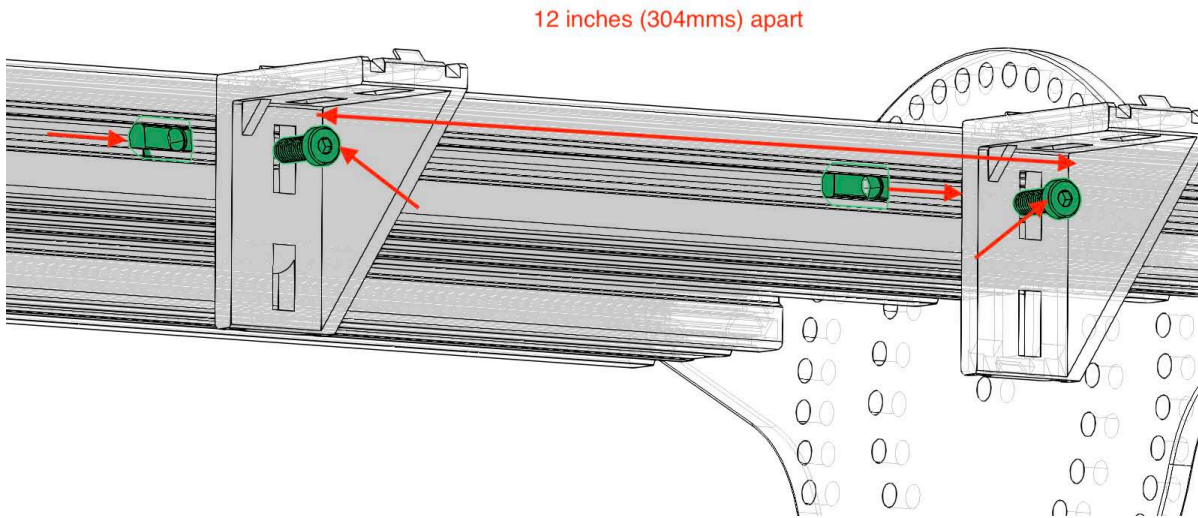

Double Corner Bracket



M8 T-Nut



M8 20mm



M6 20mm
Flat Head Bolt



M6 Nut



Step 3: Mounting Options

Can be raised or lowered

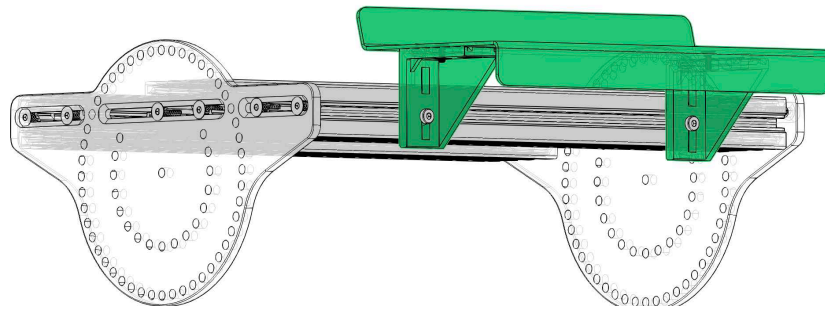
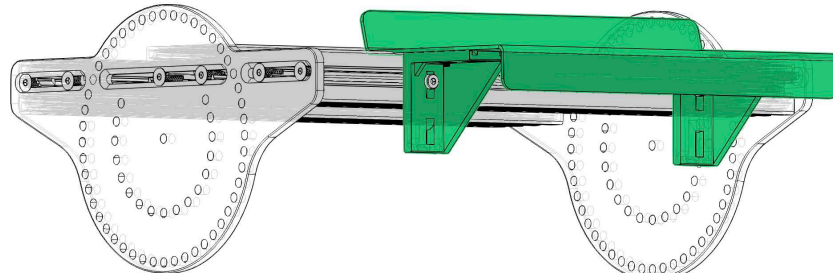

Can be pushed forward or backward

