

orison

Model: A018 tuya

USER'S MANUAL

Thank you for purchasing the ORISON | Smart Ceiling Fan

To get the best long-lasting performance, please read and follow this User's Manual carefully before operating. After reading, please store this manual in a safe place, and refer to it when needed.

SAFETY NOTES

General Precautions

It is important that you read and follow these instructions carefully and heed all warnings displayed in this manual. Please retain these instructions for future reference.



This ceiling fan must be installed by a licenced and qualified electrician in accordance with all local authority regulations.

Safety Precautions

Proceed with caution! Before installing this unit, read all instructions and safety information and review the included assembly images.

To reduce the risk of electric shock, do not install this fan in a location where it may be exposed to rain, moisture or any liquid.

When installing this unit, use a double pole disconnect switch to completely disconnect power to the unit. A double pole disconnect switch must be installed in accordance with the necessary wiring rules to completely disconnect power to the unit.

Do not attempt to operate the equipment if it is or appears to be damaged in any way, or if it malfunctions after installation.

If abnormal oscillatory movements are observed or unusual events occur (e.g., burning odor, smoke, etc.), stop using the equipment immediately and contact the manufacturer, its service agent, or an appropriately qualified person.

Do not use the product for any purpose other than the intended use described in these instructions. Avoid contact with moving fan blades and ensure that hair, clothing and other items are kept at a distance from the device. Contact with moving blades may result in serious injury.

Do not operate the unit without the blades and shade properly installed.

Do not look directly at the LED light source.

Do not install or touch the device with wet hands.

Do not place any object on the device or block the device or blade with any object.

This product is not intended for use by persons (including children) with reduced physical, sensory or mental capabilities, or by persons who lack experience and knowledge of safe operation unless they are under the supervision of a person responsible for their safety and well-being or have been instructed in the safe use of the equipment.

Close supervision is necessary when children are using this product. Do not allow children to use it as a toy.

It is normal for the motor and lights to heat up. Do not touch the equipment during or after operation.

CONTENTS

SAFETY NOTES _____ PAGE 1

INSIDE THE BOX _____ PAGE 3

INSTALLATION GUIDE _____ PAGE 4-6

Precautions

Installation Steps

HOW TO USE _____ PAGE 7-12

Product Features

Remote Guide

Tuya App Setup

Alexa Voice Control Setup

Google Home Setup

TROUBLESHOOTING _____ PAGE 13

MAINTENANCE _____ PAGE 14

WARRANTY _____ PAGE 15-16

INSIDE THE BOX

SAFETY
NOTES

INSIDE
THE BOX

INSTALLATION
GUIDE

HOW TO USE

TROUBLE
SHOOTING

MAINTENANCE

WARRANTY

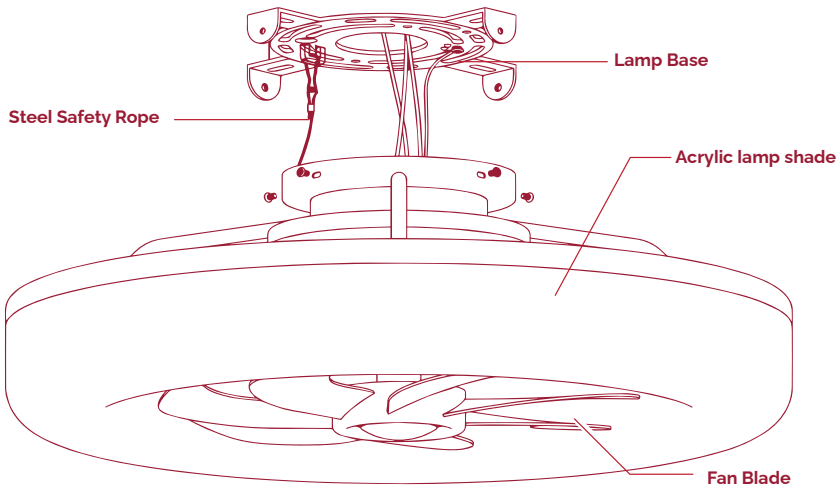

Remote Control
x 1



AAA Batteries
x2



Remote Holder Mounting Screws
x2



Base Mounting Screws
x4



Mounting Screws
x4



Anchors
x4



Wiring Caps
x3



Please note
At ORISON, we constantly strive to provide the best smart ceiling fans. Modifications and upgrades may be made. The actual product may vary slightly from the illustrations or descriptions you see in this user manual. Please refer to the actual product as the standard.

INSTALLATION GUIDE



Before installation, be sure to turn off the power supply to prevent an electric shock. During installation, this operation must be carried out in strict accordance with the provided instructions. If the installation is incorrect, it may lead to accidents such as fire, electrical shock or the lamp's body falling down.



Please entrust an electrical professional to install or repair this product. The wiring must comply with the correct electrical standards in order to avoid any danger.

Please confirm whether the voltage of your home meets the working voltage of the product before use. Using the inappropriate voltage may damage the product and cause potential safety hazards.

Electrical input guide:

110V-50/60Hz (For US/MX/CA)

220V-50/60Hz (For Asia/Europe/Australia)

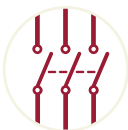

The fan remains powered on even if it is turned off via remote control or mobile app. Therefore, do not touch, replace or remove the lamp until you are sure the power supply has been cutted off, as this could result in electric shock or even death.



The light source of the lamp cannot be replaced by the user, please consult the manufacturer or its service organization for guidance. Ask someone with similar qualifications to replace the light source.



The installation height of this fan should be more than 2.3 meters from the ground.

INSTALLATION GUIDE

STEP 1 Remove base

Begin by taking your ORISON smart ceiling fan out from its packaging, and placing it on a safe surface.

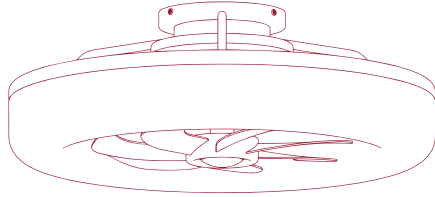

STEP 2 Base Installation

Then, fix the lamp's base onto the ceiling's mounting base with 4 screws, and confirm that the base is firmly installed. (If there isn't a mounting base on the ceiling, then please use an electric drill to drill installation holes in the ceiling, and put the expansion pipe into the installation hole).

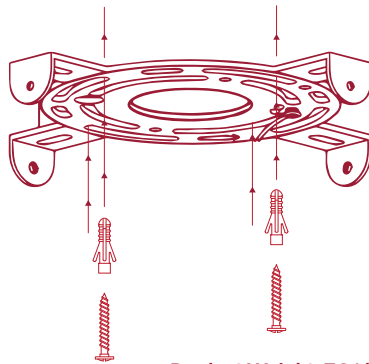

Product Weight: 7.24 lb

Accessories Required



Mounting Screws
x4



Anchors
x4

STEP 3 Buckle Safety Rope

Now buckle up the safety steel rope. This step will make wiring much easier!



INSTALLATION GUIDE

SAFETY
NOTES

INSIDE
THE BOX

INSTALLATION
GUIDE

HOW TO USE

TROUBLE
SHOOTING

MAINTENANCE

WARRANTY

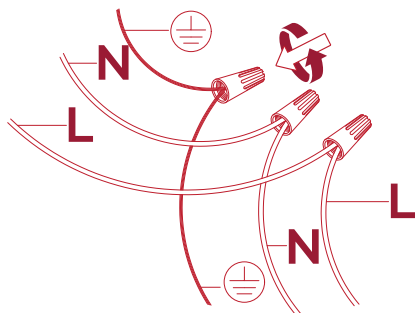

STEP 4 Wiring

Next, use wiring caps to connect the L/N/Ground wires.



Warning!
You must make sure the power is switched OFF before wiring!

Accessories Required

 Wiring Caps
x3

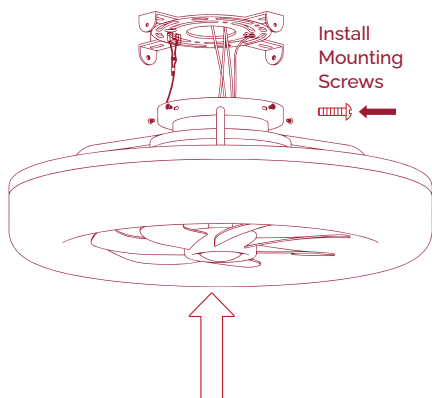

STEP 5 Install Fan

Hold the edges on both sides of the lamp's body with both hands and install the mounting screws into the side of the lamp's body, and make sure that it cannot rotate after installation.

Accessories Required

 Mounting Screws
x4

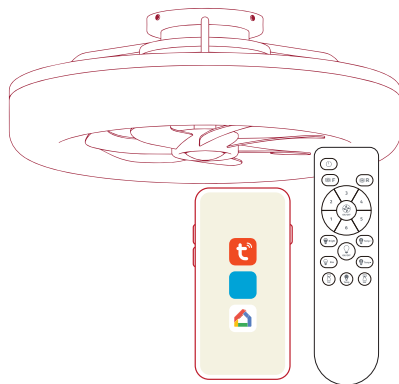

STEP 6 Testing

The installation is complete! Please switch on the power and test all the functions via the remote control and App.

Remote Control Guide: Page 8
App Setup Guide: Page 9-12

Light



Adjust
Brightness



Adjust
Light Temperature



Night Light
Mode

Fan



6-speed
Adjustment



Reversible
Fan

Smart Feature



Works with
Tuya App

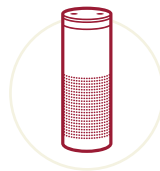

Voice Control with
Alexa, Google Home



Auto-OFF
Timer

SAFETY NOTES
INSIDE THE BOX
INSTALLATION GUIDE
HOW TO USE
TROUBLE SHOOTING
MAINTENANCE
WARRANTY

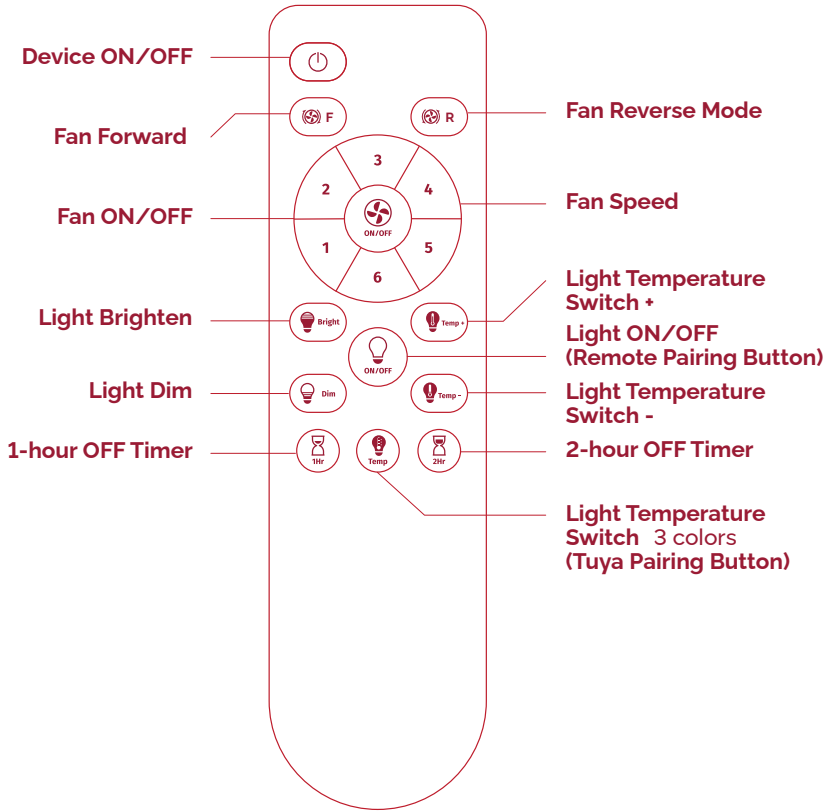

! If the remote control is not working, try re-pairing.

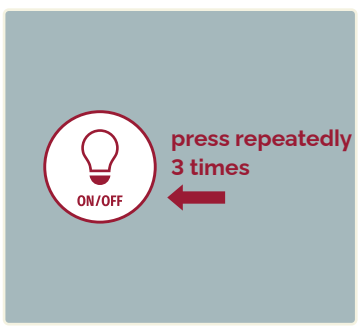

The remote control is usually pre-paired with the fan out of the box. If it doesn't work, try re-pairing it. Here's how.

Once turn the wall switch ON (within 5 seconds) then press the Light ON/OFF (light bulb with ON/OFF) button repeatedly 3 times. A flashing light indicates a successful pairing process. Now try all the buttons to check if the remote control works.

PLEASE NOTE: If the product upgrades, the upgraded function shall prevail.

STEP 1

On your phone or tablet, please download and install the latest version of the Tuya app from the app store.

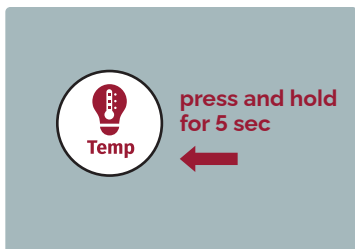

STEP 2 Enter Pairing Mode

There are two ways to enter pairing mode:

Using remote:

Press and hold the Light Temperature Switch button  for 5 seconds, when the light blinks or breathes, it indicates that the light has successfully entered pairing mode.

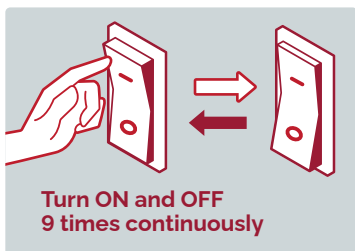

OR

Using wall switch:

Turn the wall switch ON and OFF 9 times continuously, when the light blinks or breathes, it indicates that the light has successfully entered pairing mode.

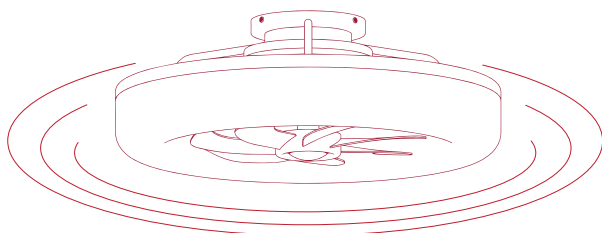

Light breathes indicates pairing mode entered successfully

STEP 3 Set up your fan with Tuya APP



Do not choose a 5G Hz Wi-Fi network at your cellphone! This will result in the connection failure to Alexa or other smart devices. Please select a 2.4G Hz Wi-Fi network. See the instructions on the next page.

*The steps may vary due to App update. Follow the App instruction to complete the setup.

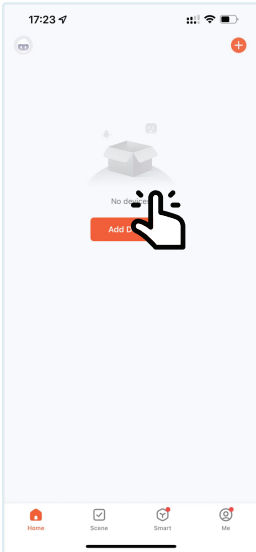

Tap 'Add Device' on home page

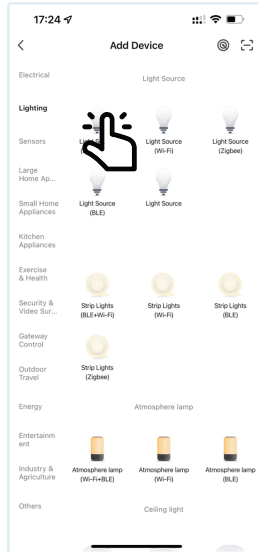

Tap to add if the device doesn't prompt out automatically

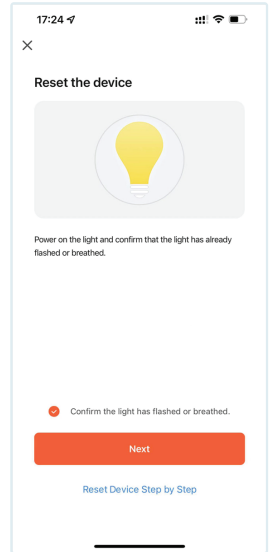

Follow the instruction

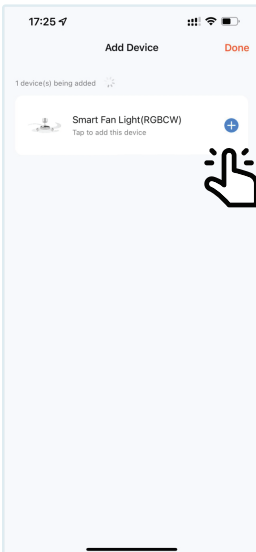

Tap '+' to add Smart Fan Light

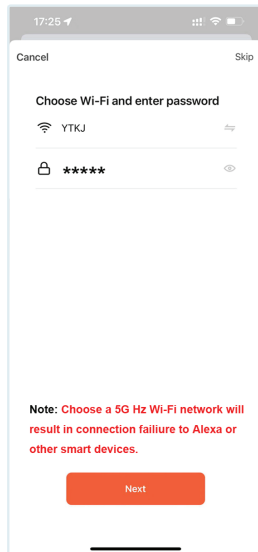

! Please choose a 2.4G Hz Wi-Fi network

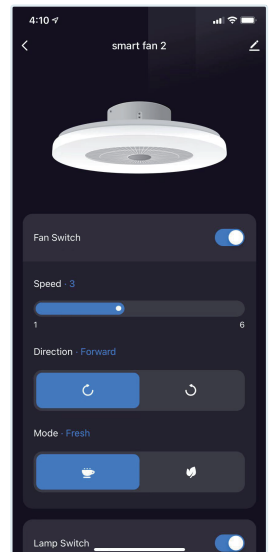

Setup completed!



The Alexa, Google Home features are **POWERED BY Tuya App**. Setup the Tuya App before proceeding the following steps.

SAFETY NOTES

INSIDE THE BOX

INSTALLATION GUIDE

HOW TO USE

TROUBLE SHOOTING

MAINTENANCE

WARRANTY

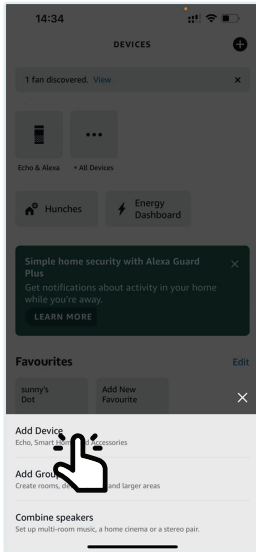

Tap 'Add Device'

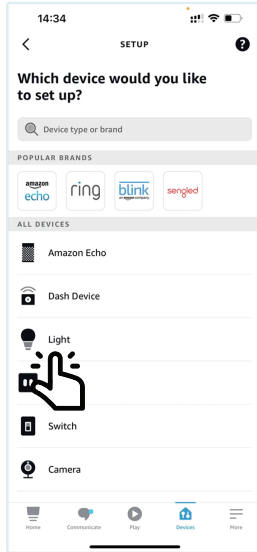

Tap 'Light'

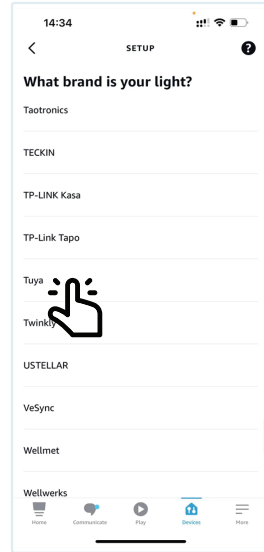

Tap 'Tuya'

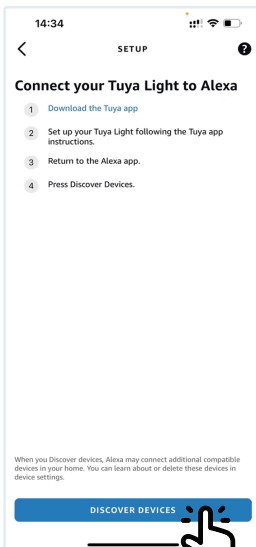

Follow the instruction

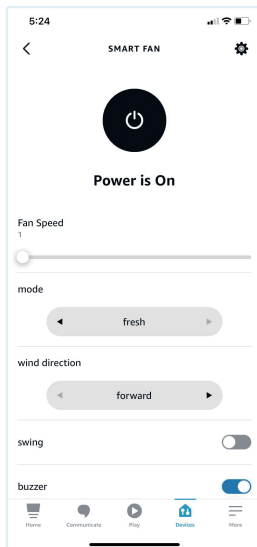

Alexa will connect 2 devices, fan and light control are in different pages

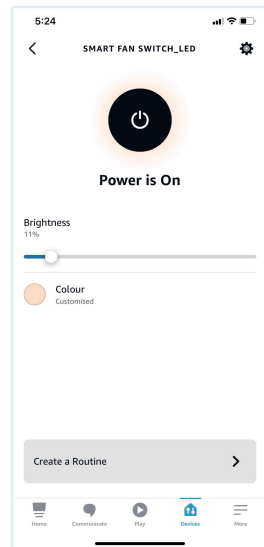

Setup completed!



The Alexa, Google Home features are POWERED BY Tuya App. Setup the Tuya App before proceeding the following steps.

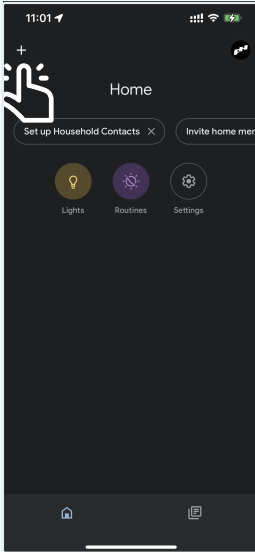

Tap '+' on home page

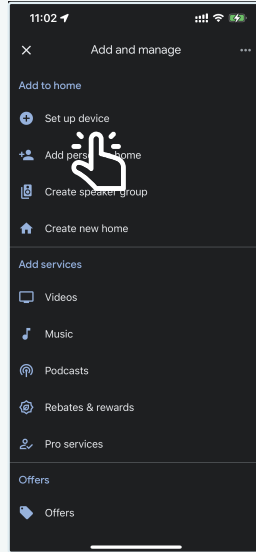

Tap 'Set up device'

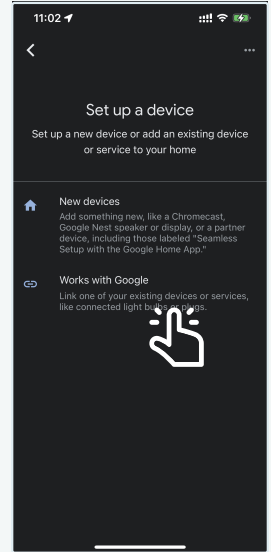

Tap 'Works with Google'

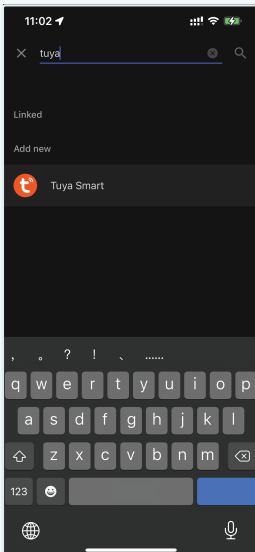

Search 'Tuya'

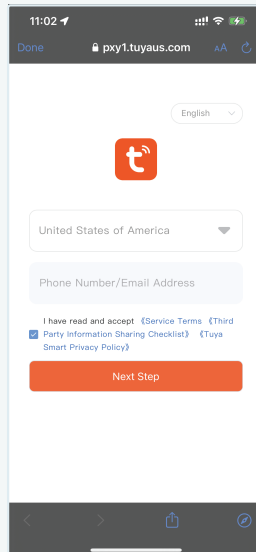

Sign in your Tuya account

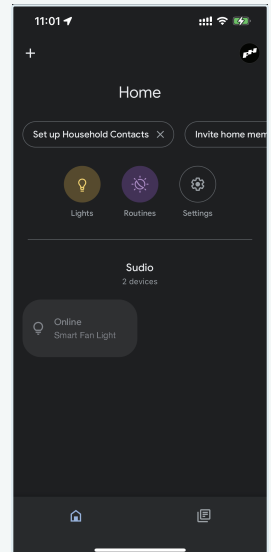

Setup completed!

SAFETY NOTES
INSIDE THE BOX
INSTALLATION GUIDE
HOW TO USE
TROUBLE SHOOTING
MAINTENANCE
WARRANTY

TROUBLESHOOTING

Check here when you think the product has malfunctioned.

PROBLEMS	POSSIBLE CAUSES AND SOLUTIONS
Fan does not operate	Has a house fuse blown or circuit breaker tripped? Please check whether the power switch is out of order.
The light is on, but the remote control doesn't work	The remote's batteries may be weak. Please change the batteries of your remote control. The remote may have lost the pairing code. Please re-pair the remote with the unit in accordance with the pairing instructions found on page 6.
The light wobbles when the fan is on	Is the light base/cross hanger loose from the ceiling? The fan's blade may be uneven, please tighten the blade to the motor.
I can not connect to the app	Are you using the latest version? Please make sure to download the latest version of the App. Has the Bluetooth function on your mobile phone been turned on?
I can not control the light	Please check whether your remote control is working correctly. Try re-pair the remote control.
I can not connect my fan to Tuya/Alexa/-google	Please make sure your cellphone has connected to a 2.4G Hz Wi-Fi network. PLEASE DO NOT CONNECT TO A 5G Hz. Wi-Fi SIGNAL!

SAFETY
NOTES

INSIDE
THE BOX

INSTALLATION
GUIDE

HOW TO USE

**TROUBLE
SHOOTING**

MAINTENANCE

WARRANTY

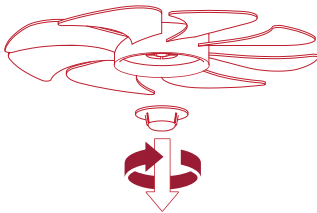
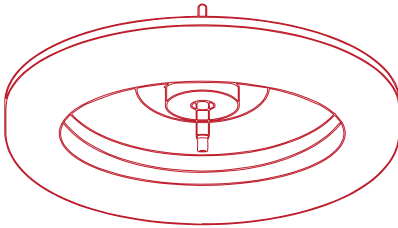

Rotate Clockwise to uninstall

1. Switch off the power.
2. Rotate clockwise to remove the fan blades' cap, and take off the blades.
3. Fan's blades can be cleaned after taking out.

Note: Do not soak the lamp's body with water directly. Once the fan lamp has been correctly cleaned, please dry it with a cloth or paper towel. To avoid the risk of falling, please confirm that the parts are installed correctly.



WARNING!

Always switch off the power prior to the cleaning in the vicinity of electrical parts! (The lamp, fan blades, etc). Wipe up any excess moisture with a cloth or paper towel to prevent any liquid from getting into any electrical parts and causing an electric shock. Please do not use any flammable or toxic cleaning liquids!

WARRANTY

Limited Lifetime Warranty

ORISON grants this limited warranty to the original purchaser of this ORISON ceiling fan for the original installation location. Thank you for choosing ORISON!

How Can Warranty Service Be Obtained?

A correct proof of purchase is required when requesting any warranty service. The original purchaser must present a sales receipt or other document that establishes proof of purchase. Orison, at its sole discretion, may accept a gift receipt. To obtain this service, you can contact us online or via email at

✉ ORISONsmarthome@gmail.com

🌐 ORISONsmarthome.com

What Does This Warranty Cover?

Motor

Limited Lifetime Warranty

If any part of your ceiling fan motor fails during your ownership of the fan due to a defect in material or workmanship, as determined solely by ORISON, ORISON will provide you with a replacement fan free of charge. *The foregoing limited warranty applies only to the motor itself and does not apply to electronic controls – such as remote control transmitters, remote control receivers, or capacitors – used in conjunction with the motor. Such electronic control items are included in the one-year limited warranty below.

Other

One-Year Limited Warranty

Except as otherwise indicated throughout this warranty, if any part of your ORISON ceiling fan fails at any time within one year of the date of purchase due to a defect in material or workmanship, as determined solely by ORISON, ORISON will provide a replacement part free of charge.*

Light Kits

Warranty May Vary

Light kits are included in the one-year limited warranty. However, you may qualify for additional warranty coverage if your fan includes the following:

LED Light Kit Modules

Three-Year Limited Warranty

If your LED light kit module or LED bulbs (not including glass components) fail at any time within three years of the date of purchase due to a defect in material or workmanship, as determined solely by ORISON, ORISON will provide a replacement free of charge.*

* If no replacement product/part can be provided for your fan within 45 days, we will provide a comparable or superior replacement product/part at the sole discretion of ORISON.

What Does This Warranty NOT Cover?

Labor Excluded. This warranty does not cover any costs or fees associated with the labor (including electrician's fees) required to install, remove, or replace a fan or any fan parts.

There is no warranty for remote control batteries; fans purchased or installed outside your country; fans owned by someone other than the original purchaser; fans for which proof of purchase has not been established; fans purchased from an unauthorized dealer; ordinary wear and tear; minor cosmetic blemishes; refurbished fans; and fans that are damaged due to any of the following: improper installation, misuse, abuse, improper care, failure to follow Orison's instructions, accidental damage caused by the fan owner or related parties, modifications to the fan, improper or incorrectly performed maintenance or repair, improper voltage supply or power surge, use of improper parts or accessories, failure to provide maintenance to the fan, or acts of God (e.g. flooding, tornadoes, etc).

THE ORIGINAL PURCHASER'S SOLE AND EXCLUSIVE REMEDY FOR A CLAIM OF ANY KIND WITH RESPECT TO THIS PRODUCT SHALL BE THE REMEDIES SET FORTH HEREIN. Orison Fan COMPANY IS NOT RESPONSIBLE FOR CONSEQUENTIAL OR INCIDENTAL DAMAGES, DUE TO PRODUCT FAILURE, WHETHER ARISING OUT OF BREACH OF WARRANTY, BREACH OF CONTRACT, OR OTHERWISE. Some places do not allow the exclusion or limitation of incidental or consequential damages, so the above limitation or exclusion may not apply to you.

ANY IMPLIED WARRANTIES OF MERCHANTABILITY OR FITNESS FOR A PARTICULAR PURPOSE APPLICABLE TO THIS PRODUCT ARE LIMITED IN DURATION TO THE PERIOD OF COVERAGE OF THE APPLICABLE LIMITED WARRANTIES SET FORTH ABOVE. Some places do not allow limitations on how long an implied warranty lasts, so the above limitation may not apply to you.

How Does State Law Affect Warranty Coverage?

This warranty gives you specific legal rights. You may also have other rights which vary from where you are.

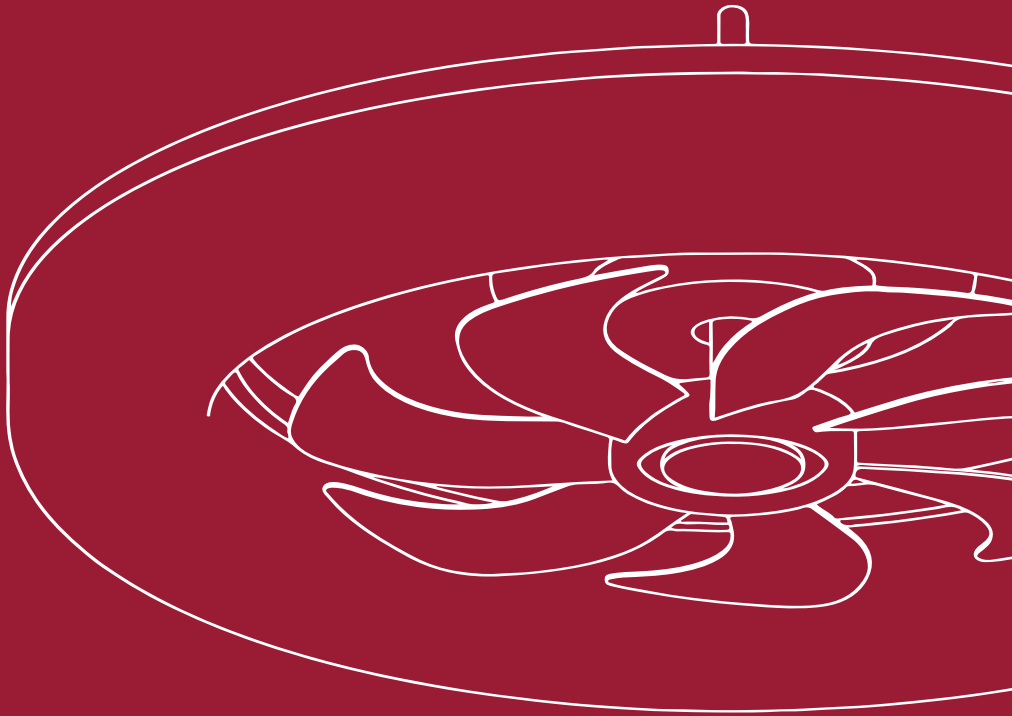

Reach out to us, it's easy!

 orisonsmarthome.com

 orisonsmarthome@gmail.com



Online service
Reply within 12 hours