

MIDI CAPTAIN

PC/CC/NOTE MIDI Foot Controller
with the original TIME ENGINE function

Ver 2.2 (May 2023)

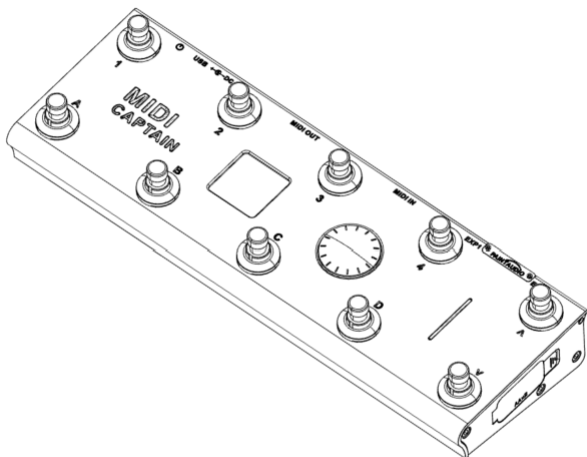

PAINTAUDIO

The manual is subject to be updated without notify
The content may not be matched to the latest firmware

1 Connection and controls

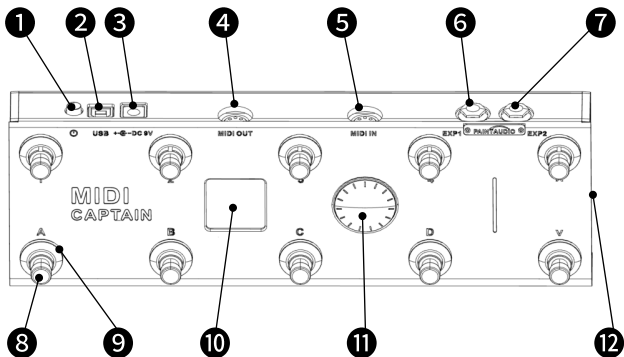

1. Power **ON/OFF** switch
2. **USB** data and **5V power** input
3. 9-12V **Auxiliary Power** input (support normal 9V pedal power. No special polarity is required though it is labeled as inner “-”)
4. **MIDI OUT**: connecting to other host's MIDI IN port
5. **MIDI IN**: receiving messages (for MIDI through)
6. **Expression** pedal input 1
7. **Expression** pedal input 2
8. **Foot switches** (x 10) labeled as 1 2 3 4 ^ A B C D V
9. **Color LED** ring (x 10) colors based on the function definition
10. 1.54 inch 240x240 24bits **color screen**
11. **Knob** with rotatory encoder and push button
12. **Battery compartment** AAx2 Ni-MH chargeable

NOTE: The device can be powered by any of the 2,3,12 ways of power sources or their combinations

Application examples: For Hardware

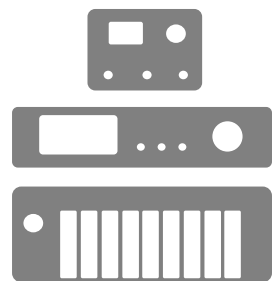

MIDI IN

MIDI OUT

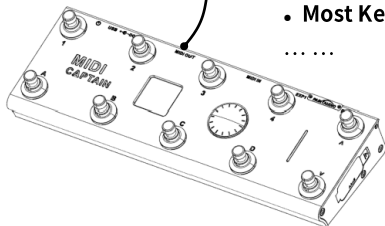

Control desktop / Rack effects pedals, keyboards, synthesizers,

- Line6 HX Stomp
- Boss GT1000Core(need convert cable)
- Fractal AXE FX2
- Fractal AXE FX3
- Fractal FM3
- Eventide H9
- Kemper Profiler Power Head
- Kemper Profiler Rack
- Hotone Ampero one Stomp
- Hotone Ampero one II Stomp
- FLAMMA FX200
- MOOER GE250
- HeadRush Gigboard
- HeadRush MX5 (need convert cable)
- LINE6 POD HD PRO X
- **Most Keyboards**

.....

Application examples: For Software

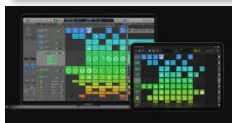
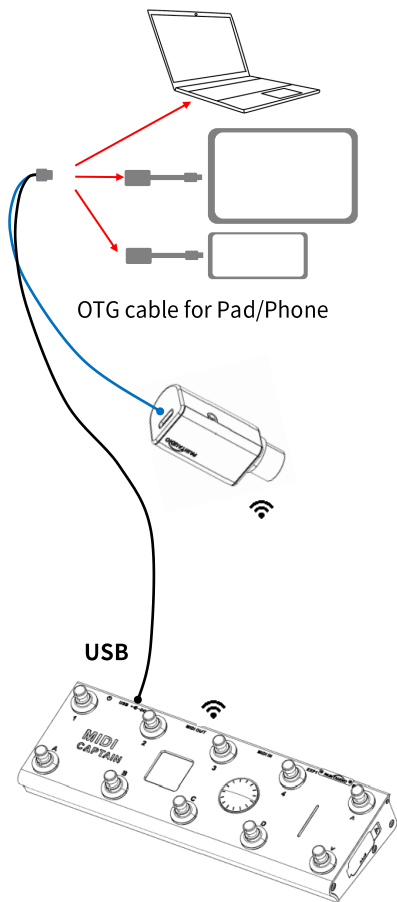

Almost works for all the music recording and effects software on PC / Pad / Phone

Application examples: Wireless Control

Using MIDI MATE wireless connection instead of MIDI cable. MIDI MATE works in 10-100m (open ground). The MAX distance is not guaranteed due to the environmental conditions. Latency on air is < 5ms.

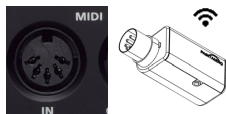

Connecting to all other host devices' MIDI IN port via the wireless dongle MIDI MATE. An optional accessory for MIDI CAPTAIN also by PaintAudio

1:1 mode

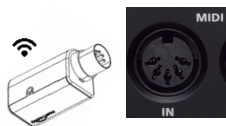
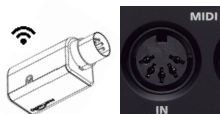
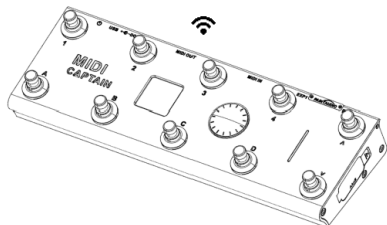

1:N mode

One MIDI CAPTAIN can pair to **N** MIDI MATEs just with the same wireless ID setup.

N could be 1 - 100 in theory. Just put all the devices in the proper distance

NOTE: MIDI MATE is not coming along with MIDI CAPTAIN and needs a separate purchase.

2 Screen display

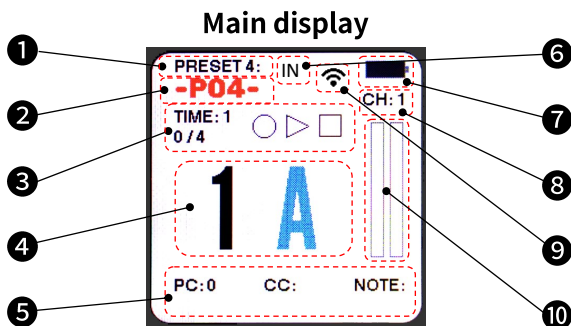

1. Device key-control functions PRESET number.
2. Preset NAME can be changed in USB deep setup mode
3. TIME ENGINE state display
4. Current PC number (host preset)
5. Indicators immediately show the sent command details
6. Immediate MIDI IN event indicator
7. Battery state indicator
8. MIDI Channel indicator
9. Immediate wireless transmission indicator
10. Immediate expression pedal position indicator

3 Basic operations

Main Page

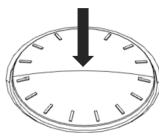
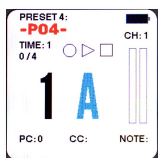

Push / Confirm

Mode Select

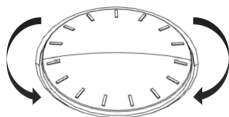
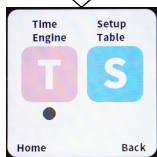

Turn / Select

Time
Engine
Setups

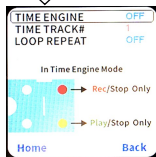

Normal
Setups

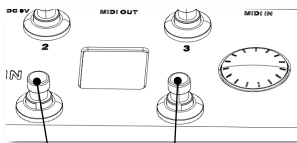

Home

Back

NOTE: When any changes are made, it takes 2 seconds before the device writes down on its internal flash memory. **⚠ Do not** power off the device during those 2 seconds period. Otherwise, the internal flash may be crashed.

4 Time engine functions

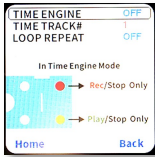

Turn on / off the Time Engine

Select the time track 1-10

ON means the time track plays in repeating when “play” is active

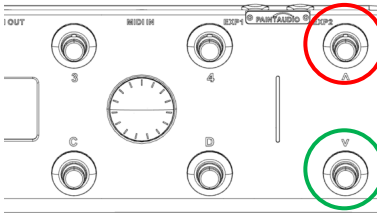

When TIME ENGINE is on

The Up/Down keys will be changed to Record (Red)/ Play (Green) functions

The key's color will be changed from white to red and green

There will be a limitation that without Up/Down keys, all the PC control range will be limited in one bank as the left 8 keys. With proper keys setup, still we can use the time engine for most songs and applications with only 8 keys.

5 Time engine example

1. Setups: TIME ENGINE:ON; TIME TRACK#:1; LOOP REPEAT:OFF
2. A backing track with the beginning beat and ready to play
3. Preparing all the needed effects presets in one bank. Stay at the first effects preset before time track recording.
4. Start the key action **recording process**:

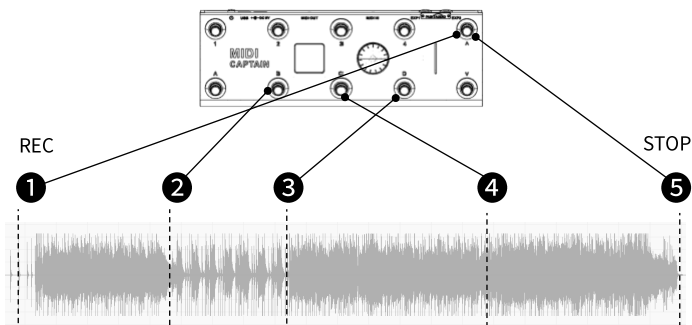

PLAY backing track

- 1 Time engine recording start
- 2 PC switching to B
- 3 PC switching to D
- 4 PC switching to C
- 5 Time engine recording STOP

An operational (better) way for the backing track beginning alignment is to use software such as Ableton live which can take the MIDI CC commands for the backing track PLAY control

5. Time engine **PLAY process**: Press the PLAY key to start

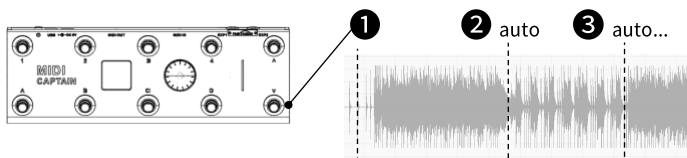

6 On-device setup items

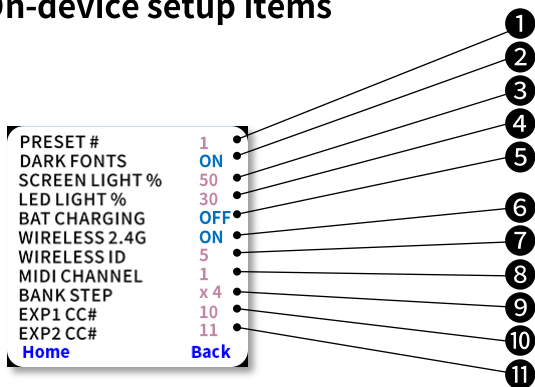

1. MIDI control preset: 1-10 (Restart to active)
2. Main page fonts color: ON (Dark) / OFF (Light)
3. Screen backlight brightness: 1-100
4. Key LED ring brightness: 1-100
5. Battery charging function ON/OFF (250mA Charging current)
6. Wireless transmission ON/OFF
7. Wireless pairing ID: 1-100 (Set the same with MIDI MATE)
8. MIDI Channel: 1-16
9. Number of presets in one bank group: x 2 3 4 5 8
10. Expression channel 1 CC ID number: 0-127
11. Expression channel 2 CC ID number: 0-127

NOTE: For item 5, battery charging is recommended OFF when using a PC/Phones/Pad power source for drawing less current. For item 4, key LED brightness is recommended at below 30% when using a battery power source.

7 USB Deep Setup mode

Besides the setups on the device itself, more setups need to be done in PC at USB Setup Mode. The device can make a virtual USB disk shown on the computer. A special power-on process is needed to enter into this mode, by pressing and holding **Key1** for about 1-2 seconds during the device powering on.

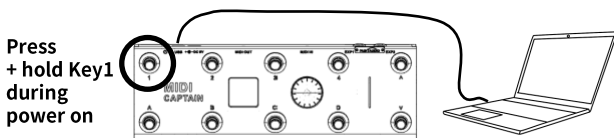

After successfully entering into USB Deep Setup mode. The device shows the picture on the left and a virtual USB disk named “MIDICAPTAIN” will show on windows PC (Ver. 8, 10, 11) or MAC OS.



Contents inside the disk:
All the deep settings are included inside the folder “setup”

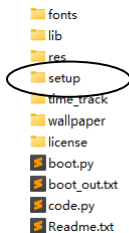

8 USB setup items

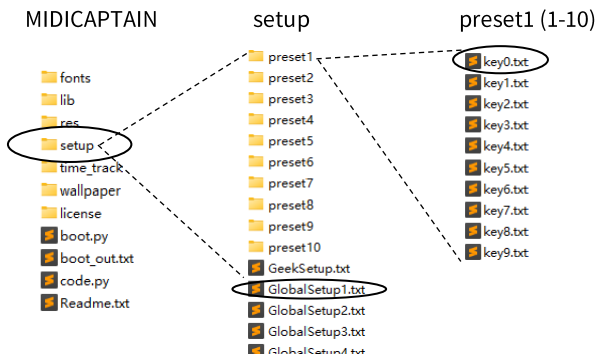

The above chart shows the USB disk folder structure. The **setup** folder includes all the settings of MIDI CAPTAIN. The **GlobalSetupN.txt** defines preset global setups including these items that can be changed on the device itself. Each **presetN (N=1-10)** folder includes all the key action setups defined by **key0.txt** to **key9.txt**.

Note: Strongly recommend copying the whole **MIDICAPTAIN** disk content and **storing** it on your PC. In case the flash-based USB disk crashes or the setup files are messed up, a copyback can restore the device to its initial state. Pay attention to the **license** folder. This folder needs carefully backup separately. It is the most important part including identification and authorization, without which the following update can't be achieved and the device may need to be returned to the factory for maintenance. If that truly happened, please contact support@paintaudio.com the first time.

GlobalSetup.txt

1	CURRENT_PRESET=	[1]	# 1-10 point to the preset folder. Need restart to be activated.....
2	DARK FONTS	= [ON]	# ON: the main screen font is dark color type. OFF: light color type.....
3	SCREEN_LIGHT	= [80]	# 1-100 Background brightness.....
4	LED_LIGHT	= [32]	# 0-100 Recommend <= 10 to save battery.....
5	BATTERY_CHARGE=	[ON]	# Turn off when connecting to mobile Host device which has less current output.....
6	WIRELESS_2.4G	= [ON]	# Turn off to save battery when not using MIDI MATE wireless receiver.....
7	WIRELESS_ID	= [8]	# 1-100 This ID should be the receiver's. Need restart to be activated.....
8	MIDI_CHANNEL	= [1]	# 1-16 Match the MIDI CHANNEL between the controller and the host device.....
9	BANK_STEP	= [4]	# 3, 4, 5, 8, 10 The number of programs change over each BANK +/-.....
10	EXP1_CC#	= [10]	# 0-127 The CC# of EXP1 pedal channel.....
11	EXP2_CC#	= [11]	# 0-127 The CC# of EXP2 pedal channel.....
12	TIME_ENGINE	= [OFF]	# Turn ON/OFF action sequence recording.....
13	TIME_TRACK	= [1]	# 1-10 Select the time recording track to be recorded in or played.....
14	LOOP_REPEAT	= [OFF]	# SINGLE or REPEAT when playing the recorded actions.....
15	WHEEL_MANUAL	= [ON]	# Turn off to avoid miss-tuning of PC number by foot touch.....
16	WALLPAPER	= [3]	# 0-20 different type of wallpaper, enjoy. Need restart to be activated.....
17	PC_NUM_START	= [0]	# 0 or 1 The program change number start from 0 or 1.....
18	MIDI_THROUGH	= [OFF]	# Turn on to forward MIDI message from MIDI IN to MIDI OUT.....
19	POWER_ON_PIC	= [1]	# 1-3 Choose the different power-on pictures which can be customized.....
20	POWER_ON_TEXT	= [MIDI CAPTAIN]	# <= 12 Chars can only be changed here in usb disk mode.....
21	WIRELESS_dB	= [6]	# Wireless power 0:12dBm 1:10dBm 2:9dBm 3:8dBm 4:6dBm 5:3dBm 6:0dBm 7:-2dBm 8:-5dBm
22			9:-10dBm 10:-15dBm 11:-20dBm 12:-25dBm 13:-30dBm 14:-25dBm

The above chart shows all the items that can be adjusted in the GlobalSetupX.txt file. We can only change the data inside the [] based on the range and function description after the # sign.

Items 1—11 are all included on the device's setting page shown in chapter 6. Items 12—14 are for the TIME ENGINE function and are shown in chapter 4. Items 15—21 are explained as follows

WHEEL_MANUAL: Turn OFF will disable the PC change function by tuning the encoder wheel. This may avoid the careless trigger of PC change.

WALLPAPER: Select the wallpaper from 0-19 inside the wallpaper folder. It may cause a fault if selected a number but no real picture inside the wallpaper folder or the picture format is not supported.

PC_NUM_START: 0-1 PC host display start from 0 or 1. In case the host device PC display is not matching the MIDI CAPTAIN display.

MIDI_THROUGH: Turn ON will let all the MIDI messages received from the MIDI IN jack of MIDI CAPTAIN route out to the MIDI OUT jack.

POWER_ON_PIC: 0-3 Change the power-on picture display.

POWER_ON_TEXT: default is MIDI CAPTAIN. Can be changed to any letter with a length < 12 Chars.

WIRELESS_dB: 0-14 change the wireless send-out power from 12dBm(0) to -25dBm(14) default at 0dBm(6)

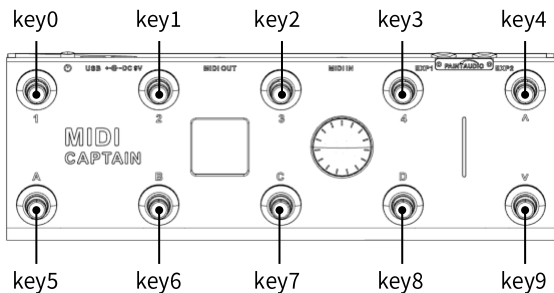

See below default mapping of the key# and the ID position

key1 (ID:0)----key2 (ID:1)----key3 (ID:2)----key4 (ID:3)----key5 (ID:4)

keyA (ID:5)----keyB (ID:6)----keyC (ID:7)----keyD (ID:8)----keyE (ID:9)

Key_ID = [0] # Quick way to change or swap key positions
 Preset_Name = [-P01-] # Any Name with length 5, this item only in this key0.txt

Settings for all press-down actions

Key_Press_Eable = [1] # 0:Disable 1:Enable
 Key_Press_MODE = [1] # 0:PC 1:CC 2:NOTE 3:UP 4:DOWN
 Key_Press_PC_MODE = [1] # 0:AUTO 1:FIXED
 Key_Press_PC_FIXED = [7] # 0-127 FIXED VALUE
 Key_Press_CC_NUMBER = [20] # 0-127
 Key_Press_CC_VALUE = [127] # 0-127
 Key_Press_CC_TOGGLE = [0] # 0:OFF 1:ON Auto toggle between SubNum and 0
 Key_Press_NOTE_NUMBER = [60] # 0-127 Please refer to the note table at the end
 Key_Press_NOTE_STRIKE = [127] # 0-127 Note loudness

Settings for all release-up actions

(For "moment" function the "Release" action must be enabled)

Key_Release_Eable = [0] # 0:Disable 1:Enable
 Key_Release_MODE = [1] # 0:PC 1:CC 2:NOTE 3:UP 4:DOWN
 Key_Release_PC_MODE = [0] # 0:AUTO 1:FIXED
 Key_Release_PC_FIXED = [8] # 0-127 FIXED VALUE
 Key_Release_CC_NUMBER = [3] # 0-127
 Key_Release_CC_VALUE = [7] # 0-127
 Key_Release_CC_TOGGLE = [1] # 0:OFF 1:ON Auto toggle between SubNum and 0
 Key_Release_NOTE_NUMBER = [61] # 0-127 Please refer to the following note table
 Key_Release_NOTE_STRIKE = [80] # 0-127 Note loudness

MIDI NOTE TABLE

Octave	C	C#	D	D#	E	F	F#	G	G#	A	A#	B
0	0	1	2	3	4	5	6	7	8	9	10	11
1	12	13	14	15	16	17	18	19	20	21	22	23
2	24	25	26	27	28	29	30	31	32	33	34	35
3	36	37	38	39	40	41	42	43	44	45	46	47
4	48	49	50	51	52	53	54	55	56	57	58	59
5	60	61	62	63	64	65	66	67	68	69	70	71
6	72	73	74	75	76	77	78	79	80	81	82	83
7	84	85	86	87	88	89	90	91	92	93	94	95
8	96	97	98	99	100	101	102	103	104	105	106	107
9	108	109	110	111	112	113	114	115	116	117	118	119
10	120	121	122	123	124	125	126	127				

key0.txt

Setup

9 Key push and release functions

```
# Settings for all press-down actions
```

```
Key_Press_Eable      = [1] # 0:Disable  1:Enable
Key_Press_MODE       = [1] # 0:PC      1:CC      2:NOTE    3:UP     4:DOWN
Key_Press_PC_MODE    = [1] # 0:AUTO   1:FIXED
Key_Press_PC_FIXED   = [7] # 0-127 FIXED VALUE
Key_Press_CC_NUMBER  = [20] # 0-127
Key_Press_CC_VALUE   = [127] # 0-127
Key_Press_CC_TOGGLE  = [0] # 0:OFF    1:ON     Auto toggle between SubNum and 0
Key_Press_NOTE_NUMBER = [60] # 0-127 Please refer to the note table at the end
Key_Press_NOTE_STRIKE = [127] # 0-127 Note loudness
```

```
# Settings for all release-up actions
```

```
# (For "moment" function the "Release" action must be enabled)
```

```
Key_Release_Eable    = [0] # 0:Disable  1:Enable
Key_Release_MODE     = [1] # 0:PC      1:CC      2:NOTE    3:UP     4:DOWN
Key_Release_PC_MODE  = [0] # 0:AUTO   1:FIXED
Key_Release_PC_FIXED = [8] # 0-127 FIXED VALUE
Key_Release_CC_NUMBER = [3] # 0-127
Key_Release_CC_VALUE = [7] # 0-127
Key_Release_CC_TOGGLE = [1] # 0:OFF    1:ON     Auto toggle between SubNum and 0
Key_Release_NOTE_NUMBER = [61] # 0-127 Please refer to the following note table
Key_Release_NOTE_STRIKE = [80] # 0-127 Note loudness
```

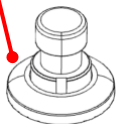

Setup for pressing down

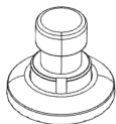

Setup for releasing up

Either the pressing down or releasing up actions can be set as **active** or **inactive**.

A **MOMENT** command is to set the pressing down CC# + 127 (or ≥ 64 for CC value), and the release up with the same CC# + 0 (CC value)

For PC commands, **AUTO** means the PC number is auto-changing based on the position A B C D, and the bank number. **FIXED** means the PC number is fixed as it has been set. The bank change will not affect it.

Note **STRIKE** number means the volume of the note. Sometimes we need to set the strike 0 at the release up a note key, otherwise the sound of the note will last and not stop.

10 Key PC/CC/Note setup examples

Example 1:

```
Key_ID = [5] # Quick way to change or swap key positions

# Settings for all press-down actions

Key_Press_Eable = [1] # 0:Disable 1:Enable
Key_Press_MODE = [0] # 0:PC 1:CC 2:NOTE 3:UP 4:DOWN
Key_Press_PC_MODE = [0] # 0:AUTO 1:FIXED
Key_Press_PC_FIXED = [7] # 0-127 FIXED VALUE
Key_Press_CC_NUMBER = [8] # 0-127
Key_Press_CC_VALUE = [3] # 0-127
Key_Press_CC_TOGGLE = [0] # 0:OFF 1:ON Auto toggle between SubNum and 0
Key_Press_NOTE_NUMBER = [60] # 0-127 Please refer to the note table at the end
Key_Press_NOTE_STRIKE = [127] # 0-127 Note loudness

# Settings for all release-up actions (For "moment" function the "Release" action mu
Key_Release_Eable = [0] # 0:Disable 1:Enable
Key_Release_MODE = [1] # 0:PC 1:CC 2:NOTE 3:UP 4:DOWN
Key_Release_PC_MODE = [0] # 0:AUTO 1:FIXED
Key_Release_PC_FIXED = [8] # 0-127 FIXED VALUE
Key_Release_CC_NUMBER = [3] # 0-127
Key_Release_CC_VALUE = [7] # 0-127
Key_Release_CC_TOGGLE = [1] # 0:OFF 1:ON Auto toggle between SubNum and 0
Key_Release_NOTE_NUMBER = [61] # 0-127 Please refer to the following note table
Key_Release_NOTE_STRIKE = [80] # 0-127 Note loudness
```

Key_ID = 5, means the key is this key is the keyA

Key_Press_Eable = 1; Key_Release_Eable = 0 means only press down have a control action

Key_Press_MODE = 0, means the key is for PC control

Key_Press_PC_MODE = 0, which means the PC number is based on the bank number and key position

Example 2:

```
Key_ID = [3] # Quick way to change or swap key positions

# Settings for all press-down actions

Key_Press_Eable = [1] # 0:Disable 1:Enable
Key_Press_MODE = [2] # 0:PC 1:CC 2:NOTE 3:UP 4:DOWN
Key_Press_PC_MODE = [1] # 0:AUTO 1:FIXED
Key_Press_PC_FIXED = [7] # 0-127 FIXED VALUE
Key_Press_CC_NUMBER = [23] # 0-127
Key_Press_CC_VALUE = [127] # 0-127
Key_Press_CC TOGGLE = [0] # 0:OFF 1:ON Auto toggle between SubNum and 0
Key_Press_NOTE_NUMBER = [C5] # 0-127 Please refer to the note table at the end
Key_Press_NOTE_STRIKE = [80] # 0-127 Note loudness

# Settings for all release-up actions (For "moment" function the "Release" action m

Key_Release_Eable = [1] # 0:Disable 1:Enable
Key_Release_MODE = [2] # 0:PC 1:CC 2:NOTE 3:UP 4:DOWN
Key_Release_PC_MODE = [0] # 0:AUTO 1:FIXED
Key_Release_PC_FIXED = [8] # 0-127 FIXED VALUE
Key_Release_CC_NUMBER = [3] # 0-127
Key_Release_CC_VALUE = [7] # 0-127
Key_Release_CC TOGGLE = [1] # 0:OFF 1:ON Auto toggle between SubNum and 0
Key_Release_NOTE_NUMBER = [C5] # 0-127 Please refer to the following note table
Key_Release_NOTE_STRIKE = [0] # 0-127 Note loudness
```

Key_ID = 3, means the key is this key is the key4

Key_Press_Eable = 1; Key_Release_Eable = 1 means both the pressing down and releasing up having control actions

Key_Press_MODE = 2; Key_Release_MODE = 2, which means the key is set for sending MIDI note messages on both key pressing and releasing

Key_Press_NOTE_NUMBER = [C5]; Key_Press_NOTE_STRIKE = 80, which means sending a C5 note message with volume 80 at the pressing down.

Key_Release_NOTE_NUMBER = [C5]; Key_Release_NOTE_STRIKE = 0, means sending a C5 note message with volume 0 (Mute) at the releasing up.

Example 3:

```
Key_ID = [2] # Quick way to change or swap key positions

# Settings for all press-down actions

Key_Press_Eable = [1] # 0:Disable 1:Enable
Key_Press_MODE = [1] # 0:PC 1:CC 2:NOTE 3:UP 4:DOWN
Key_Press_PC_MODE = [1] # 0:AUTO 1:FIXED
Key_Press_PC_FIXED = [7] # 0-127 FIXED VALUE

Key_Press_CC_NUMBER = [22] # 0-127
Key_Press_CC_VALUE = [127] # 0-127
Key_Press_CC_TOGGLE = [1] # 0:OFF 1:ON Auto toggle between SubNum and 0
Key_Press_NOTE_NUMBER = [60] # 0-127 Please refer to the note table at the end
Key_Press_NOTE_STRIKE = [127] # 0-127 Note loudness

# Settings for all release-up actions (For "moment" function the "Release" action m

Key_Release_Eable = [0] # 0:Disable 1:Enable
Key_Release_MODE = [1] # 0:PC 1:CC 2:NOTE 3:UP 4:DOWN
Key_Release_PC_MODE = [0] # 0:AUTO 1:FIXED
Key_Release_PC_FIXED = [8] # 0-127 FIXED VALUE
Key_Release_CC_NUMBER = [3] # 0-127
Key_Release_CC_VALUE = [7] # 0-127
Key_Release_CC_TOGGLE = [1] # 0:OFF 1:ON Auto toggle between SubNum and 0
Key_Release_NOTE_NUMBER = [61] # 0-127 Please refer to the following note table
Key_Release_NOTE_STRIKE = [80] # 0-127 Note loudness
```

Key_ID = 2, means the key is this key is the key3

Key_Press_Eable = 1; Key_Release_Eable = 0 means only pressing down having control actions

Key_Press_MODE = 1, means the key is set for sending MIDI CC message on a key pressing moment

Key_Press_CC_NUMBER = [22]; Key_Press_CC_VALUE = [127], means the CC message is (22, 127).

Key_Press_CC_TOGGLE = [1], which means toggling enabled. In this case, every time pressing down the key. The CC message value will be auto-toggling as (22, **127**), (22, **0**), (22, **127**), (22, **0**) and so on.

11 Factory presets

The factory presets is designed to match the most popular host hardware, software, APPs, and applications. Note that the name of PRESET does have to be matched with the host hardware or software in use. The tables layout below are matching the key positions of the device.

The color led of the keys are assigned as **CYAN** for PC, **PURPLE** for CC, **YELLOW** for NOTE, and **WHITE** for bank up and down.

PRESET1 JAMP

CC 21	CC 22	CC 23	CC 24	UP
PC auto	PC auto	PC auto	PC auto	DOWN

PRESET2 BIAS

CC 80 toggle	CC 81 toggle	CC 82 toggle	CC 83 toggle	UP
PC auto	PC auto	PC auto	PC auto	DOWN

PRESET3 AXFX

CC 15 Tuner	CC 49 Drive1	CC 47 Delay1	CC 83 Reverb1	UP
PC auto	PC auto	PC auto	PC auto	DOWN

NOTE: The factory preset Setup package may be changed without notifying

PRESET4 KMPA (For KPA)

CC 31	CC 17	CC 26	PC auto	UP
PC auto A	PC auto B	PC auto C	PC auto D	DOWN

PRESET5 PC3AM (For Amphero serials)

CC 49 Tog	CC 51 Tog	CC 53 Tog	CC 60 Tog	UP PC Bank 3x
PC auto	PC auto	PC auto	CC 76 Tap	DOWN PC Bank 3x

PRESET6 PC8 (For general PC control)

PC auto	PC auto	PC auto	PC auto	UP
PC auto	PC auto	PC auto	PC auto	DOWN

PRESET7 ALLCC (For general CC control)

CC 20	CC 21	CC 22	CC 23	CC24
CC 80	CC 81	CC 82	CC 83	CC84

NOTE: The factory preset Setup package may be changed without notice

PRESET8 ALLNT (For general Note sent)

Note C5	Note D5	Note D#5	Note E5	Note F5
Note G5	Note A5	Note A#5	Note B5	Note C6

PRESET9 AxeSN (For FM3, need to turn on scene control CC 34)

CC15 Tog Tuner	CC47 Tog Stomp	CC83 Tog Delay	CC14 127 Tap	PC +1
CC34 0 Scene 0	CC34 1 Scene 1	CC34 2 Scene 2	CC14 127 Tap	PC -1

PRESET10 Quadx (For Qual Cortex DSP)

CC 43 0 A	CC 43 1 B	CC 43 2 C	CC 43 3 D	CC45 Tog Tuner
CC 43 4 E	CC 43 5 F	CC 43 6 G	CC 43 7 H	CC44 127 Tap

NOTE: The factory preset Setup package may be changed without notice

12 Backup and restore

It is recommended to back up the whole MIDICAPTAIN disk on your PC the first time enter the USB deep setup mode. The disk includes the following contents. The most important folder is the **license** folder. We can download further update and the whole MIDICAPTAIN folder on **www.paintaudio.com** except the license folder which is subject to the unique device on your hand.

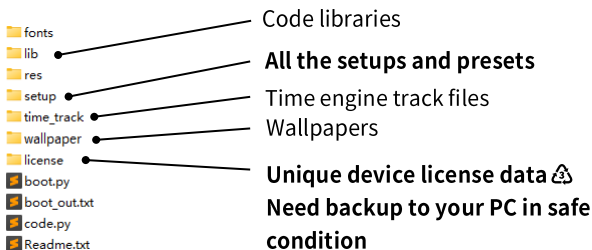

The device is subject to continuous updating and increasing functions and abilities. All the updates will be published on **www.paintaudio.com**. we can download further update packages and update the device at any time.

Fully disk update:

- Download MIDICAPTAIN full package and unzip the folder
- Holding key1 and power on the device with a PC-USB connection. (Windows PC is the first choice)
- Find the MIDICAPTAIN disk and delete all files and folders **except the license folder**
- Copy/Paste the updating folders and files into the disk and restart. The whole paste process may take about 5-10min. Restart the device at normal

Presets only update:

- Download/modify the setup folder only. Do all the setup changes at once before copy into the device
- Copy / Paste the **setup folder** directly into the MIDICAPTAIN disk and overwrite the existing fold and files (backup ahead). Taking about 0.5min. Restart the device at normal

13 Firmware 3.0 brief

The firmware 3.0x version is released on Mar. 2023.

You can find and download the updating package on

www.paintaudio.com

FW3.0 is a combination of the **Normal MODE** and the **Geek MODE**.

Pressing and hold key2 when power on will lead to the Geek MODE

Pressing and hold key3 when power on will go to the Geek MODE with all LEDs on.

Pressing and hold keyA when power on will lead to the Normal MODE

The MODE state is remembered and no need to do Holding-On every time.

For the **Normal MODE 3.0**, there are several improved functions as below.

In the KeyX.txt setup files, the follow configuration items are added.

Key_Color_Overwrite = [0] # 0:Disable 1:Enable

This item defines whether to use a customer assigned LED color for current button.

Key_Color_User = [0x00FF00]

This item defines the user assigned LED color. The RGB color index is in HEX format as **0xFFFFFF**.

Here are some color index example:

Red	0xFF0000
Cyan / Aqua	0x00FFFF
tomato	0xFF6347
lime green	0x32CD32
deep sky blue	0x00BFFF

Key_Press_CC_SCENE = [0] # 0: OFF 1:ON Control the LED work as scene control

If this item is set to 1(ON), it means the LED will action for a Scene control.

This is only effective when the key is set to MIDI CC function. In Scene control mode, the current pressed button will be lighted on, other buttons with this 1(ON) setting will be off.

For the **Geek MIDE 3.0**, please refer to the following video for the operation guide. https://youtu.be/294lZ_s1Cgc

14 Wallpaper setup

The wallpaper of the device can be changed in USB deep setup mode. In the wallpaper folder, we can find all the available wallpapers named wpX.bmp. We can choose the X number inside the GlobalSetup.txt file of the WALLPAPER item with the range from 0 to 19.

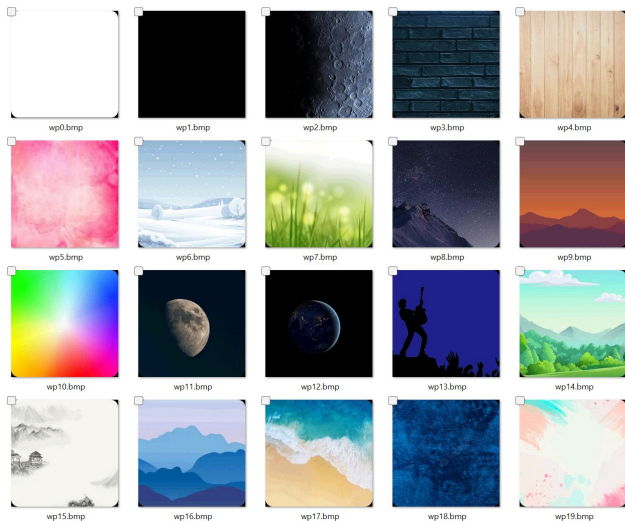

We can make our wallpaper picture, and rename and replace the one in the wallpaper folder. The format of the wallpaper has to be matched with the following parameters.

- 240x240 pixel
- Windows 24bit RGB888 color format
- 17-pixel black round corner (optional and recommended to match the device screen window)

NOTE: The factory wallpaper package may be changed without notifying

15 Other tips

If the battery is the only power source, to last the battery life, the screen, and color LED lightness will be dropped by about 50%. The key actions can be customized to meet special application requirements such as sending multi-commands at one time pressing or releasing, sending special MIDI commands other than PC/CC/Note, sending keyboard HID commands, etc. We will publish variable kinds of firmware packages which can be loaded into the MIDICAPTAIN disk easily. Also, it is possible that you can contact **contact@paintaudio.com** for special requirement applications. For simple modification, we could provide firmware customization to support.

Besides using MIDIMATE 2.4G wireless dongle, it is possible to connect to mobile devices via Bluetooth with the help of Bluetooth MIDI dongle such as the WIDI Master from <https://www.cme-pro.com/widi-master/> MIDICAPTAIN has a special design to support the use of letting the MIDI jack as the power source of external dongles such as the WIDI Master.

Please attention: PaintAudio is not responsible for injury or loss caused by using other devices/accessories.

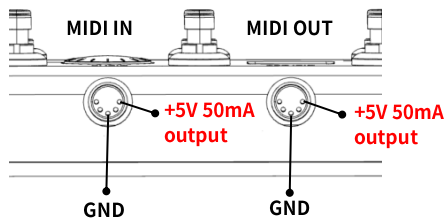

16 Specification

Power Voltage	5V(USB); 9V-12V(Adapter)
Power Current	0.1A - 0.4A (LED full brightness)
Power	0.5W - 5W (LED full brightness)
Foot switches	10, Fully customizable
Presets	10, Fully customizable
Screen	240x240 RGB 24bits LCD
Battery	AA x2, Ni-MH or LR6, 6-12 hours using
Battery charging	250mA auto-charging
Wireless	2.4G 100 pair channels
MIDI	IN and OUT with 5V power output
CPU	120MHz dual core
Flash memory	8M bits
EXP IN	2 Channel
Weight	0.75 kg without package
Dimension	283mm x 90mm x 55mm

17 Safety information

Always follow the basic precautions listed below to avoid the possibility of serious injury or even death from electrical shock, damages, fire or other hazards. These precautions include, but are not limited to, the following:

- Do not connect the instrument during a thunder.
- Do not set up the cord or outlet to a humid place, unless the outlet is specially designed for humid places.
- If the instrument needs to be powered by AC, do not touch the bare part of the cord or the connector, when the power cord is connected to the AC outlet.
- Always follow the instructions carefully when setting up the instrument.
- Do not expose the instrument to rain or moisture, to avoid fire and/or electrical shock.
- Keep the instrument away from electrical interface sources, such as fluorescent light and electrical motors.
- Keep the instrument away from dust, heat, and vibration.
- Do not expose the instrument to sunlight.
- Do not place heavy objects on the instrument; do not place containers with liquid on the instrument.
- Do not touch the connectors with wet hands.
- Caution to the sharp edges and corners of the metal box. Leave the device out of the reach of kids and children when no guardian.
- Take off the batteries when not using the device for more than 3 days.
- Remove the USB cable or adapter powering source when not using the device.

18 Contact Us

Email: contact@paintaudio.com

Web: www.paintaudio.com

19 Other Statements

This User Guide is only used as a reference for the product. Any use not specified in the User Guide is considered to be the wrong use of the product. PaintAudio assumes no responsibility for any loss resulting from irregular use. This User Guide may contain name and pattern information of other products, and the reference is used as auxiliary instructions. The owner of the registered trademark or patent can apply to change or delete the use of the trademark or patent. PaintAudio owns the right to modify this User Guide on account of product upgrades.

保修卡 Warranty

型号 Model	
用户签名 Signature	
日期 Date of Sales	
地址 Address	
序列号 SN	
经销商 Distributor	
发票号 Invoice No.	
其它备注 Others	

本产品自购买之日12个月内享受免费维保服务。以下情形除外: 不可抗力损坏; 人为损坏; 私自拆修; 法规约定的其它情形。

This product enjoys free maintenance service within 12 months from the date of purchase. Except for the following situations: force majeure damage; man-made damage; unauthorized dismantling and repair; other circumstances stipulated by laws and regulations.

PAINTAUDIO



合 格 证
QUALIFICATION

型号 MODEL	
检验 CHECKER	
日期 DATE	

 PAINTAUDIO

THANK YOU