

STAR 36" | 42" | 48"

INSERT



FEATURED HIGHLIGHTS

POWERFUL & QUIET 4-SPEED BLOWER

Remove smoke effectively.

LIFETIME MOTOR WARRANTY

Guaranteed to keep your kitchen fresh.

DIMMABLE LED ILLUMINATION

Never miss a moment.

EASY TO INSTALL

With industry-leading instructions.

TECHNICAL SPECIFICATIONS

Body: Stainless Steel (304) (1mm)

Power Rating: 120 V / 60 Hz (USA & Canada standard)

General Input Power: 240 W + (# of Lights x 5W)

Motor Input Power: 240 W (120W + 120W)

Motor Revolution: 800 RPM to 1300 RPM ($\pm 10\%$)

Levels Of Speed Control: 4 Levels

Maximum Airflow: 900 CFM

Noise Level (Min/Max): 1.0 Sones / 6.5 Sones

Weight: 65 lbs. - Increase by 10 lbs. every size up

CONTROLS

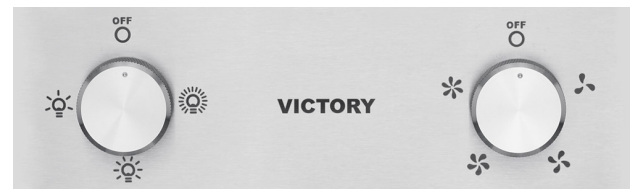

DIMENSIONS

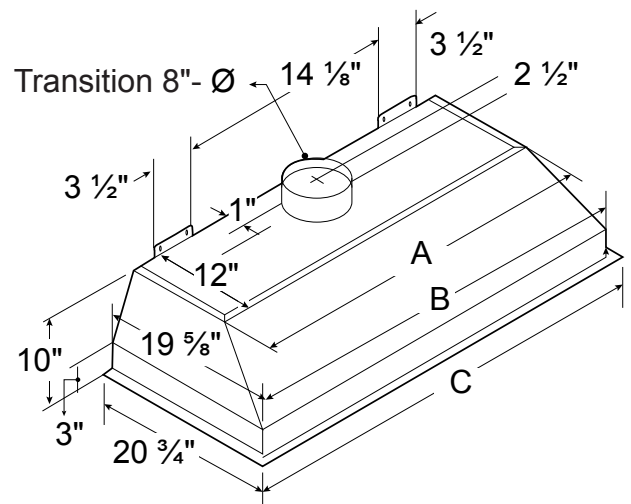

	36"	42"	48"
A	27 1/2"	33 1/2"	39 1/2"
B	33"	39"	45"
C	35 3/16"	41 3/16"	47 3/16"

VENTILATION DETAILS

Duct Direction: Top Exhaust

Filtration Type: Stainless Steel Filters + Grease Trap

Duct Type: 8" Round

Dishwasher-safe: Yes

Light Type: LED

Controls: Mechanical Switches with Hidden Design

CERTIFICATIONS

cETLus

WARRANTY

5 Year Parts