

AIRSTAR[®]

DENTAL AIR SYSTEM

Installation and Operation Manual



AIR
TECHNIQUES equipped for life[®]



TABLE OF CONTENTS

SECTION	PAGE
Congratulations	4
Safety Instructions	5
Key Parts Identification	6
Sizing Guide	7
Operating Information	7
Site Requirements	8
Installation Information	10
Troubleshooting	15
Maintenance	17
Replacement Parts	20
Optional Accessories	20
Product Specifications	21
Warranty	22
On-Line Warranty Registration	22

LIST OF ILLUSTRATIONS

FIGURE	TITLE	PAGE
1	AirStar Parts Location	6
2	Overall Site Requirements	9
3	Left and Right Head Assembly Installation	10
4	Left and Right Head Assembly Motor Connections	11
5	AirStar Electrical Connections	13
6	Moisture Monitor and 5 Micron Filter Location	17
7	AirStar Filter Location.	18
8	Service Timer	19

CONGRATULATIONS

Your **AIRSTAR** generates 100% oil-less, ultra-dry dental air which protects valuable hand-pieces from premature failure due to the effects of moist air and the build-up of oil residue. Because no oil is used for mechanical lubrication, there is no chance of introducing an oily film to a prepared surface which could compromise resin retention and restorations, wasting chair time. Most important, your patients's health is protected with ultra-dry air that provides an environment that is not conducive to bacterial growth.

The **AIRSTAR** utilizes a long stroke, small bore piston to compress the air. This piston is bonded with an anti-friction polymer to eliminate the need for oil. The air is forced through the Membrane Dryer System consisting of the cooler and the membrane. This system removes moisture and air impurities providing the driest possible compressed air while maximizing performance. This 100% ultra-dry air is reserved in the main storage tank for use by the operatory air system. The **AIRSTAR** features include:

- Virtually Maintenance Free
- Low Pressure Dew Point
- Uninterrupted Compressor Availability
- Maximum Dryness with Quadruple Filtered Air
- Compact size for space-saving installation

Since 1971, when Air Techniques pioneered the manufacture of oil-less air for dentistry, thousands of dentists have depended on their **AIRSTAR**. Now that your practice has an **AIRSTAR**, you, too, can depend on the delivery of 100% oil-less, ultra-dry air and efficient, trouble-free operation.

SAFETY INSTRUCTIONS

Use of the **AIRSTAR** not in conformance with the instructions specified in this manual may result in permanent failure of the unit.

WARNING: To prevent fire or electrical shock, do not expose this appliance to rain in or moisture.

All user serviceable items are described in the maintenance section.

Manufacturing date code on serial number label is in the format Month YYYY.

ATTENTION USERS:



Alerts users to important Operating and Maintenance instructions. Read carefully to avoid any problems.



Warns users that uninsulated voltage within the unit may be of sufficient magnitude to cause electric shock.

I ON
O OFF

Indicates the ON and OFF position for the Equipment power switch.



Indicates that the equipment complies with the Medical Device Directive 93/42/EEC.



Air Techniques, Inc.
1295 Walt Whitman Road
Melville, New York, USA 11747- 3062



MEDICAL ELECTRICAL EQUIPMENT

WITH RESPECT TO ELECTRICAL SHOCK, FIRE, MECHANICAL AND OTHER SPECIFIED HAZARDS ONLY
IN ACCORDANCE WITH UL-60601-1, CAN/CSA C22.2 NO.601.1
66CA

All **AirStar** compressors comply with NFPA 99C level 3 requirements



Indicates protective Earth Ground for the Equipment power switch.



Medical Device Safety Service
Schiffgraben 41
30175 Hannover, Germany

KEY PARTS IDENTIFICATION

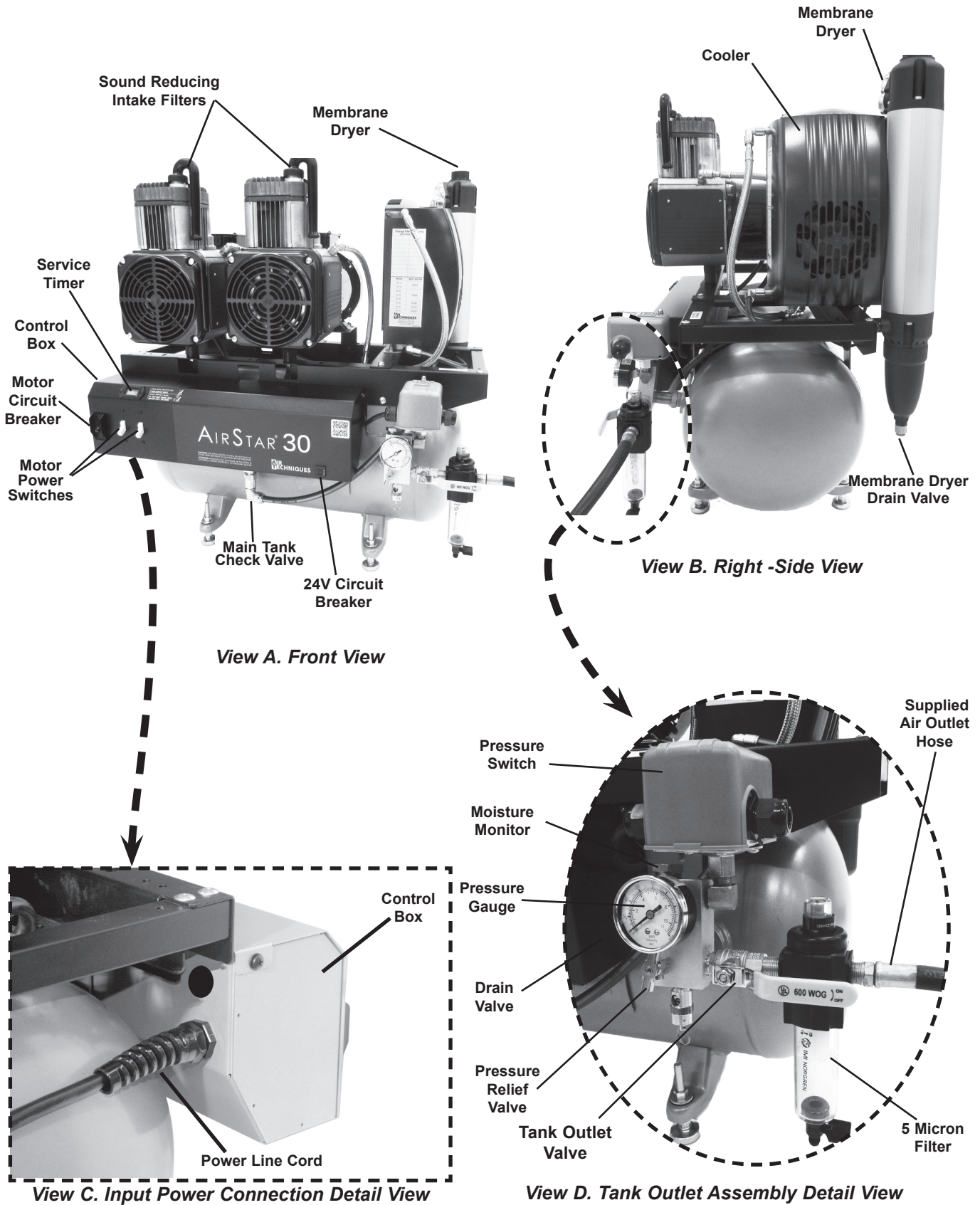

Figure 1. AirStar Parts Location

SIZING GUIDE

Choosing the correct size **AIRSTAR** for your practice depends on the number of air users and the anticipated air demand. To assure optimum compressor operation, the air demands should not exceed the number of air handpiece users shown in the chart below:

Model	Recommended Number of Users	Number of Heads	Number of Motors
AS10	1 - 2	1	1
AS12	1 - 2	1	1
AS21	2 - 3	2	1
AS22	2 - 3	2	1
AS30	3 - 4	2	2
AS40	4 - 5	3	2
AS50	5 - 7	4	2
AS70	7 - 10	6	3
AS100	10-14	8	2

OPERATING INFORMATION

■ **AS10, AS12, AS21 and AS22**

- If a remote Control Panel is being used, the circuit breaker on the face of the compressor Control box must be in the ON position.
- The 24 volt circuit breaker must also be in the ON position. Make sure the reset button is flush with the face of the circuit breaker. If it isn't, push it in to reset.
- If a Remote Control Panel is not being used, be sure that the yellow and the orange wires are connected to one another. These wires are located in the pressure switch. The circuit breaker located on the face of the compressor Control Box is the power control for the motor.

■ **AS30, AS40, AS50, AS70 and AS100**

- If a Remote Control Panel is being used, ALL switches on the face of the compressor Control Box must be in the ON position.
- If a Remote Control Panel is not being used, be sure that the yellow and the orange wires are connected to one another. These wires are located on the pressure switch. The power switches located on the face of the compressor Control Box are the power control for each motor.

Note: Compressor motors are designed to run together. Do not run one head at a time unless one head has failed and you are waiting for service.

- The motor circuit breaker must be kept in the ON position and should not be used as a switch.

SITE REQUIREMENTS

Service Clearance:

- Allow 12" on all sides for all models.

Ambient Temperature:

- Must not exceed 105°F

Air System Plumbing Connection:

- 3/8" F.N.P.T. Shut-off valve and a 6 ft. pressure hose (supplied)
- Air distribution piping for all models - 1/2", type "L" or type "K" copper
- If pipe volume is too great, more than 235 in³ or more than 100 ft. of 1/2" diameter pipe, a pressure regulator should be installed between the main tank and the distribution piping. Set pressure to pressure switch cut in value (factory set at 85 PSI).

Environmental:

Operating

- Indoor use at altitudes up to 2000m. Temperature 5 to 40°C (41 to 105°F).
- Maximum relative humidity 80% for temperatures up to 31°C, decreasing linearly to 50% relative humidity at 40°C.
- Supply voltage fluctuation of +/- 10% of nominal voltage.

Storage and Transport:

- Temperature, -18 to 65°C (0 to 150°F).
- Relative Humidity, 0 to 90%.

IEC 60601-1 Classification:

- | | |
|--|--|
| ■ Protection against electric shock (5.1, 5.2): | Class I |
| ■ Applied Parts: | There are no Applied Parts. |
| ■ Protection against harmful ingress of water (5.3): | Ordinary, IPXO |
| ■ Degree of safety in the presence of flammable anesthetics mixture with air or with oxygen or with nitrous oxide (5.5): | Not suitable. |
| ■ Mode of operation (5.6): | |
| - All Modes Except AS100: | Continuous |
| - AS100 Only: | 50% Duty Cycle; Maximum Continuous ON Time of 20 Min |

SITE REQUIREMENTS

Site Electrical Requirements

AirStar Model	AS10	AS12	AS21	AS22	AS30	AS40	AS50	AS70	AS100
Requirement									
Nominal Supply Voltage (VAC, see note)	120	220	120	220	220	220	220	220	220
Frequency (Hz)	60	60	60	60	60	60	60	60	60
Full Load Amps	8	4	15	8	8	12	16	24	20
Minimum Panel Breaker Rating (Amps)	20	10	30	20	20	20	30	40	30
Minimum. Wire Size (AWG)	12	16	10	12	12	12	10	8	10

Note: Install a buck or boost transformer if actual facility service is above or below the supply voltage fluctuation of $\pm 10\%$ of nominal voltage ratings listed.

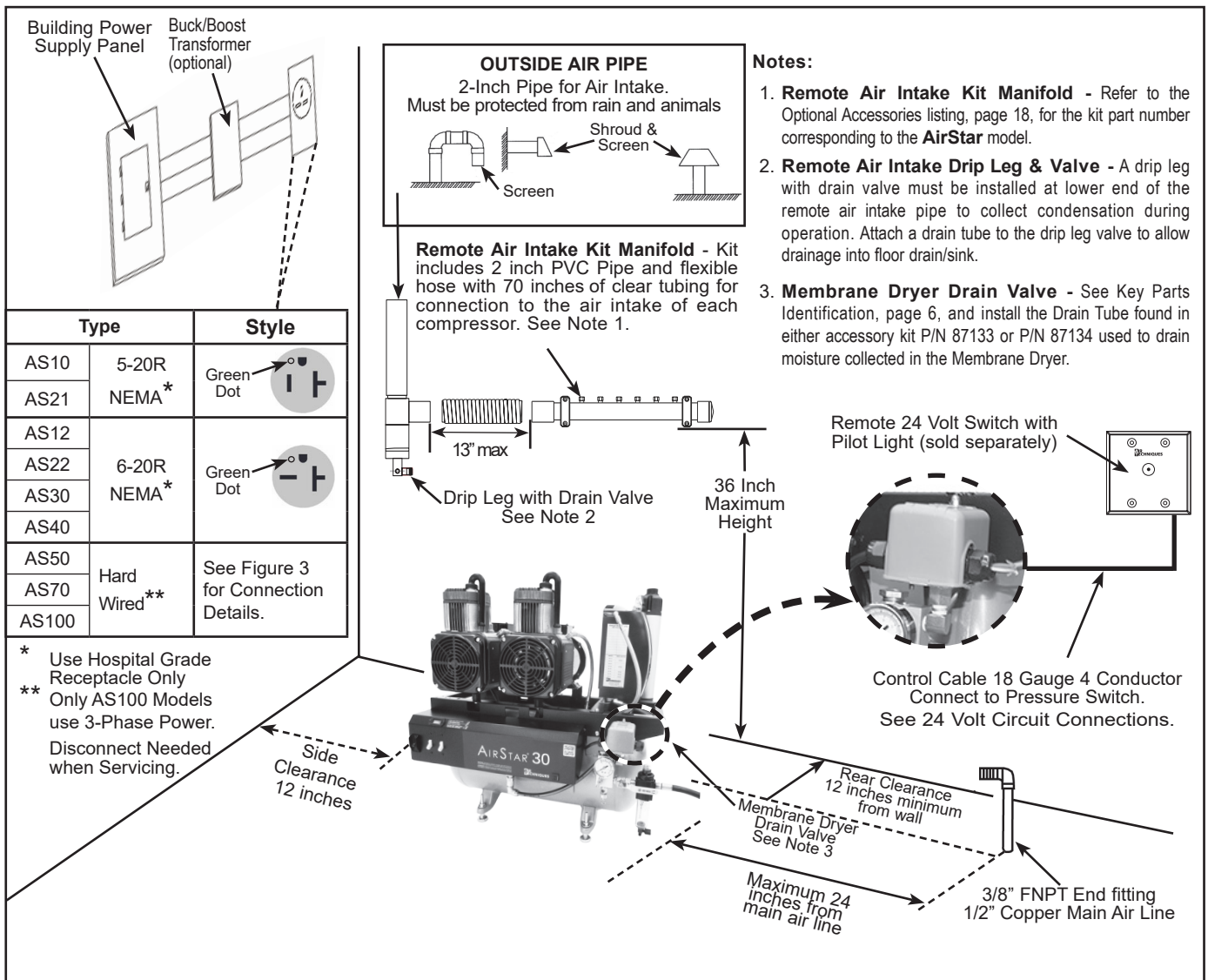

Figure 2. Overall Site Requirements

INSTALLATION INFORMATION



Each assembly (tank and heads) weighs over 100 pounds and requires two people to lift.

AS100 ASSEMBLED at the SITE

Installing Left and Right Head Assemblies

All AIRSTAR models, except the AS100, are shipped assembled and can be installed upon delivery by following the installation guidelines for plumbing and electrical connections provided by pages 12 & 13. The AS100 is shipped as separate assemblies that must be assembled during installing the system at the site

Place the tank assembly in the installation space; then perform the following procedure to install the left and right head assemblies onto the AS100 tank assembly.

- Left head installation.
 - Move air hose A and B to make sure they are not damaged during installation.
 - Orient the left head with its electrical box on the right side.
 - Align the 4 screw holes of the mounting plate with the 4 left shock mounts.
 - Install the head assembly onto the 4 left shock mounts and secure with 4 nuts provided with the head assembly accessory kit.
- Right head installation.
 - Move air hose A and B to make sure they are not damaged during installation.
 - Orient the right head with its electrical box on the left side.
 - Align the 4 screw holes of the mounting plate with the 4 right shock mounts.
 - Install the head assembly onto the 4 right shock mounts and secure with 4 nuts provided with the head assembly accessory kit.

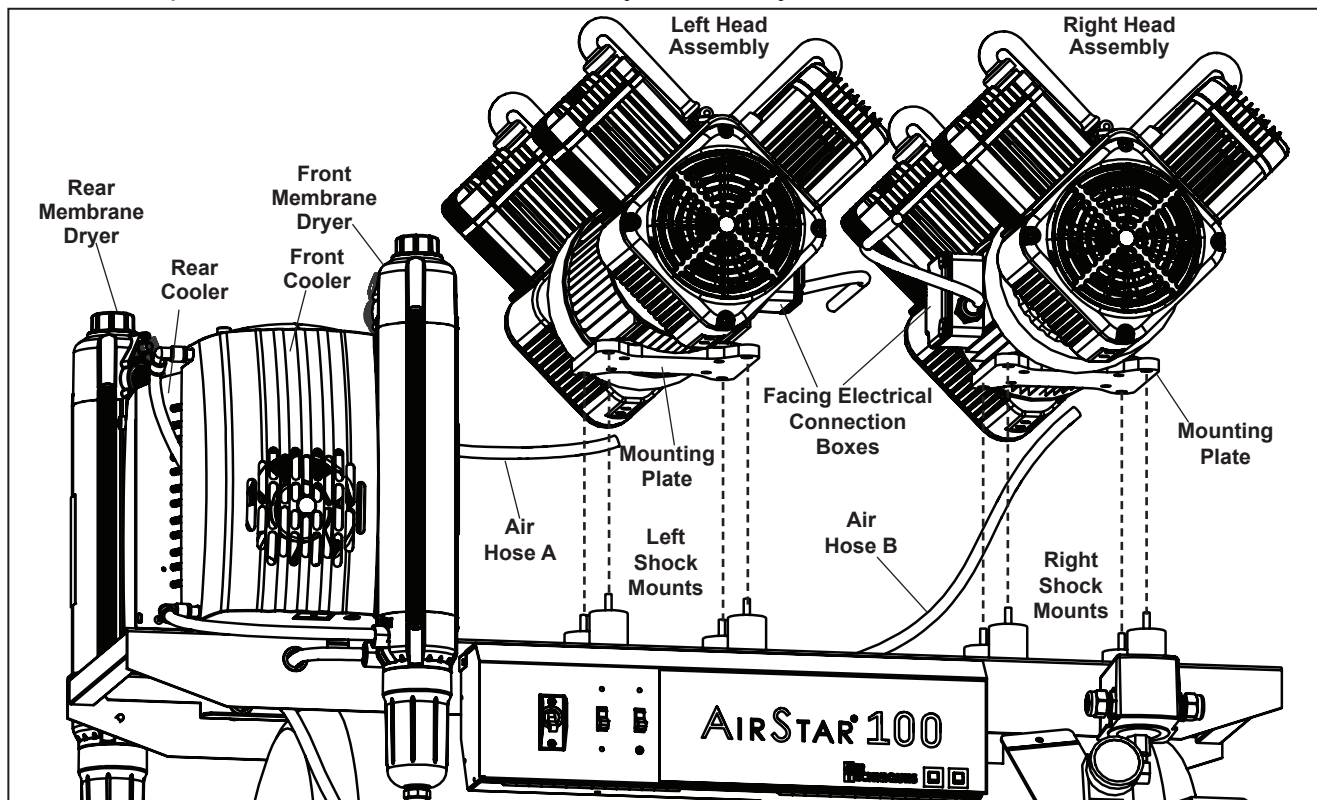

Figure 3. Left and Right Head Assembly Installation

INSTALLATION INFORMATION



Make sure all system power is removed prior to working with electrical circuits. Contacting high voltage can cause serious injury or even death.

- Install strain relief to the motor harness of the left and right head assemblies. Connect each harness as shown by Figure 4. Make sure to run each harness through their associated clips.
- Connect air hose A to left head assembly and air hose B to right head assembly.

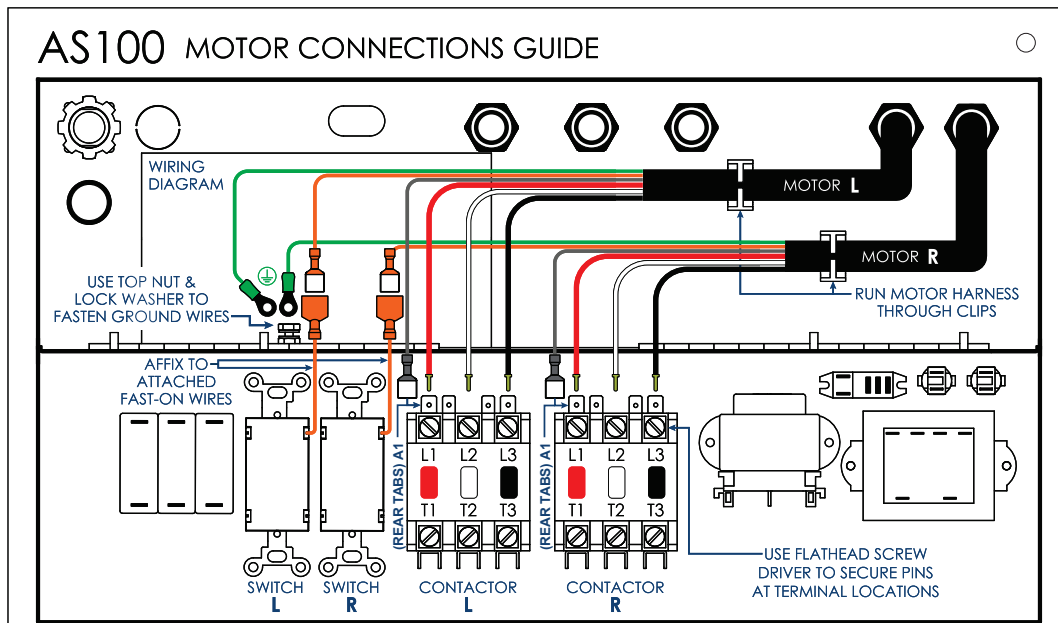
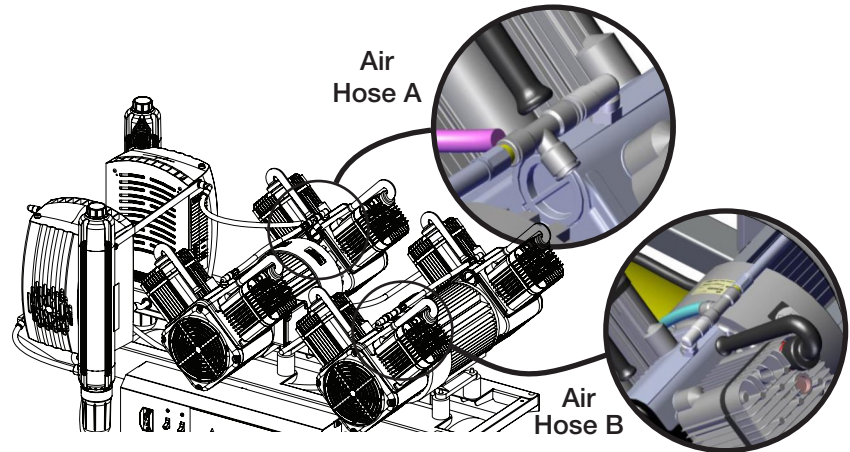

Motor Harness Connections

From Left Motor Harness	To Electrical Box	From Right Motor Harness	To Electrical Box
Green	Ground	Green	Ground
Orange	Switch L	Orange	Switch R
Gray	Contactor L - A1 Tab (under L1)	Gray	Contactor R - A1 Tab (under L1)
Red	Contactor L - L1 Box Lug (over A1)	Red	Contactor R - L1 Box Lug (over A1)
White	Contactor L - L2 Box Lug	White	Contactor R - L2 Box Lug
Black	Contactor L - L3 Box Lug	Black	Contactor R - L3 Box Lug

Figure 4. Left and Right Head Assembly Motor Connections

INSTALLATION INFORMATION

AIRSTARs are installed by authorized Air Techniques dealer technicians. Please review these installation guidelines to make sure that your **AIRSTAR** works to capacity for your office. (See Site Requirements, pages 8 & 9.)

- Your **AIRSTAR** should be installed in a well ventilated area, with at least 12 inch clearance on each side for service access and to prevent overheating during high demand periods. If other equipment is located in the vicinity, the ambient temperature of the area must not exceed 105°F.
- The installation site should be clean and dry to prevent the air intake filters from clogging. If there is a concern about the quality of air where the **AIRSTAR** is placed, we recommend an optional Remote Air Intake (See Optional Accessories, page 18) which allows the compressor to intake clean air from a remote location.
- Air distribution piping for all models should be 1/2", type "L" or type "K" copper.
- **PLUMBING CONNECTION:** The Tank Outlet Assembly (See Figure 1, View A), (the storage tank outlet for the dry air) is connected to the operatory air system via a 3/8" F.N.P.T. shut-off valve and 6 foot length of pressure hose (supplied).

Important: Each system should have a dedicated circuit panel.



Remove all power to the system prior to working with electrical circuits. Contacting high voltage can cause serious injury or even death.



All systems must be wired directly from an electrical box that complies with local electrical codes.

Note: If voltage is higher than 132V/242V, install a bucking transformer.

- **MINIMUM VOLTAGE:** The minimum voltage for an AS10 or AS21 is 108 Volts. The minimum voltage required for an AS12, AS22, AS30, AS40, AS50, AS70 or AS100 is 198 Volts. Install a boost transformer if the service is below these ratings.
- **WIRING REQUIREMENTS:** To help prevent fire, electric shock, injury, or death, the wiring and grounding must conform to the latest edition of the National Electrical Code, ANSI/NFPA 70 and all applicable local regulations. Please contact a qualified electrician to check your wiring and breakers/fuses to ensure that there is adequate electrical power to operate the **AIRSTAR**.
- **EQUIPMENT GROUNDING:** All **AIRSTARs** must be connected to a grounded metal, permanent wiring system, or an equipment grounding conductor must be run with the circuit conductors and connected to the equipment grounding lead in the **AIRSTAR's** flexible metal conduit power supply. Failure to do so can result in fire, electric shock, injury, or death. See Figure 2, Overall Site Requirements, page 9.
- **ELECTRICAL POWER CONNECTION:** AS10, AS12, AS21, AS22, AS30 and AS40 systems are supplied with a connected line cord. AS50, AS70 and AS100 systems are shipped with open electrical connections. Systems supplied with a line cord must be plugged into a hospital grade electrical outlet. See Figure 2 for receptacle requirements. Systems with open electrical connections are directly connected to the branch supply circuit as shown by Figure 3. See Site Electrical Requirements, page 9, for required branch circuit size for each system.

INSTALLATION INFORMATION

- 24VDC CONNECTIONS:** 24VDC connections are used when installing a 24VDC remote switch. Make the 24VDC connections shown by Figure 3 for the remote switch. When not using the remote switch, insulate the BRN wire and tie the ORG and YEL wires together.

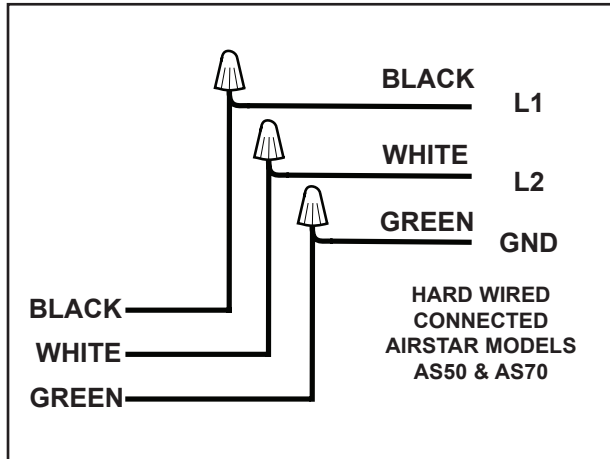

AS50 and AS70
Electrical Connections

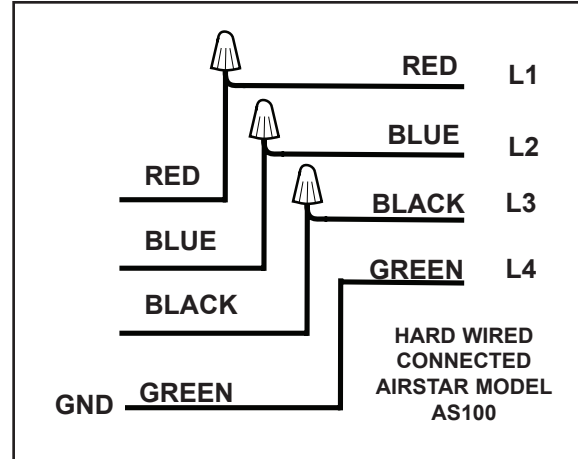

AS100
3-Phase Electrical Connections

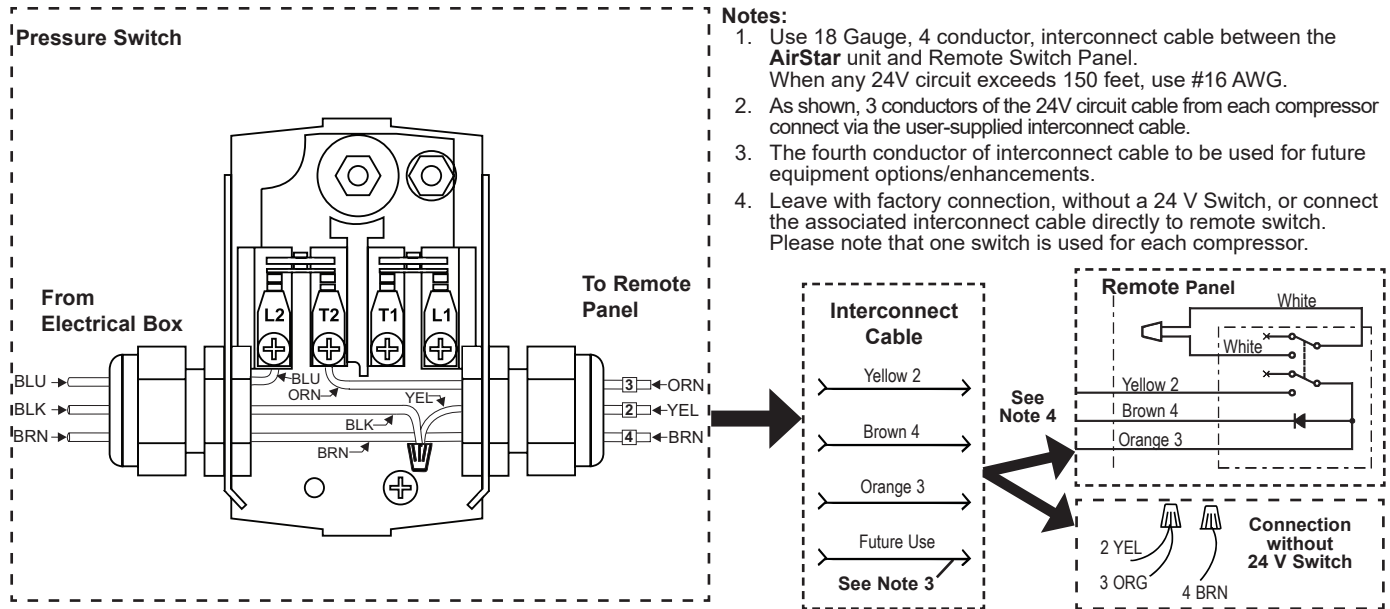

24VDC Connections

Notes:

- Use 18 Gauge, 4 conductor, interconnect cable between the **AirStar** unit and Remote Switch Panel. When any 24V circuit exceeds 150 feet, use #16 AWG.
- As shown, 3 conductors of the 24V circuit cable from each compressor connect via the user-supplied interconnect cable.
- The fourth conductor of interconnect cable to be used for future equipment options/enhancements.
- Leave with factory connection, without a 24 V Switch, or connect the associated interconnect cable directly to remote switch. Please note that one switch is used for each compressor.

Figure 5. Airstar Electrical Connections

INSTALLATION INFORMATION

POST INSTALLATION CHECK

Make Sure Everything Is Running Properly

After your **AIRSTAR** has been installed and before it is put into operation, be sure to follow the check-out procedure detailed below:

- Check that Intake Filter(s) are fully seated into the compressor head(s) and that the Tank Outlet Valve is closed.
- Turn on the electricity. Check the incoming line voltage. It should be at least 108 Volts for the AS10 and AS21; and 198 Volts for the AS12, AS22, AS30, AS40, AS50, AS70 and AS100. This voltage should remain at or above these levels while the **AIRSTAR** is running. If not, install the appropriate boost transformer and check that the correct main circuit breaker and wire size are being used.
- Check pump-up and recovery times as detailed below and compare to the times in the table.
 - Turn on the **AIRSTAR**'s power and determine the pump-up time from 0-115 PSI. See the table below.
 - Drain the storage tank to 80 PSI and determine the recovery time from 85 to 115 PSI. See the table below.

Model	Number of Motors/Heads	Pump-up Time 0-115 PSI Maximum	Recovery Time 85-115 PSI Maximum
AS10	1/1	2 minutes, 55 seconds	48 seconds
AS12	1/1	2 minutes, 55 seconds	48 seconds
AS21	1/2	3 minutes, 10 seconds	47 seconds
AS22	1/2	3 minutes, 10 seconds	47 seconds
AS30	2/2	3 minutes, 10 seconds	47 seconds
AS40	2/3	1 minute, 40 seconds	34 seconds
AS50	2/4	2 minutes, 50 seconds	42 seconds
AS70	3/6	2 minutes, 40 seconds	40 seconds
AS100	2/8	2 minutes, 15 seconds	30 seconds

If the recovery time differ as listed above, call authorized dealer for service.

TROUBLESHOOTING

Problem	Possible Cause	Possible Solutions
1. Motor does not start.	<ul style="list-style-type: none"> a. No electric power. b. Power not connected. c. Defective circuit breaker. 	<ul style="list-style-type: none"> a. Check circuit breaker at main power panel. b. Check 24 Volt remote connections. c. Circuit breaker needs to be replaced. Call your authorized Air Techniques dealer for service.
2. Motor tries to start, circuit breaker trips off. (* See bottom page 14)	<ul style="list-style-type: none"> a. Voltage too low.If each compressor head runs separately,but will not run together, the voltage is too low. b. Power supply cable too small. c. Loose electrical connection. 	<ul style="list-style-type: none"> a. AS10 and AS21 require a minimum of 108 Volts. AS12, AS22, AS30, AS50, AS70 and AS100 require a minimum of 198 Volts. If the voltage is below the required minimum, a boost transformer must be installed. Call your authorized dealer. b. See SITE REQUIREMENTS Table. c. Call your authorized dealer for service.
3. Unusual noise.	<ul style="list-style-type: none"> a. Intake filter(s) not seated correctly. b. Intake filter(s) clogged or dirty. c. Motor noise. d. Air leaks e. Check cooling fans 	<ul style="list-style-type: none"> a. Remove filter(s). Replace if clogged or dirty. When installing, make sure filter chamber is clean and rubber flange on top of filter is pushed all the way down into the metal cylinder b. Replace filter(s). (PN 89831) c. Call your authorized dealer for service. d. Call your authorized dealer for service. e. If fan is loose or broken, call your authorized dealer for service.
4 Compressor cycles but no pressure buildup to 115 psi.	<ul style="list-style-type: none"> a. Motor noise. b. Leak in compressor. c. Pressure switch needs to be adjusted. 	<ul style="list-style-type: none"> a. Replace filter(s). (PN 89831) b. Close the storage tank outlet valve. Check all fittings for leaks. If a leak is found, call your authorized dealer for service. c. Disconnect the main power supply. Drain the storage tank slowly until a “click” is heard. Storage tank pressure should read 85 PSI on the pressure gauge. Close the tank outlet valve, turn on the power switch and verify the pump-up time for your model AirStar. Call your authorized dealer if the pump-uptime is incorrect. (See Post Installation Check for pump-up times.)

TROUBLESHOOTING

Problem	Possible Cause	Possible Solutions
5. Compressor cycles even when there is no air demand from the operatory.	<p>a. Leak in the compressor.</p> <p>b. Leak in the office air system.</p>	<p>a. Disconnect the main power supply. Drain the storage tank slowly until a “click” is heard. Storage tank pressure should read 85 PSI on the pressure gauge. Close the tank outlet valve, turn on the power switch and verify the pump-up time for your model AirStar. Call your authorized Air Techniques dealer if the pump-up time is incorrect. (See Post Installation Check for pump-up times.)</p> <p>b. Look at the moisture monitor (see KEY PARTS to locate). If it is blue, perform the following:</p> <ol style="list-style-type: none"> 1. With the AirStar's power switch ON, drain the storage tank to 85 PSI to start the compression cycle. 2. When the cycle shuts off at 115 PSI, close the storage tank outlet valve. 3. Wait 5 minutes and open the storage tank outlet valve. 4. If the pressure drops, the air leak is in the office air system or delivery units and not in the AirStar. Call your dealer or plumber for service. <p>If it is pink, see #6 below</p>
6. Moisture monitor is not blue (pink or white).	<p>a. Leak in the office air system.</p> <p>b. Compressor keeps cycling.</p>	<p>a. If the moisture monitor is pink, there is too much moisture in the system. Call your authorized Air Techniques dealer for service.</p> <p>b. Check the SIZING GUIDE. There may be excessive air demands placed on the AirStar. A larger capacity model may be required.</p>

*DIAGNOSTIC PROCEDURE FOR DEFECTIVE COMPRESSOR HEAD(S)

1. Put power switches in the OFF position.
2. Reset the circuit breaker if it was previously tripped.
3. Test heads by turning ONE on at a time. If the motor fails to start, or the circuit breaker trips, the problem may be in that compressor head. Leave the power switch for the effective head in the OFF position. Call your Authorized Air Techniques dealer for service.

NOTE: One head may be run TEMPORARILY while waiting for service.

4. If all heads run independently, but will not run together, check the line voltage. If the voltage is within the min./max. voltage required in PRODUCT SPECIFICATIONS, call your Authorized Air Techniques dealer for service.

Like all precision products, your **AIRSTAR** requires a certain amount of care on a regularly scheduled basis. A well-organized maintenance program aids dependable equipment operation and reduces problems to a minimum. Routine checks help to detect general overall wear, and replacement of parts can often be made before a problem occurs.

Understanding this, we have established minimum maintenance requirements listed below that include routine inspections and the replacement of filters using preventive maintenance kits available for the specific **AIRSTAR** model. Adherence to this recommended maintenance schedule will ensure that the equipment will continue performing at its best with uninterrupted service.

■ Routine Inspection - Monthly

Clean exterior surfaces.

Check for abnormal noises and air leaks.

Make sure that no flammable, corrosive, or combustible materials are stored in the equipment room (especially in the area around the equipment).

Check operational range of pressure switch is between 85-115 psi.

Inspect the Moisture Monitor (Figure 4) for a color change:

Blue indicates that the air in the storage tank is dry.

Pink indicates a high level of humidity is in the storage tank. See TROUBLESHOOTING page 14 to correct this situation.

Note: To comply with NFPA 99C, a 5-micron Filter is installed on the output of all **AIRSTAR** models.

■ Routine Inspection - Yearly

Refer to Figure 4 and check the Service Indicator on the 5-micron Outlet Filter.

Red indicates that the filter must be replaced P/N 87168.

Green indicates No service is required.

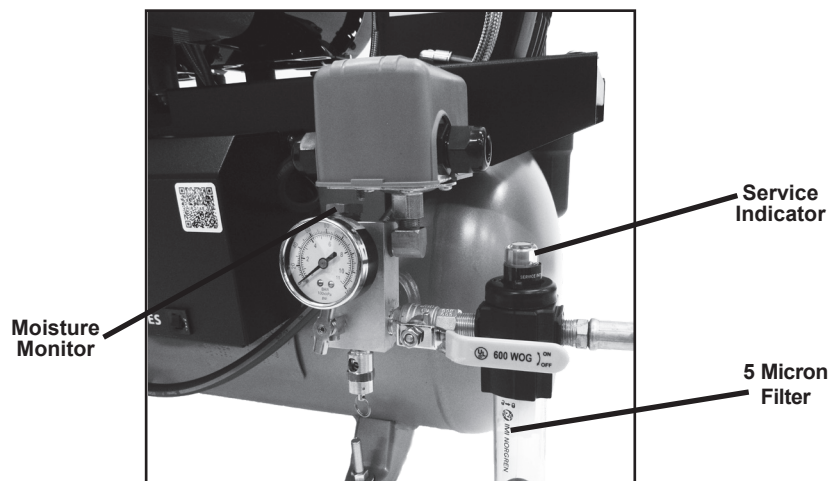

Figure 6.
Moisture Monitor and 5-Micron Filter Location

MAINTENANCE

Important: In dusty environments, the Intake Filter, PN 89938, may need to be changed more often than once a year.

Always dispose of the removed filter in accordance with local codes.

■ Filter Replacement - Yearly

Refer to Figure 5 for the location of filters to be replaced using the preventive maintenance kit for the specific **AIRSTAR** mode listed below. Replace the filters and associated O-rings in accordance with the instructions provided with the kit.

Preventive Maintenance Kits Supplied Components

AirStar Model		AS10 & AS12	AS21, AS22 & AS30	AS40	AS50	AS70	AS100
Kit Part No		87351	87352	87355	87353	87354	87356
Component	Part No.	Qty	Qty	Qty	Qty	Qty	Qty
Compressor Air Intake Filter	89938R	1	2	3	4	6	8
Top Membrane Filter	87366	1	1	1	1	2	2
Bottom Membrane Filter & Bowl	86787	1	1	1	1	2	2
Top Cover O-ring	87368	1	1	1	1	2	2
Filter Bowl O-ring	85529	1	1	1	1	2	2

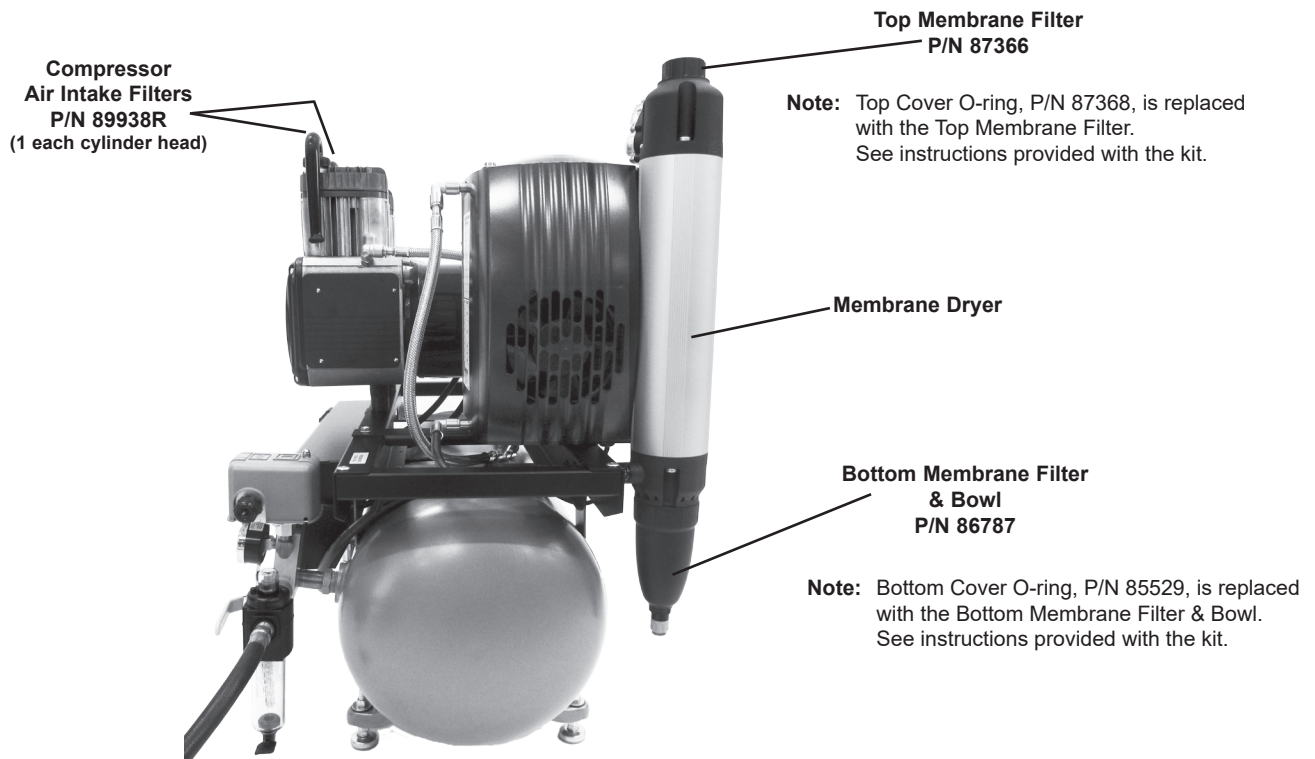
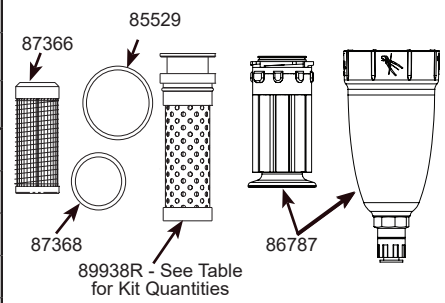

Figure 7.
AirStar Filter Location

SERVICE TIMER

Alerts User to Perform Scheduled Maintenance

The Service Timer is designed to track, in hours, the operating time of the **AIRSTAR** motors and alerts the user when regularly scheduled preventive maintenance is due. (See View A.)

The typical interval between servicing is 1,000 hours of operation. The tracking is done by setting the timer to 1,000 hours at the start of each new service period and having the timer count down only during operation when the motors are working. When the Service Timer reaches 100 hours or less, a **SVC DUE** message appears (See View B.) once every minute to indicate it will soon be time to perform preventive maintenance.

When the service timer has counted down 1,000 hours, a **SVC NOW** message flashes to indicate it is time to do preventive maintenance on your **AIRSTAR**. (See View C.) The Timer Display alternates between the service due and time remaining screens.

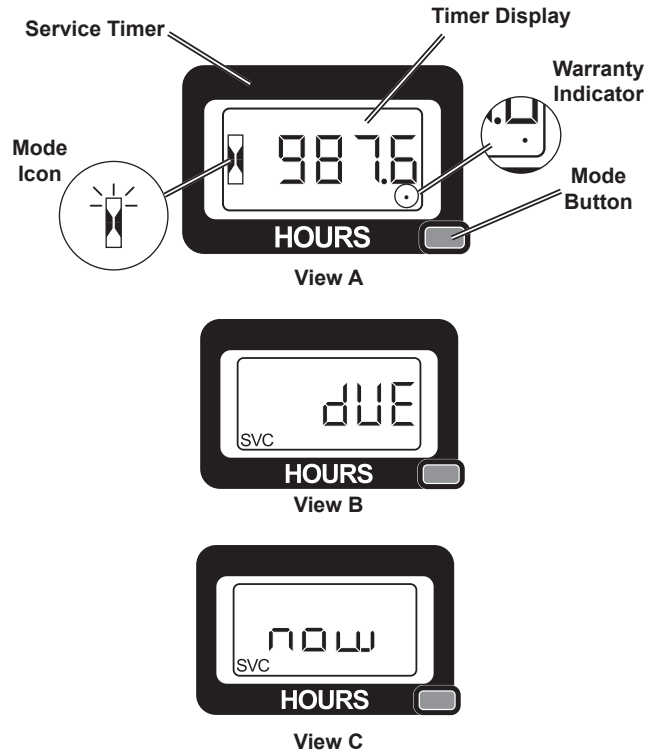

Figure 8. Service Timer

The Service Timer feature is included to help the user adhere to the recommended maintenance schedule provided in this manual. Timely performance of this maintenance ensures that your **AIRSTAR** will provide uninterrupted service and continue to perform at its best. The only user action necessary is as follows.

1. Perform the preventive maintenance when alerted.
2. Reset the Service Timer for the next service interval.

Refer to the table below summarizing the Service Timer functions as necessary.

Timer Display: When set in the Hour Meter Mode, shows the total number of operating hours the unit has run. (See View A.)

Displays service alerts in SVC DUE Mode when timer reaches the 100 and 1000 hour default intervals. (See Views B and C.)

NOTE: The Mode Icon blinks when Mode Button is pressed. 

Mode Button: Allows selection between the Hour Meter Mode and the SVC DUE Mode.

1. When in SVC DUE Mode, press the Mode Button once to return to the Hour Meter Mode.
2. Resets service timer when held down for 6 seconds.

NOTE: The dot indicator appears only after the first 2 hours of running time. (See View A.)

Warranty (dot) Indicator: The Warranty Indicator is the dot in the lower right hand corner that tracks the warranty period. When blinking, the until is still within the 5,000 hours warranty period. The 5,000 hours warranty period has elapsed if the dot is solid (stops blinking).

REPLACEMENT PARTS

Description	Part No.
5 Micron Replacement Filter	87168

Preventive Maintenance Kits

AirStar Model	Kit Part No.
AS10 & AS12	87351
AS21 AS22 AS30	87352
AS40	87355
AS50	87353
AS70	87354
AS100	87356

OPTIONAL ACCESSORIES

Description	Model	Part Number	
REMOTE AIR INTAKE KIT	AirStar 10 & 12	85491	
	AirStar 21, 22, 30	85492	
	AirStar 40	87361	
	AirStar 50	85493	
	AirStar 70	85494	
	AirStar 100	85511	
REMOTE CONTROL PANEL w/24 V switches	For all AirStars	1-Switch Plate Kit	53111
		2-Switch Plate Kit	53251
		3-Switch Plate Kit	53250
		4-Switch Plate Kit	53133
		SOUND COVER	AirStar 10
AirStar 12	85180		
AirStar 21	85962-1M		
AirStar 22	85962-2M		
AirStar 30	85963M		
AirStar 40	87440M		
AirStar 50	89523M		
AirStar 70	89574M		

PRODUCT SPECIFICATIONS

AirStar Model		AS10	AS12	AS21	AS22	AS30	AS40	AS50	AS70	AS100
Requirement										
Phase Φ		1	1	1	1	1	1	1	1	3
Horsepower		0.75	0.75	1.5	1.5	1.5	2.25	3.0	4.5	4.8
Kilowatts		0.56	0.56	1.1	1.1	1.1	1.68	2.2	3.4	3.6
Voltage Rating		120	220	120	220	220	220	220	220	220
Frequency (Hz)		60	60	60	60	60	60	60	60	60
Maximum Number of Simultaneous Air Users		2	2	3	3	4	5	7	10	14
CFM (Cubic Ft./Min) @ 80 psi		2.5	2.5	5.0	5.0	5.0	7.5	10.0	15.0	20.0
Pump-up Time 0-115 PSI		2 min, 55 secs	2 min, 55 secs	3 min, 10 secs	3 min, 10 secs	3 min, 10 secs	1 min, 40 secs	2 min, 50 secs	2 min, 40 secs	2 min, 30 secs
Recovery Time 85-115 PSI (seconds)		48	48	47	47	47	34	42	40	30
Tank Size (cu. ft.) (US Gal.)		0.8 6	0.8 6	1.6 12	1.6 12	1.6 12	1.6 12	2.7 20	4.0 30	4.0 30
Shipping Weight (Approximate lbs)		170 215	170 215	200 240	200 240	240 285	255 300	290 335	430 N/A	450 N/A
Dimensions (inches)	H	28.50	28.50	30.50	30.50	30.50	30.50	33.50	35.00	34.50
	W	25.00	25.00	29.00	29.00	29.00	32.50	35.50	47.75	46.00
	D	19.75	19.75	20.00	20.00	20.00	20.00	20.50	21.75	24.50
With Sound Cover	H	30.00	30.00	32.00	32.00	32.00	32.25	33.50	36.00	N/A
	W	25.00	25.00	31.00	31.00	31.00	33.25	36.50	51.00	N/A
	D	22.50	22.50	22.25	22.25	22.25	22.50	22.75	29.50	N/A

WARRANTY

Each **AIRSTAR** is warranted to be free from defects in material and workmanship from the date of installation for a period as follows:

- Full System Warranty: 2 years (24 months) or 2,000 hours.
- Specific Component Warranty: 5 years (60 months) or 5,000 hours Whichever comes first on all motors, heads, PCBs and membrane dryers.*

**For eligibility customer must provide confirmation in the form of a dealer invoice to the dentist that preventative maintenance kit or coalescent filter was installed on the unit within two thousand (2,000) hours or latest after twenty four (24) months of failure (whichever comes first). (PINs 87351 -87355 & 87367).*

All part and component returns and replacement equipment require a Return Materials Authorization (RMA). Returns must be received within three months of the RMA issue date and in appropriate packaging to prevent shipping damage. In case of advanced replacement, products shall be returned in the original packaging. Items returned without an RMA, or included with other products for which an RMA has been issued, will be returned to the customer at the discretion of Air Techniques, Inc.; the return shipping is the customer's responsibility.

Any item returned under warranty, will be repaired or replaced at our option at no charge provided that our inspection confirms it to be defective. Air Techniques, Inc. is not liable for indirect or consequential damages or loss of any nature in connection with this equipment. Dealer labor, shipping and handling charges are not covered by this warranty.

Warranty credit will not be applied to product returns that exhibit damage due to shipping, misuse, careless handling, and improper installation by dealers, or repairs by unauthorized personnel. Credit, or partial credit, will not be issued until products/parts have been received and assessed. If, after the evaluation it is determined that there is no-fault found and the unit is working properly, a credit will not be issued. Warranty is void if product is installed incorrectly or installed or serviced by anyone other than an authorized Air Techniques' dealer or service personnel.

This warranty is in lieu of all other warranties expressed or implied. No representative or person is authorized to assume for us any liability in connection with the sale of our equipment.

ON-LINE WARRANTY REGISTRATION

Quickly and easily register your new **AIRSTAR** on-line. Just have your product model and serial numbers available. Then go to the Air Techniques web site, www.airtechniques.com/dental, click the **warranty registration** link and complete the registration form. This on-line registration ensures a record for the warranty period and helps us keep you informed of product updates and other valuable information.

For over 50 years, Air Techniques has been a leading innovator and manufacturer of dental products. Our priority is ensuring complete satisfaction by manufacturing reliable products and providing excellent customer and technical support. Whether the need is digital imaging, utility room equipment or merchandise, Air Techniques can provide the solution via our network of authorized professional dealers. Proudly designed, tested and manufactured in the U.S., our products are helping dental professionals take their practices to the next level.

Air Techniques' family of quality products for the dental professional include:

- Digital Imaging**
 - Digital Radiography
 - Intraoral Camera
 - Caries Detection Aid
 - Intraoral X-ray
 - Panoramic X-ray
 - Film Processors

- Utility Room**
 - Dry Vacuums
 - Wet Vacuums
 - Air Compressors
 - Amalgam Separator
 - Utility Accessories
 - Utility Packages

- Merchandise**
 - Surface Disinfectant
 - Enzymatic Cleaner
 - Hand Sanitizer and Lotion
 - Waterline Cleaner
 - Evacuation System Cleaner
 - Imaging Accessories
 - Chemistry
 - Processor Accessories

Corporate Headquarters

1295 Walt Whitman Road | Melville, New York 11747- 3062
Phone: 800-247-8324 | Fax: 888-247-8481

www.airtechniques.com



AirStar is a registered trademark of Air Techniques, Inc.
© Copyright 2009 • P/N 87109, Rev. T • February 2018