

## Instructions for Use

# A-dec 500 Delivery Systems

Models 532, 533, and 542

## Copyright

© 2016 A-dec Inc. All rights reserved.

A-dec Inc. makes no warranty of any kind with regard to this material, including, but not limited to, the implied warranties of merchantability and fitness for a particular purpose. A-dec Inc. shall not be held liable for any errors contained herein or any consequential or other damages concerning the furnishing, performance or use of this material. The information in this document is subject to change without notice. If you find any problems in the documentation, please report them to us in writing. A-dec Inc. does not warrant that this document is error-free.

No part of this document may be copied, reproduced, altered, or transmitted in any form or by any means, electronic or mechanical, including photocopying, recording, or by any information storage and retrieval system, without prior written permission from A-dec Inc.

## Trademarks and Additional Intellectual Property Rights

A-dec, the A-dec logo, A-dec 300, Cascade, Cascade Master Series, Century Plus, Continental, Decade, ICX, ICV, Performer, Preference, Preference Collection, Preference ICC, and Radius are trademarks of A-dec Inc. and are registered in the United States and other countries. A-dec 500, A-dec 400, A-dec 200, A-dec Inspire, Preference Slimline, and reliablecreativesolutions are also trademarks of A-dec Inc. None of the trademarks or trade names in this document may be reproduced, copied, or manipulated in any manner without the express, written approval of the trademark owner.

Certain touchpad symbols are proprietary to A-dec Inc. Any use of these symbols, in whole or in part, without the express written consent of A-dec Inc., is strictly prohibited.

## Regulatory Information

Regulatory information mandated by agency requirements is provided in the *Regulatory Information, Specifications, and Warranty* document (p/n 86.0221.00), which is available in the Document Library at [www.a-dec.com](http://www.a-dec.com).

## Product Service

Product service is available through your local authorized A-dec dealer. For service information, or to locate an authorized dealer, contact A-dec at 1.800.547.1883 in the USA and Canada or 1.503.538.7478 worldwide, or visit [www.a-dec.com](http://www.a-dec.com).

## Product Models and Versions Covered in This Document

Model	Versions	Description
532	A	Delivery System
533	A	Delivery System
542	A	Delivery System

# Content Map

Touchpad .....6



Master Toggle .....2

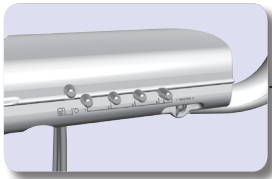

Handpiece Flush .....27

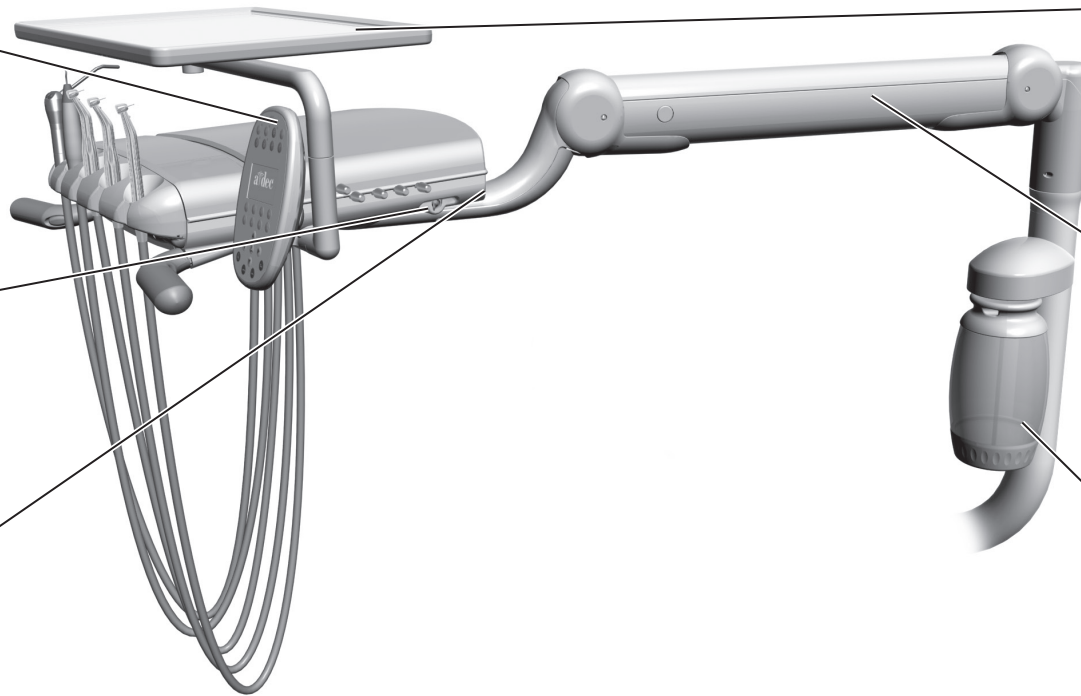
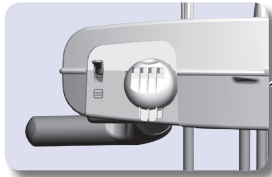

Tray Holder .....21



Flexarm ..... 5, 22, 24

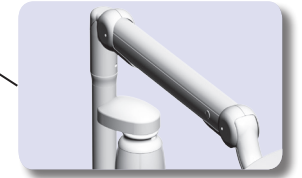

Water Bottle ..... 26

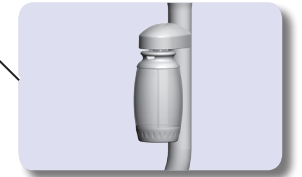

Operate / Adjust .....	2
Clean / Maintain.....	26
Specifications and Warranty.....	31

# Operate / Adjust

## Power On/Off

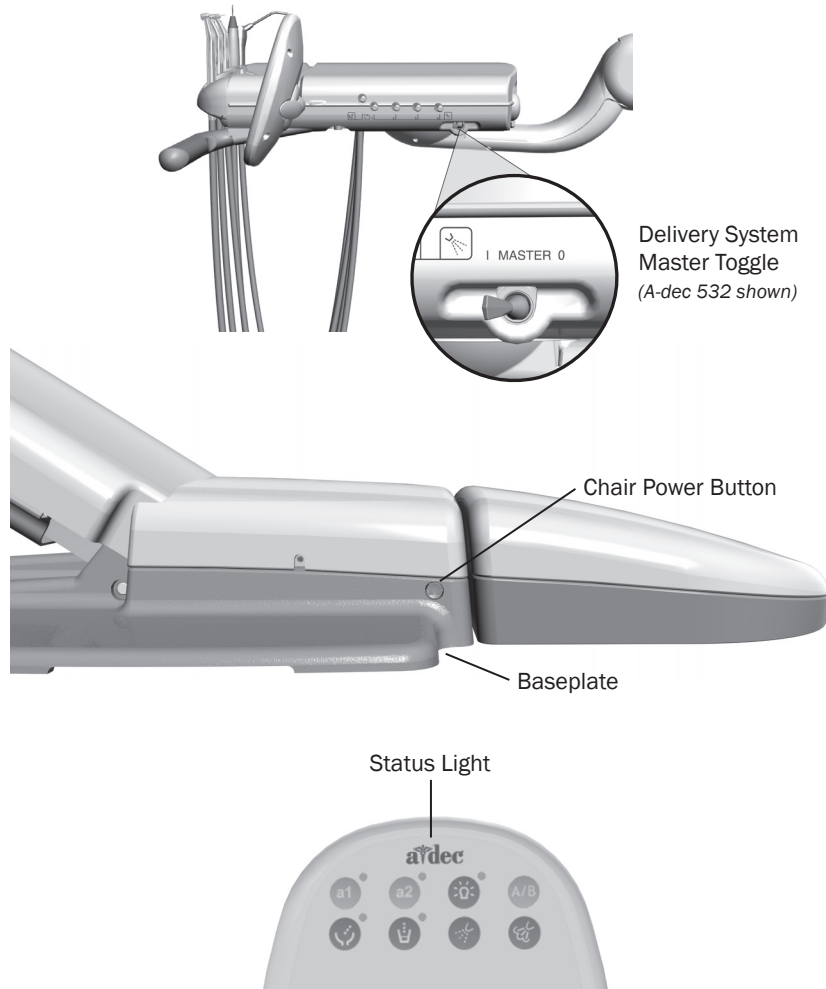

**NOTE** A-dec recommends that you perform a shock treatment on the dental unit waterlines before you use the system for the first time. For more information, see “Waterline Maintenance” on page 26.

### Master Toggle

Use the master toggle to turn on the power, water, and air. The master toggle is normally located on the delivery system, but may instead be located on the cuspidor, support center, or remote floor box, depending on your configuration.

If there is no power to the system, verify that the chair power button is pushed in. The chair power must be on in order for the master toggle to control system power.

### When to Turn Off the Power

To save energy, turn off the power at the end of the work day and during longer periods of non-use.

### Touchpads and the Status Light

The A-dec logo on the touchpad illuminates when the system is on and ready for use. If the status light blinks, it may indicate that a safety feature has interrupted chair motion. See “Chair Safety Features” on page 3 for more information.

For complete details on touchpad functionality, please see “Touchpad Controls” on page 6.

## Chair Safety Features

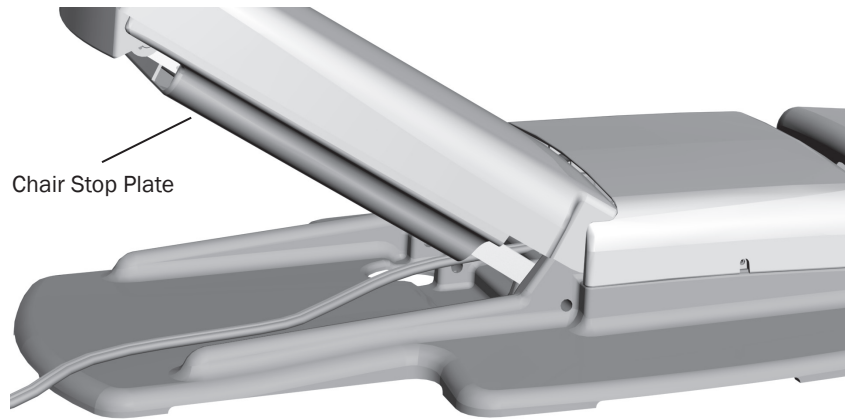

A-dec dental chairs and systems include several features designed to improve safety. Activated stop switches may halt the chair or prevent it from moving. To help ensure uninterrupted chair motion:

- remove any potential obstructions under the chair and attached modules
- avoid pressing the foot control disc or lever
- keep handpieces properly seated in their holders

### If the Chair Stops Unexpectedly

Check the actions listed above to correct the condition. If the downward movement of the chair stopped because of an obstruction, use the touchpad or footswitch to raise the chair and remove the obstruction.

## Autoclavable Syringe

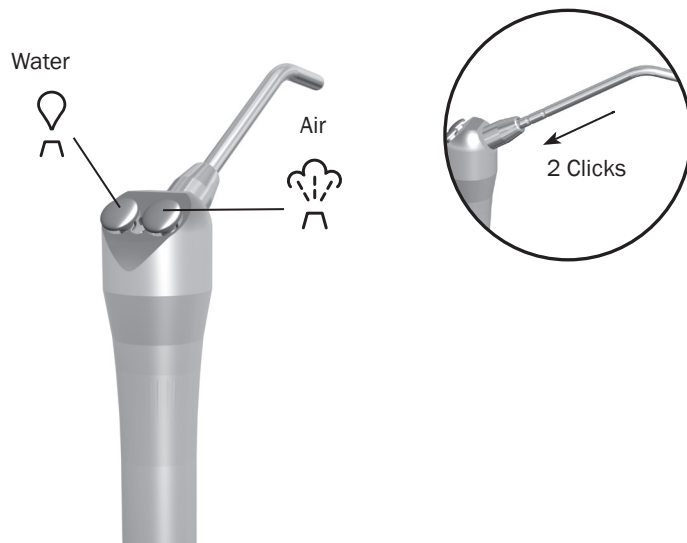

To install the A-dec syringe tip, push the tip in until you feel two clicks. Press both buttons simultaneously for the air/water spray.



**IMPORTANT** For detailed instructions on syringe usage, flow adjustment, and maintenance, see the *A-dec Syringes Instructions for Use* (p/n 85.0680.00).

## Handpiece Activation and Operation

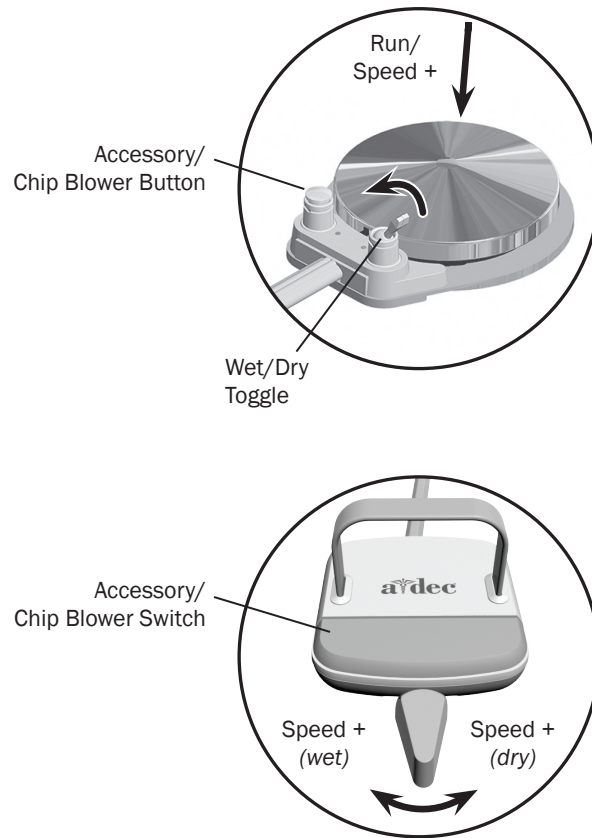

**NOTE** The lever foot control function can be reversed by a technician (change left direction to dry, right direction to wet). For more details, contact your authorized A-dec dealer.

To activate a handpiece, lift it from the holder or pull the whip forward. Use the foot control to perform the desired handpiece operation.



**NOTE** The disc foot control has additional functionality when used with a deluxe touchpad or an intraoral camera. The wet/dry toggle operates as a three-way switch with the air and water coolant buttons on the touchpad.

Control	Operation	Procedure
<b>Disc Foot Control</b>	Run a handpiece.	Press on the disc. Push down to increase speed.
	Run a handpiece with or without water coolant.	Use the water coolant button on the deluxe touchpad to turn the coolant on or off, or move the wet/dry toggle toward the blue dot for wet operation or away from the blue dot for dry operation. Then press on the disc.
	Run the optional accessory or chip blower.	Press the accessory/chip blower button.*
<b>Lever Foot Control</b>	Operate the intraoral camera.	Press on the disc to capture an image.*
	Run a handpiece with water coolant.	Move the lever to the left. Move farther to increase speed.
	Run a handpiece without water coolant.	Move the lever to the right. Move farther to increase speed.
	Run the optional accessory or chip blower.	Press the accessory/chip blower switch.*
	Operate the intraoral camera.	Move the lever to the left or right to capture an image.*

\* Contact your authorized A-dec dealer for questions about the operation or configuration of your integrated A-dec accessories.

## Control Head Positioning



### Flexarm Brake

The integrated brake maintains the vertical position of the control head (with up to 8 lb [3.6 kg] of additional weight). The brake does not restrict side-to-side movement.

To adjust the control head height:

1. Press and hold the button to disengage the brake while you position the control head.
2. Release the button to engage the brake.



## Touchpad Controls



The A-dec touchpad and footswitch control chair movement in the same way. See your dental chair Instructions for Use for detailed information about your footswitch controls.

### Basic Touchpad Functions

Your A-dec 500 system may include a standard or deluxe touchpad. The standard touchpad operates the chair, cuspidor, and dental light functions. The deluxe touchpad adds functions for electric motors and other integrated clinical devices. Both touchpads provide manual and programmable controls.



Standard Touchpad



Deluxe Touchpad



## Touchpad Controls *(continued)*

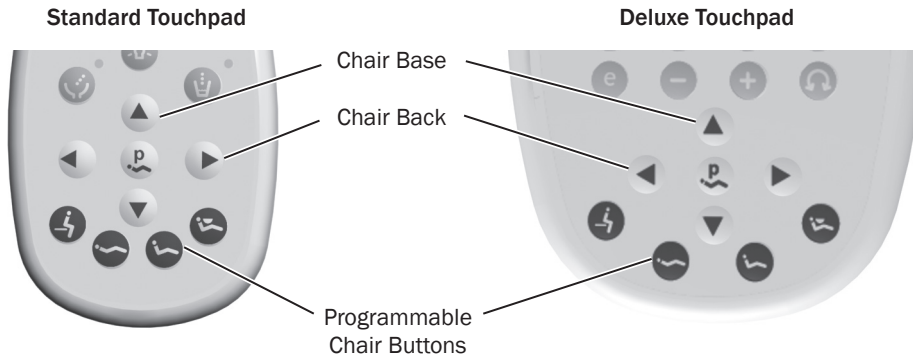

## Manual Chair Controls

Press and hold an arrow button until the chair is in the desired position. The horizontal arrows raise and lower the chair back. The vertical arrows raise and lower the chair base.

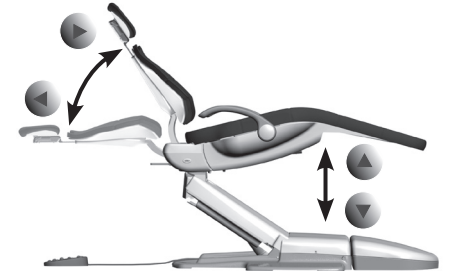

## Programmable Chair Controls

Press and release a programmable button to move the chair to a preset position. These buttons are programmed at the factory as follows:

Icon	Position	Factory Setting
	Entry/Exit	Positions the chair for patient entry/exit.
	Treatment 1	Positions the chair base and back down.
	Treatment 2	Positions the chair base down and back partially up.
	X-ray/Rinse	Moves the chair to either x-ray or rinse position. Press again to move the chair to the previous position.



**WARNING** Ensure that the patient is positioned safely before using the manual or programmable chair controls. Never leave the patient unattended while the chair is in motion. Always take extra care with small children and patients with limited mobility.

To stop the chair at any point during programmed movement, push any chair positioning button on the footswitch or touchpad.

*Note: Touchpad symbols are proprietary to A-dec Inc.*

## Touchpad Controls *(continued)*

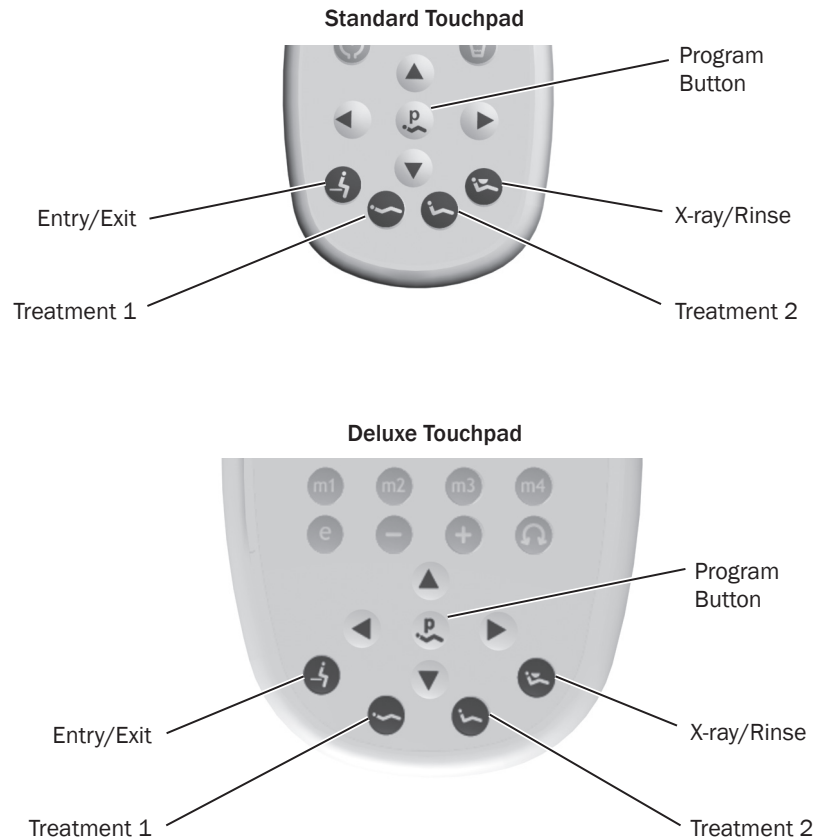

### Reprogram Entry/Exit, Treatment 1 and 2 Buttons

To change the factory preset chair positions assigned to the entry/exit and treatment buttons (🚼, 🦯, 🦯):

1. Use the manual controls to position the chair as desired.
2. Press and release 🦯. One beep indicates that the programming mode is on.
3. Within five seconds, press the chair position button you wish to reprogram (for example, press 🚼). Three beeps confirm that the new setting is programmed into memory.

### Reprogram X-Ray/Rinse Button

The x-ray/rinse button (🦯) is preset to move the chair and patient into an upright position for x-rays or cuspidor access. A second press of 🦯 returns the chair to the previous position.

You can reprogram 🦯 to function in a similar way to the other programmable chair preset buttons. To change its function:

1. Press and hold 🦯 and 🦯 at the same time for three seconds.
  - One beep indicates 🦯 is set as another programmable chair preset button.
  - Three beeps confirm that 🦯 is configured as the x-ray/rinse factory preset (which toggles between the x-ray/rinse and the previous chair position).
2. If you reprogram 🦯 as another programmable button and want to assign a different chair position, follow the steps outlined in "Reprogram Entry/Exit, Treatment 1 and 2 Buttons" above.

## Touchpad Controls *(continued)*

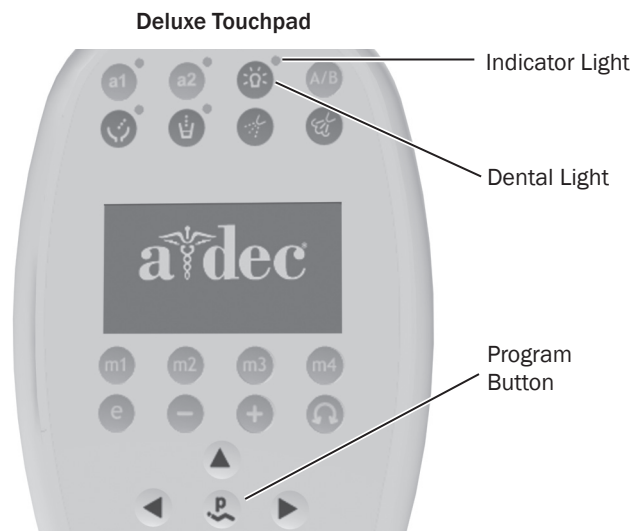
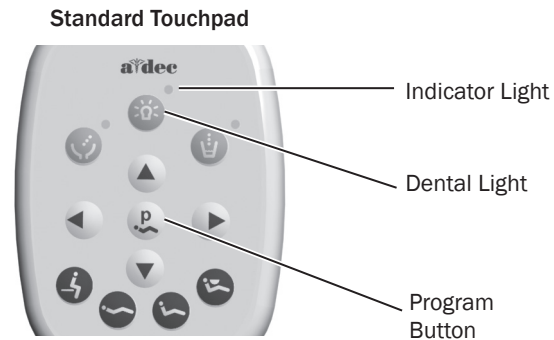

### Dental Light

You can turn the dental light on or off from either the touchpad or the dental light. The dental light button on the touchpad allows you to change intensity settings.

**Halogen Dental Light:** Press to toggle between high and composite or medium and composite. When the dental light is in composite mode, the indicator light blinks.

**LED Dental Light:** Press to choose the desired intensity mode. When the light is in cure-safe mode, the indicator light blinks.

To turn off the dental light, press and hold for three seconds.

### Dental Light Auto On/Off Feature

The auto on/off feature turns the A-dec light on once the chair reaches a preset treatment position.

When you press or , the dental light turns off and the chair moves to that preset position.

To disable the auto on/off feature, press and hold the program button and at the same time for three seconds until you hear one beep.

To enable the auto on/off feature, press and hold and at the same time for three seconds until you hear three beeps.

For more information about dental light functions, see your dental light Instructions for Use.

## Touchpad Controls *(continued)*

Standard Touchpad







Deluxe Touchpad



## Cuspidor Functions

Use the buttons under the cupfill spout or on the touchpad to control the bowl rinse and cupfill functions. The buttons support both programmed and manual operation.

Button	Description and Factory Presets
Cuspidor	<b>Bowl Rinse Operation:</b>
	<ul style="list-style-type: none"> <li>Press and release the bowl rinse button for a timed operation. The factory preset is a 30 second rinse.</li> </ul>
Touchpad	
	<ul style="list-style-type: none"> <li>Press and release the bowl rinse button twice in less than two seconds to activate the continuous operation mode. Press and release the button again to end the continuous mode.</li> <li>Press and hold the bowl rinse button for manual operation.</li> </ul>
Cuspidor	<b>Cupfill Operation:</b>
	<ul style="list-style-type: none"> <li>Press and release the cupfill button for a timed operation. The factory preset is a 2.5 second fill.</li> </ul>
Touchpad	
	<ul style="list-style-type: none"> <li>Press and hold the cupfill button for manual operation.</li> </ul>

## Customize Bowl Rinse or Cupfill Timing

To reprogram the timed bowl rinse or cupfill functions:

1. Press  on the touchpad, or press and hold the cupfill and bowl rinse buttons under the cupfill spout. Release the button(s) when you hear one beep.
2. Within five seconds, press and hold the cupfill or bowl rinse button for the desired time.
3. Release the button. Three beeps confirm that the program has changed.



**NOTE** If your system includes an A-dec relay module, refer to “Auxiliary Control Buttons” on page 17 for information.

## Touchpad Controls *(continued)*

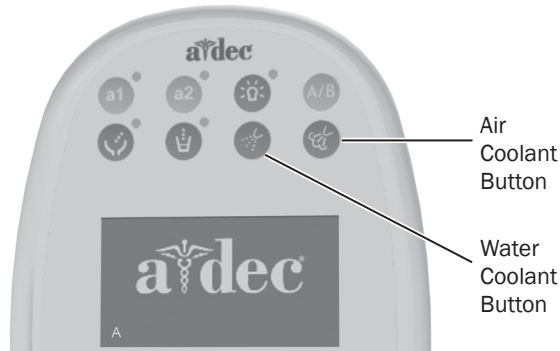

### Air and Water Coolant Buttons

On deluxe touchpads, the air coolant button (☀️) and the water coolant button (💧) turn on and off the flow of air coolant and water coolant to the handpiece.



**NOTE** When a lever foot control is installed, the air and water coolant buttons do not function.

### Euro Mode

This mode enables air and water coolant to be turned on or off simultaneously. When this mode is enabled, pressing either the air coolant button or the water coolant button will turn both the air and the water coolant on or off.

To enable Euro mode:

1. Press and hold the program button (🔧) and the air (☀️) or water coolant button (💧). Three beeps confirm the setting.

To disable Euro mode:

1. Press and hold the program button (🔧) and the air (☀️) or water coolant button (💧). One beep sounds.

### A/B Button

Deluxe touchpads include an A/B (A/B) button that offers you two sets of programmable settings. The currently active set is indicated by the A or B in the lower left corner of the touchpad display.

## Electric Handpiece Settings *(deluxe touchpad only)*

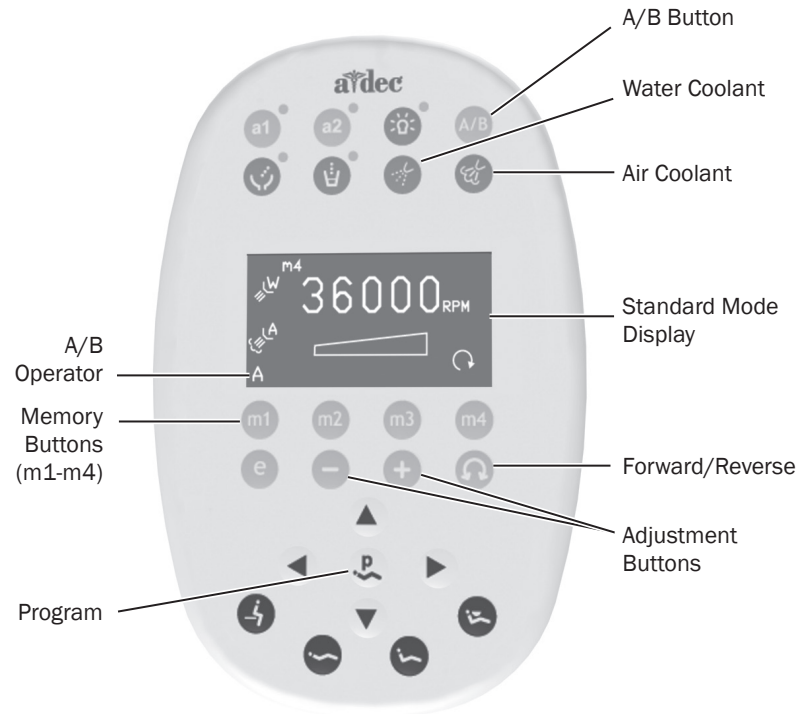

### Standard Mode

To activate the electric motor, lift the handpiece from the holder. The touchpad screen displays the previous settings used for that handpiece position. Standard mode provides four factory preset speeds for electric motors:

Memory Setting	Factory Preset Speed	Air Coolant	Water Coolant
m1	2,000 rpm	On	On
m2	10,000 rpm	On	On
m3	20,000 rpm	On	On
m4	36,000 rpm	On	On

You can reprogram these memory settings with your own specific preset speeds. With the A/B button, you can program two settings for each memory button, for a total of eight customized settings per handpiece. The endodontics mode offers an additional eight memory settings.

**NOTE** If two operators use the delivery system, be sure to select the correct operator set (A or B) before changing any memory settings. The currently active set is indicated by the A or B in the lower-left corner of the touchpad display.

To program the handpiece setting:

1. Press **+** or **-** until the rpm setting you want is displayed on the touchpad screen.
2. If desired, press or to change water and air coolant settings.
3. Press to save the settings to memory. One beep sounds.
4. Press m1, m2, m3, or m4 to choose the desired memory setting. Three beeps confirm the setting.

**NOTE** When a lever foot control is installed, the air and water coolant buttons do not function.

## Electric Handpiece Settings *(deluxe touchpad only)*

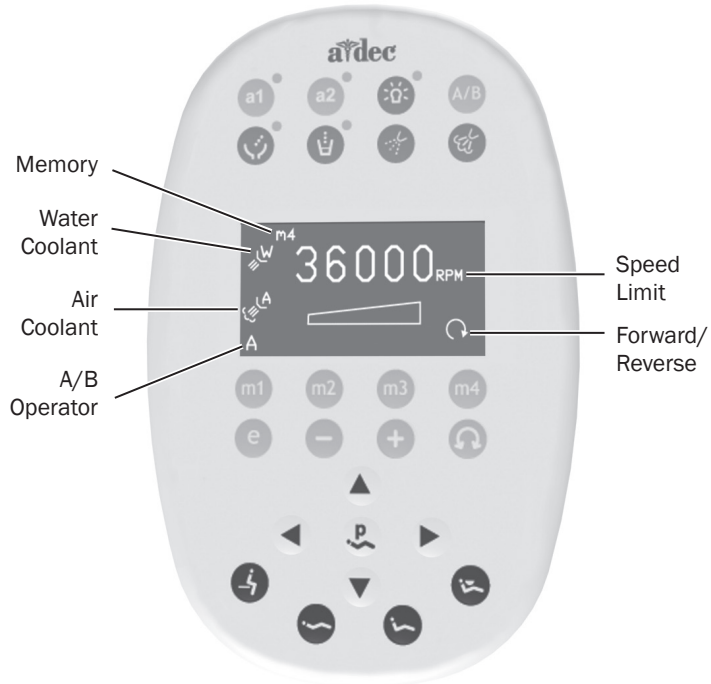

### Standard Mode Touchpad Screen Icons

Icon	Setting	Description
	Memory	Indicates the active memory setting.
	Water Coolant	When active, supplies water coolant to the handpiece.
	Air Coolant	When active, supplies air coolant to the handpiece.
	A/B Operator	Indicates the active operator set.
	Speed Limit	Setpoint for the speed limit. For more information, consult your file manufacturer.
	Forward/Reverse	Indicates the direction of the electric motor.

### Forward/Reverse Button *(standard and endo modes)*

The forward/reverse button (Ⓢ) changes the electric motor’s direction. The system defaults to the forward position when you return the motor to the holder or turn off the system. In reverse mode, the screen icon flashes continuously.



**NOTE** You can also use the foot control to easily switch between forward and reverse. When the motor has stopped, tap the accessory (chip/air) button to change the direction.



## Electric Handpiece Settings *(deluxe touchpad only) (continued)*

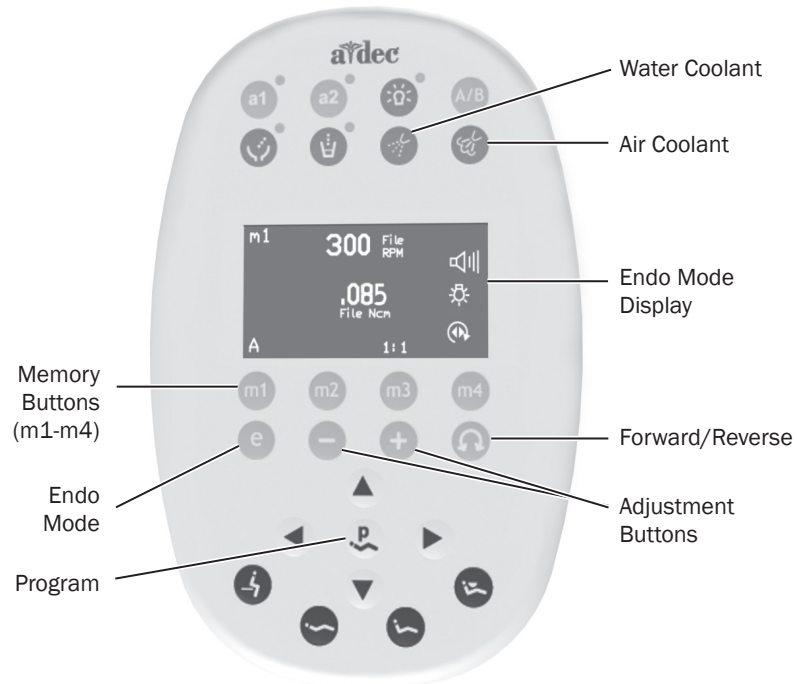

### Endodontics (Endo) Mode

In addition to handpiece speed adjustments, the endo mode allows you to change a number of settings based on the specific file and desired handpiece behavior. Icons on the touchpad screen reflect the settings.



**NOTE** For more information regarding speed and torque limits for a specific file, consult the file manufacturer.

To program the handpiece setting:

1. Lift the handpiece from the holder.
2. If the touchpad screen does not display the endo mode, press **e**.
3. To change settings in endo mode, press **+** or **-**. A white reverse video box is displayed on the touchpad screen.
4. Use the chair positioning buttons to move from setting to setting on the touchpad screen.
5. Use **+** or **-** to change the setting as desired.
6. To set the speed limit, torque limit, or ratio into memory, press **m**. One beep sounds.
7. Press m1, m2, m3, or m4 to choose the desired memory setting. Three beeps confirm the setting.







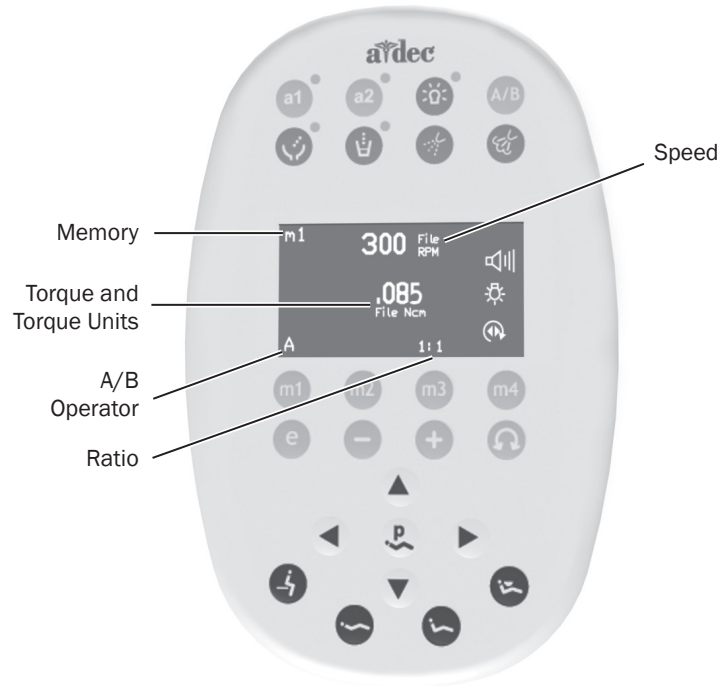



**NOTE** When a lever foot control is installed, the air and water coolant buttons do not function.

## Electric Handpiece Settings *(deluxe touchpad only) (continued)*







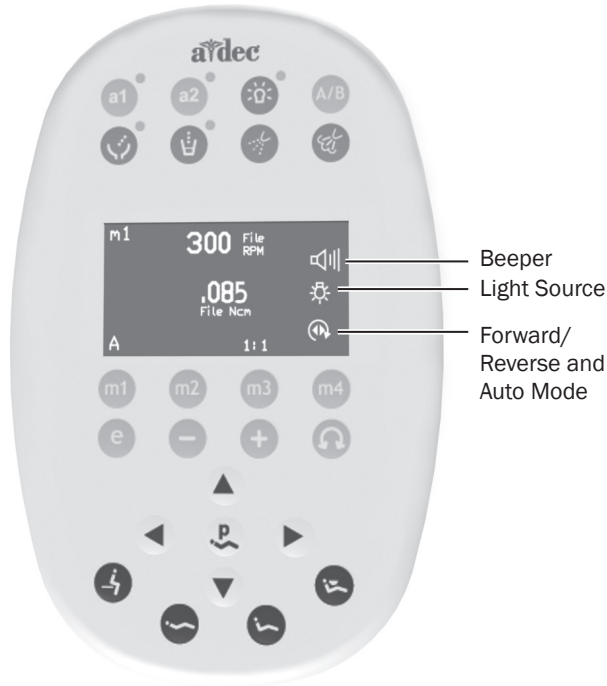

### Endo Mode Touchpad Screen Icons

Icon	Setting	Description
	Memory	Indicates the active memory setting.
	Torque	Setpoint for the file torque limit. For more information, consult your file manufacturer.
	Torque Units	Toggles between newton centimeters (N·cm) and gram centimeters (g·cm). Adjusting this setting for one handpiece changes it for all handpiece settings. <i>Note: 1 N·cm = 102 g·cm.</i>
	A/B Operator	Indicates the active operator set.
	Ratio	Indicates the handpiece ratio or handpiece model for A-dec W&H endo handpieces. For more information, consult your handpiece manufacturer.
	Air Coolant	When active, supplies air coolant to the handpiece.
	Water Coolant	When active, supplies water coolant to the handpiece.
	Speed	Setpoint for the file speed limit. For more information, consult your file manufacturer.

## Electric Handpiece Settings *(deluxe touchpad only) (continued)*



## Endo Mode Touchpad Screen Icons *(continued)*

Icon	Setting	Description
	Beeper	When active, the warning beep sounds when you approach torque limit and beeps twice when the file auto reverses. Adjusting this setting for one handpiece changes it for all handpiece settings.
	Light Source	Indicates if the light source is on in the endo mode.
	Auto Modes	Adjusting this setting for one handpiece changes it for all handpiece settings. The auto mode indicator displays inside of the forward/reverse indicator.
	Auto Stop	<ul style="list-style-type: none"> <li>When the file reaches the torque limit, the motor shuts off.</li> </ul>
	Auto Reverse	<ul style="list-style-type: none"> <li>When the file reaches the torque limit, the motor stops and reverses direction.</li> </ul>
	Auto Forward	<ul style="list-style-type: none"> <li>When the file reaches the torque limit, the motor stops, reverses 3 turns, and then changes back to forward again.</li> </ul> <p><i>Note: If the file is stuck, the auto forward cycle repeats three times before the motor stops.</i></p>

## Touchpad Help Messages



The deluxe touchpad screen displays help messages for disabled operations. When a help message appears, record the screen message and the function you were performing in case service is required. For more details on help messages, see the *Regulatory Information, Specifications, and Warranty* document (p/n 86.0221.00), which is available in the Document Library at [www.a-dec.com](http://www.a-dec.com).

## Auxiliary Control Buttons

Standard Touchpad



Auxiliary Buttons  
(when not used for  
cuspidor)

Deluxe Touchpad



If your system includes an A-dec relay module, you can use the touchpad to activate two auxiliary devices. On deluxe touchpads, use the a1 and a2 buttons to activate these devices. For systems with a standard touchpad, the bowl rinse and cupfill buttons serve as the auxiliary controls (not available on systems with a cuspidor).

## Other Handpiece and Accessory Settings

See your authorized A-dec dealer to change any of these handpiece and accessory settings, if applicable:

- **Auto-Off Delay** - determines how long the handpiece light remains on if the foot control is released. The default setting is 5 seconds.
- **On When Selected** - specifies whether the handpiece light turns on or remains off (until the foot control is pressed) when the handpiece is removed from the holder. The default setting is on.
- **On in Endo** - specifies whether the handpiece light turns on or off when the endo mode is selected. The default setting is off, which is recommended to reduce heat and extend bulb life.
- **Voltage Adjustment** - allows for customized light output voltage for each handpiece position. The default setting is 3.2 VDC.

## Handpiece Coolant Adjustments



**CAUTION** When performing this procedure, do not attempt to completely shut off the water or air flow. The adjustment knobs are not designed to completely shut off flow and can damage the control block if you apply too much force.

---

The air coolant knob on your delivery system simultaneously adjusts air flow to all handpiece positions. Each water coolant knob adjusts water flow to a single position.

Use the following process to adjust for the desired handpiece coolant atomization:

1. Insert a bur into each handpiece you are adjusting.
2. For systems with a deluxe touchpad and without a lever foot control, verify that the air and water coolant is on at the touchpad.
3. For systems with a deluxe touchpad, turn the air coolant off at the touchpad. For systems without a deluxe touchpad, turn the air coolant adjustment knob clockwise until coolant flow stops.

## Handpiece Coolant Adjustments *(continued)*

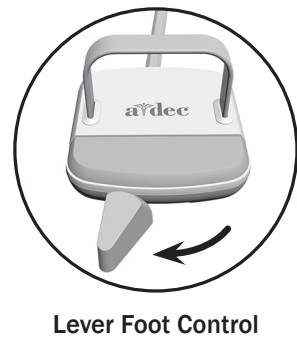
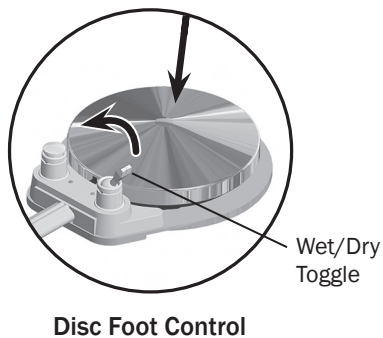
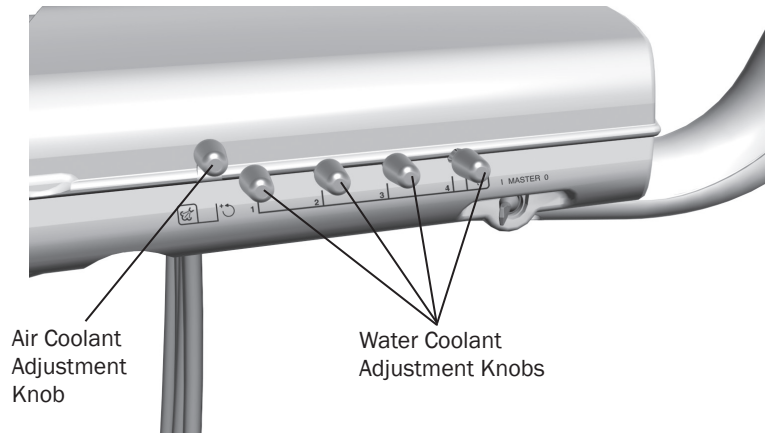

4. Lift the handpiece from the holder, or pull the whip forward, and do one of the following:
  - On a disc foot control: use the deluxe touchpad to turn the water coolant on, or flip the wet/dry toggle to water (toward the blue dot), and press the disc all the way down.



**NOTE** On systems with a deluxe touchpad, the toggle works as a three-way switch, and the blue dot does not indicate if the water is on or off. Only the touchpad display will indicate if the water is on or off.

- On a lever foot control: move the lever all the way to the left.
5. Locate the water coolant adjustment knob for the handpiece position you are adjusting and turn it clockwise until coolant flow stops.
6. Slowly turn the water coolant adjustment knob counterclockwise until water droplets are expelled from every water port on the handpiece head. Return the handpiece to the holder.
7. Repeat steps 3 through 5 for each handpiece.
8. To set the air coolant for the system, if the air coolant is off at the touchpad, turn it on, and then lift a handpiece from the holder or pull the whip forward.
9. Turn the air coolant adjustment knob counterclockwise to increase flow, or clockwise to decrease flow, until you achieve the desired atomization at the cutting surface of the bur.



**CAUTION** Do not continue turning the air coolant adjustment knob counterclockwise after the air coolant stops increasing. The stem may come out of the control block.

10. If you require more water coolant, increase the water output in step 6 as needed.

## Handpiece Drive Air Adjustments

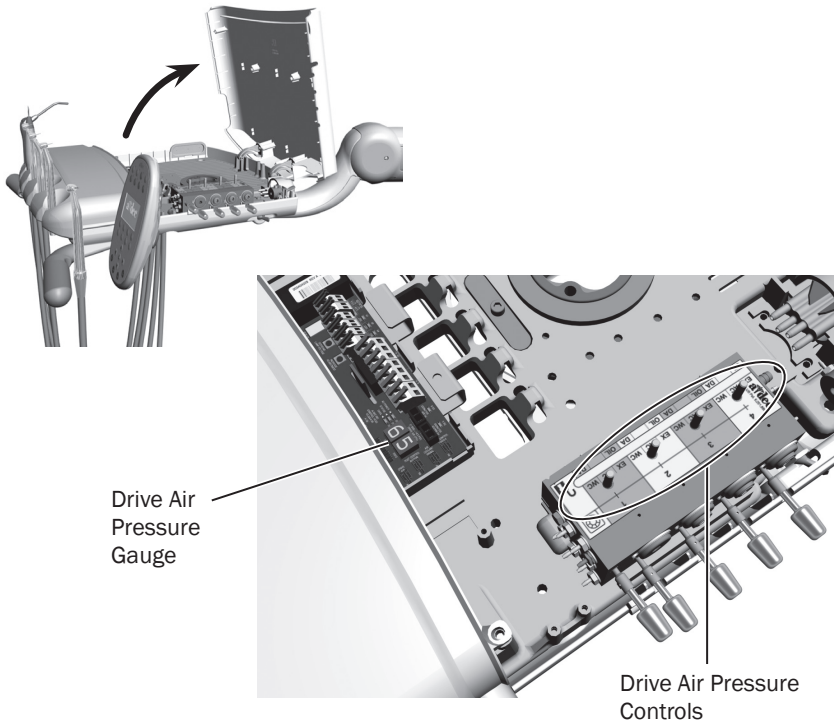

The drive air pressure controls adjust the pressure for each handpiece. The digital drive air pressure gauge is located inside the control head on the circuit board.

The gauge indicates, in psi, the drive air pressure (one bar equals 14.5 psi) to the active handpiece.



**NOTE** Use a handpiece pressure gauge attached to the handpiece tubing for exact drive air measurement.

To adjust the drive air pressure for each handpiece:

1. Locate the drive air pressure gauge and controls inside the control head.
2. Lift the handpiece from the holder or pull the whip forward.
3. Do one of the following:
  - On a disc foot control: use the deluxe touchpad to turn the water coolant off, or flip the wet/dry toggle to dry, and press the disc all the way down.
  - On a lever foot control: move the lever all the way to the right.
4. With the handpiece running, watch the gauge and adjust the handpiece drive air pressure to meet the manufacturer's specifications.
  - Turn the control to the right to decrease flow.
  - Turn the control to the left to increase flow.

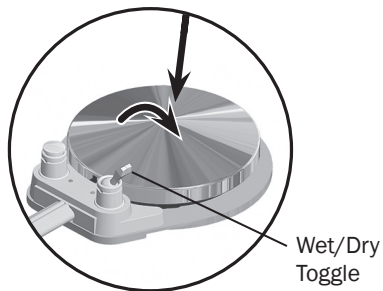

Disc Foot Control



Lever Foot Control



**CAUTION** See your handpiece documentation for the drive air pressure specification. Exceeding manufacturer's recommendations increases the risk of damage and may significantly decrease the life of your handpiece components.



## Rotational Adjustments

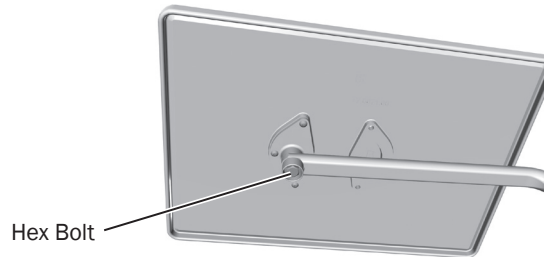
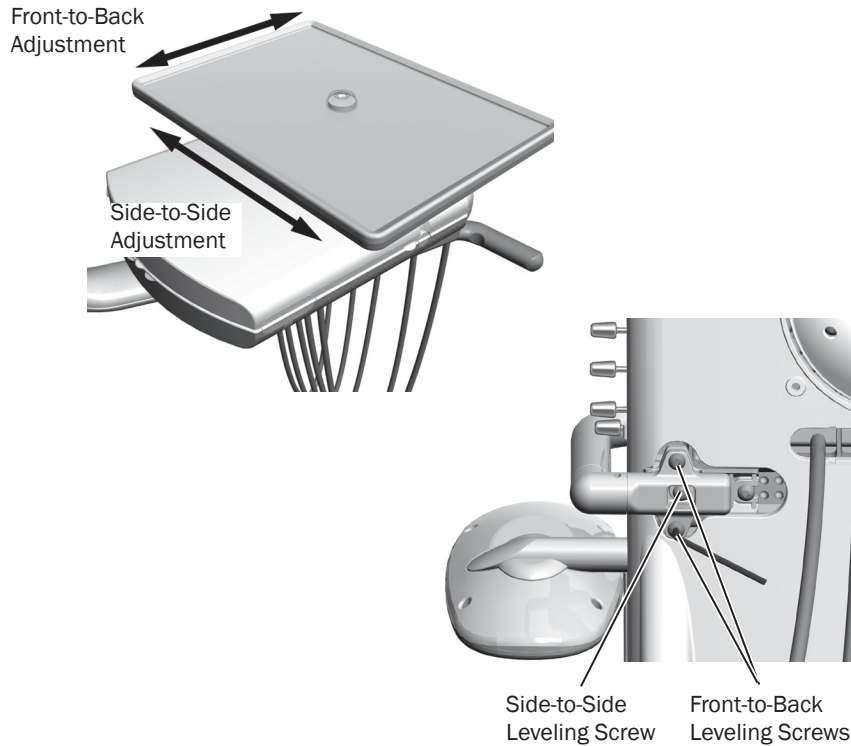

## Tray Holder

Tray holders for A-dec 500 delivery systems are adjustable side-to-side and front-to-back. The side-to-side and front-to-back adjustments are made independently.

1. Place a level on top of the tray.
2. Use the leveling screw to level the tray side-to-side.
3. Use the leveling screws to level the tray front-to-back.

## Tray Holder Tension

To tighten the rotational tension of the tray holder, turn the hex bolt under the tray clockwise. To loosen the rotational tension, turn it counterclockwise. To adjust the rotational tension of the tray arm, tighten or loosen the hex bolt at the delivery system end of the arm.

## Rotational Adjustments *(continued)*

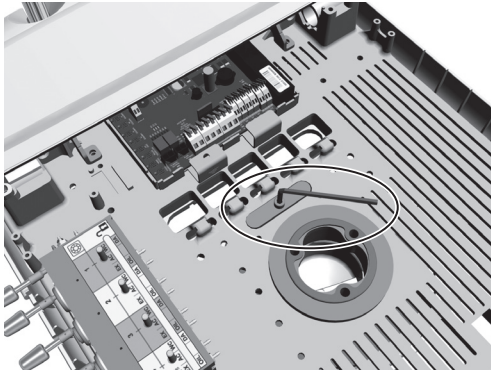

### Control Head

Adjust the control head rotation tension if the control head drifts to the left or right. Tighten or loosen the screw in the center of the control head platform to reach the desired tension.

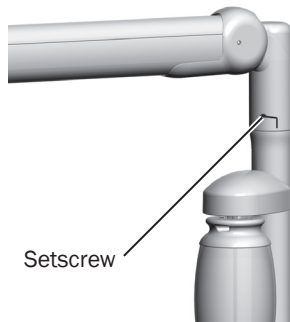

### Flexarm

If the control head drifts right or left on the mounting arm, adjust the flexarm rotation tension. To adjust the rotation tension:

- Turn the setscrew clockwise to tighten.
- Turn the setscrew counterclockwise to loosen.

## Handpiece Holders

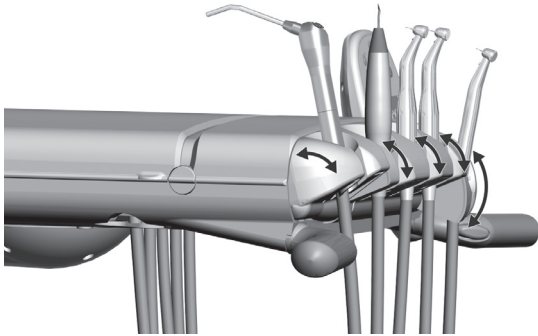

On Traditional delivery systems, you can adjust the outer holders independently from the three interior holders. To adjust, grasp the brake handle while pushing down or pulling up the holders until you achieve the desired angle.

## Front-Mount Tension

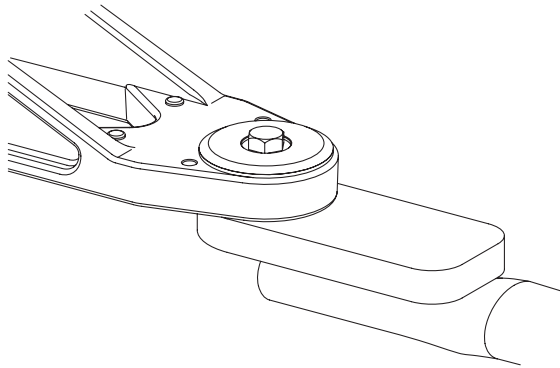

If the front-mount arm drifts on the A-dec 532/533 front-mount delivery systems, adjust the front-mount tension adjustment. To adjust the front-mount tension, tighten or loosen the bolt and nut located at the base of the front-mount arm.

## Flexarm Counterbalance *(A-dec 532/533 only)*

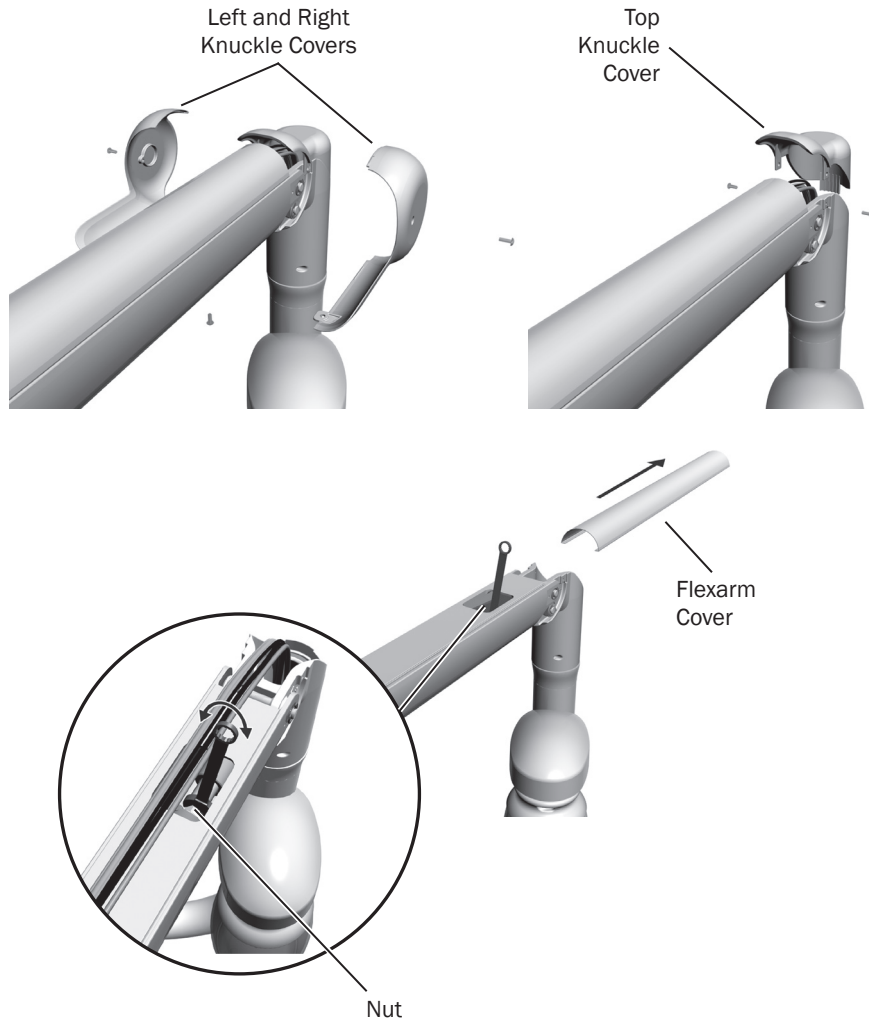

For A-dec 532/533 front-mount delivery systems, adjust the flexarm counterbalance if the control head drifts up or down.

1. Load the control head for normal use. Attach handpieces and place a tray with instruments on the tray holder.
2. Move the control head into position for treatment use.
3. Turn the master toggle off. Check whether the control head drifts up or down.
4. If the control head drifts, lower the control head and remove the knuckle covers from both ends of the flexarm. Remove the left and right side covers first, and then the top cover.
5. Slide the flexarm cover off the top of the flexarm.
6. Use a 7/16" wrench to adjust the spring tension:
  - Loosen the nut if the arm drifts up.
  - Tighten the nut if the arm drifts down.
7. Recheck the adjustment.

## Flexarm Counterbalance *(A-dec 542 only)*

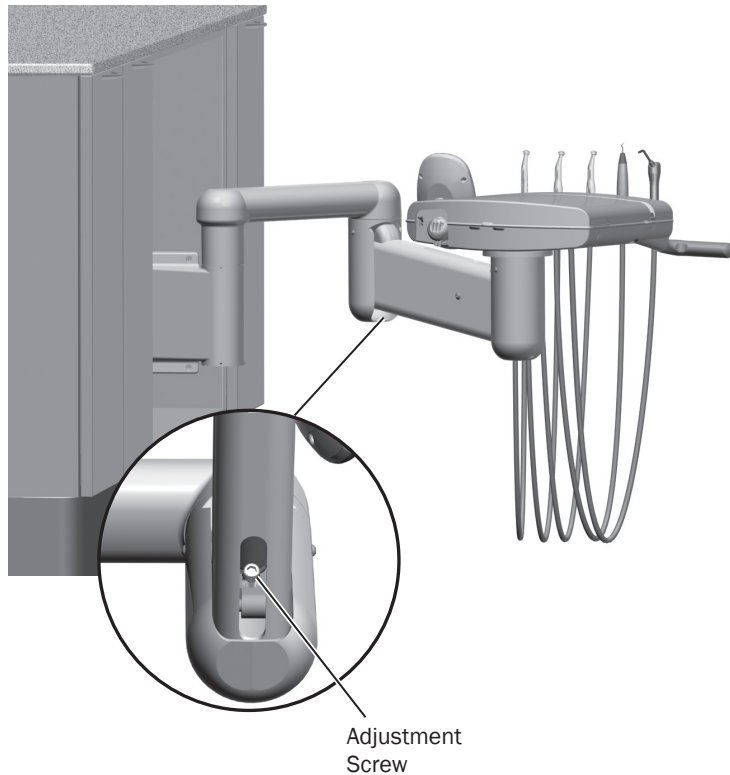

Adjust the flexarm counterbalance if the control head on the A-dec 542 side delivery system drifts up against the cabinet when the master switch is turned off.

1. Load the control head for normal use. Attach handpieces and place a tray with instruments on the tray holder.
2. Move the control head to the lowest position.
3. Turn the master toggle off. Check whether the control head drifts up against the cabinet.
4. Insert a hex key into the adjustment screw.
  - Turn the hex key clockwise to increase the upward drift.
  - Turn the hex key counterclockwise to reduce the upward drift.

# Clean / Maintain

## Barrier Protection

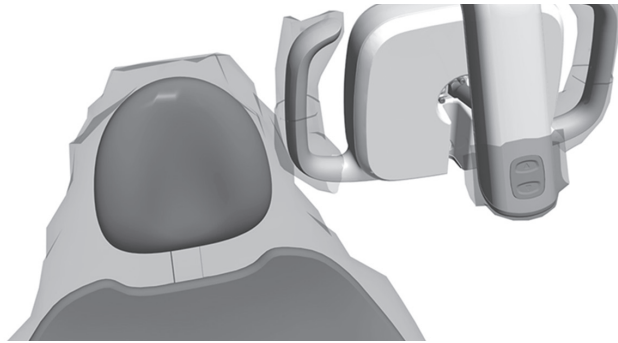

**NOTE** For proper use and disposal of barriers, see the instructions provided by the barrier manufacturer.

A-dec recommends barrier protection for all applicable touch and transfer surfaces. Touch surfaces are areas that come into contact with hands and become potential cross-contamination points during dental procedures. Transfer surfaces are areas that come into contact with instruments and other inanimate objects.

In the USA, barriers must be produced under the Current Good Manufacturing Practice (CGMP) as specified by the U.S. Food and Drug Administration (USFDA). For regions outside the USA, refer to the medical device regulations specific to your location.



**IMPORTANT** For recommendations on cleaning and chemical disinfection of touch and transfer surfaces (where barrier protection is not applicable or when barriers are compromised), please see the *A-dec Equipment Asepsis Guide* (p/n 85.0696.00).

## Waterline Maintenance



Self-Contained Water Bottle



A-dec recommends that you perform a shock treatment on the dental unit waterlines before you use the system for the first time.

For on-going waterline maintenance, A-dec recommends a three-part protocol: continuous use of A-dec ICX® waterline treatment tablets, regular dental unit water monitoring, and shock treatment.



**IMPORTANT** For complete details on how to maintain good water quality in your system, see the instructions for use provided with ICX and your self-contained water bottle:

- A-dec ICX* ..... p/n 86.0613.00
- A-dec Self-Contained Water System* ..... p/n 86.0609.00
- Waterline Maintenance Guide* ..... p/n 85.0983.00

## Handpiece Tubing

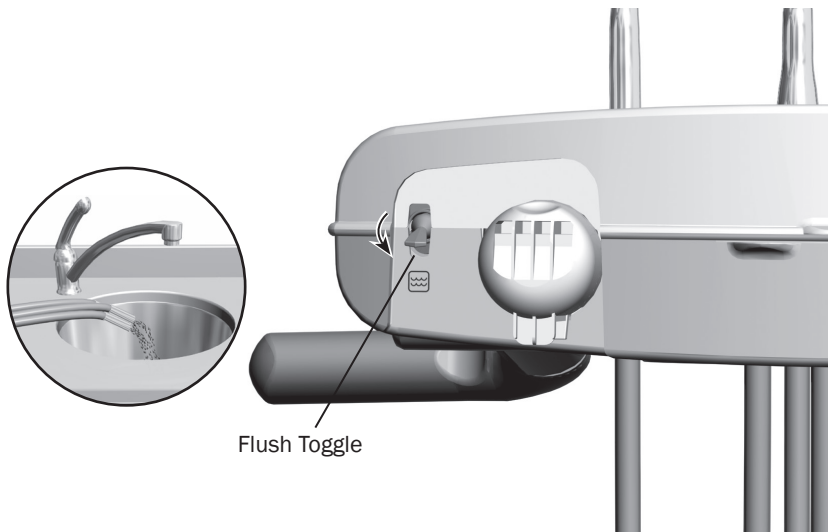

Use the flush toggle to move a high volume of water through the handpiece tubing. To flush the tubing:

1. Disconnect the handpieces.
2. Hold all of the handpiece tubing that uses water coolant over a sink, cuspidor bowl, or basin.
3. Hold the flush toggle down for 20–30 seconds.



**NOTE** Discharge all tubing air and water lines for 20–30 seconds after each patient.



**IMPORTANT** For recommendations on cleaning and chemical disinfection of touch and transfer surfaces (where barrier protection is not applicable or when barriers are compromised), please see the *A-dec Equipment Asepsis Guide* (p/n 85.0696.00).

## Oil Collector

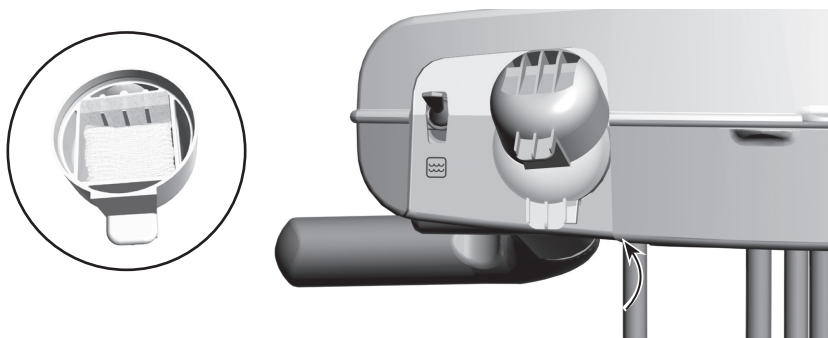

Service the oil collector on the delivery system once a week for normal usage and more often for heavier use. To service:

1. Unsnap the oil collector cover from the control head and discard the old gauze. Do not remove the foam muffler.
2. Fold a new gauze pad (2" x 2" [51 mm x 51 mm]) into quarters and place it inside the cover.
3. Snap the oil collector cover closed.



## Utilities and Shutoff Valves

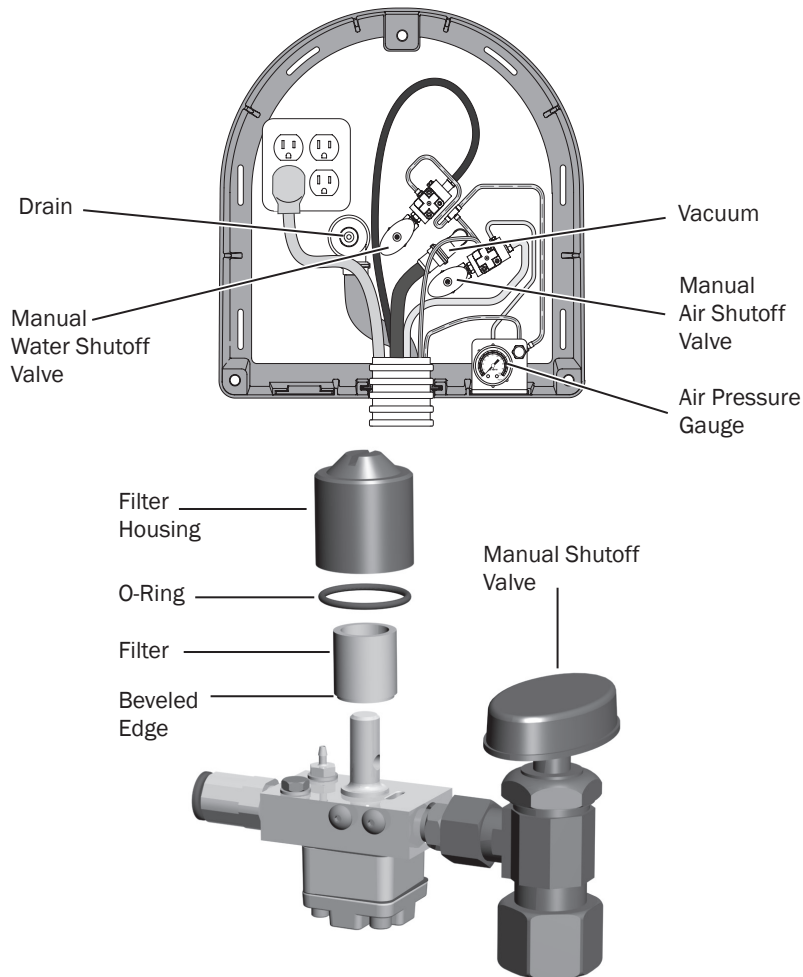

**CAUTION** To ensure proper operation, install the filter with the beveled edge facing the manifold.

The utilities are located in the contoured floor box for chair-mounted systems (A-dec 532/533) or in the cabinet for side delivery systems (A-dec 542). To access, lift up the floor box cover or removable cabinet panel.



**CAUTION** When removing or replacing covers, take care not to damage any wiring or tubing. Verify that the covers are secure after replacing them.

The manual shutoff valves control the air and water to the system. Leave these valves completely open (turned counterclockwise) during normal use to prevent leaks. From the valves, air and water pass through separate filters before entering the pre-regulators. Replace these filters when they become clogged and restrict flow.

To check for a clogged air or water filter:

1. Flip the master toggle to the on position.
2. While watching the air pressure gauge, press the syringe air button.
3. If the pressure drops by more than 15 psi, replace the air filter.
4. While watching the cuspidor, press the bowl rinse button. If the water flow fades or stops, replace the water filter.

To replace the filter:

1. Flip the master toggle to the off position and close the shutoff valve (turn clockwise).
2. Bleed the system of air and water pressure by operating the syringe buttons until air and water no longer flow.
3. Using a standard screwdriver, remove the filter housing from the water pre-regulator assembly and remove the filter.
4. Replace the filter if it is clogged or discolored. Install the filter with the beveled edge facing the manifold.
5. Open the shutoff valves, flip the master toggle to the on position, and operate the bowl rinse to remove air from the waterline.

## Utilities and Shutoff Valves *(continued)*

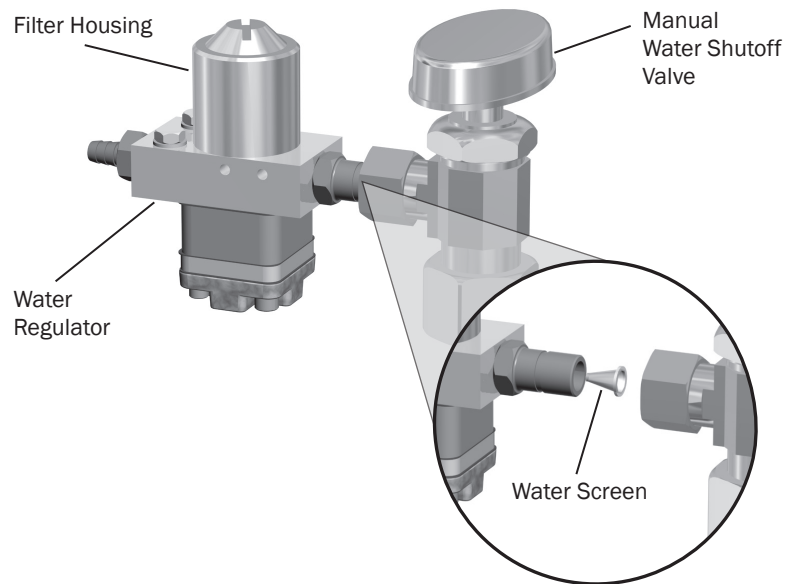

The manual water shutoff valves include a screen to prevent larger debris from entering the system. Periodically check and replace this screen to ensure unrestricted water flow.

To replace the water screen:

1. Flip the master toggle to the off position and close the shutoff valves (turn clockwise).
2. Use a 5/8" or adjustable wrench to loosen the compression nut on the manual water shutoff valve. Then pull the water regulator out of the shutoff valve.
3. Remove the old screen and replace with the new screen.
4. Reposition the water regulator in the manual shutoff valve outlet and tighten the compression nut.
5. Open the manual water shutoff valve (turn counterclockwise) and flip the master toggle to the on position.
6. Check the fittings for leaks.

## Bulb for Fiber-Optic Tubing

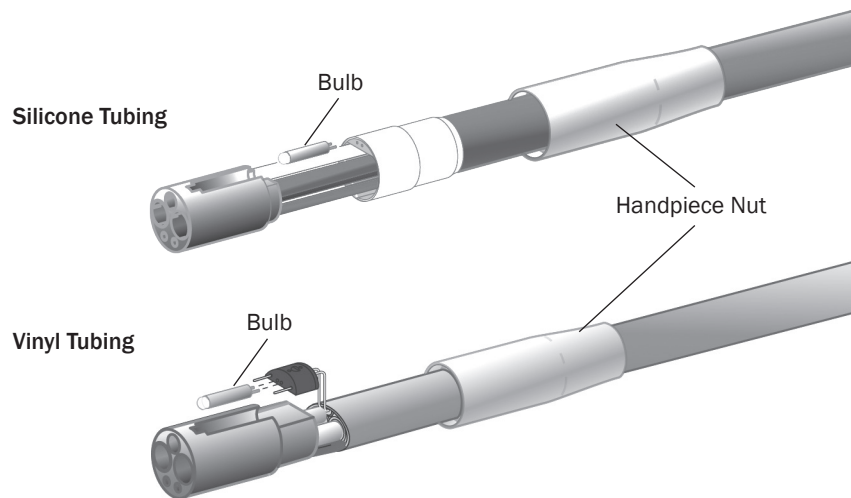

To replace the bulb in your fiber-optic 5-hole silicone or vinyl tubing:

1. Disconnect the handpiece and quick-connector coupling from the tubing.
2. Pull back the metal handpiece nut.
3. Slide back the metal portion of the handpiece terminal (silicone tubing only).
4. Replace the bulb.
5. Reinsert the metal portion of the terminal into the plastic portion (silicone tubing only).
6. Carefully slide the handpiece nut back over terminal.



**IMPORTANT** To replace the bulbs in your handpieces or quick-disconnect couplings, see the instructions that came with your handpieces.

# Specifications

---

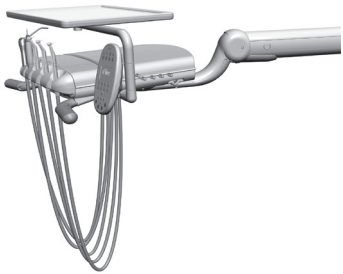

## Minimum Air, Water, and Vacuum Service Requirements

Air:	70.80 L/min (2.50 scfm) at 551 kPa (80 psi)
Water:	5.68 L/min (1.50 gpm) at 276 kPa (40 psi)
Vacuum:	
Wet:	212 L/min (9 scfm) at 27 kPa (8" of mercury)
Dry/Semidry:	340 L/min (12 scfm) at 12 kPa (3.5" of mercury)



**IMPORTANT** For chair accessory load capacity, electrical specifications, identification of symbols, and other regulatory requirements, see the *Regulatory Information, Specifications, and Warranty* document (p/n 86.0221.00), which is available in the Document Library at [www.a-dec.com](http://www.a-dec.com).



**NOTE** Specifications are subject to change without notice. Requirements may vary depending on your location. For more information, contact your authorized A-dec dealer.

---

# Warranty

---

Warranty information is provided in the *Regulatory Information, Specifications, and Warranty* document (p/n 86.0221.00), which is available in the Document Library at [www.a-dec.com](http://www.a-dec.com).







#### **A-dec Headquarters**

2601 Crestview Drive  
Newberg, Oregon 97132  
United States  
Tel: 1.800.547.1883 within USA/CAN  
Tel: +1.503.538.7478 outside USA/CAN  
Fax: 1.503.538.0276  
[www.a-dec.com](http://www.a-dec.com)

#### **A-dec Australia**

Unit 8  
5-9 Ricketty Street  
Mascot, NSW 2020  
Australia  
Tel: 1.800.225.010 within AUS  
Tel: +61.(0).2.8332.4000 outside AUS

#### **A-dec China**

A-dec (Hangzhou) Dental Equipment Co., Ltd.  
528 Shunfeng Road  
Qianjiang Economic Development Zone  
Hangzhou 311106  
Zhejiang, China  
Tel: +1.503.538.7478

#### **A-dec United Kingdom**

*EU Authorized Representative*  
Austin House, 11 Liberty Way  
Nuneaton, Warwickshire CV11 6RZ  
England  
Tel: 0800.ADEC.UK (2332.85) within UK  
Tel: +44.(0).24.7635.0901 outside UK

CE  
0843



86.0607.00 Rev J  
Copyright 2016 A-dec Inc.  
All rights reserved.